



For your reference:

Please note that this product is no longer available and is provided as a reference technical document.

FREQUENCY RESPONSE ANALYZER

FRA5097

INSTRUCTION MANUAL



DA00014283-004

FREQUENCY RESPONSE ANALYZER

FRA5097

INSTRUCTION MANUAL

Preface

Thank you for purchasing “FRA5097 Frequency Response Analyzer”.
Please read, first of all, “Safety Instructions: To safely use the frequency response analyzer” on the next page, so that you can use the instrument in the correct and safe manner.

- Notes on marks, symbols and terminology used in this Manual
The marks shown below are used in this Manual to indicate Warning and Caution instructions. Please carefully follow the instructions that are indicated by these marks, so that users or operators are safe in using the instrument and that the instrument will not be damaged during operation.



Instructions are given to avoid such potential hazardous situations that instrument operators would be involved in a risk of facing death and/or personal injury due to an electric shock or other reasons.



Instructions are given to avoid possible instrument damages due to incorrect use/operation of the instrument.

- This Instruction Manual comprises the following Chapters.
Please read the Manual from the very beginning, i.e., from Chapter 1, if you use this type of instrument for the first time. Meanwhile, please advised that the instructions for the GPIB interface are included in a separate manual.

1. Introduction

This Chapter involves such information as overview, features, applications, functions and operational principles of the instrument.

2. Preparations before using the instrument

Information is given in this Chapter on what should be done by users and other people concerned before you use the instrument. The information includes installation of the instrument.

3. Panels; indications and operations

Descriptions are provided in this Chapter on displays and basic operations of the instrument as well as on keys, indications and other parts located on panels.

Please also read this Chapter while you operate the instrument.

4. Examples of applications

Wider ranges of operational procedures are described in this Chapter for some applications.

5. Impedance display function

Operation of the impedance display function is described.

6. Files

Descriptions are given for file formats of USB flash drive.

7. Trouble-shooting

Error messages and their implications are described.

8. Maintenance

Procedures of performance testing of the instrument are described. Information on storage, re-packaging and transportation is also provided.

9. Specifications

Instrument specifications are provided in regard to functions and performance.

———— **Safety Instructions: To safely use the frequency response analyzer** ————

The following instructions, including all Warnings and Cautions, shall be observed by all means to protect yourself as well as public safety.

Please be advised that NF Corporation shall not be responsible for, and warranty shall be waived for, any loss or damages that will have resulted from ignorance or omissions of these instructions, Warnings or Cautions.

This instrument is compliant with the insulation Class I (with protective conductor terminals) of the JIS and IEC Standards.

● **Observe all the instructions of this Instruction Manual by all means.**

This Instruction Manual contains those instructions which are to be observed by users so that users and/or operators prepare and operate the instrument in safety.

Read the Manual by all means as your first duty before you use the instrument.

All the Warnings described in this Manual are provided for you to avoid any serious accidents to occur from using the instrument. Therefore, your observation of the instructions in the Manual is essential to use the instrument.

● **Ground the instrument at all times.**

Line filters are used for this instrument, and therefore, you will have a risk of an electric shock unless the instrument is properly grounded.

To avoid risk of electric shock, be sure to connect securely to ground through less than 100Ω.

This instrument is so designed that the instrument will be grounded by connecting its three-pole power supply plug with a three-pole electric power source outlet with a proper grounding connection.

● **Inspect and confirm the electric power source voltage.**

This instrument operates at the power source voltage as described in Section 2.3 “Grounding and Power Supply Connection” in this Manual.

Inspect and confirm that the outlet voltage conforms to the rated voltage of the instrument, before connecting the power supply of the instrument to the power source.

● **React promptly if you notice anything wrong with the instrument.**

Promptly stop operating the instrument by disconnecting the power supply cable plug from the power source outlet, if any amount of smoke or strange smell or sound comes out of the instrument, for example.

If such an abnormal occurs, prevent anyone from using this instrument until it has been repaired, and immediately report the problem to NF Corporation or one of our representatives.

● **Do not operate the instrument in the gaseous environment.**

Operation of the instrument in any gaseous environment could cause an explosion.

● **Do not remove the housing (cover) from the instrument.**

High voltages appear inside of the instrument. Do not remove the housing (cover) from the instrument by any means.

No one except the service technicians certified by NF Corporation are allowed to check or touch the inside of this instrument. Do not touch the inside by yourself in any case.

● **Do not modify the instrument.**

Never modify or try to modify the instrument. Your modification of the instrument could cause unexpected accidents or failures. NF Corporation has the right to refuse providing services for any instruments modified by unauthorized persons.

● **Do not expose this product to water.**

When this product is used in wet condition, it may cause an electric shock and a fire. If this product is exposed to water. Unplug the mains supply cord immediately, and contact NF Corporation or one of our representatives.

● **If lightning occurs, power off this product and unplug the mains supply cord.**

A lightning may cause an electric shock, a fire and a failure.

● **Marks and codes to indicate safety information and/or instructions:**

General definitions for marks and codes to indicate safety information and/or instructions in this Manual as well as at the instrument itself are the following:



Instructions Manual reference mark

This mark indicates that users should pay attention to potential failures, damages or injury and that they are requested to refer to the appropriate section in the Reference Manual.



Mark to indicate risks of electric shocks

This mark is used at locations where one can receive an electric shock under certain conditions.



Protective grounding terminal mark

This mark is used at the terminals that are required to ground to protect users against potential electric shocks.

Before operating the equipment, be sure to connect this terminal to ground through less than 100Ω. (The instrument will be grounded by connecting its three-pole power supply plug with a three-pole electric power source outlet with a proper grounding connection. When this connection is made, no grounding is required for the indicated terminal.)



Warning mark

Instructions are given to avoid such potential hazardous situations that instrument operators would be involved in a risk of facing death and/or personal injury due to an electric shock or other reasons.



CAUTION

Caution mark

Instructions are given to avoid possible instrument damages due to incorrect use/operation of the instrument.

● **Other marks and codes**



This mark indicates the “ON” position of the power supply switch.



This mark indicates the “OFF” position of the power supply switch.

- ⏏ This mark indicates that the outer conductor of the connector is connected with the instrument housing.
- ⏏ This mark indicates that the outer conductor of the connector is connected with the signal ground

● Cautions for disposal

For environmental protection, please note the following guidelines for disposal of this device.

1. This device is equipped with a lithium battery. Ask an industrial waste disposal contractor to dispose of such batteries.
2. The LCD backlight module contains mercury. Ask an industrial waste disposal contractor to dispose of the module.
3. Ask an industrial waste disposal contractor to dispose of the entire device.

Contents

Preface.....	I
Safety Instructions: To safely use the frequency response analyzer	II
1. Introduction	1-1
1.1 Features	1-2
1.2 Applications.....	1-3
1.3 List of functions	1-4
1.4 Principle of operation	1-9
1.4.1 Basic principle	1-9
1.4.2 Block diagram.....	1-11
2. Preparations before use.....	2-1
2.1 Inspection before use.....	2-2
2.2 Mounting and installation.....	2-3
2.2.1 Location of installation	2-3
2.2.2 Criteria for location of installation.....	2-3
2.2.3 Rack mounting.....	2-4
2.3 Grounding and power supply connection	2-8
2.4 Compliant standards	2-9
2.5 Quick function checking	2-10
2.5.1 Checking functions and indications at power “ON”	2-10
2.5.2 Checking responses for key actions.....	2-10
2.6 Calibration.....	2-11
3. Descriptions on Panels and basic Operations.....	3-1
3.1 Panel descriptions	3-2
3.1.1 Front panel	3-2
3.1.2 Rear panel	3-9
3.1.3 Top panel	3-9
3.2 Display at power “ON” and initial settings	3-10
3.2.1 Displays and indications at power “ON”	3-10
3.2.2 Initialization.....	3-12
3.2.3 Warm-up	3-15
3.3 Input and output terminals.....	3-16

Contents

3.4	Insulation breakdown voltages of input and output voltages.....	3-19
3.5	Examples of basic operations	3-21
3.5.1	Menu operation.....	3-21
3.5.2	On/off operations for oscillator output.....	3-25
3.5.3	Examples of basic measurement operations.....	3-26
3.5.4	Examples of connections	3-30
3.5.5	High frequency measurement.....	3-33
4	Examples of application operations	4-1
4.1	Overview of measurement and processing	4-2
4.1.1	Measurement mode.....	4-3
4.1.2	Analysis mode	4-4
4.1.3	Graph units setting.....	4-4
4.1.4	Display mode	4-5
4.2	Delaying measurement start.....	4-7
4.3	Integration.....	4-8
4.4	Input setting.....	4-10
4.5	Oscillator setting	4-11
4.5.1	Oscillator basic setting.....	4-11
4.6	Display setting.....	4-15
4.6.1	Setting display format.....	4-15
4.6.2	Setting display scale.....	4-16
4.6.3	Setting grids.....	4-16
4.6.4	Setting markers	4-18
4.6.5	Setting phase display range	4-21
4.6.6	Selecting display data.....	4-21
4.7	Equalization	4-23
4.7.1	Operation of equalization	4-23
4.7.2	Principle of equalization	4-24
4.8	Harmonics analysis	4-25
4.9	Amplitude compression	4-26
4.10	Frequency axis high density slow sweep	4-29
4.11	Calculation functions.....	4-30
4.11.1	Operation of four rules of arithmetic.....	4-30
4.11.2	Differentiation and integration	4-31
4.11.3	Conversion between open and closed loops	4-32
4.12	Auto-sequence	4-34

Contents

4.12.1	Recording/storage of key sequence	4-34
4.12.2	Executing key sequence.....	4-35
4.12.3	Deleting key sequence.....	4-36
4.12.4	Other remarks on auto-sequence.....	4-36
4.13	Simplified load/save of setting conditions.....	4-37
4.13.1	Simplified condition load.....	4-37
4.13.2	Simplified condition save.....	4-38
4.14	Output to printer.....	4-39
4.14.1	Mounting printing paper	4-39
4.14.2	LCD screen hardcopy	4-41
4.15	Output to USB flash drive	4-42
4.15.1	LCD screen hardcopy	4-42
4.16	Calibration.....	4-43
4.17	File operation.....	4-44
4.18	Memory.....	4-47
4.19	Condition display	4-48
4.20	Max/min search function.....	4-48
4.21	Other functions	4-49
5.	Impedance display function	5-1
5.1	Overview	5-2
5.1.1	Impedance display	5-2
5.1.2	Open and short correction	5-2
5.2	Operation method	5-3
5.2.1	Impedance display description.....	5-3
5.2.2	Shunt resistance current-voltage conversion coefficient setting.....	5-6
5.2.3	Connection for impedance measurement	5-7
5.3	Open and short correction.....	5-8
5.3.1	Connection for open and short correction data storage	5-8
5.3.2	Data measurement and storage.....	5-8
5.3.3	Open and short correction data memory.....	5-10
5.3.4	Open and short correction function setting.....	5-10
6.	Files	6-1
6.1	Overview	6-2
6.2	Computer system in which you can read.....	6-2
6.3	File format	6-2

Contents

6.3.1	Format of measurement data files.....	6-4
6.3.2	Format of measurement conditions files.....	6-7
6.4	Software for reading files.....	6-13
6.4.1	Installation.....	6-14
6.4.2	Uninstallation.....	6-14
6.4.3	Overview of operations.....	6-15
7.	Trouble shooting.....	7-1
7.1	Error messages.....	7-2
7.1.1	List of information messages.....	7-2
7.1.2	List of error messages.....	7-3
7.2	Quick diagnosis.....	7-7
8.	Maintenance.....	8-1
8.1	Introduction.....	8-2
8.2	Daily maintenance.....	8-2
8.3	Storage, re-packaging and transportation.....	8-3
8.4	Identification of version number.....	8-3
8.5	Performance test.....	8-4
8.5.1	Test equipment.....	8-4
8.5.2	Pretest preparations.....	8-4
8.5.3	Oscillator output frequency accuracy.....	8-5
8.5.4	Oscillator output amplitude accuracy.....	8-6
8.5.5	Oscillator distortion.....	8-7
8.5.6	Oscillator output DC bias accuracy.....	8-8
8.5.7	Analyzer IMRR.....	8-9
8.5.8	Analyzer dynamic range.....	8-10
8.5.9	Analyzer measuring error frequency response.....	8-11
9.	Specifications.....	9-1
9.1	Oscillation section.....	9-2
9.2	Analysis section input.....	9-4
9.3	Measurement process.....	9-8
9.4	Analysis process.....	9-11
9.5	Calculations.....	9-11
9.6	Auto sequence.....	9-11
9.7	Display.....	9-12

Contents

9.8	Memory.....	9-13
9.9	External memory	9-13
9.10	Peripheral input/output functions	9-14
9.11	Impedance display function.....	9-15
9.12	Miscellaneous specifications	9-16

Warranty

Figures

Fig. 1-1	Measurement of frequency transfer characteristics with FRA.....	1-9
Fig. 1-2	Frequency sweep measurement with FRA	1-10
Fig. 1-3	FRA block diagram	1-11
Fig. 2-1	Size and dimensions of FRA5097 rack mount.....	2-5
Fig. 2-2	Mounting rack-mount adapter	2-6
Fig. 2-3	Removal of foot-stands	2-7
Fig. 3-1	From-enclosure isolation voltage specifications (when accompanying BNC cable is used).....	3-19
Fig. 3-2	From-enclosure isolation voltage specifications (when a cable other than the accompanying cable is used).....	3-19
Fig. 3-3	Oscillation section-analysis section inputs isolation voltage specifications (when accompanying BNC cable is used).....	3-20
Fig. 3-4	Oscillation section-analysis section inputs isolation voltage specifications (when a cable other than the accompanying cable is used).....	3-20
Fig. 3-5	Screen directly after start.....	3-21
Fig. 3-6	Top menu	3-22
Fig. 3-7	Menu window.....	3-23
Fig. 3-8	TABLE displays	3-23
Fig. 3-9	Display during entering figures.....	3-24
Fig. 3-10	Function Display	3-24
Fig. 3-11	Oscillator control key	3-25
Fig. 3-12	Connection with SUT.....	3-26
Fig. 3-13	SINGLE measurement result	3-27
Fig. 3-14	Connection diagram for frequency characteristics measurement (1)	3-30
Fig. 3-15	Connection diagram for frequency characteristics measurement (2)	3-30
Fig. 3-16	Connection diagram for loop gain measurement	3-31
Fig. 3-17	Connection diagram for impedance measurement.....	3-32
Fig. 4-1	Flow diagram of measurement and processing	4-2
Fig. 4-2	Measurement mode and internal connection	4-3
Fig. 4-3	Recommended measurement connection for two-port system	4-3
Fig. 4-4	Response waveform requiring measurement start time delay.....	4-7
Fig. 4-5	Effect of integration	4-9
Fig. 4-6	Principle of excessive level detection	4-10
Fig. 4-7	Oscillator stop mode	4-12

Figures

Fig. 4-8	Oscillator output voltage variation in the SLOW status	4-13
Fig. 4-9	Change of Stop mode during SLOW OFF	4-13
Fig. 4-10	Data marker display	4-19
Fig. 4-11	Examples of data display	4-19
Fig. 4-12	Line marker display	4-20
Fig. 4-13	Measurement/DUT system	4-23
Fig. 4-14	Principle of equalization.....	4-24
Fig. 4-15	Amplitude compression	4-26
Fig. 4-16	Principle of amplitude compression.....	4-26
Fig. 4-17	Example of output correction (70%)	4-27
Fig. 4-18	Functions/operations of four rules of arithmetic	4-30
Fig. 4-19	Differentiation and integration functions	4-31
Fig. 4-20	Open-loop and close-loop transfer functions.....	4-32
Fig. 4-21	Open the cover	4-39
Fig. 4-22	Load printer paper	4-39
Fig. 4-23	Loading printing paper	4-40
Fig. 4-24	Cover attachment.....	4-40
Fig. 4-25	Max/min search function keys.....	4-48
Fig. 5-1	Phase invert connection	5-6
Fig. 5-2	Impedance measurement connection	5-7
Fig. 5-3	Open correction example.....	5-8
Fig. 5-4	Short correction example.....	5-8
Fig. 5-5	Open and short correction function keys	5-8
Fig. 6-1	Structure of measurement data file.....	6-4
Fig. 6-2	Structure of measurement condition file.....	6-7
Fig. 6-3	Example of graph display by DSPL5090	6-13
Fig. 9-1	From-enclosure isolation voltage specifications (when accompanying BNC cable is used).....	9-5
Fig. 9-2	From-enclosure isolation voltage specifications (when a cable other than the accompanying cable is used).....	9-5
Fig. 9-3	Oscillation section input - analysis section input isolation voltage specifications (when accompanying BNC cable is used).....	9-5
Fig. 9-4	Oscillation section input - analysis section input isolation voltage specifications (when a cable other than the accompanying cable is used).....	9-7
Fig. 9-5	Block diagram	9-18
Fig. 9-6	External dimensions diagram.....	9-19

Tables

Table 2-1	Accessories	2-2
Table 3-1	List of initialization values	3-12
Table 4-1	List of analysis modes.....	4-4
Table 4-2	Display units	4-4
Table 4-3	List of display modes.....	4-5
Table 4-4	Graph axis contents.....	4-6
Table 4-5	Display mode that allows [X-Y1-Y2] grid display.....	4-16
Table 4-6	Active line markers	4-19
Table 4-7	Amplitude compression setting items.....	4-27
Table 4-8	High density slow sweep.....	4-29
Table 5-1	Graph axis contents.....	5-4
Table 5-2	Display mode list (1) Analysis mode: (CH1) or (CH2)	5-5
Table 6-1	Data types of variables within file	6-3
Table 6-2 a)	Measurement data file format - Header	6-4
Table 6-2 b)	Measurement data file format - Set parameters	6-5
Table 6-2 c)	Measurement data file format - Data (RAW data).....	6-6
Table 6-2 d)	Measurement data file format - Data (OPERATED data).....	6-6
Table 6-3 a)	Data format (RAW measurement data, RAW).....	6-6
Table 6-3 b)	Data format (OPERATED measurement data, OPRD)	6-6
Table 6-4 a)	Measurement condition file format - Header	6-7
Table 6-4 b)	Measurement condition file format - Condition data	6-8

1. Introduction

1.1	Features	1-2
1.2	Applications	1-3
1.3	List of functions	1-4
1.4	Principle of operation	1-9
1.4.1	Basic principle	1-9
1.4.2	Block diagram	1-11

1.1 Features

The “FRA5097 Frequency Response Analyzer” is a type of frequency response analyzers that feeds swept frequency signals to a system under test.

The “FRA5097 Frequency Response Analyzer” comprises a sweep oscillator subsystem with a frequency synthesizer incorporated that generates signals to be fed into the system under test, an analyzer subsystem that measures responses of the system under test for swept frequency signals, operates outcomes of Fourier integrals and calculates amplitudes and phases of the response signals, and a recorder/display subsystem that records and displays the measurement results.

a) High precision, wide dynamic range

The built-in oscillator uses a synthesizer system to maintain high frequency accuracy and resolution. By using a high-resolution A/D converter as well as an auto-ranging operation, the analysis section allocates an increasingly wider dynamic range and, furthermore, Fourier integrals and a self-calibration feature enable consistently high-precision measurements.

b) Insulated I/O terminal

The two analysis inputs and the oscillator output are independently isolated from the enclosure.

c) Wide band between 0.1 mHz and 15 MHz

The entire range between 0.1 mHz and 15 MHz can be swept and measured all at once.

d) Color TFT-LCD included

The built-in color TFT-LCD displays the frequency characteristic graphs and measurement condition setup menus.

e) USB flash drive supported (USB host connector located on front panel)

You can use USB flash drive (attached) to store the setting and measurement data. (The behavior of non-attached USB flash drive is not guaranteed). The file format is compatible with Windows 98 SE or later on IBM PC/AT compatible machines, which means IBM PC/AT compatible machines with a USB port can read/write the applicable files.

f) Setting and measurement data battery backup

The present setting values and measurement data stored in an involatile memory will be retained even after shutting down the power.

g) GPIB/USB as standard equipment

You can set the measurement conditions and read measurement data while using an external PC.

h) Thermal printer included

A thermosensitive printer that enables hardcopy outputs of the LCD screen is built in. This printer is useful for saving the measurement data and preparing reports.

i) Impedance display available

By combining FRA5097 with an amplifier or a shunt resistor, impedances can be measured in a wide range of voltages and amperes that normal LCR meters cannot cover. In addition, use of the impedance display feature facilitates accurate measurement and displaying of the impedances.

1.2 Applications

Since the FRA5097 Frequency Response Analyzer has such features as highly isolated input/output terminals, wide dynamic measurement range and high measurement accuracy, it can be used for various applications as described below. It can also be used to easily form an automatic measurement system combined with an on-line computer due to its standard availability or the GPIB capability.

- Servo-system Servo-loop characteristics measurement for DVD players, VTRs, etc.
- Electronic circuits Frequency characteristics measurement for filters, amplifiers, etc.
- Acoustic system Frequency characteristics measurement for speakers, microphones, etc.
- Vibration/oscillation analysis Resonance characteristics measurement
- Electrochemical area Studies on metal corrosion, battery performance measurement, etc.
(electrochemical impedance measurement)

1.3 List of functions

The following shows a list of important functions of the instrument. Thereunder, the function tree of instrument functions is illustrated.

Functions		general descriptions
Oscillator subsystem	OSC	Setting parameters of built-in oscillator such as frequency and amplitude
Analyzer subsystem input	Input	Setting analyzer input parameters such as excessive level detection threshold
Measurement control	Measure	Setting sweeping parameters, number of integration times, etc.
Graphic display control	Graph	Setting graphic display format, etc.
Calculation	Calc	Calculation of measurement data
Memory	Memory	Storing measurement data into internal memory, etc.
Output control	Output	Functions related to GPIB and printed output
Disk	Disk	Functions related to USB flash drive
Calibration	Calib.	Automatic calibration capabilities
Automatic sequencing	Autoseq	Automatic process execution in sequence
Others	Others	Setting time, etc.

Oscillator subsystem

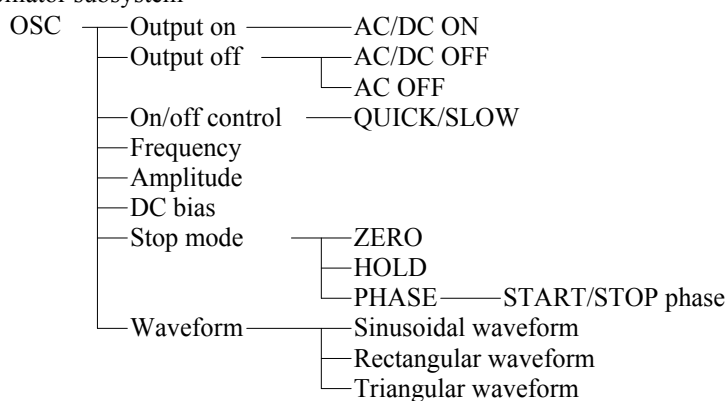

Analyzer subsystem input

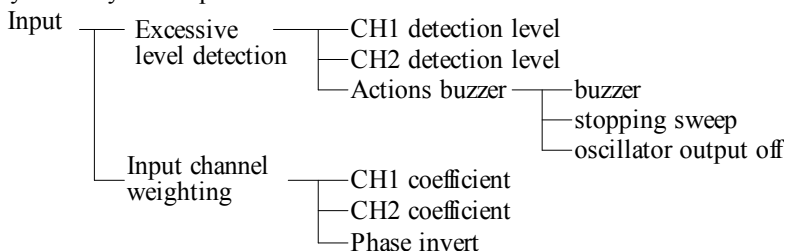

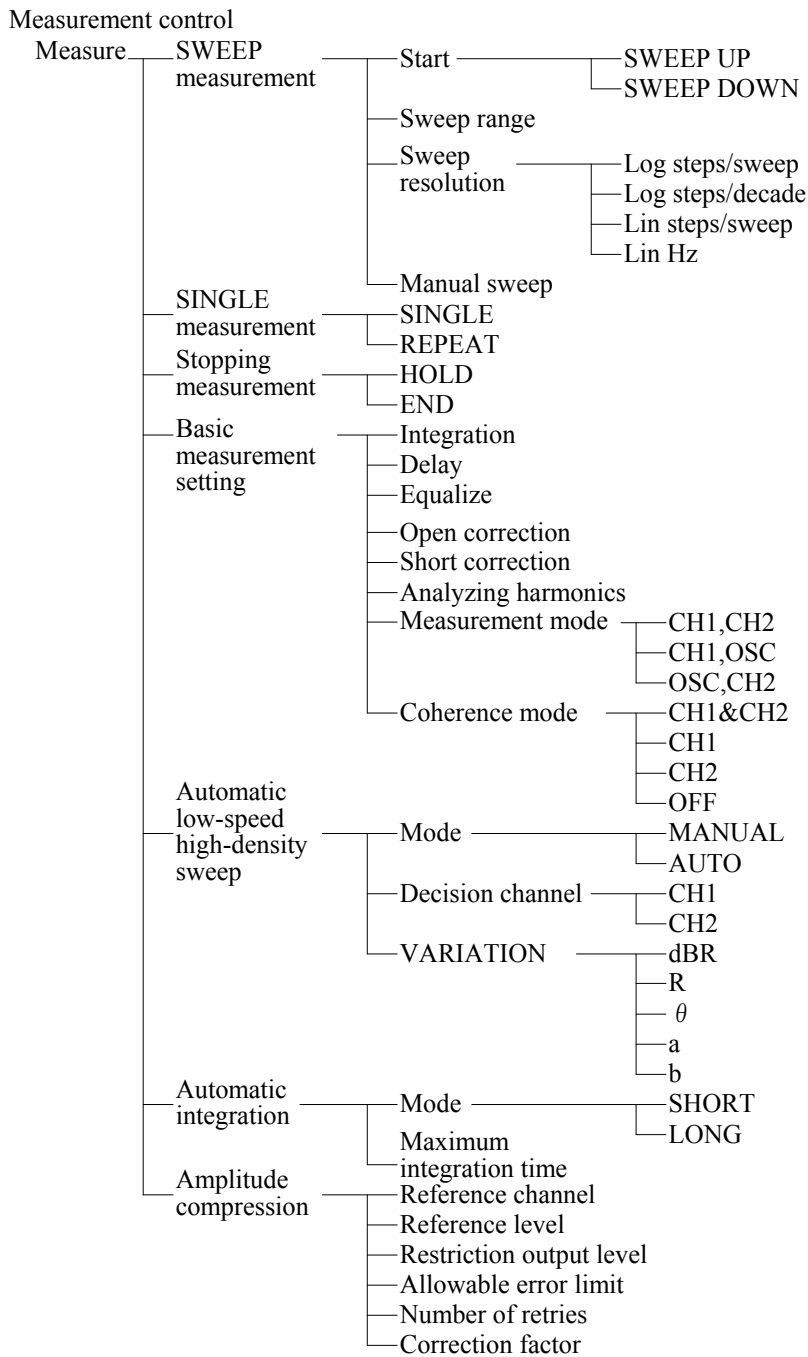

1.3 List of functions

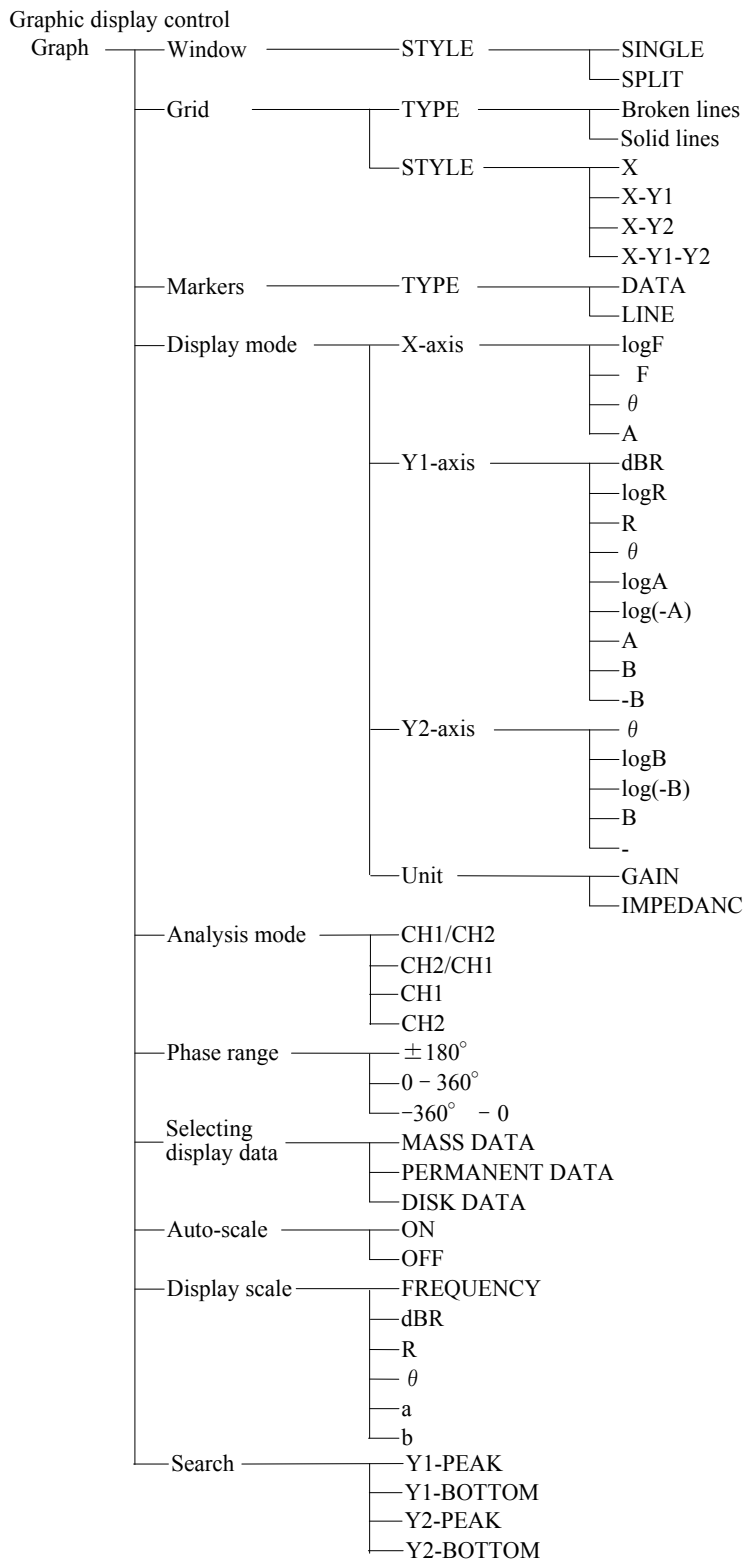

Calculation

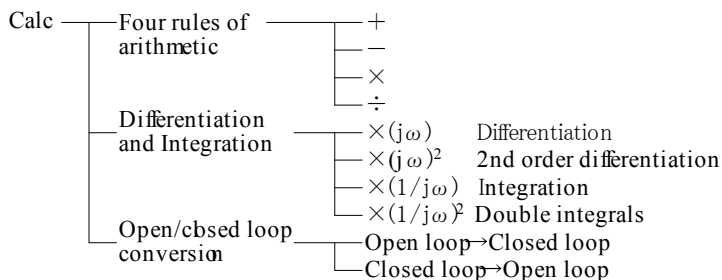

Memory

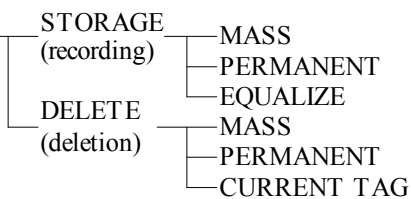

Output control

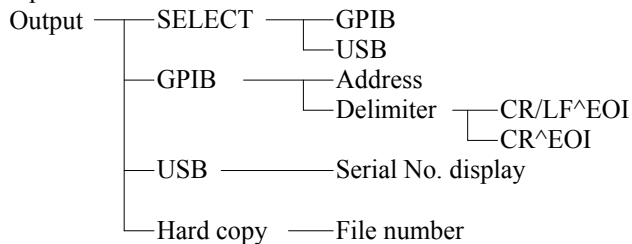

Disk

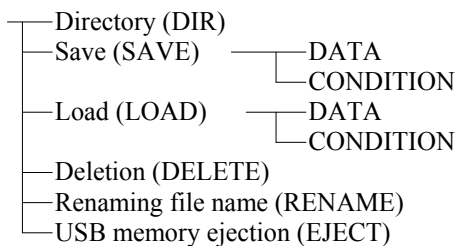

Calibration



Automatic sequencing

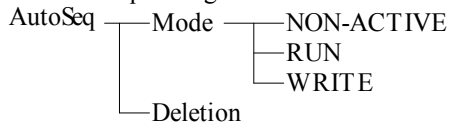

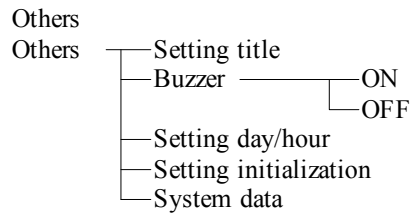

1.4 Principle of operation

1.4.1 Basic principle

The Frequency Response Analyzer (hereafter called FRA) is an instrument that provides measurement of the frequency transfer characteristics of Systems Under Test (hereunder called SUTs) with high accuracy/resolution for wide dynamic range. The FRA is equipped with a sweep oscillator and two channels of analysis input (CH1 and CH2) and calculates, accurately and with high resolution, vector quantity (amplitude and phase) of each analysis frequency component from the Fourier coefficient that is obtained through the discrete Fourier transform of the input signal to be analyzed. The input signal and the output signal of the SUT are entered into individual analysis input terminals (CH1 and CH2), respectively. Then, vector ratio calculation (CH1/CH2) is made to produce the gain and the phase of the signals at the angular frequency ω for which the SUT is to be analyzed.

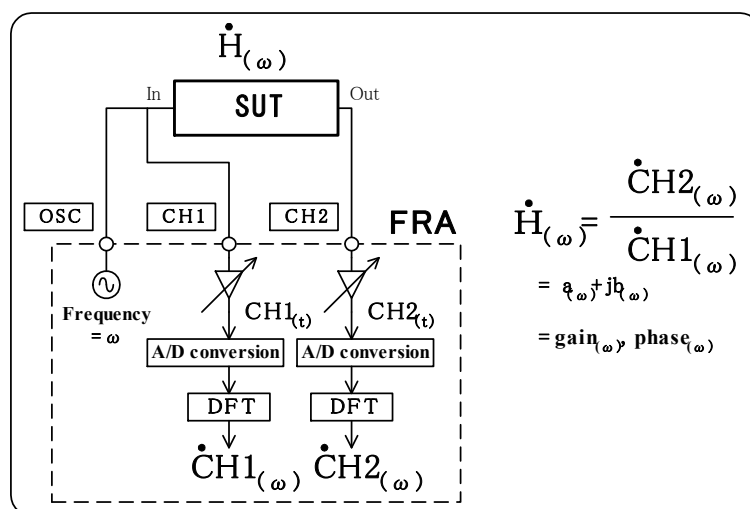

Fig. 1-1 Measurement of frequency transfer characteristics with FRA

At one time of measurement, the gain and the phase only at the analysis frequency ω , which is the oscillator output frequency, will be measured. The frequency characteristics like the Bode diagram will be obtained by sweeping the analysis frequency and thus accumulating the values of the amplitude and the phase of CH1 and CH2 at individual frequencies. At respective analysis frequencies, the preamplifier gain will be readjusted to be most appropriate for the coming measurement, and therefore, the measurement with a wide dynamic measurement range and also with the optimum signal-to-noise ratio will be performed, due to addition of the A/D converter dynamic range and the gain variation range of the preamplifier.

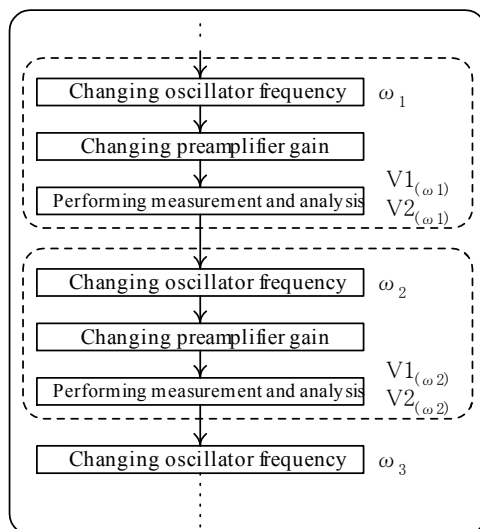

Fig. 1-2 Frequency sweep measurement with FRA

In addition, the discrete Fourier transform used for the FRA analysis has the following features:

- The discrete Fourier transform itself has a steep band-pass characteristic, and therefore, the effect of noise and harmonics will be reduced.
- Measurement can be made within the time period that corresponds to the period of the analysis frequency, since only about one (1) second is needed to measure the amplitude and phase for 1 Hz.
- The freedom of setting measurement frequencies (frequency sweep density) is large, that is, selection between linear/logarithmic sweep is possible, the number of measurement points per sweep can be set as you like, etc.

1.4.2 Block diagram

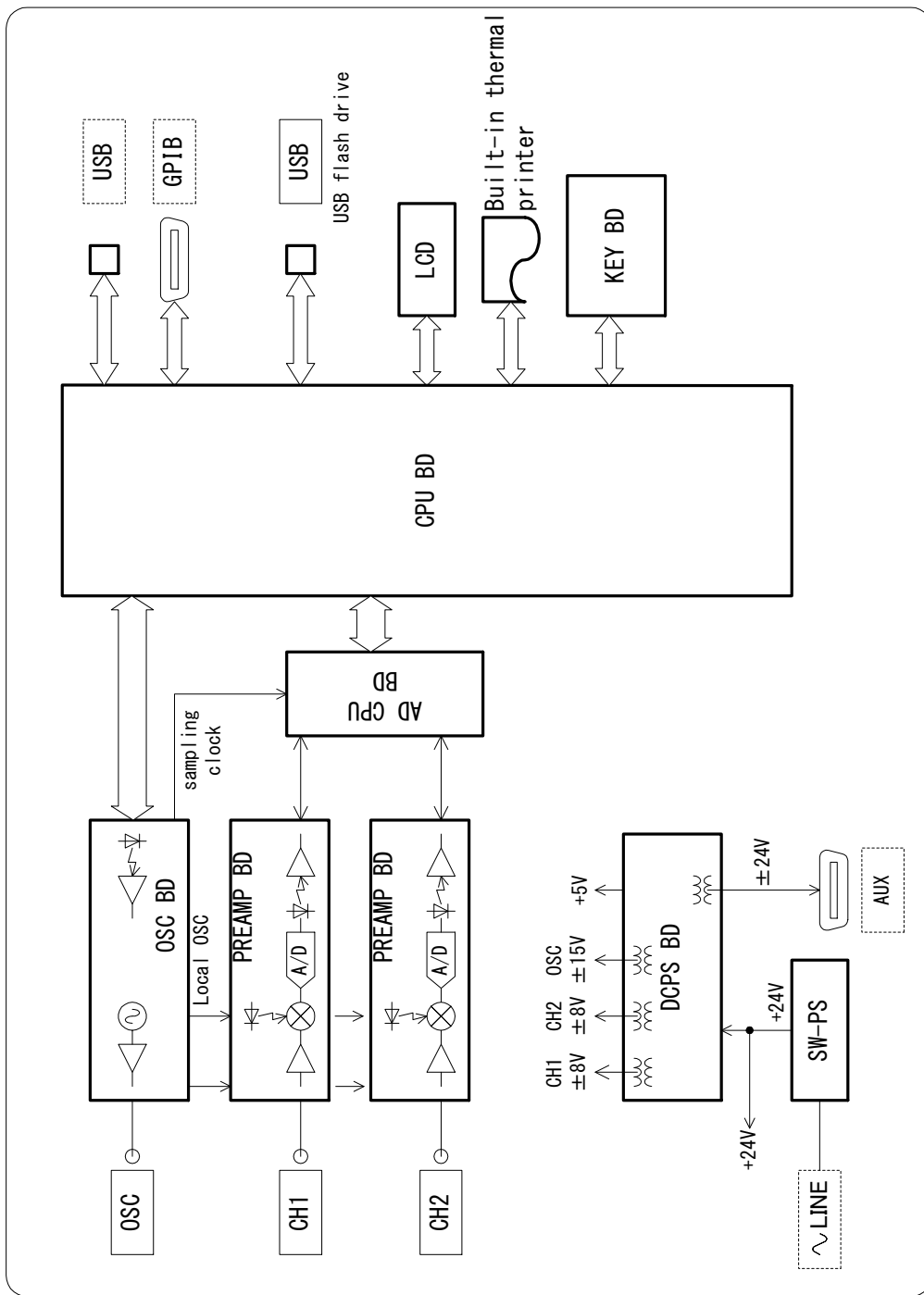

Fig. 1-3 FRA block diagram

Operation of the FRA5097 Frequency Response Analyzer will be described according to “**Fig. 1-3 FRA block diagram**”.

a) OSC BD

This is an oscillator that generates timing signals for this instrument.

The OSC BD generates the three following types of signals: sampling clock signals for A/D conversion, local frequency signals for heterodyne and oscillator output signals.

This oscillator has a setting resolution of 0.1 mHz (1 mHz at 10 MHz or higher) for the frequency range of 0.1 mHz to 15 MHz, due to its use of direct digital frequency synthesizer technology using dedicated LSIs. It has features of, for example, capability of instantaneous frequency change with phase continuity, etc.

b) PREAMP BD

The PREAMP BD is a type of preamplifiers composed of an amplifier with variable gain and an A/D converter.

The input signal will have its DC component removed and be amplified or attenuated to an appropriate level to be A/D-converted to a 16-bit signal. If the analysis frequency is below 3 kHz, the signal will be directly A/D-converted. If the analysis frequency is above 3 kHz, the signal will be A/D-converted after it is converted to the intermediate frequency of approximately 55 Hz through a frequency conversion circuit.

c) AD CPU BD

The digital data signal that has been A/D-converted through the PREAMP BD will be Fourier-integrated and stored as measurement data in the AD CPU BD. The AD CPU BD contains a 16-bit CPU and controls the auto-range function of PREAMP BD, which is in addition to its function of Fourier integration.

d) MAIN CPU BD

The MAIN CPU BD reads measured data from the AD CPU BD, performs coordinate transform, error compensation, etc. and displays the outcome on the LCD. It also controls the keyboard, the floppy disk and the GPIB.

e) DCPS BD

The DCPB BD supplies isolated electric power with high impedance to the CH1/CH2 preamplifier and the OSC.

2. Preparations before use

2.1	Inspection before use	2-2
2.2	Mounting and installation	2-3
2.2.1	Location of installation	2-3
2.2.2	Criteria for location of installation	2-3
2.2.3	Rack mounting	2-4
2.3	Grounding and power supply connection	2-8
2.4	Compliant standards	2-9
2.5	Quick function checking	2-10
2.5.1	Checking functions and indications at power “ON”	2-10
2.5.2	Checking responses for key actions	2-10
2.6	Calibration	2-11

2.1 Inspection before use

■ Ensuring safety

First of all, please read the following Chapters of this Instruction Manual by all means to ensure the safety of users and operators:

- **“Safety Instructions: To safely use the frequency response analyzer”** (This Chapter appears at a very early portion of this Manual.
- **“2.3 Grounding and power supply connection”**

■ Inspection of external appearance and accessories

If you find anything wrong (e.g., any damages or dents) with the external surface of the cardboard box container, please be extremely careful to ensure that the instrument has not been affected, when you open the container and take out the content.

Please inspect the instrument carefully after taking it out from the cardboard container.

If you find any damages in external appearance or anything missing for accessories, please contact NF Corporation or NF’s agent/dealer.

● Checking external appearance:

Check whether or not the instrument has any damages or dents on the panel surface, or at knobs or connectors.

● Checking accessories:

Shown below is a list of accessories of this instrument. Ensure that there is nothing missing and nothing damaged for the accessories.

Table 2-1 Accessories

FRA5097 Instruction Manual	1
FRA5097 GPIB/USB Instruction Manual	1
Mains supply cord (with 3 pin plug, 2 m)	1
Signal cable (BNC-BNC 50 Ω 1 m, 250 Vrms CAT I)	3
(High voltage BNC cable Model name: PC-002-3347)	
T-shaped divider (250 Vrms CAT I)	1
Thermal paper	1
USB flash drive	1

* The accompanying signal cable is equivalent to high withstand voltage BNC cable PC-002-3347 (sold separately).



High voltages appear at some parts of inside of the instrument. Therefore, do not remove the cabinet/cover from the instrument.

Note that no one is allowed to touch the inside of the instrument except for the service persons certified by NF Corporation, even if you need to check its inside.

2.2 Mounting and installation

2.2.1 Location of installation



CAUTION

Take the following precautions to prevent damage to FRA5097.

- FRA5097 is cooled by forced air-cooling. It is requested to install the instrument 10 cm apart from the wall at minimum. If you notice the fan stopped, remove immediately the power supply and report to NF Corporation or NF's agent/dealer.
 - FRA5097 must be installed horizontally (with the bottom panel facing the floor). Using the instrument to be toppled down easily, leading to a danger.
-

2.2.2 Criteria for location of installation

- a) Use the instrument under the following range of temperature and humidity environment.

Note that the pollution condition is degree 2.

Environmental temperature: 5 to +35 °C

Environmental humidity: 5 to 85 % RH (relative humidity) , 1 to 25 g/m³ (absolute humidity)

Use the instrument under the environment without dew condensation.

- b) Do not install the instrument at locations as follows:

- Environment with flammable gas

If the instrument is placed in environment with flammable gas, there will be a high risk of explosion. Never install, use or operate the instrument in such environment.

- Places with direct sunshine or near fire or heat sources

If the instrument is installed or operated at a place with direct sunshine or near fire or heat sources, it may not meet the performance specifications or instrument failures may be induced.

- Environment with corrosive gas, moisture or dust, or with high humidity

If the instrument is installed in such environment, it could be corroded or instrument failures could be caused.

- Places near high voltage equipment, power cables or high electromagnetic field sources

Operating the instrument at such a place could cause malfunctions and/or measurement errors.

- Environment with vibration

Operating the instrument in such environment could cause malfunctions and/or failures.

In addition, signal cables for measurement shall be so routed that they will be immune from interference/induction with noise or electric power by separating them from mains supply cords of this instrument or otherwise. If signal and mains supply cords are routed close to each other, there could be malfunctions and/or measurement errors.

2.2.3 Rack mounting

The FRA5097 Frequency Response Analyzer can be mounted on the 19-inch IEC, EIA or JIS standard rack by the use of a rack-mount adapter (option).

First, mount the rack-mount adapter on the instrument as shown in “**Fig. 2-2 Mounting rack-mount adapter**”, and then, mount the instrument on the rack.

Remove foot-stands from the instrument by placing it upside-down as shown in “**Fig. 2-3 Removal of foot-stands**”, when the foot-stands interfere with the bottom of the rail.

Following attention should be drawn when you mount the instrument on the rack:

- Support the instrument by all means by installing some supports such as rails on the rack.
- Do not mount this instrument on an enclosed rack; otherwise, internal temperature rises high enough to induce operational failures.
Prepare ventilation openings on the rack, or install an air flow system in the rack by using a fan.
If you install other equipment above and/or below this instrument in the rack, secure the space of 40 mm at minimum between the lower equipment for ventilation purposes.
- A space above the FRA5097 is required for replacing the thermal paper roll when the built-in thermal printer is used.
See “Figure 9-1 External Drawing” for how to secure a space that allows the lid of the printer unit to be opened and closed.

2.2 Mounting and installation

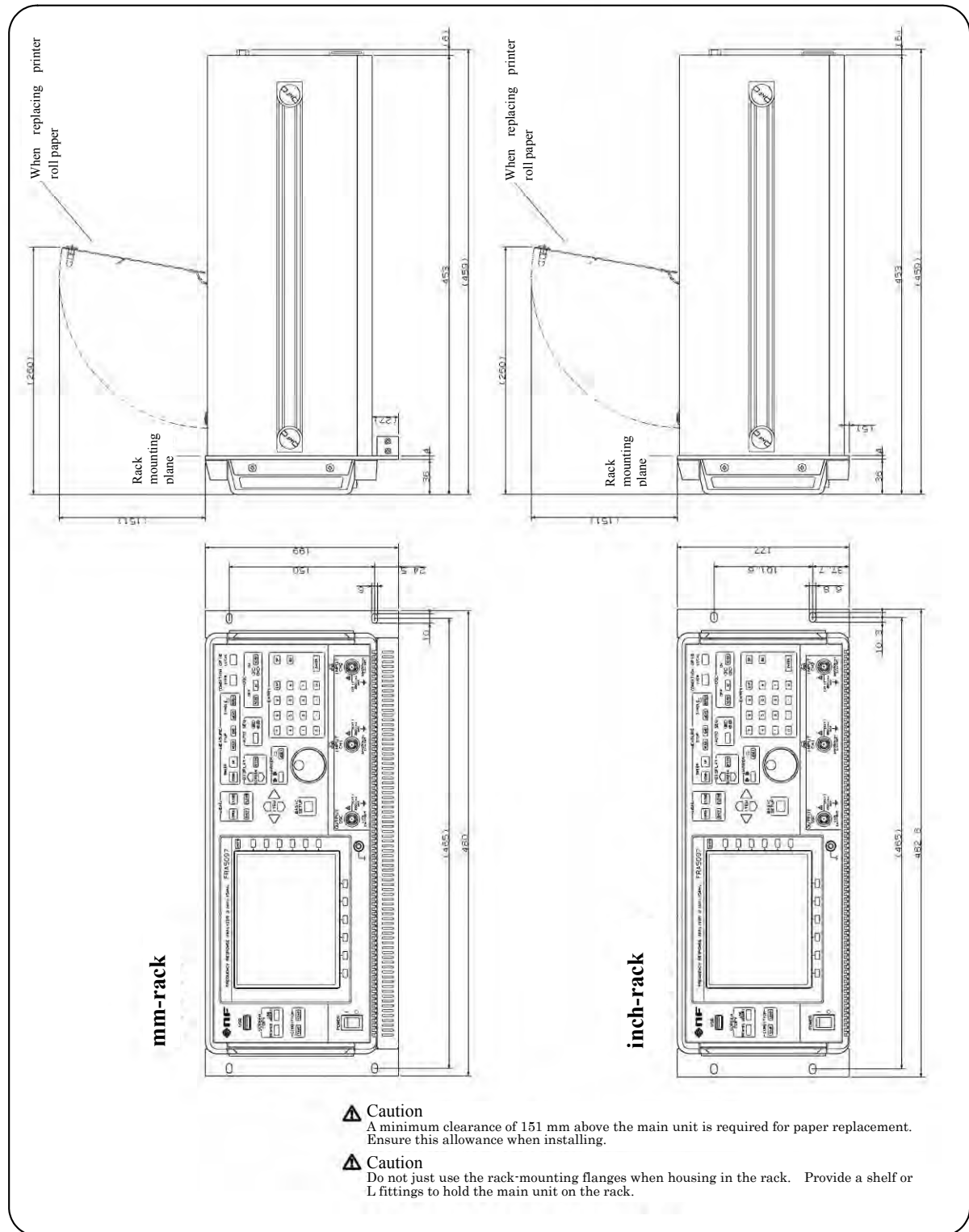

Fig. 2-1 Size and dimensions of FRA5097 rack mount

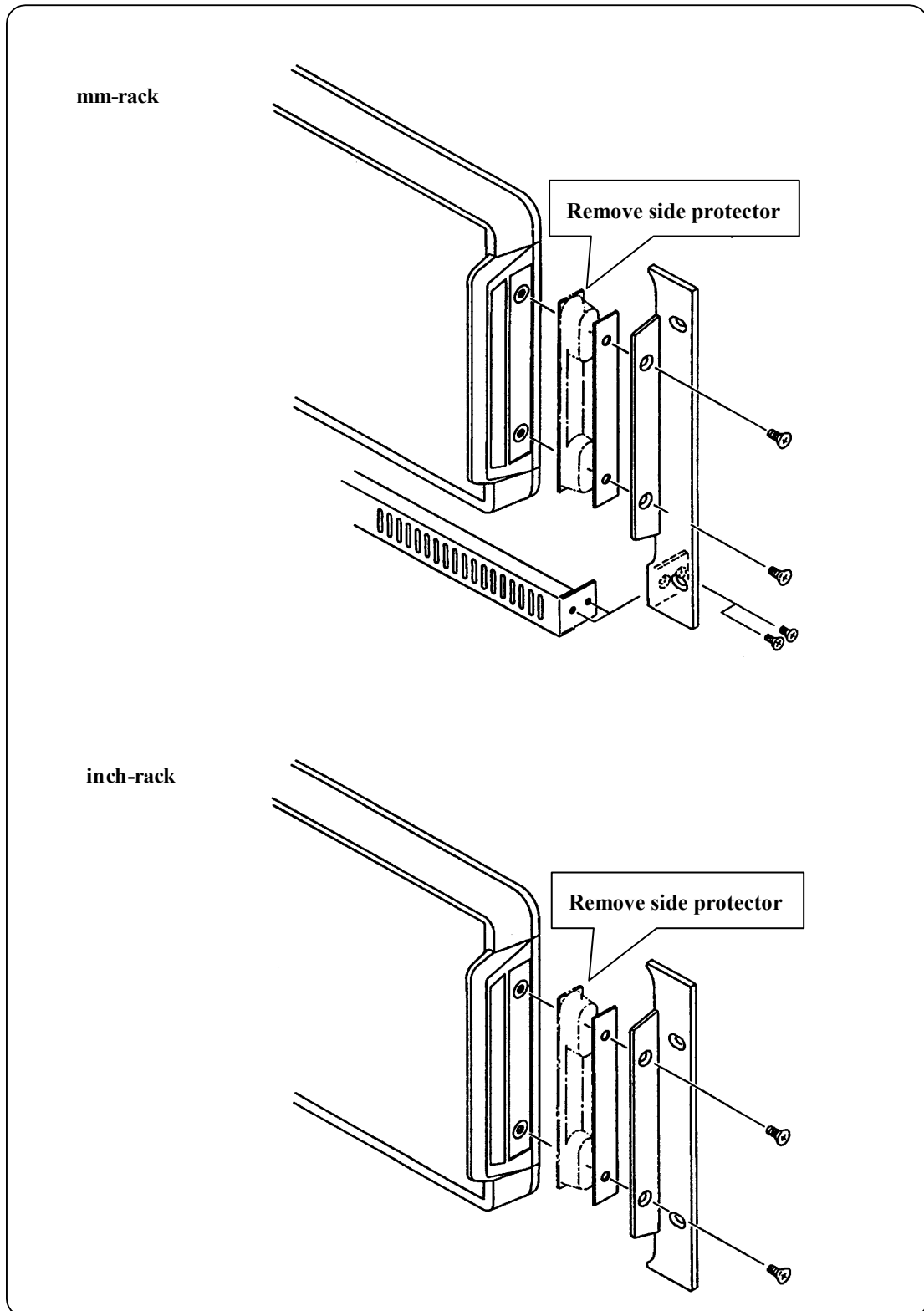

Fig. 2-2 Mounting rack-mount adapter

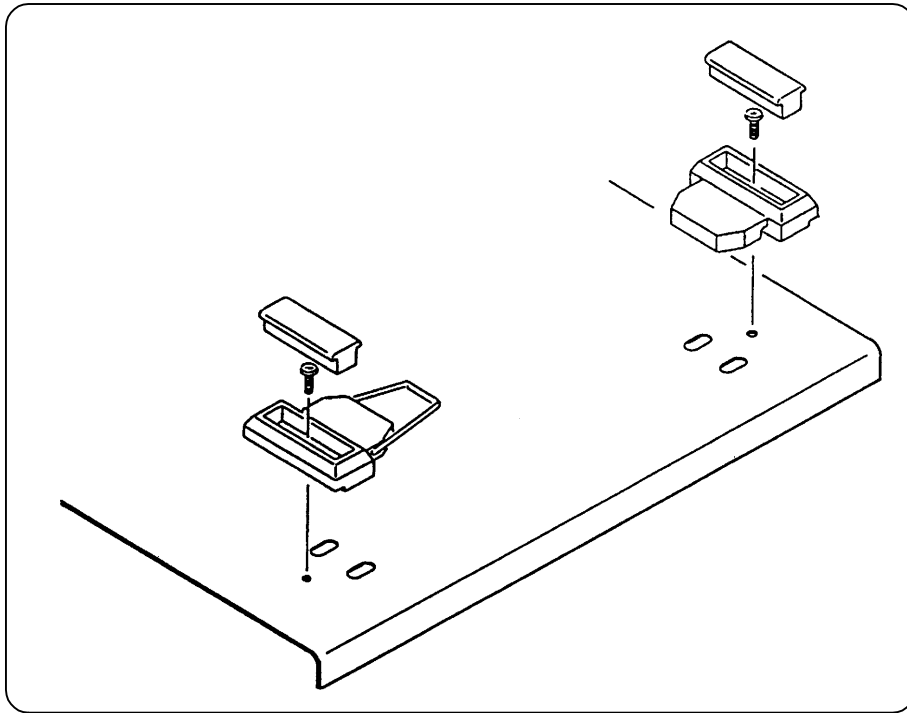

Fig. 2-3 Removal of foot-stands

2.3 Grounding and power supply connection

- Ground the instrument by all means.



Note the following precautions to prevent electric shock.
Before connecting the unit to perform measurements, always connect the protective grounding terminal to a grounding contact.
This instrument's protective grounding terminal is the grounding plug pin of the mains supply cord.

■ **The power supply conditions of this instrument are the following:**

- Allowable range of voltages : AC 100 V/120 V/230 V $\pm 10\%$, 250 V or lower
- Allowable frequency range : 50 Hz/60 Hz ± 2 Hz
- Consumption power : 100 VA max.
- Overvoltage category : II

■ **The following procedure shall be taken to connect the power supply:**

- 1) Confirm that the commercial power source voltage is within the allowable voltage range of the instrument to be connected.
- 2) Set the power supply switch of this instrument at the “OFF” position.
- 3) Connect the mains supply cords female-plug into the power supply connector located at the rear of this instrument.
- 4) Connect the mains supply cords male-plug into the three-pole power source outlet.

 **CAUTION**

The mains supply cord attached to this instrument is exclusively used with the instrument only. Do not use this mains supply cord for other equipment or purposes.

2.4 Compliant standards

FRA5097 complies with the following standards.

Safety standard	: EN61010-1:2010 EN61010-2-030:2010
EMC	: EN61326-1:2013(Group 1, Class A) EN61000-3-2:2006+A1:2009+A2:2009 EN61000-3-3:2013

The following cables are used during the EN61326:1997/A1:1998/A2:2001/A3:2003 tests.

- Mains supply cords : Accessory
- Signal cable : Accessory
- T-shaped divider : Accessory
- GPIB cable : Shielded cable, one meter (DDK: 408Je-101)
- USB cable : USB 2.0 standard compliant cable, 1 meters (Sanwa Supply, KU20-1)

2.5 Quick function checking

This section introduces quick function checking methods for this instrument to be used for quickly checking important functions of the instrument after delivery or long period of time of storage.

Refer to “8. Maintenance” for more detail on instrument check-out.

2.5.1 Checking functions and indications at power “ON”

When you first throw power supply “on”, all the lamps on the panel will be lit on. Confirm that there are no lamps that are not lit. At the same time, the initialization pattern and the opening message are displayed on the LCD screen, and then, the calibration and system-check windows will be displayed on the screen. (The calibration window is for self-measurement to correct for any errors.) After the system-check has been successfully completed, the window will automatically be closed.

- **For more detail on lamp indications at the time of power supply “ON”, refer to “3.2 Display at power “ON” and initial settings”.**
- **For more detail on error messages, refer to “6.1 Error messages”.**



WARNING

Smoke, odor, strange sound

In such event, immediately disconnect the power cable from the outlet and do not use the equipment until repairs are completed.

2.5.2 Checking responses for key actions

Check and ensure that all important keys function properly.

Check and ensure that the lamp at the left of **AC/DC ON** key is properly lit on and out (on/off) at each time you push the keys of **AC/DC ON**, **AC/DC OFF** and **AC OFF** under the -OSC- indication which is located on the right hand side of the panel.

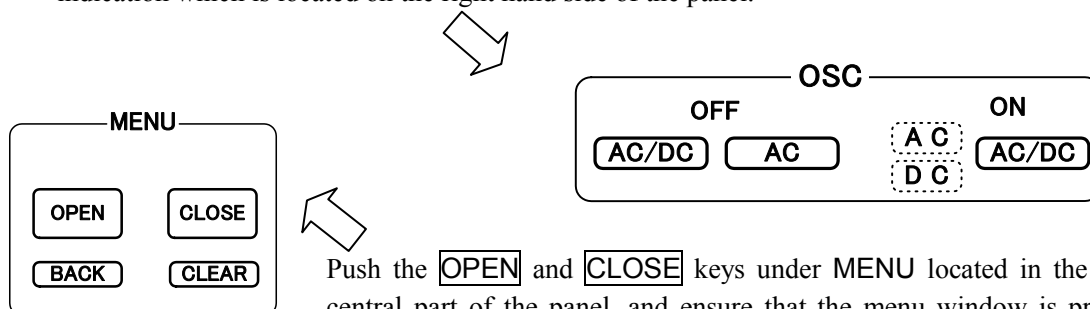

Push the **OPEN** and **CLOSE** keys under **MENU** located in the upper central part of the panel, and ensure that the menu window is properly displayed and closed on the LCD screen.

Confirm also that key clicking sound can be heard at each time you press a key.

2.6 Calibration

Although somewhat contingent on the usage environment and how often the FRA5097 is used, conduct the performance tests of Section 8.5 at least once a year. The performance tests are also recommended immediately before using the equipment for important measurements or testing. Refer the performance tests to technicians possessing experience in operating measuring equipment and have a good general knowledge of instrumentation.

(Blank)

3. Descriptions on Panels and basic Operations

3.1	Panel descriptions	3-2
3.1.1	Front panel	3-2
3.1.2	Rear panel	3-9
3.1.3	Top panel	3-9
3.2	Display at power “ON” and initial settings.....	3-10
3.2.1	Displays and indications at power “ON”	3-10
3.2.2	Initialization	3-12
3.2.3	Warm-up	3-15
3.3	Input and output terminals	3-16
3.4	Insulation breakdown voltages of input and output voltages.....	3-19
3.5	Examples of basic operations	3-21
3.5.1	Menu operation	3-21
3.5.2	On/off operations for oscillator output.....	3-25
3.5.3	Examples of basic measurement operations	3-26
3.5.4	Examples of connections	3-30
3.5.5	High frequency measurement	3-33

3.1 Panel descriptions

This section describes labels, functions and operations of various parts of the panels (i.e., the front panel, the rear panel and the top panel) of the FRA5097.

3.1.1 Front panel

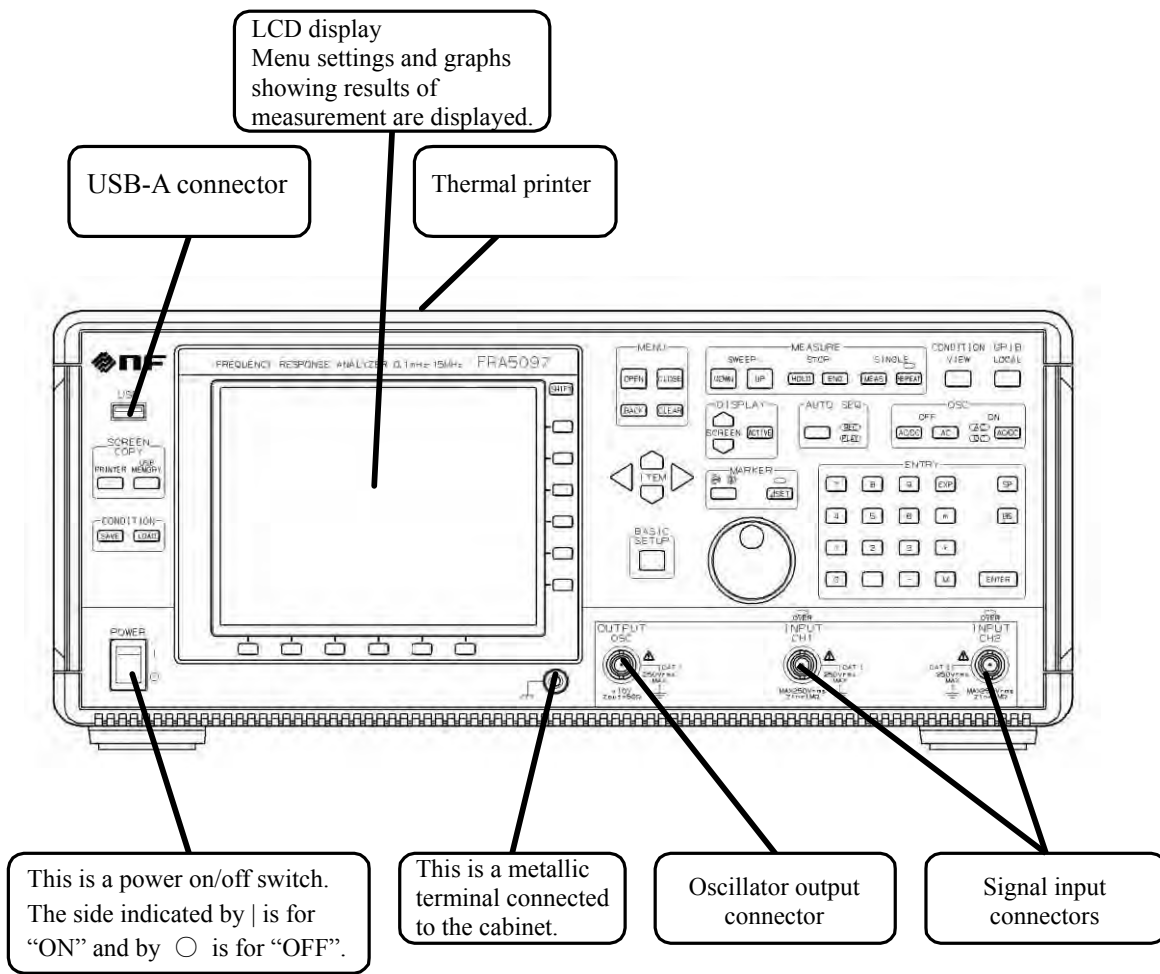



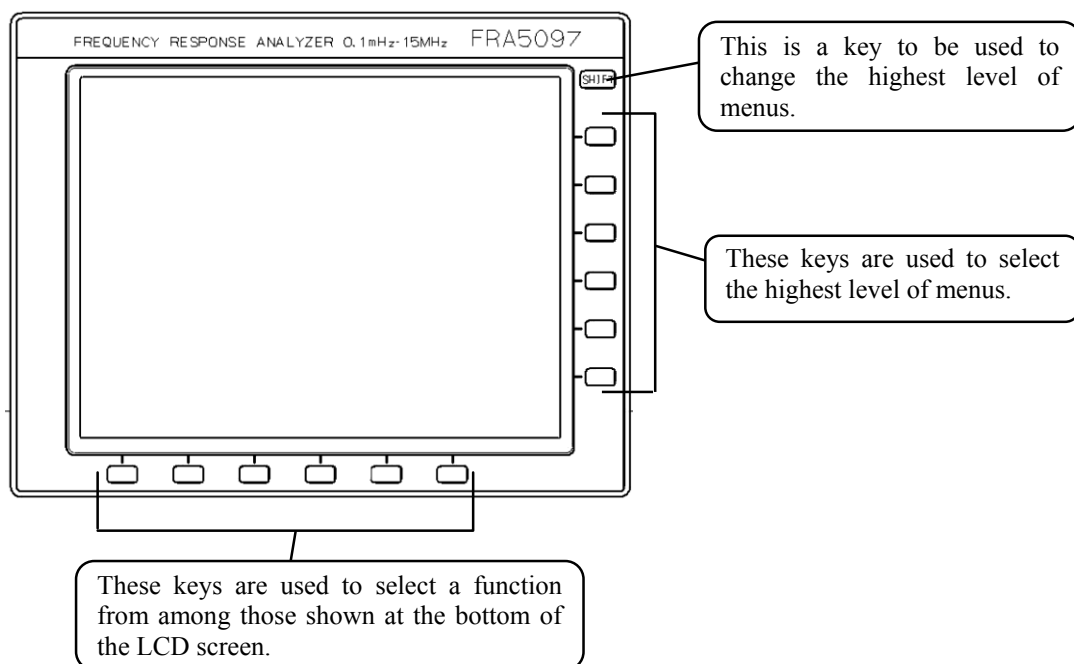

● Around LCD

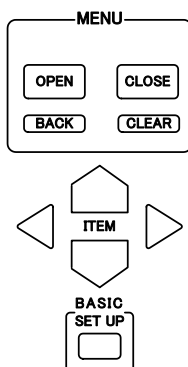

● Menu operation keys



- **OPEN** : Menus lower than the selected menu in level, or a table are displayed.
- **CLOSE** : The current menu is closed and a higher level menu (by one level) is displayed.
- **BACK** : This key is used to display, one after another, ten newest window displays in the window that has been displayed right after power switched "ON".
- **CLEAR** : This key closes all menu windows.
- **ITEM** :  and  keys are used to shift the menu item to be selected, and  and  keys are used to shift the item to be selected in the table.
- **BASIC SETUP** : This is a shortcut menu that allows ready retrieval of the parameters frequently set or revised in the FRA5097.

● SCREEN COPY

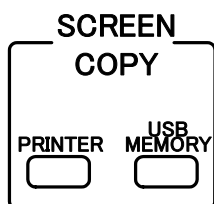

- **PRINTER** : This key is used to output the current LCD display to the built-in thermal printer to produce a hard copy.

For more detail, refer to “4.14 Output to printer”

- **USB MEMORY** : This key is used to output a hard copy of the LCD screen to the USB flash drive.

For more detail, refer to “4.15 Output to USB Memory”.

● Loading/saving measurement conditions

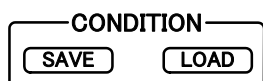

This feature allows you to load or save the FRA5097 setting by a simple operation. The number of measurement condition sets that can be loaded or saved by these keys is limited to one.

- **SAVE** : Saves the current FRA5097 measurement conditions in the USB flash drive. The save file name is “CORRENT.CON” fixed.
- **LOAD** : Loads the measurement condition file from the USB flash drive, and changes the FRA5097 setting accordingly. The loaded file name is “CORRENT.CON” fixed.

You can load or save measurement conditions under an arbitrary file name.

For more detail, refer to “4.17 File operation”.

● Auto-sequence





A series of key operations is recorded, and the series is automatically executed in sequence as recorded. While key operations are being recorded, the REC lamp is lit (on); and the play lamp lights while automatic sequence execution is being done.

For more detail, refer to “4.12 Auto-sequence”.

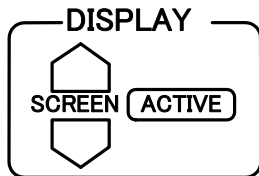
● Display control key





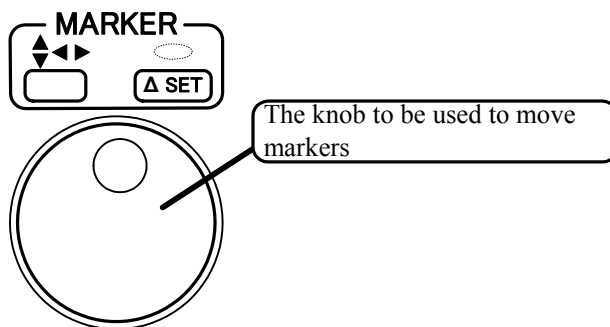

- **SCREEN** : The FRA5097 has six (6) classes of display screens, one of which can be displayed by using this key. The selected screen is indicated by a blue-colored screen tag number at the left of the graph displayed screen. The selected tag number moves up and down with  and  keys, and the corresponding screen is displayed.
- **ACTIVE** : The FRA5097 has a capability of displaying two (2) graphs at the same time on one screen, by splitting the screen into two (upper and lower parts). The key is used to alternatively select an active graph. The graph surrounded by blue border is active and will be rewritten when a measurement is made. In addition, the marker is valid only for the active graph.

For more details, refer to “4.6.1 Setting display format”.

● Marker control key and knob



These keys and knob are valid only when markers are displayed on the screen.

-  : This key is used to select an active marker (i.e., x-axis marker or y-axis marker), while line markers (i.e., lines that are parallel to x and y axes) are displayed. At every time when the key is pressed, a lamp on  or  is lit alternately. When you select the key , the y-axis marker becomes active, and when the key  is selected, the x-axis marker becomes active. Either when the marker is off or when the data marker is displayed, this key is invalid and the lamp is also off (not lit).
- **ΔSET** : This key is used to set the delta mode. At every time this key is pressed, the ΔSET lamp will be on and off alternately; the lamp is on at the delta mode and the lamp is off when the mode is off.
- Knob : The knob is used to move an active marker.

For more details, refer to “4.6.4 Setting markers”.

● Measurement control

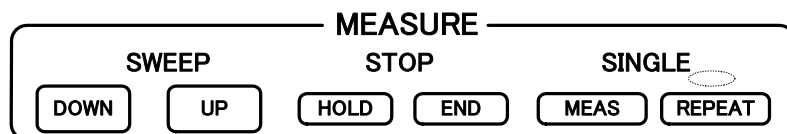

- **DOWN** **UP** : The **DOWN** key is used to start frequency sweep operation from the upper frequency limit in the sweep range toward lower frequencies, and the **UP** key is used to start frequency sweep operation in the opposite direction; i.e., from the lower frequency limit toward upper frequencies. These keys can also be used to change the sweep direction if you press one of these keys during sweep operation.
- **HOLD** : This key is used to stop/hold an ongoing sweep operation midway. Press the **DOWN** or **UP** key to restart the sweep operation. Press this key to terminate the REPEAT measurement operation when the REPEAT measurement operations being made.
- **END** : Press this key to terminate the sweep or REPEAT measurement. Press the **DOWN** or **UP** key after pressing this key during sweep measurement operation, to clear the current graph and to newly start sweep operation.
- **MEAS** : This key is used to make a measurement at a fixed frequency. Press this key while the REPEAT lamp is off to conduct measurement at the currently set frequency (SINGLE measurement) and then to display an enlarged measured data at the center of the LCD screen at the end of measurement. Press this key while the REPEAT lamp is on to repeat measurements at the same frequency (REPEAT measurement).
- **REPEAT** : Press this key to light the REPEAT lamp on, and then, press the **MEAS** key to repeat measurements at a fixed frequency. At every time when you press the key, the REPEAT lamp will be on and off alternately.

● Measurement condition display



Press this key to display the measurement condition for the currently displayed graph in a window on the right-hand half of the LCD screen. The key functions with an alternative mode, so that the window display on and off alternately at every time when the key is pressed.

For more details, refer to “4.19 Condition display”.

- **GPIB local key**



Press this key to turn the panel control mode back to the GPIB/USB local mode from the GPIB remote mode. Note that this key is invalid during the local lockout (LLO) condition.

For more details, refer to “FRA5097 GPIB/USB Instruction Manual”.

- **Oscillator control**

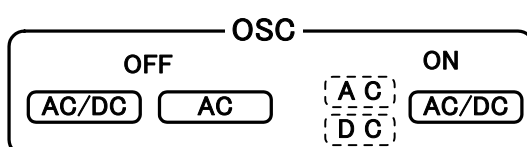

- **AC/DC OFF** : Press this key to turn off the output voltage. Both the AC and DC lamps will be lit off.
- **AC OFF** : Press this key to turn off only the alternate current component of the output voltage. Only the AC lamp will be lit off.
- **AC/DC ON** : Press this key to turn on both the AC and DC lamps and to output signals from the oscillator. Once you have changed the output voltage settings, the output voltage will not change until you press this key, even when both AC and DC lamps are lit (on).

For more details, refer to “4.5 Oscillator setting”.

⚠ CAUTION

When you want to change the output voltage, press the **AC/DC ON** key by all means.

● Register key

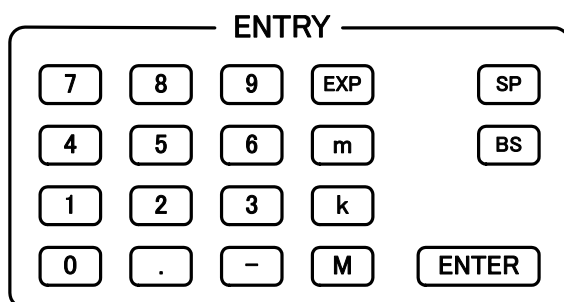

These keys are used to register setting parameters.

- **0** ~ **9** **.** **-** : These keys are used to enter numerical values.
- **M** **k** **m** : These keys are used to indicate 10^6 , 10^3 and 10^{-3} , respectively.
- **EXP** : These keys are used to enter numerical values in the exponential representation.

The values entered in the register by using the keys mentioned above will be displayed in the register display portion located at the bottom of the LCD display screen.

- **SP** : This key is used to enter “space” in the character ring, e.g., titles. Note that this key is invalid when you are entering numerical values.
- **BS** : This key functions as a back-space key that deletes the last entered character in the character ring or numerical values and puts the cursor back by one character.
- **ENTER** : This key is to execute settings of the character string or numerical values that have been entered/registered. The setting continues unchanged until this key has been pressed.

3.1.2 Rear panel

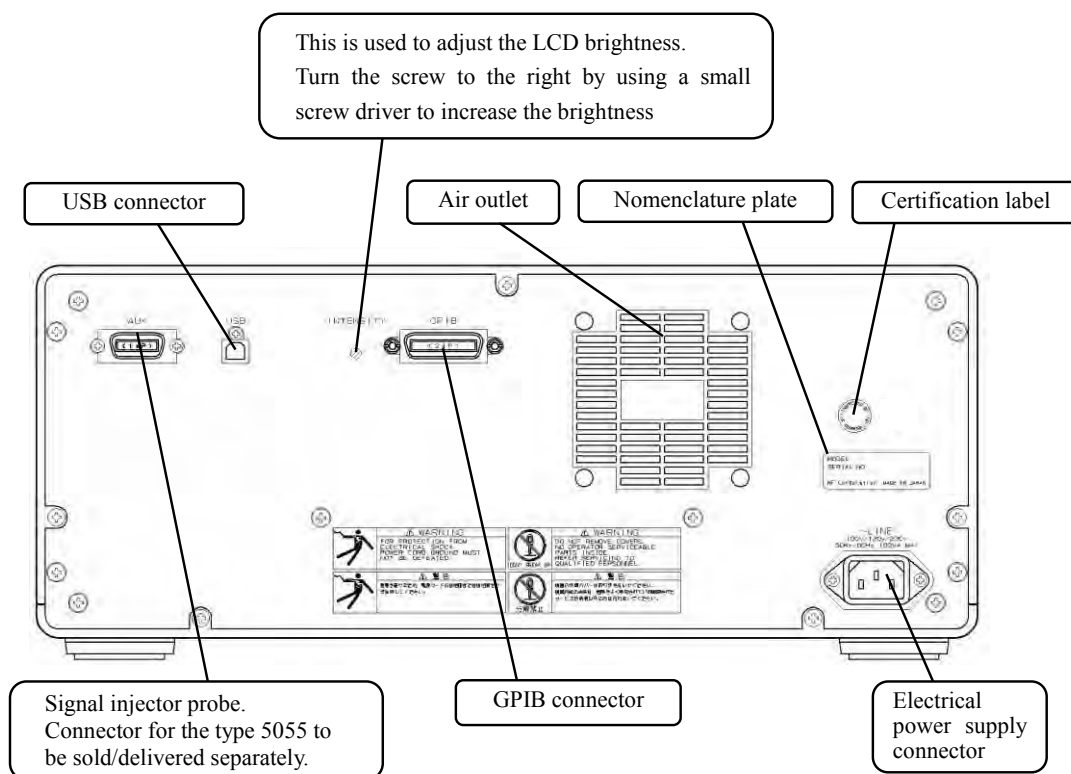

3.1.3 Top panel

The top panel cover can be opened for changing the printer paper. **Refer to 4.14 Output to Printer** for printer operation and paper change.

3.2 Display at power “ON” and initial settings

3.2.1 Displays and indications at power “ON”

Take necessary steps before instrument usage/operation according to “**2. Preparations before use**”.

Upon your turning power supply switch “on”, the FRA5097 will conduct its self-diagnosis testing. During the self-diagnosis, all the front panel lamps will be lit on and the following will be displayed on the LCD screen:

Testing Memory	ROM
Testing Memory	RAM

The following are the errors that can be displayed through self-diagnosis:

- ROM errors or RAM errors

When the above error information is displayed, the CPU has failures in its ROM or RAM and the FRA5097 does not function nor operate.

- Keyboard subsystem error.

This shows that the keyboard subsystem has failures.

- A/D subsystem error.

This shows that you have failures in the A/D subsystem.

Contact and notify the NF representatives when you have one of the three types of errors mentioned above.

- All setup and data were lost, re-initialized

This error information is displayed either when the battery has been discharged and hence the data in the memory, etc. Cannot be maintained, or when the backup data have been destroyed due to some reasons.

In this case all the settings will be initialized and all the data in the permanent data memory will be cleared; thereafter, however, the instrument will function and operate normally.

The period of battery backup is no less than three (3) years under normal room temperature; note, however, that the period depends upon instrument individuality and usage conditions. Contact the NF representatives when you have a problem of data backup due to elapse of the battery life-time, since you need to replace the battery. (You will be charged for the replacement.)

For more details on initialization, refer to “3.2.2 Initialization”.

The front panel lamp extinguishes when self-check is complete. The LCD then shows the opening screen and automatic calibration (Calibration/Systemcheck) is conducted.

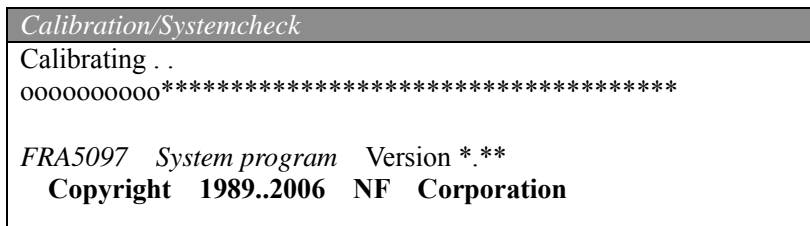

The completion of calibration is indicated by the change of “*” marks into all “o” marks in the “Calibration/Systemcheck” window display, which means that the instrument is ready for operation

The setting values and parameters just before the previous power-off are maintained, except that the oscillator output is off and the measurement is inactive.

If any errors are detected during calibration processes, the word “ERROR” will be displayed in red characters (see the arrow → the figure) in the “Calibration/Systemcheck” window, and the FRA5097 does not function/operate.

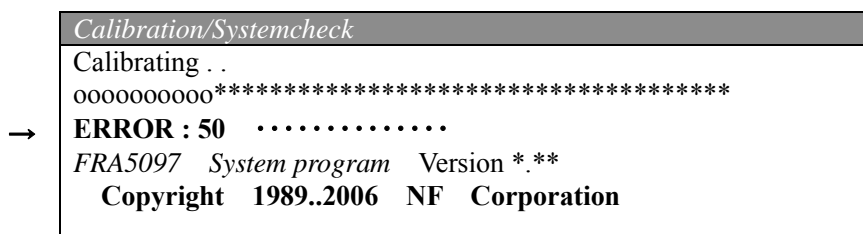

The following are possible causes of calibration errors as mentioned above:

- **Effect of external noise**

During calibration processes, measurement is made within the instrument by connecting the oscillator output and the analyzer input internally. A calibration error could be caused if a high level of external noise comes in at any time during the internal measurement. If the calibration error exceeds a certain predetermined range (threshold), an error message will be displayed and the instrument will be put in an inoperable status, since the measurement accuracy cannot be maintained.

(Actions/measures to be taken)

- Use the instrument in a low noise environment.
- Switch on the power supply again after disconnecting a signal cable with BNC connectors from the oscillator output and the analyzer input. This can isolate the noise source if noise has been induced in the signal cable.

- **Failure of FRA5097**

If a calibration error is indicated even after the above measures, malfunction of the FRA5097 is suspected. Contact NF Corporation or its representative to arrange for repair.

3.2.2 Initialization

The FRA5097 is initialized at the following situations:

- At the time of shipment from factory
- When backup data destruction due to battery discharge has been detected at power supply switch on.
- When you set up the initialization through the menu [Others]-[INITIALIZE].
- When the instrument has received an initialization command: “SEtup Initialize”.

The oscillator output is set at “OFF” at the initialization. The other initialization values and parameters are shown in “**Table 3-1 List of initialization values**”. The items that are set at initialization values are indicated by the mark “○”, and those that are unchanged are indicated by the mark “-” in the Table.

Table 3-1 List of initialization values (continued)

Setting items	Initialization values	At shipment from factory	At data destruction	At initialization executed	Notes/Remarks
OSC					
FREQUENCY	1 kHz	○	○	○	Oscillation frequency
AMPLITUDE	1 V _{peak}	○	○	○	Amplitude
DC BIAS	0 V	○	○	○	DC bias
STOP MODE	ZERO	○	○	○	
ON/OFF MODE	QUICK	○	○	○	
START/STOP PHASE	0 deg	○	○	○	
WAVE FORM	SINE	○	○	○	Sinusoidal waveform
MEASURE					
SWEEP FUNCTION					
MAX FREQUENCY	100 kHz	○	○	○	Maximum sweep frequency
MIN FREQUENCY	10 Hz	○	○	○	Minimum sweep frequency
SWEEP RESOLUTION	LOG 100steps/sweep	○	○	○	Sweep frequency resolution
MANUAL SWEEP	OFF	○	○	○	
BASIC FUNCTION					
INTEGRATION	1 cycle	○	○	○	Integration period
DELAY	0 cycle	○	○	○	Delay period
EQUALIZING	OFF	○	○	○	
OPEN CORRECTION	OFF	○	○	○	
SHORT CORRECTION	OFF	○	○	○	
HARMONICS	1	○	○	○	
MEASURE MODE	CH1, CH2	○	○	○	
COHERENCE MODE	CH1&CH2	○	○	○	
SLOW SWEEP					
FUNCTION	OFF	○	○	○	
SLOW SWEEP MODE	MANUAL	○	○	○	
CHANNEL	CH1	○	○	○	
VARIATION	dBR 10 dB	○	○	○	
AUTO INTEGRATION					
FUNCTION	OFF	○	○	○	
MODE	SHORT	○	○	○	
MAX INTEGRATION	100 cycles	○	○	○	

Table 3-1 List of initialization values (continued)

Setting items	Initialization values	At shipment from factory	At data destruction	At initialization executed	Notes/Remarks
MEASURE (continued)					
AMPLITUDE COMPRESSION					
FUNCTION	OFF	○	○	○	
REF CHANNEL	CH1	○	○	○	
REF LEVEL	1.00 Vrms	○	○	○	
OUTPUT LIMIT	1.00 Vpeak	○	○	○	
ERROR	10 %	○	○	○	
RETRY TIMES	10	○	○	○	
CORRECTION FACTOR	100 %	○	○	○	
AUTO SEQUENCE					
MODE	NON-ACTIVE	○	○	○	
Sequence parameters	(cleared)	○	○	—	
INPUT					
CH1 LEVEL	250 Vrms	○	○	○	Excessive level detection threshold
CH2 LEVEL	250 Vrms	○	○	○	
ACTION					
BUZZER	OFF	○	○	○	Action taken at excessive level detection
SWEEP STOP	OFF	○	○	○	
OSC OFF	OFF	○	○	○	
WEIGHTING FACTOR					
CH1	1.0000E+00	○	○	○	Input channel weighting factor
CH2	1.0000E+00	○	○	○	
INVERT	OFF	○	○	○	Phase invert function
GRAPH					
FORMAT					
WINDOW STYLE	SINGLE	○	○	○	
GRID	OFF	○	○	○	
GRID TYPE	SOLID LINE	○	○	○	
GRID STYLE	X	○	○	○	
MARKER	ON	○	○	○	
MARKER TYPE	DATA	○	○	○	
DISPLAY MODE					
X – AXIS	logF	○	○	○	
Y1 – AXIS	dBR	○	○	○	
Y2 – AXIS	θ	○	○	○	
UNITS	GAIN	○	○	○	
ANALYSIS MODE	CH1/CH2	○	○	○	
PHASE RANGE	±180 deg	○	○	○	
AUTO SCALING	ON	○	○	○	
SCALE					
FREQUENCY MAX	15 MHz	○	○	○	
FREQUENCY MIN	0.1 mHz	○	○	○	
dBR MAX	40 dB	○	○	○	
dBR MIN	–40 dB	○	○	○	
R MAX	100E+0	○	○	○	
R MIN	0E+0	○	○	○	

Table 3-1 List of initialization values (continued)

Setting items	Initialization values	At shipment from factory	At data destruction	At initialization executed	Notes/Remarks
GRAPH (continued)					
θ MAX	180 deg	○	○	○	
θ MIN	-180 deg	○	○	○	
a MAX	10	○	○	○	
a MIN	-10	○	○	○	
b MAX	10	○	○	○	
b MIN	-10	○	○	○	
CALC					
+ - × ÷					
DATA1	TAG 0	○	○	○	
MODE	<+>	○	○	○	
DATA2	TAG 0	○	○	○	
ANSWER TAG	0	○	○	○	
d/dt: $\int dt$					
DATA TAG	0	○	○	○	
MODE	$\times(j\omega)$	○	○	○	
ANSWER TAG	0	○	○	○	
OPEN/CLOSE					
DATA TAG	0	○	○	○	
Tm	CONSTANT 1.0	○	○	○	
MODE	To/(1+To×Tm)	○	○	○	
ANSWER TAG	0	○	○	○	
OUTPUT					
SELECT	GPIB	○	○	—	
GPIB					
ADDRESS	2	○	○	—	
OUTPUT DELIMITER	CR/LF^EOI	○	○	—	
HCOPY					
FILE NUMBER	000	○	○	○	

Table 3-1 List of initialization values (continued)

Setting items	Initialization values	At shipment from factory	At data destruction	At initialization executed	Notes/Remarks
OTHERS					
TITLE SET	(Cleared)	○	○	-	Also cleared at re-measurement and at power supply switch on
BUZZER	ON	○	○	○	
DATE SET					
YEAR	1988	-	○	-	The actual shipment date is set at shipment from factory
MONTH	1	-	○	-	
DAY	1	-	○	-	
TIME SET					
HOUT	0	-	○	-	The actual shipment time is set at shipment from factory
MINITE	0	-	○	-	

3.2.3 Warm-up

It takes more than 30 minutes after the power supply switching-on for the internal temperature of the FRA5097 to reach stable.

Perform measurement right after calibration is made, which shall be made after sufficient time to warm-up has been made. Note that the measurement accuracy specification is met under the condition immediately after calibration.

Conduct re-calibration when environment temperature has been changed.

3.3 Input and output terminals

■ Analyzer input terminals (CH1 and CH2)

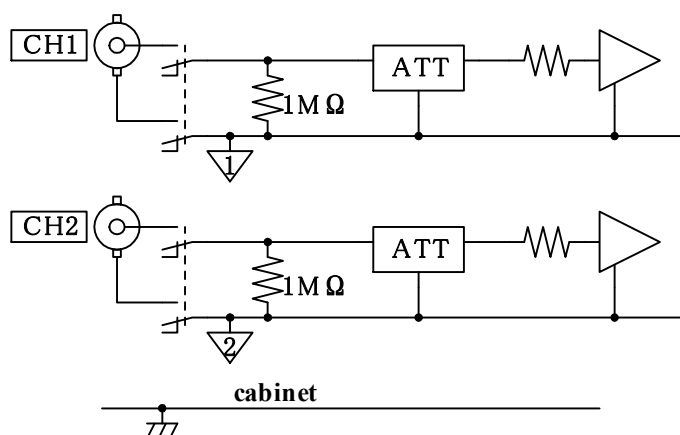

Each of the analyzer input terminals of the FRA5097 is electrically insulated from the cabinet, the oscillator and the other analyzer input terminal. The minimum breakdown voltage is 250 Vrms (measurement category I) between each of the input and output terminals and the cabinet, between CH1 and the oscillator, between CH2 and the oscillator and between CH1 and CH2, respectively when the accompanying insulated coaxial cable is being used. Restriction of 30 Vrms applies when a cable other than the accompanying cable is used. Note that accidents due to electric shocks could occur, if the voltages exceeding the minimum breakdown voltage are applied between the above mentioned insulated parts, leading to dielectric breakdown. Refer to “3.4 Insulation breakdown voltages of input and output voltages” by all means, when you make a measurement where high voltages are applied between any two of the cabinets, CH1, CH2 and the oscillator.

⚠ WARNING

- Do NOT connect to any measurement target that exceeds 250 Vrms of measurement Category I. Doing so may result in insulation breakdown, imposing electrical shock.
- You could be suffered from electric shocks when you measure high voltage circuit signals. Use accessory coaxial cables of the insulation type by all means, so that you cannot directly touch metallic portions of the BNC connectors at the analyzer input terminals.

The input terminals have the input impedance of 1 MΩ (parallel capacitance of 25 pF ± 5 pF) and the maximum allowable input voltage of ±350 V for AC+DC. Never apply any voltages exceeding the maximum allowable voltage, since the inside of the instrument will be damaged by application of voltages exceeding the minimum allowable voltage.

FRA5097 has the capability of measuring the amplitude and the phase of input signals up to 15 MHz. Use the same type and the same length of signal cables to be connected to individual channel inputs so that the phase can be measured with high accuracy at high frequencies.

The connection between the input connector and the internal circuits is cut off when the power supply is off.

■ Oscillator output terminals (OSC)

The oscillator output terminal is electrically insulated from both the cabinet and the analyzer input terminals. The minimum allowable breakdown voltage between the oscillator and either the cabinet or the analyzer input terminals is

250 Vrms (measurement category I), when the accompanying insulated coaxial cable is used. Restriction of 30 Vrms applies, when a cable other than the accompanying cable is used. Note that accidents due to electric shocks could occur, if voltages exceeding the minimum breakdown voltage are applied between the above mentioned insulated parts, leading to dielectric breakdown. Refer to “**3.4 Insulation breakdown voltages of input and output voltages**” by all means, when you make a measurement where high voltages are applied between any two of the cabinets, CH1, CH2 and the oscillator.

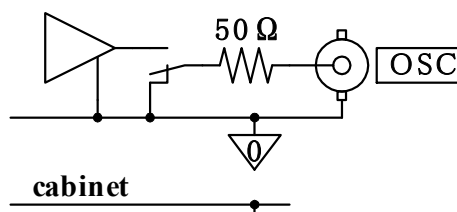

WARNING

- Do NOT connect to any measurement target that exceeds 250 Vrms of measurement Category I. Doing so may result in insulation breakdown, imposing electrical shock.
- You could be suffered from electric shocks when you measure high voltage circuit signals. Use accessory coaxial cables of the insulation type by all means, so that you cannot directly touch metallic portions of the BNC connectors at the analyzer input terminals.

The output impedance is always 50 Ω whether or not the output is “on”.

The maximum allowable output voltage is ± 10 V (for no load condition) for AC+DC, and the maximum allowable output current is ± 100 mA.

The load resistance to be connected at the maximum output shall be no less than 50 Ω.

The maximum output voltage to be set is ± 10 V (peak value) for AC+DC when a 50 Ω load is connected, where ± 5 V is applied for the 50 Ω load.

Set the output voltage with a condition of no load connected.

CAUTION

The internal circuit will be damaged if you apply external signal voltages to the output terminal. Never apply signal voltages to the output terminal.

[Notes]

- A signal transmitted on a 50 Ω series coaxial cable and the accompanying BNC cable (e.g., RG-58A/u, 3D-2V, etc.) gets approximately 5 ns per meter of time delay. This can be converted to the phase of 1.8 deg. per meter for 1 MHz.
- A 50 Ω series coaxial cable has approximately 100 pF per meter of electrostatic capacitance. If a signal is driven with a signal source resistance of 50 Ω, the signal will be affected so that it changes about -0.0043 dB in amplitude and -1.8 deg. in phase at 1 MHz.
- Pay attention to the cleanliness of the contact of the connector. Dirt/stains at the connector contact can cause approximately 0.03 dB of measurement errors depending upon measurement conditions.

± 24 V power supply output (AUX)

There is an electrical power supply outlet that supplies electrical power to the signal injector probe 5055 (separately sold).

This power outlet has the maximum current capacity of 100 mA. Connect to the outlet the cable that is attached to the signal injector probe 5055.

The figure below shows an example of the connection of the signal injector 5055 to the instrument.

For further information on operational methods of the 5055, refer to the 5055 Instruction Manual.

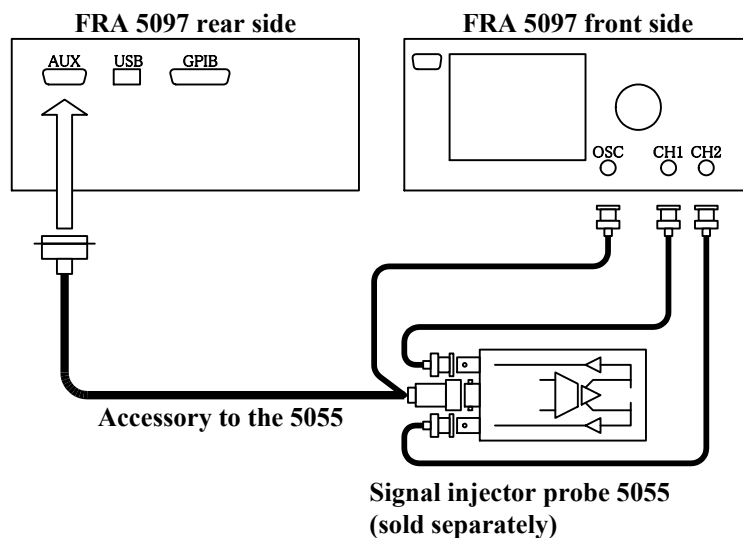

3.4 Insulation breakdown voltages of input and output voltages

The oscillator output terminal (OSC) and the analyzer input terminals (CH1 and CH2) individually are electrically insulated from the cabinet. The minimum dielectric breakdown voltage between the cabinet and the above mentioned parts of the FRA5097 is 250 Vrms. (CAT I) when the accompanying BNC cable is used, and 30 Vrms when another cable is used. Be careful not to apply voltages exceeding 250 Vrms between the cabinet and the individual polarities (i.e., signals and ground) of OSC, CH1 and CH2 terminals.

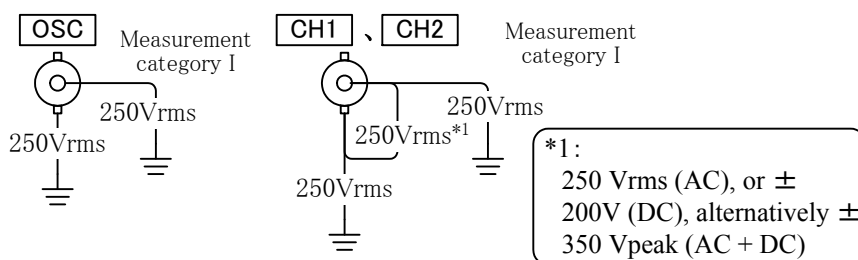

Fig. 3-1 From-enclosure isolation voltage specifications (when accompanying BNC cable is used)

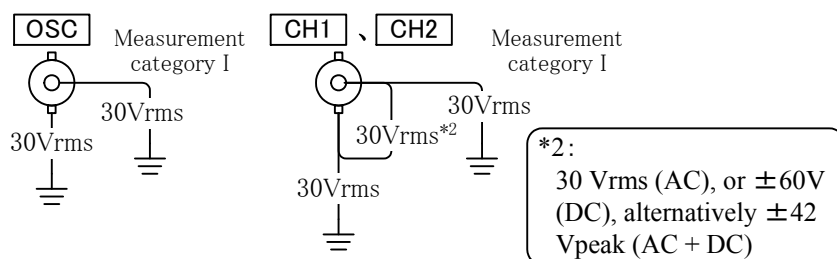

Fig. 3-2 From-enclosure isolation voltage specifications (when a cable other than the accompanying cable is used)

OSC, CH1 and CH2 are electrically insulated to each other. The minimum insulation breakdown voltage between the signal and the ground polarities for OSC, CH1 and CH2, individually, is 250 Vrms. (CAT_I) when the accompanying BNC cable is used, and 30 Vrms when another cable is used. The same minimum insulation breakdown voltage of 250 Vrms applies between signal polarities of OSC, CH1 and CH2.

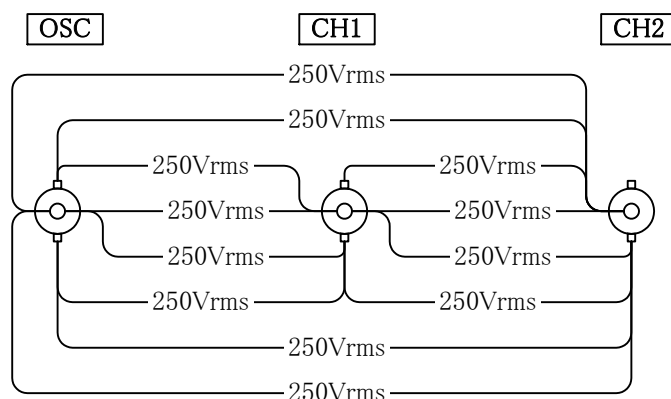

Fig. 3-3 Oscillation section-analysis section inputs isolation voltage specifications (when accompanying BNC cable is used)

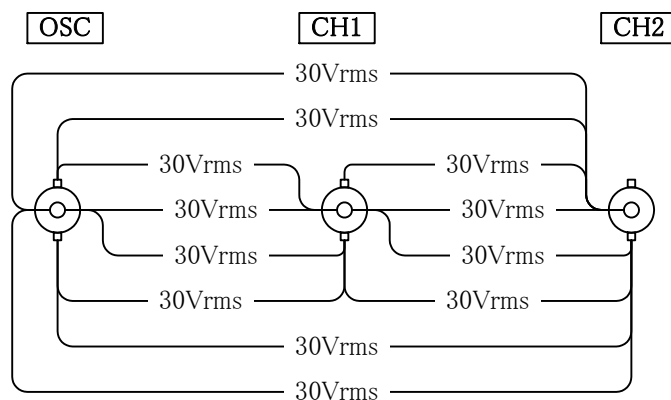

Fig. 3-4 Oscillation section-analysis section inputs isolation voltage specifications (when a cable other than the accompanying cable is used)

⚠ WARNING

- Do not apply excessive voltages between insulated signal terminals. You could be suffered from electric shocks, if excessive voltages are applied between these terminals leading to dielectric breakdown.
- You could be suffered from electric shocks when you measure high voltage circuit signals. Use accessory coaxial cables of the insulation type by all means, so that you cannot directly touch metallic portions of the BNC connectors at the analyzer input terminals.

3.5 Examples of basic operations

3.5.1 Menu operation

Much of the FRA5097 setting is in reference to menu operations shown on the LCD screen. The figure indicates the screen without menus as it appears immediately after startup.

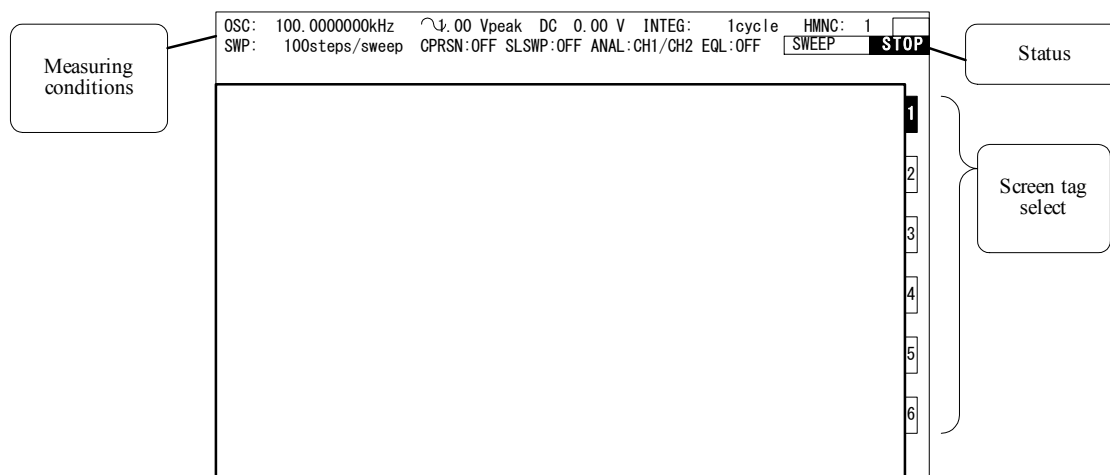



Fig. 3-5 Screen directly after start

■ Measuring conditions

The present main settings (measuring conditions) of the FRA5097 are shown. The abbreviations are defined as follows.



- OSC : Oscillator conditions are indicated. In sequence from the left are frequency, waveform, AC voltage and DC bias. When output is, AC voltage and DC bias are indicated as 0 V.
- INTEG : Number of integrations and integration time
- HMNC : Order of harmonics to be analyzed
- SWP : Sweep resolution
- CPRSN : Compression on/off
- SLSWP : Slow speed high density sweep on/off
- ANAL : Analysis mode
- EQL : Equalizing on/off

■ Screen tag selection and display

The FRA5097 has six (6) sets of screens, any one of which can be selected by the DISPLAY SCREEN   key. The selected screen is displayed by the blue color in this portion of the screen.

■ Status display portion

The status of the FRA5097 is displayed in the status display portion, e.g., “under measurement”, “GPIB remote status”, etc.

Right after the start-up, no menus are displayed on the screen as shown in “Fig. 3-5”. In this state, press either the MENU  or the  key to display the top menu on the screen. Then, press the  key to shift (or switch) the top menu from one to another. (See “Fig. 3-6 Top menu”)

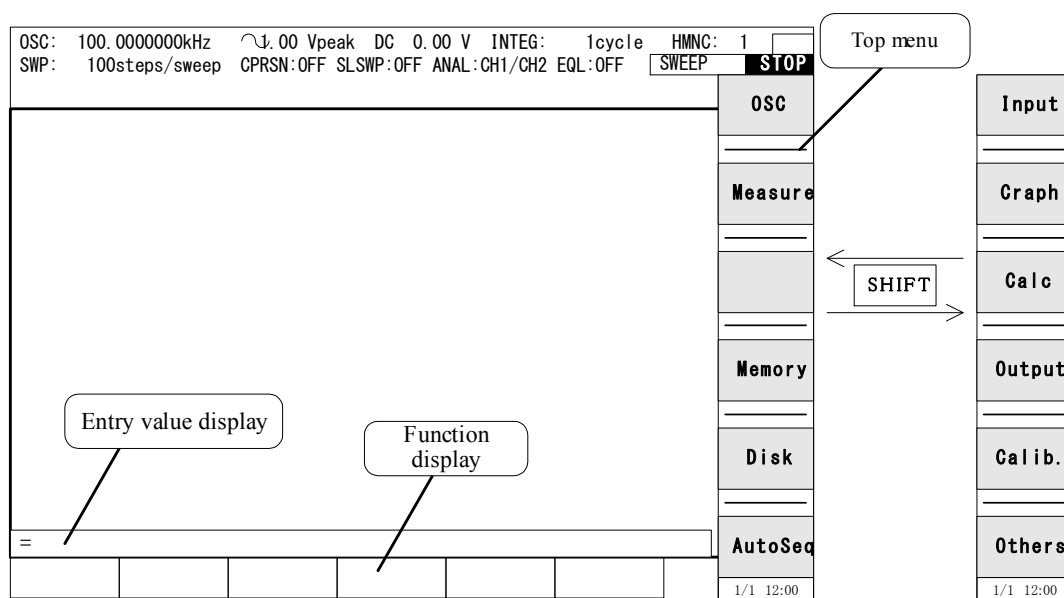





Fig. 3-6 Top menu

Press an appropriate key in the top menu to display the corresponding menu window at the upper left-hand side of the screen. Press the ITEM   key to select an item in the menu window. The selected item will be displayed in the inverse video. Press the MENU  key to select a lower level item. The next window in the lower level will be displayed. Press the MENU  key to return to the upper level menu window. (See “Fig. 3-7 Menu window”.)

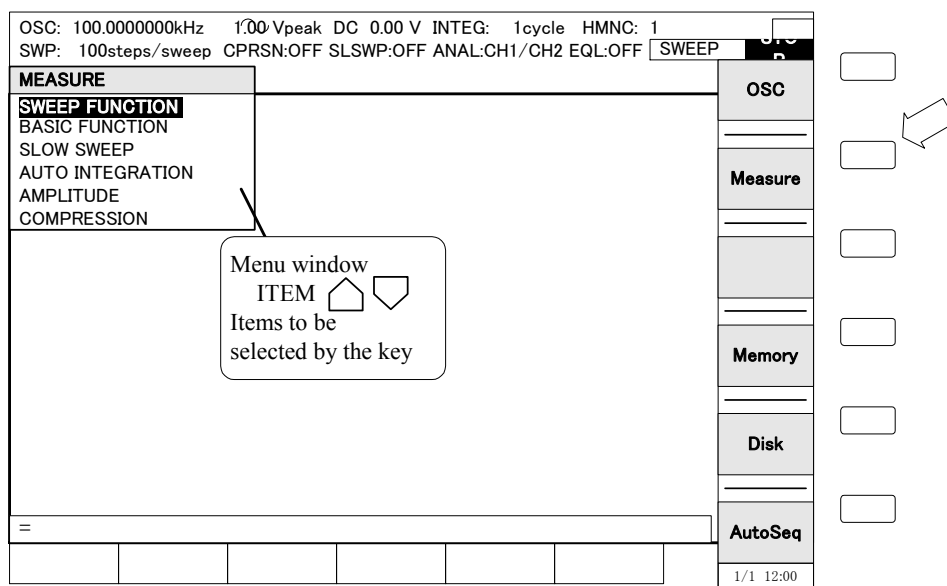
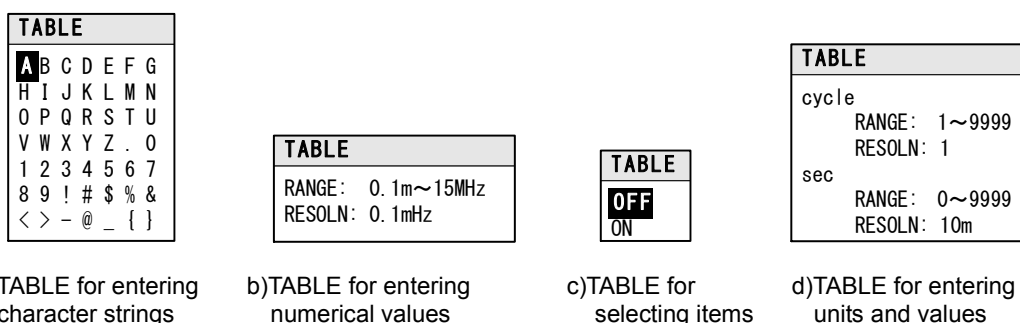

Fig. 3-7 Menu window









Continue on to press the MENU **OPEN** key to select menus one after another. TABLEs will be displayed which are to be used to select numerical values, character strings or other items. See the “**Fig.3-8 TABLE displays**” that are to be actually used for setting parameters, etc.



- a)TABLE for entering character strings
- b)TABLE for entering numerical values
- c)TABLE for selecting items
- d)TABLE for entering units and values

Fig. 3-8 TABLE displays

- Entering character strings: Press the ITEM key to select characters to enter.
Press the MENU **OPEN** key to display the selected characters in the entry value display portion at the bottom of the LCD screen and to shift the cursor in the same portion to the right by one (1) character. Repeat this process when you want to enter more than one character.
You can enter numerical values, **1** - **9** and **SP**, also from the ENTRY key.
After entering character strings as you wish, press the ENTRY **ENTER** key to fix them as the character strings.
- Entering numerical values: Press the ENTRY **1** - **9** **.** **-** and/or unit key to enter numerical values, and then press **ENTER** key to fix them.

- Selecting items: Press the ITEM   key to select items. The items will be set at the time of the selection.
- Entering units and items: Press the ITEM   key to select a unit and then press the  ~    and/or unit key to enter numerical values. Press the  key to fix them.

When you are entering character strings and numerical values, you can delete the most recently entered character and put the cursor back by one (1) character through pressing the ENTRY  (Back Space) key. The cursor flashes black at the entry location as indicated in Fig. 3-9.

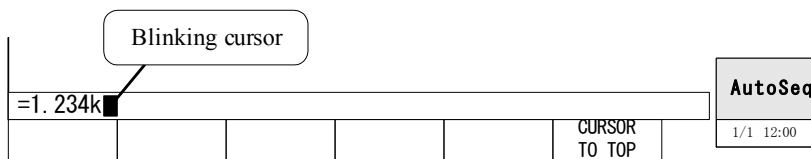

Fig. 3-9 Display during entering figures

When a menu window is displayed on the screen, a series of functions corresponding to the displayed menu is displayed in the function display portion at the bottom of the LCD screen. Press a key you want under the function display portion to display the wanted function. (See “Fig.3-10 Function Display”.)

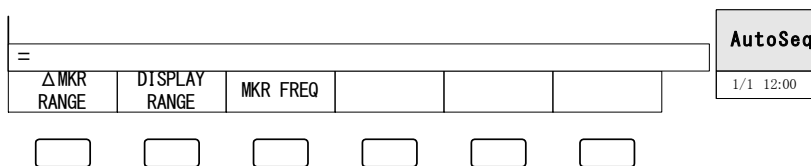

Fig. 3-10 Function Display

3.5.2 On/off operations for oscillator output

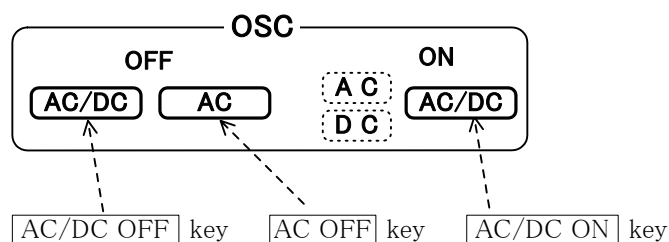

Fig. 3-11 Oscillator control key

- Oscillator output “on”: Press the **AC/DC ON** key to switch on the oscillator output and to turn on the AC and DC lamps adjacent to the key. At this time, the actual oscillator output voltage level is also displayed in the measurement condition display portion of the LCD display screen. Note that the actual oscillator output level will not change until this key has been pressed, even if you change the AC amplitude or DC bias setting.
- Oscillator output “off”: Press the **AC/DC OFF** key to turn off the AC and DC lamps and to turn the display into 0 V for both the AC amplitude and DC bias in the measurement condition display portion on the LCD display screen.
- AC component “off”: Press the **AC OFF** key to turn off the AC lamp only and to turn the display into 0 V for the AC amplitude only in the measurement condition display portion on the LCD display screen. The DC bias output is still on with its value unchanged.

⚠ CAUTION

The output voltage will not change even if you change the output voltage setting, unless you press the **AC/DC ON** key.

For more details, refer to “4.5 Oscillator setting”.

3.5.3 Examples of basic measurement operations

This section describes setting procedures for basic measurement operations. The descriptions assume that the setting status of the FRA5097 is the same as that at delivery from factory or that right after initialization.

a) Example of SINGLE measurement

The SINGLE measurement is a measurement mode where only one time of measurement is made at a fixed frequency. An example of measurement is described below with the following measurement conditions:

- Measurement frequency : 1.0 MHz
- Oscillator : Amplitude=5 V_{peak} and DC bias=1 V (the amplitude to be set with the output being open)

The following parameters are unchanged from those at completion of initialization:

- Oscillation waveform : sinusoidal
- Number of times of integration : 1 cycle
- Delay time : 0 second
- Measurement mode : CH1 and CH2
- Analysis mode : CH1/CH2
- Display mode : X-axis : logF
Y1-axis : dBR
Y2-axis : θ

1) Connection with the SUT (system under test)

Since the measuring mode is CH1 and CH2, connect the FRA5097 and the system under test (SUT) as shown in Fig. 3-12.

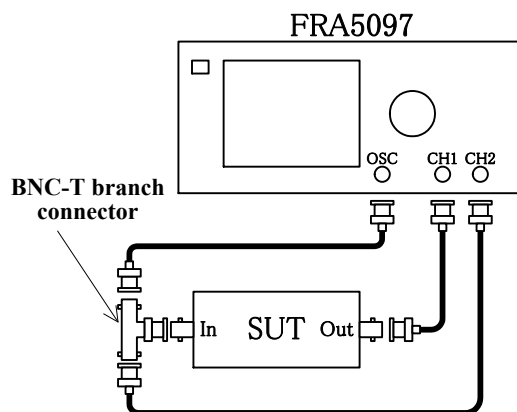

Fig. 3-12 Connection with SUT

2) **Setting FRA5097**

Press the following keys in the following order:

- Setting measurement frequency (at 1.0 MHz):

OPEN **OSC** (menu selection key) **CURSOR TO TOP** (function key)

OPEN **1** **M** **ENTER**

- Setting AC amplitude (at 5 V_{peak})

ITEM  **OPEN** **5** **ENTER**

- Setting DC bias (at +1 V)

ITEM  **OPEN** **1** **ENTER**

- Deleting menu

CLEAR

- Setting oscillator output “on”

AC/DC ON

3) **SINGLE measurement** ... Press the **MEAS** key to perform measurement.

At the end of measurement, the resulting data are shown at the center of the LCD, as indicated in Fig. 3-13.

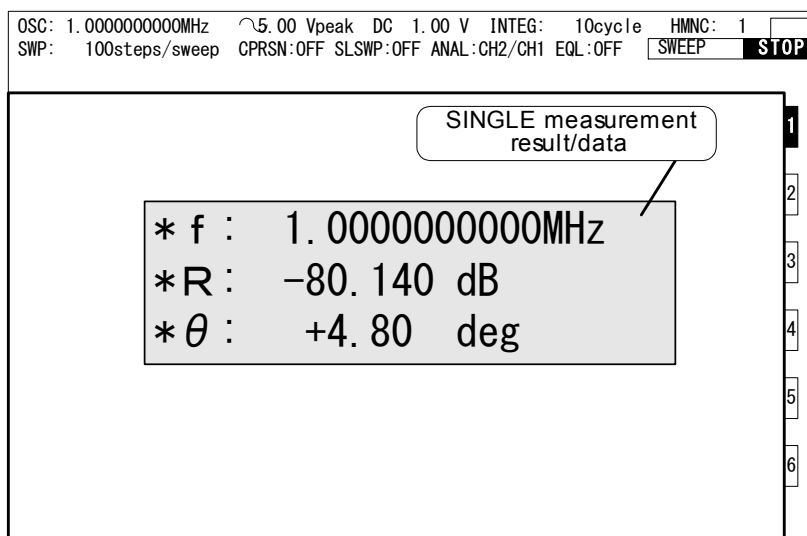

Fig. 3-13 SINGLE measurement result

b) Example of REPEAT measurement

Repeat the SINGLE measurement (measurement at a fixed frequency). Press the **REPEAT** key to turn on the REPEAT lamp, and then press the **MEAS** key to obtain the measurement data.

The measurement data are displayed in the center of the LCD screen as is the case for the SINGLE measurement. The measurement data display is updated at every time when one time of measurement is completed.

c) Example of Sweep measurement

The Sweep measurement is a measurement mode where measurement is made through frequency sweep. An example of measurement is described below with the following measurement conditions:

- Measurement frequency : 1.0 kHz - 2.2 MHz
- Oscillator : Amplitude=7 Vpeak
- Number of times of integration : 10 cycle

The following parameters are unchanged from those at completion of initialization:

- Sweep resolution : LOG 100 steps/sweep
- Oscillation waveform : sinusoidal
- Delay time : 0 second
- Measurement mode : CH1 and CH2
- Analysis mode : CH1/CH2
- Display mode : X-axis : logF
Y1-axis : dBR
Y2-axis : θ

1) Connection with the SUT (system under test)

Connect the FRA5097 with the SUT (system under test) according to “**Fig. 3-12 Connection with SUT**” for the measurement mode of (CH1 and CH2).

2) Setting FRA5097

Execute the key entries by the following sequence. Using the **BASIC SETUP** key facilitates the important item settings, and allows you to observe the current setting condition at a glance.

- Sweep maximum frequency setting (2.2 MHz)

BASIC SETUP **CURSOR TO TOP** (function keys)

OPEN **2** **.** **2** **M** **ENTER**

- Sweep minimum frequency setting (1 kHz)

ITEM **OPEN** **1** **k** **ENTER**

- AC amplitude setting (7 V_{peak})

ITEM **OPEN** **7** **ENTER**

- Integration cycle setting (10 cycles)

ITEM **OPEN** **1** **0** **ENTER**

- Deleting menu

CLEAR

- Setting oscillator output “on”

AC/DC ON

3) Sweep measurement ... Press either the **SWEEP UP** key or the **DOWN** key.

When you start measurement, the measurement data start to come out gradually as a graph on the display.

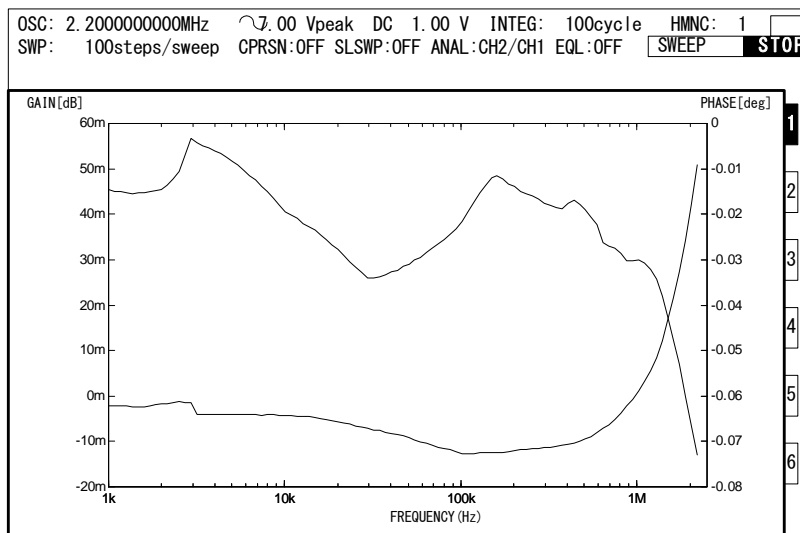

3.5.4 Examples of connections

Typical examples of measurement connections are described in this section. In actual measurement, be careful about the influence on the SUT of the common- and differential-mode impedance of the oscillator output and analyzer input in the FRA5097.

■ Frequency characteristics measurement of amplifiers (1)

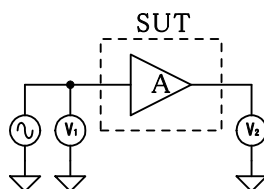

Fig. 3-14 Connection diagram for frequency characteristics measurement (1)

Connect V_1 with CH1 and V_2 with CH2, respectively.

The frequency transfer function of the SUT (system under test) can be obtained from the following equation:

$$A = \frac{\dot{V}_2}{\dot{V}_1}$$

Set the measurement mode at (CH1 and CH2) and the analysis mode at (CH2/CH1) for the FRA5097, to display the SUT frequency characteristics (gain and phase versus frequency) on the LCD screen so that you can directly read them through the display.

■ Frequency characteristics measurement of amplifiers (2)

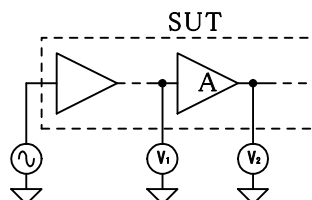

Fig. 3-15 Connection diagram for frequency characteristics measurement (2)

The diagram above shows the connection for measurement of the transfer function of A (only for A) in the SUT.

The transfer function of A can be obtained from the following equation:

$$A = \frac{\dot{V}_2}{\dot{V}_1}$$

Set the analysis mode at (CH2/CH1) for the FRA5097 to display the frequency characteristics (gain and phase versus frequency) of A on the LCD screen so that you can directly read them through the display.

■ Servo loop characteristics measurement

The servo loop is composed of an amplifier A with high gain and a feedback circuit β . It is required that you fully understand the characteristics of the amplifier A itself so that you get improved performance characteristics (e.g., response time, steady-state error characteristic, etc.) for the servo loop.

The frequency characteristics of amplifiers with feedback circuits incorporated (i.e., closed loop characteristics :Tc) can relatively easily be measured through the use of a method of “Fig. 3-14 Connection diagram for frequency characteristics measurement (1)”. It is generally difficult to directly measure the open loop characteristics To of A exclusively or of $A\beta$, due to, e.g., easy saturation of the amplifier A even with very low input signals. Note that it is required to open the feedback loop to measure the characteristics of the amplifier A or the open loop $A\beta$.

The FRA5097 can be used to measure of the servo loop; i.e., The oscillator of the FRA5097 is to be inserted into the servo loop circuit. The measurement is made possible by virtue of such FRA5097’s features as its wide dynamic range as well as its oscillator output and analyzer inputs being electrically floated from the cabinet. The oscillator output level is set so low compared with the signal level of the SUT that the effect of the measurement signal upon the SUT can be maintained minimal or negligible.

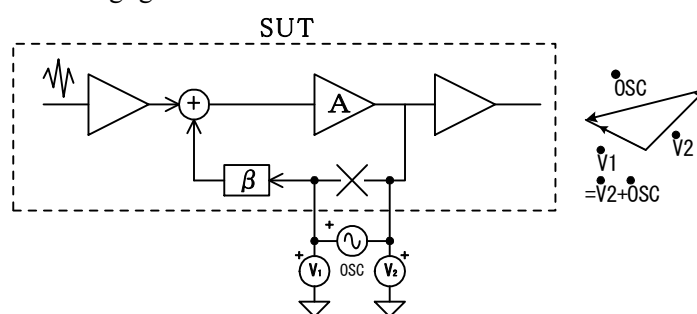

Fig. 3-16 Connection diagram for loop gain measurement

The open loop gain A

$$A\beta = \frac{\dot{V}_2}{\dot{V}_1}$$

Set the analysis mode at (CH2/CH1) for the FRA5097 to display the loop gain frequency characteristics on the LCD screen so that you can directly read them through the display.

The characteristics of the feedback circuit β can be measured through various methods, e.g., “Fig. 3-15 Connection diagram for frequency characteristics measurement (2)”. You can also obtain the characteristics of the amplifier A exclusively through dividing the open loop characteristics $A\beta$ by β . You can calculate $A\beta \div \beta$ by using the calculation function of the FRA5097.

■ Impedance measurement

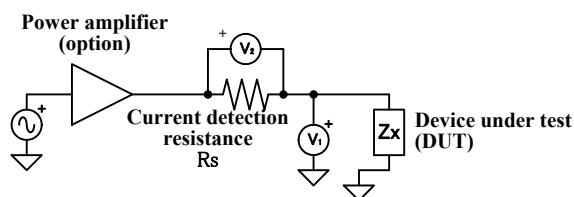

Fig. 3-17 Connection diagram for impedance measurement

The current flowing through the DUT (device under test) can be measured as the voltage V_2 that is detected by the current detection resistance R_s , and the voltage across the DUT can be measured as V_1 as shown in the figure.

The DUT impedance Z_x is obtained by the following equation:

$$Z_x = \frac{\dot{v}}{\dot{i}} = \frac{\dot{V}_1}{\dot{V}_2 / R_s} = \frac{R_s \dot{V}_1}{\dot{V}_2}$$

Set the display unit to impedance, the analysis mode at (CH1/CH2) for the FRA5097, and also, the CH2 input weighting factor at $1/R_s$ (for $1.0\Omega < R_s$) to measure the DUT impedance characteristics and to display them as the amplification gain on the LCD screen. Open correction and short correction allow measurement by correcting the error factors of the measurement system, which includes cables and shunt resistance.

Refer to “5. Impedance display function”.

3.5.5 High frequency measurement

At frequencies above 1 MHz, measurement error increases with greater frequency. Following are points to be considered when measuring high frequencies.

a) Measuring mode

Since error increases in measuring modes (CH1, OSC) and (OSC, CH2), use (CH1, CH2). The increase is due to the different signal paths of these modes.

b) Analysis mode

When measuring signal voltage in analysis mode CH1 or CH2, error increases at frequency exceeding about 2 MHz.

c) Auto ranging

The FRA5097 internal measuring range automatically corresponds to the signal size. Since calibration error increases at high frequency, the measurement graph may show small steps before and after range selection.

d) Use correct probe

At high frequency, electrostatic capacitance of the cable greatly affects the system under test (SUT). Also, signal reflection due to impedance mismatch can increase measurement error. In these type situations, the use of a suitable probe to reduce measurement error is recommended.

For example, a 10:1 oscilloscope probe can be used. Select a probe with an oscilloscope matching impedance in the range of 20 to 30 pF at 1 M Ω . Before measuring, adjust the probe trimmer for flat frequency response.

While using the probe to measure an oscillator output, adjust the trimmer to where the voltage (or ratio) at 100 kHz is equal to the voltage (or ratio) at 10 Hz. Use Repeat measurement and first measure the voltage (or ratio) at 10 Hz.

According to the probe type and the trimmer initial setting, a lower reference frequency is desirable.

By using a 10:1 probe, the signal is attenuated 1/10. But this can be largely compensated by using a weighting factor 10 at the analyzer input.

By using a 10:1 probe, the signal is attenuated 1/10. But this can be largely compensated by using a weighting factor 10 at the analyzer input.

See 4.4 Input setting [Weighting factor].

The FRA5097 equalizer function can be used to compensate the probe error correction.

See 4.7 Equalization

By applying a feed through type 50 Ω terminator to the FRA5097 signal input terminal, a 500 Ω input impedance high frequency 10:1 probe can also be used.

 **WARNING**

- Do not float the probe reference lead to 30 Vrms more than. To avoid electric shock or failure when using probes with exposed metal parts, do not connect the reference lead to voltages above 30 Vrms.
 - In addition, the electric strength between signal terminals is dependent on the probe used. For details, please confirm probe specification.
-

e) Connecting cable length and routing

The FRA5097 signal line and chassis are isolated. However, at high frequency, current can easily flow between the cable outer conductor (shield) and ground due to stray capacitance. If the connecting cable is long, oscillation can occur due to such properties as cable inductance and isolation capacitance, disturbing frequency response and possibly preventing measurement.

In this type of case, such measures as shortening the cable or twisting the cables, inserting a common mode choke in the cable can provide improvement. For example, a clamp type ferrite core, such as used for correcting noise, can be attached to the cable.

Cable routing and coupling between cables can change the impedance to ground and thus appear like a variation in characteristics. In this type of case, minimizing cable junctions and securing the cable location can improve measurement consistency.

4. Examples of application operations

4.1	Overview of measurement and processing	4-2
4.2	Delaying measurement start.....	4-7
4.3	Integration.....	4-8
4.4	Input setting	4-10
4.5	Oscillator setting.....	4-11
4.6	Display setting	4-14
4.7	Equalization	4-22
4.8	Harmonics analysis.....	4-24
4.9	Amplitude compression	4-25
4.10	Frequency axis high density slow sweep.....	4-27
4.11	Calculation functions	4-28
4.12	Auto-sequence	4-32
4.13	Simplified load/save of setting conditions	4-35
4.14	Output to printer	4-37
4.15	Output to USB flash drive	4-40
4.16	Calibration	4-41
4.17	File operation	4-42
4.18	Memory	4-45
4.19	Condition display.....	4-46
4.20	Max/min search function	4-46
4.21	Other functions	4-47

4.1 Overview of measurement and processing

This section describes the flow of data processing from measurement up to data display in the FRA5097. (See “**Fig. 4-1 Flow diagram of measurement and processing**”.)

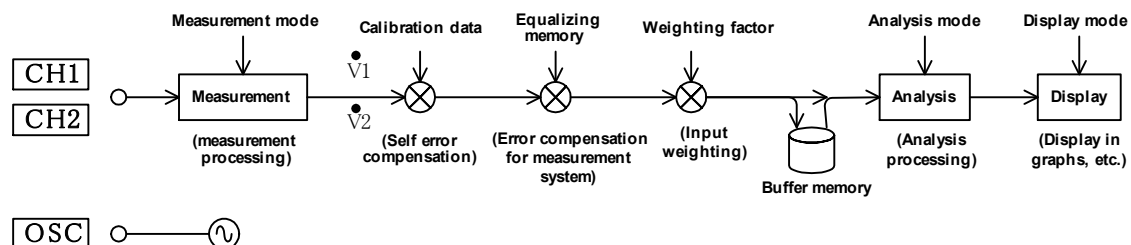

Fig. 4-1 Flow diagram of measurement and processing

- **Measurement processing:** This phase determines the connection of input terminals and of the internal circuit. The measurement is done through DFT (discrete Fourier transform).
- **Self error compensation:** Self error compensation is made through the use of calibration data obtained by calibration. Calibration can be done either at the time of switching power supply on, or through the menu [Calib.].
- **Error compensation for measurement system:**
The characteristics of various measurement equipment connected externally to the FRA5097 are measured as measurement system errors. The errors can be canceled at actual measurement (through the equalizing capability).
- **Input weighting:** The measurement data of CH1 and CH2, individually, can be weighed by arbitrary individual factors of the range between 0 and 1.0E+6 through the menu [Input][WEIGHTING FACTOR].
- **Buffer memory:** The measured and error compensated data are stored in the temporary buffer memory.
- **Analysis processing:** Analysis is made in the measurement process of measurement through error compensation phases, and the original measurement data are converted to the data to be displayed.
- **Display processing:** The analyzed data are displayed in the form of graphs on the LCD screen according to the display format that has been set.

Data obtained in the sweep-mode measurement are once stored in the buffer memory while data analysis and display are also being done. The data read out from the buffer memory can be used for analysis and display format conversion without remeasurement.

4.1.1 Measurement mode

There are three (3) measurement modes available, i.e., (CH1, CH2), (CH1, OSC) and (OSC, CH2), one of which is selected for the measurement. The measurement mode is set through the menu [Measure][BASIC FUNCTION][MEASURE MODE].

Note: The measurement mode (CH1, CH2), for example, is sometimes expressed as (CH1 and CH2) in this Instruction Manual.

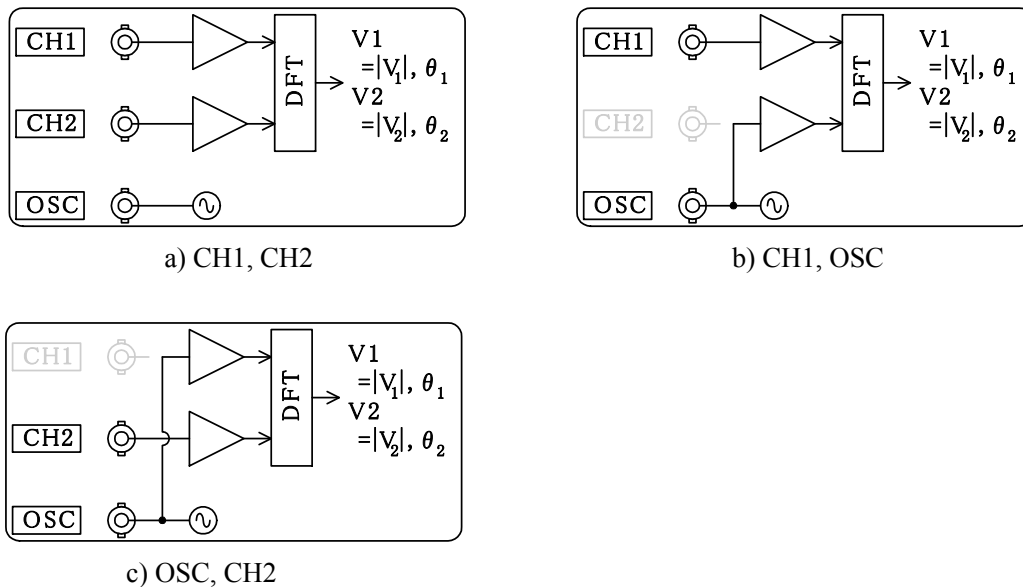

Fig. 4-2 Measurement mode and internal connection

The measurement mode (CH1, CH2) is used for the three-port system and the measurement modes (CH1, OSC) and (OSC, CH2) are used for the two-port system. Note, however, that the two-port system measurement provides better results for the measurement mode (CH1, CH2), since the effect of cables can be reduced in the two-port system measurement.

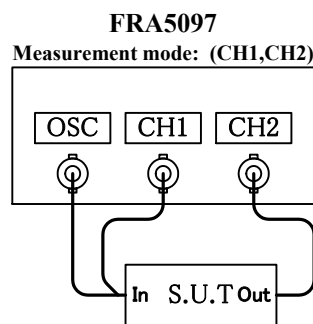

Fig. 4-3 Recommended measurement connection for two-port system

4.1.2 Analysis mode

The analysis mode specifies the method in which the measurement data (V_1 , V_2 and θ) are to be analyzed and processed. There are four (4) analysis modes, i.e., (CH1/CH2), (CH2/CH1), (CH1) and (CH2), one of which should be set through the menu [Graph][FORMAT][ANALYSIS MODE].

The result of analysis is given by the gain and phase for the analysis modes, (CH1/CH2) and (CH2/CH1), and by voltage amplitude and phase for the analysis modes, (CH1) and (CH2).

Table 4-1 List of analysis modes

Measurement mode	Analysis mode	Result of analysis
$ V_1 , \theta_1$ $ V_2 , \theta_2$	(CH1/CH2)	Gain = $ V_1 / V_2 $
		$\theta = \theta_1 - \theta_2$
	(CH2/CH1)	Gain = $ V_2 / V_1 $
		$\theta = \theta_2 - \theta_1$
	(CH1)	Amplitude = $ V_1 $
		$\theta = \theta_1 - \theta_2$
	(CH2)	Amplitude = $ V_2 $
		$\theta = \theta_2 - \theta_1$

4.1.3 Graph units setting

The display units setting is selected for gain and impedance.

The graph display units are determined by [UNITS] and [ANALYSIS MODE] setting. Display units are indicated in Table4-2.

Impedance display is fixed at voltage for CH1 input and current for CH2 input.

Table 4-2 Display units

ANALYSIS	GAIN	IMPEDANCE
CH1	GAIN[Vrms] GAIN[dBV]*1	GAIN[Vrms] GAIN[dBV]*1
CH2	GAIN[Vrms] GAIN[dBV]*1	GAIN[Arms] GAIN[dBA]*2
CH1/CH2	GAIN[E+00] GAIN[dB]	IMPD[Ω] IMPD[dB Ω]*3
CH2/CH1	GAIN[E+00] GAIN[dB]	ADMT[S] ADMT[dBS]*4

Notes

1. 1 Vrms = 0 dBV
2. 1 Arms = 0 dBA
3. 1 Ω = 0 dB Ω
4. 1 S = 0 dBS

4.1.4 Display mode

In the display mode setting, representation methods of graphic display for analyzed data on the LCD screen, i.e., gain (or amplitude) vs. phase, are specified/set.

The display mode is set through the menu [Graph][FORMAT][DISPLAY MODE]. The data displayed in the graph depend on the analysis mode and display units setting.

The following explains the display mode when the display unit is set to GAIN. For the display mode when the display unit is set to IMPEDANCE, see 5. Impedance display function.

Combinations other than those shown in Table 4-3 List of display modes are invalid. When an invalid combination is specified, no graph is displayed, or the previously shown graph is deleted. Since the data is retained in this case, a graph is displayed when a valid combination is specified.

Table 4-3 List of display modes (1) for analysis mode: (CH1) or (CH2)

[DISPLAY MODE]			Display Item			Remark
X axis	Y1 axis	Y2 axis	X axis	Y1 axis	Y2 axis	
$\log F$ F	dBR logR R	θ —	Frequency	Amplitude	Phase/none	Bode chart
$\log F$ F	θ	—	Frequency	Phase		
$\log F$ F	logA log(-A)	logB log(-B)	Frequency	Real amplitude	Imaginary amplitude	
$\log F$ F	A	B	Frequency	Real amplitude	Imaginary amplitude	
θ	dBR logR R	—	Phase	Amplitude		Nichols chart
A	B	—	Real amplitude	Imaginary amplitude		Nyquist diagram
A	-B	—	Real amplitude	Negative imaginary amplitude		Cole cole plot

Table 4-3 List of display modes (2) for analysis mode: (CH1/CH2) or (CH2/CH1)

[DISPLAY MODE]			Display Item			Remark
X axis	Y1 axis	Y2 axis	X axis	Y1 axis	Y2 axis	
$\log F$ F	dBR logR R	θ —	Frequency	Gain	Phase/none	Bode chart
$\log F$ F	θ	—	Frequency	Phase		
$\log F$ F	logA log(-A)	logB log(-B)	Frequency	Real gain	Imaginary gain	
$\log F$ F	A	B	Frequency	Real gain	Imaginary gain	
θ	dBR logR R	—	Phase	Gain		Nichols chart
A	B	—	Real gain	Imaginary gain		Nyquist diagram
A	-B	—	Real gain	Negative imaginary gain		Cole cole plot

The following table indicates the X-axis, Y1-axis, and Y2-axis contents and units that are set under the [DISPLAY MODE].

Table 4-4 Graph axis contents

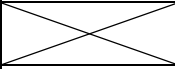
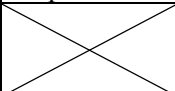
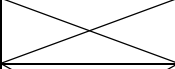
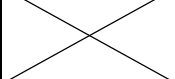
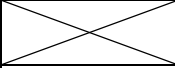
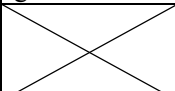
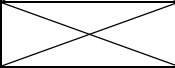
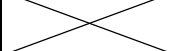
Axis Setting	Axis Setting	Axis Content	Scale	Unit
CH1/CH2, CH2/CH1, CH1,CH2	logF	Frequency	Log	Hz
	F	Frequency	Linear	Hz
	θ	Phase	Linear	deg
CH1,CH2	dBR	Amplitude	Linear	dBV ^{*1}
	logR	Amplitude	Log	Vrms
	R	Amplitude	Linear	Vrms
	logA	Real amplitude	Log	Vrms
	log(-A)	Negative real amplitude	Log	Vrms
	A	Real amplitude	Linear	Vrms
	logB	Imaginary amplitude	Log	Vrms
	log(-B)	Negative imaginary amplitude	Log	Vrms
	B	Imaginary amplitude	Linear	Vrms
	-B	Negative imaginary amplitude	Linear	Vrms
CH1/CH2, CH2/CH1	dBR	Gain	Linear	dB
	logR	Gain	Log	None
	R	Gain	Linear	None
	logA	Real gain	Log	None
	log(-A)	Negative real gain	Log	None
	A	Real gain	Linear	None
	logB	Imaginary gain	Log	None
	log(-B)	Negative imaginary gain	Log	None
	B	Imaginary gain	Linear	None
	-B	Negative imaginary gain	Linear	None

*1 : 1 Vrms is assumed to be 0 dBV.

4.2 Delaying measurement start

When the oscillator frequency changes in the frequency sweep mode, the measurement data may, in general, have errors due to transient response if the SUT (system under test) involves any response time delay components. The measurement start time is set with some delay time period for the FRA5097 frequency response characteristics measurement, so that the transient error can be suppressed at the minimum level. You can set the delay time period at an arbitrary value according to the time constant of the SUT.

Among others, note that sufficient period of time delay needs to be secured for measuring accurately the SUTs that involve high order elements (e.g., filters with steep frequency characteristics, high Q resonance circuits with crystal oscillators, etc.), since they have a long period of time delay.

Use the menu [Measure][BASIC FUNCTION][DELAY TIME] to set the period of time delay. The period of time delay can be set with respect to either the number of cycles of analysis frequency (unit: cycle) or the time period (unit: second).

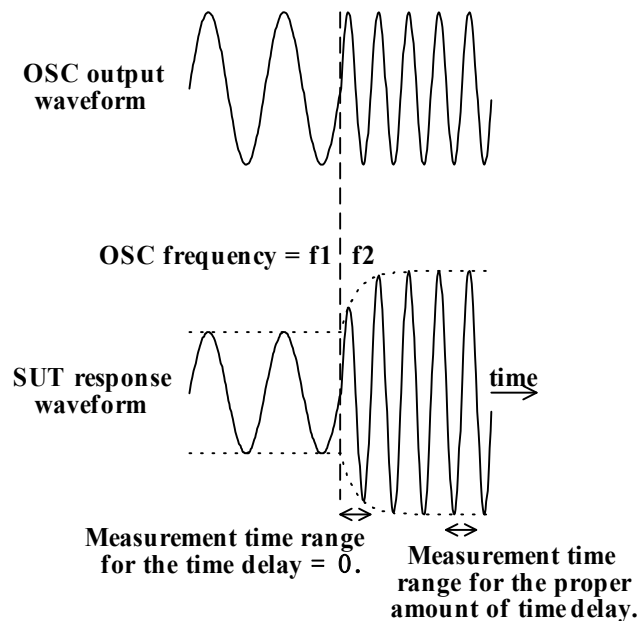

Fig. 4-4 Response waveform requiring measurement start time delay

4.3 Integration

The methodology of the FRA5097 measurement uses Fourier integral operation of waveforms to be measured for each cycle (or one (1) time period) so that noise and harmonics components will essentially be excluded from the measurement result. The accuracy of measurement can be augmented by increasing the number of integrations (note: the integral for the period of one cycle counts as one time of integration), especially when signal levels are low compared with noise levels or when the high accuracy measurement is required.

The number of integrations (or the integration time period) that is set for the FRA5097 measurement corresponds to averaging operation of input signal waveforms before Fourier integration. The Fourier integral operation by its nature suppresses harmonics component by more than 60 dB, irrespective of the number of times of Fourier integrations.

White noise component is suppressed by Fourier integration by the amount approximately proportional to the square root of the number of Fourier integrations. Noise components outside of analysis frequencies are also suppressed by increasing the number of Fourier integrations. Therefore, the larger the number of Fourier integrations, the higher the accuracy of measurement. The time required for measurement is, needless to say, proportional to the number of times of Fourier integrations.

The FRA5097 has two (2) ways of integration operation methods available: manual integration and automatic integration.

a) Manual integration

Measurement is done at each analysis frequency in the sweep frequency range for the number of times of Fourier integrations (or the integration time period) that has been preset. The number of integrations is set by the menu [Measure][BASIC FUNCTION][INTEGRATION TIME]. The unit to be used for setting this integration parameter is either time duration (e.g., ms) or period (cycle). When you set the parameter by time duration, this will be converted into the number of cycles within the instrument.

The time period required for one time of integration depends upon the analysis frequency f ; approximate time period required for one time of integration is shown in the following for each analysis frequency range:

- $f \leq 54$ Hz (approx.) : Time period (duration) of one (1) cycle
- 54 Hz (approx.) < f < 3 kHz : In the range of 18.2 ms to 54.6 ms
- 3 kHz $\leq f$: 18.2 ms (approx.)

“Fig. 4-5 Effect of integration” illustrates an example of effect of the number of times of integrations by comparing the numbers 100 versus 1. The figure shows that the noise suppression effect is approximately 10 (20 dB), which is the square root of 100.

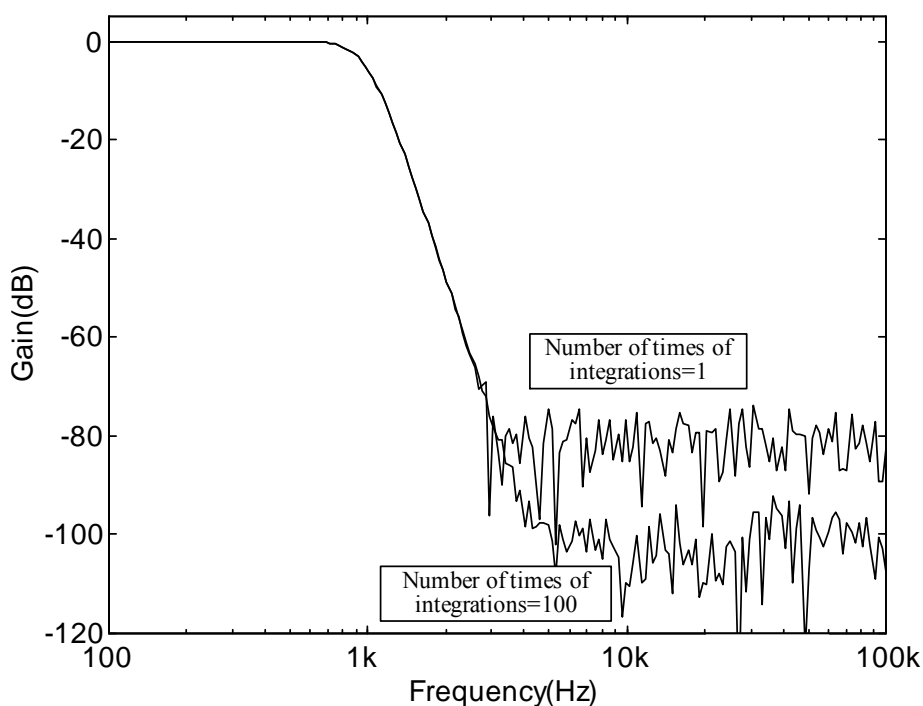

Fig. 4-5 Effect of integration

b) Automatic integration

Assume that the SN ratio is poor only for the limited frequency range within the range of frequency sweep, and also assume that the number of times of integrations has been set manually so that satisfactory measurement accuracy can be obtained in this limited frequency range, then it comes that the required measurement time is excessively long in that integration operations that are not necessary in the other part of the frequency range should also be done.

The FRA5097 has a special capability called automatic (auto) integration which provides a capability of automatically setting integration times during the measurement. The use of automatic integration capability will lead to automatic selection of optimum integration times as well as reduction of the measurement period of time. Set [FUNCTION]“ON” in the menu [Measure][AUTO INTEGRATION] to perform automatic integration. Set the analysis channel, which is to be referred to for determining the integration count, to be focused, by [COHERENCE MODE] of the [Measure][BASIC FUNCTION] menu. Select the coherence estimated value (variance estimated value) of measurement data to be at “SHORT”(0.9) or ”LONG”(0.99) in [MODE], and then repeat integration operations until the set value is satisfied. Note, however, that the integration at a certain frequency will terminate when the number of times of integration reaches the value set in [MAX INTEGRATION TIME].

The coherence estimated value (coh^2) expresses a statistical cross characteristic between two (2) varying signals and corresponds to the square of the cross correlation coefficients of individual Foulter frequency components of the two signals. It is generally judged that measurement data are more reliable when the coherence estimated value is closer to 1.0. (The closer the chop to 1.0, the more reliable the measurement data.)

4.4 Input setting

The input setting involves settings of excessive input level (OVER) detection and of input channel weighting for analysis input channels, CH1 and CH2. The menu [Input] is used for the setting.

[OVER]

[CH1 LEVEL], [CH2 LEVEL]

These are to set the detection levels for excessive (over) input signal levels. The FRA5097 has the capability of measuring up to 250 Vrms of input signals due to the auto-range capability of the analysis inputs. However, any levels that exceed the levels set here are judged to be excessive (over) input signal levels.

Note, however, that the excessive level setting is nothing to do with the weighting factor setting in [WEIGHTING FACTOR] below.

[ACTION]

[BUZZER], [SWEEP STOP], [OSC OFF]

These are to be used to set actions when excessive (over) levels were detected.

Each of the above indicates “to activate buzzer”, “to stop frequency sweep” or “to turn off only AC component of oscillator as well as to stop frequency sweep (DC bias output is alive)”, respectively.

[WEIGHTING FACTOR]

[CH1], [CH2], [INVERT]

Weighting is to be applied for CH1 and CH2, respectively, within the range of 0 up to $1.0E+6$. Resolution is 5 digits or $0.1E-9$. For example, if 0.9 has been set for the weighting factor and 1 V is input, the input signal level is interpreted as 0.9 V. By setting Invert On, the phase can be inverted (rotated $+180^\circ$) for measurement.

Note that the weighting factor that is set here does not affect the excessive detection level mentioned above.

The over detect level and weighting factor relationship is indicated in Fig. 4-6.

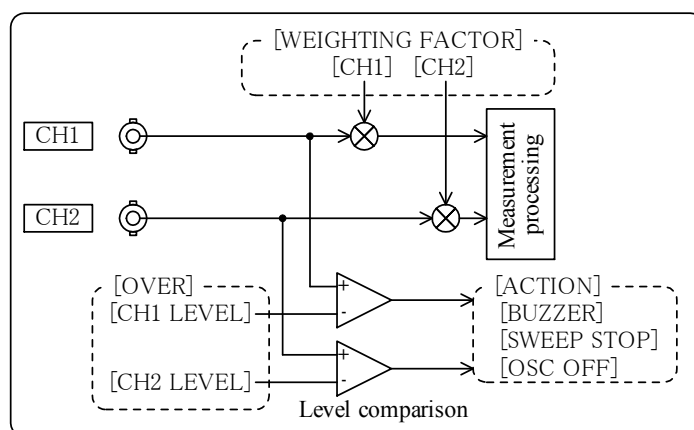

Fig. 4-6 Principle of excessive level detection

4.5 Oscillator setting

4.5.1 Oscillator basic setting

Use the menu [OSC] to set the parameters, states, etc. pertaining to the oscillator.

[FREQUENCY]

This is used to set the oscillator frequency. This is primarily used for measurements at fixed frequencies (SINGLE measurement or REPEAT measurement).

[AMPLITUDE], [DC BIAS]

These are used to set the AC output voltage amplitude (Amplitude) and the DC output voltage (DC Bias) of the oscillator. Press the **AC/DC ON** key by all means, even if the AC and DC lamps are lit on at the time of setting operation.

CAUTION

The output voltage will not change even if you change the output voltage settings, unless you press the **AC/DC ON** key.

[STOP MODE]

One of the following is selected in the oscillator stop mode, when you press the **AC OFF** key:

- [ZERO] : The oscillator stops with the AC output voltage becoming 0 V at the instant of your pressing the key.
- [HOLD] : The oscillator stops with the AC output phase being maintained at the instant of your pressing the key.
- [PHASE] : The oscillator stops at the time when the output phase becomes the same as that set by [START/STOP PHASE] through time elapse.

Regardless of the setting mentioned above, the output voltage becomes 0 V when the **AC/DC OFF** key is pressed.

The oscillator output voltages are shown in the figure as “**Fig. 4-7 Oscillator stop mode**”, in which the **AC OFF** key is pressed first while the oscillator output is on, then the **AC/DC ON** key is pressed.

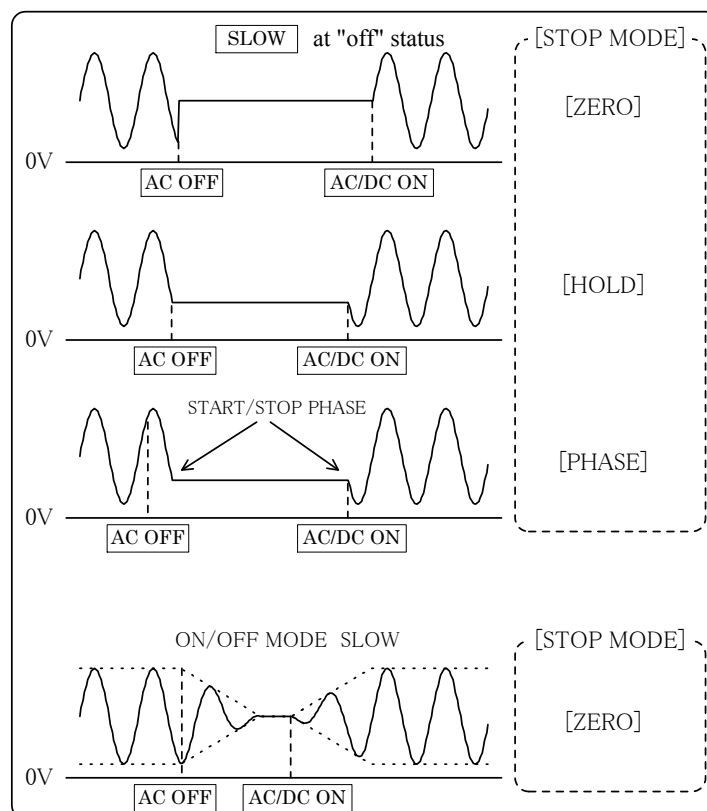

Fig. 4-7 Oscillator stop mode

The oscillator output is the same for [HOLD] and [PHASE] regardless of the setting for [ON/OFF MODE SLOW].

The starting phase at the time of pressing the AC OFF key in the [HOLD] mode and also the starting phase at the time of pressing the AC/DC ON key in the [PHASE] mode, individually, are the phase right before the key actions, but not the phase that has been set by the [START/STOP PHASE] setting.

[START/STOP PHASE]

This is used to set the phase of the oscillator output with which the oscillator start to produce, or stop producing, the output waveform. This setting is valid when the [STOP MODE] is set at [PHASE]. Note, however, that the phase of the output waveform at the start or stop of frequency sweep is nothing to do with this setting. The phase setting by [START/STOP PHASE] is valid or effective only when both the AC and DC are off.

The phase is defined assuming that the oscillator output waveform is sinusoidal. Therefore, the setting of 90 deg. in phase means the maximum amplitude in the positive phase region, for example.

[WAVE FORM]

This is used to set the output waveform. Select one from among [SINE](sinusoidal waveform), [SQUARE](square waveform) and [TRIANGLE](triangular waveform).

[ON/OFF MODE]

Set the oscillator output ON/OFF mode.

[QUICK] : The oscillator output is immediately set as soon as an ON/OFF key is pressed.

[SLOW] : The oscillator output gradually changes, taking approximately 10 seconds.

If you switch the oscillator output voltage on or off while [SLOW] is set, the oscillator output voltage changes slowly, but not quickly or instantly. This function of the FRA5097 is especially effective, for example, not to cause shocks to a vibrator when the FRA5097 output is fed to the vibrator via a power amplifier.

The rate of change in the output level is as shown in the figure below.

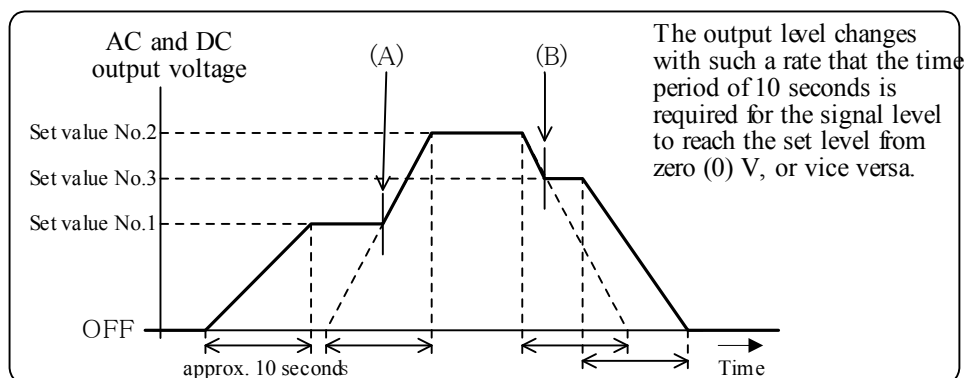

Fig. 4-8 Oscillator output voltage variation in the SLOW status

The oscillator output voltage level changes continuously when the oscillator status is “off” either at the start or the end of the SLOW operation; i.e., changing the output from off to on or from on to off. Note, however, that, when no “off” status is involved at the start nor the end of oscillator output voltage level change (e.g., from the set value No.1 to No.2, from the set value No.2 to No.3, etc.), a spike-like discontinuity for the duration of about 10 ms appears at the oscillator output voltage at the timing of (A) or (B) in the figure above (Fig.4-8).

Setting [SLOW] is valid only when the oscillator stop mode [STOP MODE] is at [ZERO] (See “Fig. 4-7 Oscillator stop mode”). However, if you change the [STOP MODE] into [HOLD] or [PHASE] during the SLOW OFF operation (i.e., while the amplitude is changing slowly), the oscillator output stops at the time point of [STOP MODE] change with the amplitude at the same time point. The following figure (Fig.4-9) shows, as an example, the waveform variation of the oscillator output when the stop mode [STOP MODE] is changed from [ZERO] to [HOLD] during the SLOW OFF operation.

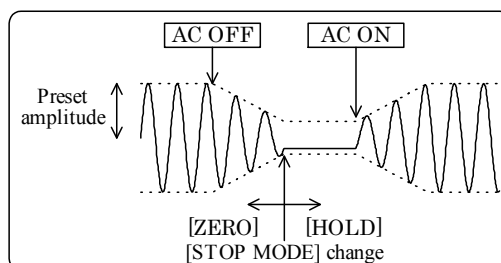

Fig. 4-9 Change of Stop mode during SLOW OFF

4.6 Display setting

Use the menu [Graph] to set parameters, states, etc. pertaining to the graph display. Since the measurement data are stored in the internal buffer, you need not repeat the previous measurement when changing the display format.



4.6.1 Setting display format

The FRA5097 offers two (2) display modes available to display measurement data on the screen; one is the [SINGLE] mode where only a single graph is displayed on the screen and the other is the [SPLIT] mode where two graphs are displayed with one in the upper part and the other in the lower part of the screen by splitting it into two by the horizontal line in the middle of the screen.

Use the menu [Graph][WINDOW STYLE] and select either [SINGLE] or [SPLIT].

In the [SPLIT] mode, the graph surrounded by blue rim is active (rewriting is possible and the cursor function is effective). Settings are possible for individual graphs separately for [GRID], [DISPLAY MODE], [ANALYSIS MODE] and [PHASE RANGE].

CAUTION

In the following type operations, when the Screen  and  keys are pressed, the graph disappears.

- The displayed data have been deleted.
The displayed data have been deleted by [MEMORY][DELETE MASS DATA] or [MEMORY][DELETE PERMANENT DATA].
The graph remains unchanged immediately after deletion.

If you press one of the SCREEN   keys after one of the following actions has been taken, the other displayed graph will disappear.

- After the measurement in the [SINGLE] mode has been done, another set of measurement was made by changing the mode into [SPLIT] for the first time. In this case, the other graph is still displayed showing the previously measured data.
- After data have been loaded from a disk in the [SINGLE] mode, another set of measurement was made by changing the mode into [SPLIT] for the first time. In this case, the other graph is still displayed showing the data that have been loaded from the disk.

4.6.2 Setting display scale

There are two (2) alternatives available in the display scale setting: the auto scale and the manual scale.

a) Auto scale

Use the menu [Graph][AUTO SCALE] and set it [ON]. The scales of x axis and y axis will automatically be adjusted at optimum according to analyzed data. Set the initial display range at measurement through using the menu [Graph][SCALE].

b) Manual scale

Use the menu [Graph][AUTO SCALE] and set it [OFF]. Then, the auto scale function becomes invalid and the display range will be fixed at the state that has been set through [SCALE].

When the x axis is assigned for frequency in the graph, the displayed range in the x axis will always be the sweep frequency range specified by [MIN FREQUENCY] and [MAX FREQUENCY] in the menu [Measure][SWEEP FUNCTION], irrespective of the ON/OFF status of the auto scale [AUTO SCALE].

4.6.3 Setting grids

Use the following menus which are located in the level just below the menu [Graph] to set the grid display:

- [GRID] : When this is [ON], grids are displayed.
- [GRID TYPE] : Solid lines are displayed at the setting of [SOLID LINE] and broken line are displayed at the setting of [BROKEN LINE].
- [GRID STYLE] : This enables to select appropriate styles of grids to be displayed.
 - [X] : Grids are displayed only for the X-axis.
 - [X-Y1] : Grids are displayed both for the X and Y1 axes.
 - [X-Y2] : Grids are displayed both for the X and Y2 axes.
 - [X-Y1-Y2] : Grids are displayed for all of the X, Y1 and Y2 axes.

Note that the [X-Y1-Y2] selection is valid only during the display mode ([Graph][DISPLAY MODE]) of the graph, which is set so that two traces are displayed as shown in the following table .

Table 4-5 Display mode that allows [X-Y1-Y2] grid display

X axis	Y1 axis	Y2 axis
logF F	dBR logR R	θ
logF F	logA log(-A)	logB log(-B)
logF F	A	B

⚠ CAUTION

When grid style is selected for X-Y1-Y2, two types of grid are displayed on the Y axis. If preferred for clarity, the grids can be overlapped as described below.

- 1) Set the [AUTO SCALING] in the Graph at "OFF".
- 2) Calculate the difference between the upper and lower limits of the phase scale that you want to display and divide the difference by six (6). Express the divided value as $\Delta\theta$. The phase grid interval is obtained according to the following:

	Phase grid interval
For $15.0 \leq \Delta\theta < 22.5$:	15.0
For $22.5 \leq \Delta\theta < 37.5$:	30.0
For $37.5 \leq \Delta\theta < 67.5$:	45.0
For $67.5 \leq \Delta\theta < 135.0$:	90.0

- 3) Multiply by arbitrary integers the phase grid interval that has been obtained above. Find two values from among the phase grid interval multiplied by integers so that the two values individually are the closest to the upper and lower limits of the phase grid interval which you want to display. Set these two values individually for the [θ MAX] and [θ MIN] in the [SCALE]. Then, phase grids will be drawn and displayed so that the number of the phase grids is the quotient of the difference between the values set for [θ MAX] and [θ MIN] divided by the phase grid interval. The afore-mentioned quotient is called the "phase grid division number" hereunder.
- 4) Next, calculate the difference between the upper and lower limits of the gain scale that you want to display, and then divide the difference by the phase grid division number. Express the divided value as ΔR . The gain grid interval is obtained according to the following:

	Gain grid interval
For $0.75E \pm n \leq \Delta R < 1.5E \pm n$:	$1.0E \pm n$
For $1.5E \pm n \leq \Delta R < 3.5E \pm n$:	$2.0E \pm n$
For $3.5E \pm n \leq \Delta R < 7.5E \pm n$:	$5.0E \pm n$
For $7.5E \pm n \leq \Delta R < 15.0E \pm n$:	$10.0E \pm n$

- 5) Multiply by arbitrary integers the gain grid interval that has been obtained above. Find two values from among the gain grid interval multiplied by integers so that the two values individually are the closest to the upper and lower limits of the gain grid interval which you want to display. The difference between these two values must be equal to the "phase grid division number". Set these two values individually for the [dBR MAX] and [dBR MIN] in the [SCALE].
- 6) Lastly, set [X-Y1] or [F-Y2] for the [GRID STYLE].

(EXAMPLE:) The following describes an example of the procedure of finding setting values for the display scale according to the above-mentioned principle, assuming the maximum gain of 110 dB, the minimum gain of -10 dB, the maximum phase of 170 ° and the minimum phase of -170 ° :

- First, obtain the phase grid interval, and then, set the [θ MAX] and [θ MIN] in the [SCALE]:
 Since $\{170 - (-170)\} \div 6 = 56.7$, the phase grid interval is determined to be 45.
 The two values closest to 170 and -170, individually, which are selected from among {45 multiplied by integers}, are found to be 180 and -180. Set 180 and -180 for [θ MAX] and [θ MIN], respectively, in the [SCALE].
 The phase grid division number is calculated to be 8.
- Next, Calculate the gain grid interval, and set the [dBR MAX] and [dBR MIN] in the [SCALE]:
 From $\{110 - (-10)\} \div 8 (= \text{phase grid division number}) = 15$, the gain grid interval can be obtained as 20. Set either 120 and -40, or 140 and -20 for [dBR MAX] and [dBR MIN], respectively, in the [SCALE].

4.6.4 Setting markers

This instrument has a function of displaying markers in the graph, so that you can accurately read measurement data and calculated data in the graph. The figures that have been read by markers are displayed in the data display portion located in the top (upper) part of the graph on the screen. The marker setting is done at the following sub-menus in the level lower from the menu [Graph][FORMAT]:

- [MARKER] : Markers are displayed on the screen at the [ON] setting.
- [MARKER TYPE] : This is used to select marker types from the following.
 - [DATA] : Data marker. The marker moves along the data in the graph.
 - [LINE] : Line marker. Straight lines parallel to the x- or y-axis move in the graph.

The following descriptions apply to the status where the [MARKER] is set at [ON] and markers are displayed on the screen.

a) How to use data markers

There are two types of data markers: normal markers and delta markers. You can read the gain difference or the phase difference between those at two different measurement frequencies by using these markers.

The normal marker is displayed in “*”, and the delta marker is displayed in “Δ”. The mark of “↕” is displayed together with the marker to indicate that the marker is active, which means that the marker can be moved by knob actions (See “**Fig. 4-10 Data marker display**”). When the ΔSET lamp is lit off, the normal marker is active; and when the ΔSET lamp is lit on, the delta marker is active. Every time when you press the ΔSET key, the ΔSET lamp is lit on and off alternatively.

The data marker operation depends upon the status of which marker, normal or delta marker, is active.

- The normal marker is active (i.e., ΔSET lamp is off):
 - Turn the knob and the normal marker moves along the data in accordance with the knob action.
 - The data display portion of the screen displays the read out data that have been read by the normal marker.
- The delta marker is active (i.e., ΔSET lamp is on.):
 - Turn the knob and only the delta marker moves.
 - The data display portion of the screen displays the difference from normal marker data.

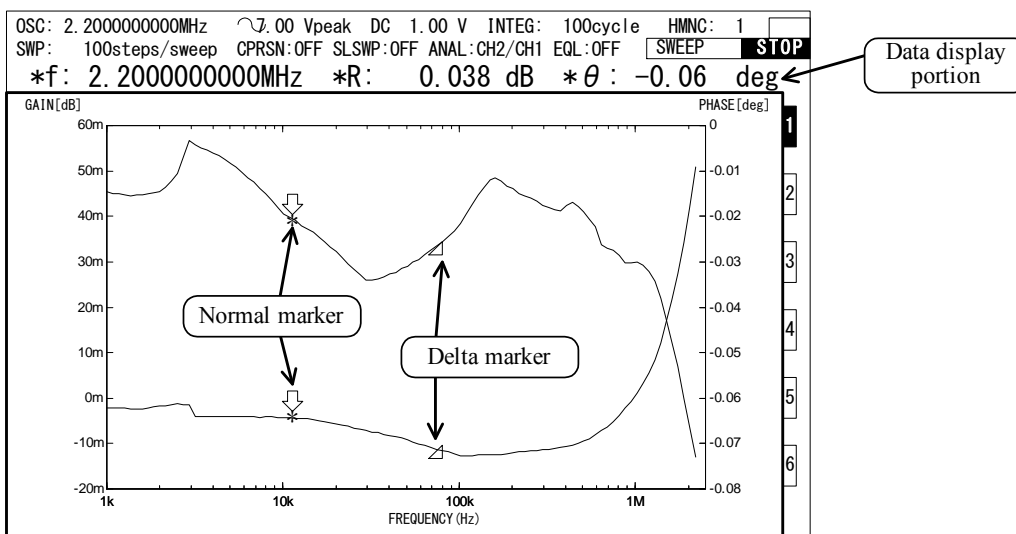
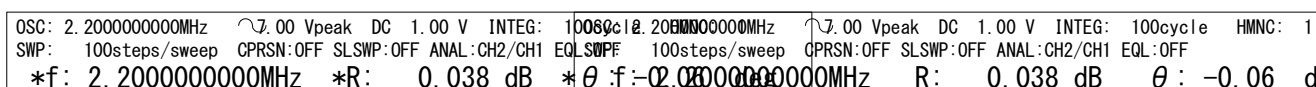

Fig. 4-10 Data marker display

When markers are displayed in the screen, a mark of “*” is attached just before the displayed item (e.g., f, R, θ , etc.), which is to indicate the value is the one read out by the marker. The mark “*” is not displayed when frequency sweep measurements are being done (See Fig. 4-11 data display examples).



During marker being displayed

During frequency sweep measurement

Fig. 4-11 Examples of data display

b) **How to use line markers**

Line markers are displayed in two forms; one is a straight line parallel to the x axis (i.e., y axis marker) and the other is a straight line parallel to the y axis (i.e., x axis marker). There are, again, two types of markers for each form of markers: normal markers and delta markers. The normal marker is displayed in solid line and the delta marker is displayed in broken line. The table below shows which line markers are active under certain combination of lamp status (lamps referred here are those of \blacktriangleleft , \blacktriangledown and Δ SET.). Active markers are those which move by knob actions.

Table 4-6 Active line markers

Lamps lit on		Active line marker
Δ SET	\blacktriangledown \blacktriangleleft	
off	\blacktriangleleft	x axis normal marker
off	\blacktriangledown	y axis normal marker
on	\blacktriangleleft	x axis delta marker
on	\blacktriangledown	y axis delta marker

Active line markers accompany a mark “↕” (x axis marker) or “↔” (y axis marker) at intersections of x axis or y axis, respectively, in the display. (See the figure below.)

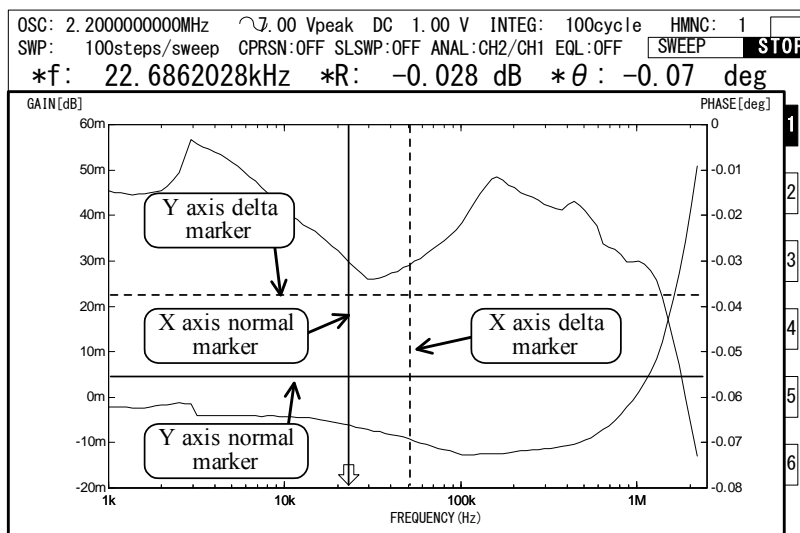

Fig. 4-12 Line marker display

The line marker operation depends upon the status of which marker is active.

- The x axis normal marker is active (i.e., ◀▶ and ΔSET lamps are off):
Turn the knob and the x axis delta marker also moves horizontally to right and left in accordance with the knob action.
The data display portion in the screen displays the read out data of the intersection of the x axis normal marker with the measurement data curve.
- The y axis normal marker is active (i.e., ◆ and ΔSET lamps are off):
Turn the knob and the y axis delta marker also moves vertically up and down in accordance with the knob action.
The data display portion of the screen displays the read out data of the intersection of the y axis normal marker with the measurement data curve. The frequency is not displayed.
- The x axis delta marker is active (i.e., ◀▶ and ΔSET lamps are on.):
Turn the knob and only the x axis delta marker moves horizontally to right and left.
The data display portion of the screen displays the difference between “the intersection of x axis delta marker with the data curve” and “the intersection of x axis normal marker with the data curve”.
- The y axis delta marker is active (i.e., ◆ and ΔSET lamps are on.):
Turn the knob and only the y axis delta marker moves vertically up and down.
The data display portion of the screen displays the difference between “the intersection of y axis delta marker with the y axis” and “the intersection of y axis normal marker with the y axis”.

4.6.5 Setting phase display range

Use the menu [Graph][FORMAT][PHASE RANGE] to select one of the three phase display ranges in the following:

- [± 180deg]
- [0 - 360deg]
- [-360 - 0deg]

4.6.6 Selecting display data

You can display the data which have been read out from the data memory or the USB flash drive. The data are displayed with the optimum display range for the read out data when the [AUTO SCALE] is set at ON, and with the display range as specified in the [SCALE] when the [AUTO SCALE] is set at OFF.

Use the menu [Graph][DATA SELECT] to select the data storage to be read out from among [MASS DATA], [PERMANENT DATA] and [DISK DATA].

[MASS DATA]

The data recorded in the mass data memory are selected and displayed.

The functions of function keys are the following:

- [PREV] : To return to the previous page.
- [NEXT] : To go to the next page.
- [↑] : To move the cursor up by one line.
- [↓] : To move the cursor down by one line.
- [ASSIGN] : To display in the graph the data currently pointed by the cursor.

[PERMANENT DATA]

The graph recorded in the permanent data memory is selected and displayed. The functions of function keys are the same as for the [MASS DATA].

[DISK DATA]

The data are read out from the USB flash drive and displayed. File names are displayed in the list representation. Enter the desired data file name up to .DAT in full and press the [YES] key. The data read out from the USB flash drive will be deleted from the data memory when another set of data is further read out from the USB flash drive. If you want to maintain the data, store them in the master data memory or in the permanent data memory.

 **CAUTION**

It can happen that the data read out from USB flash drive cannot be loaded into the memory due to insufficient capacity of the memory, when the data volume of the file to be read out from the USB flash drive is too large. Take the following measures when the memory capacity is insufficient for loading the data:

- 1) Delete unnecessary data in the mass memory.
- 2) If you have any data that have not yet been stored in the USB flash drive since the data have just been taken, and if those data are unnecessary for you, press the function key [DELETE CUR.TAG] in the menu [Memory] to delete the data.

If you find you cannot yet load the data from the floppy disk even after you have taken the measures above, record and store into the permanent memory all those data that are in the mass memory and also those data that have not yet been stored in either the mass memory or the permanent memory, which have been left as measured. Then, switch off the power supply of the FRA5097 and switch it on again to load the data from the USB flash drive.

4.7 Equalization

The error compensation capabilities of the FRA5097 involve not only the calibration function for self error compensation but also the equalization function that cancels measurement error components arising from sensors, cables, etc.

4.7.1 Operation of equalization

Equalization is done through the two following steps: **a)** measurement of error components in the measurement system, and **b)** compensation for errors to correct data involving the DUT (device under test)(i.e., equalization). Fig. 4-13 indicates an example of equalizing.

This example assumes that you want to have the correct characteristics of Fdut through canceling errors caused/brought by “Amp”, “Probe1” and “Probe2”.

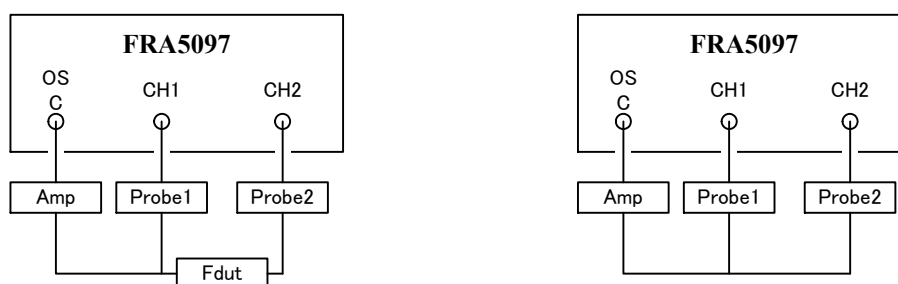

a) Measurement connection involving DUT

b) Connection for measuring measurement system errors

Fig. 4-13 Measurement/DUT system

a) Measurement and storage/recording of measurement system errors

- 1) Connect as shown in Fig. 4-13b to cancel only the desired measurement system.
- 2) Set the menu [Measure] [BASIC FUNCTION] [EQUALIZING] at [OFF].
- 3) Set all items and parameters in identical settings to those at the time of measurement of Fdut.
- 4) Store/record the measured frequency characteristics (i.e., measurement system errors) to the EQL memory. Press the function key [EQL STORAGE] in the menu [Memory][STORAGE] to do this.

b) Equalization

After measuring and recording the error component, connect the equipment, including the device under test (dut) as indicated in Fig. 4-13a.

- 1) Set the menu [Measure][BASIC FUNCTION][EQUALIZING] at [ON] to enable the equalization function.
- 2) Perform measurement by the measurement system involving the Fdut. The measurement outcome is the characteristics of Fdut only, with the measurement system errors canceled.
- 3) Set the [EQUALIZING] at [OFF] to terminate equalizing operation, in the same menu as described in 1) above.

4.7.2 Principle of equalization

The equalization principle is described below with respect to Fig. 4-14.

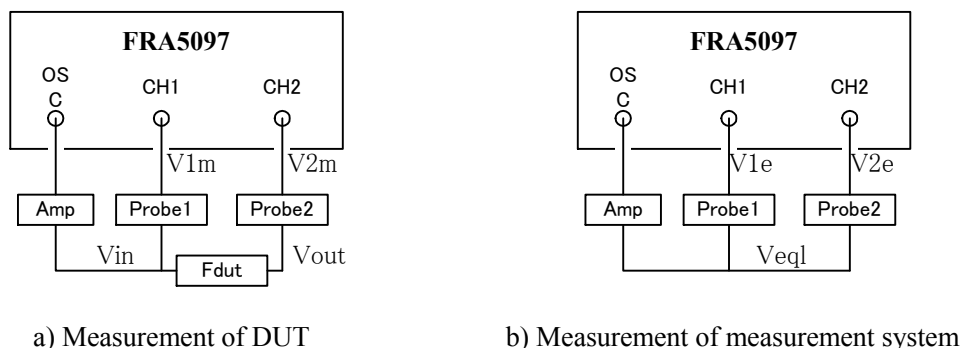

Fig. 4-14 Principle of equalization

- 1) Measure by using the connection shown in Fig. 4-14b. Set the Amp output voltage level at V_{eql} to have CH1 and CH2 input voltage levels, V_{1e} and V_{2e} , respectively, to be the following:

$$V_{1e} = V_{eql} \times \text{Probe1}$$

$$V_{2e} = V_{eql} \times \text{Probe2}$$

- 2) Record/store the measured data above in the EQL memory as the equalization data. The data for CH2/CH1 are recorded/stored in the EQL memory. Therefore, the content of the EQL memory will be as follows:

$$\text{EQL} = \frac{V_{2e}}{V_{1e}} = \frac{\text{Probe2}}{\text{Probe1}}$$

- 3) Connect as shown in Fig. 4-14a and measure the overall dut system. Putting the Amp output voltage to be V_{in} and the F_{dut} output voltage to be V_{out} , you can obtain input voltages of CH1 and CH2, V_{1m} and V_{2m} , respectively, as follows:

$$V_{1m} = V_{in} \times \text{Probe1}$$

$$V_{2m} = V_{out} \times \text{Probe2} = V_{in} \times F_{dut} \times \text{Probe2}$$

- 4) Equalize these data by using the data stored in the EQL memory. Since the actual processing of equalization comprises division operations, i.e., the CH2 measurement value divided by the value stored in the EQL memory, CH1 and CH2 voltage levels after equalization, V_1 and V_2 , respectively, will be as follows:

$$V_1 = V_{1m} = V_{in} \times \text{Probe1}$$

$$V_2 = \frac{V_{2m}}{\text{EQL}} = \frac{V_{in} \times F_{dut} \times \text{Probe2}}{\text{Probe2} / \text{Probe1}} = V_{in} \times F_{dut} \times \text{Probe1}$$

- 5) Display the ratio of CH1 to CH2 (i.e., ratio of V_1 to V_2) to cancel the effects of V_{in} and Probe1 . The displayed data show F_{dut} , the characteristics of the DUT (device under test). Note, however, that the effect of Probe1 will be left unremoved, if the absolute value of CH1 or CH2 is displayed.

4.8 Harmonics analysis

The FRA5097 analyzes measured data by the use of DFT (discrete Fourier transform) to provide measurement/analysis results. Normally, measurement/analysis is made for the oscillator output frequency components. However, the FRA5097 can also measure and analyze those frequency components that are integer-multiplication of the oscillator output frequency (i.e., frequency harmonics components), if you set the order of frequency harmonics. You can measure and evaluate DUT's non-linear characteristics by using the harmonics analysis operation.

Use the menu [Measure][BASIC FUNCTION][HARMONICS ANALYSIS] to set the order of harmonics. Select the order from the range of 1 to 10, which enables you to analyze up to tenth order harmonics. If you set the order to be 1, the fundamental frequency analysis will be made (for the oscillator output frequency). Setting the harmonics order to be between 2 and 10 will enable harmonics analysis.

The oscillator output frequency is displayed in the frequency axis of the graph on the LCD screen. Therefore, the graph display and the maximum measurable frequencies are limited to 15MHz/n, when you set the order of harmonics to be n.

CAUTION

It is possible to set the frequency sweep range beyond 15 MHz/n even if you have set the order of harmonics at n (>1). If you start frequency sweep measurement with the setting of the order of harmonics of n (>1), the range of the graph will be displayed according to your setting and also an information message will be displayed stating that the actual plotting of data in the graph will be limited up to 15 MHz/n.

If you try to perform a SINGLE measurement at a frequency beyond 15 MHz/n, the measurement will not be made and the error message will be displayed.

When the order of harmonics is set at n (>1), the measurement processing will involve n-times of integration period for removing the fundamental frequency component. As a consequence, the time period required for measurement and sweep will be increased to approximately n-times compared with otherwise. The graph frequency axis scale is in relation to the fundamental frequency.

4.9 Amplitude compression

The oscillator output amplitude level is so controlled that the amplitude level of the DUT (device under test) is kept at a certain level. This is to prevent saturation of, or damages to, the DUT, when the DUT amplitude response has a high peak level.

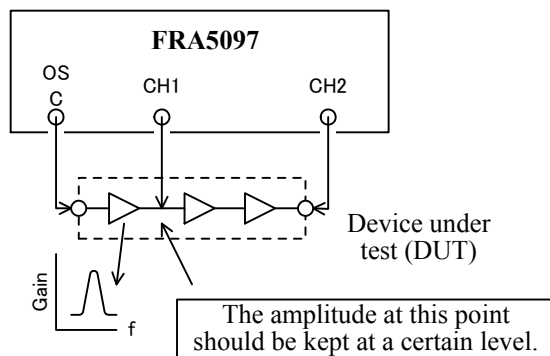

Fig. 4-15 Amplitude compression

The amplitude control is done in the following way:

- 1) Measurement is done once, with the current setting value of the oscillator output voltage.
- 2) Comparison is made between the measurement data and the compression level setting. If the comparison result (i.e., difference) is within the permissible range, the measurement at the frequency is completed.
- 3) If the difference is beyond the permissible range, the oscillator output voltage is controlled according to the DUT gain, which is obtained from the measurement data.
- 4) Measurement is made again and the measurement data is again compared with the compression level setting to find the difference. If the difference is still beyond the permissible range, repeat the measurement and comparison. If the measurement and comparison are repeated for the preset number of times and still the difference is beyond the permissible range, the measurement at this frequency terminates with an error message.
- 5) The measurement data will be output.

The FRA5097 has a provision that the maximum oscillator output level can be set so that it will not exceed the maximum permissible DUT input level, when the oscillator output voltage is controlled according to the step 3) above. The FRA5097 also has a provision that the correction voltage factor (correction voltage = the difference between the current output voltage and the next output voltage) can be changed so that the measurement system can be applied to such DUTs that do not like steep input voltage change or such DUTs whose amplification gain varies according to the operating level.

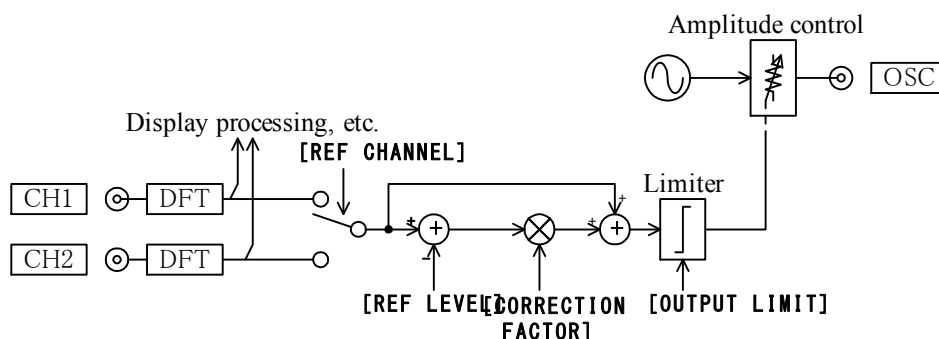

Fig. 4-16 Principle of amplitude compression

Use the menu [Measure][AMPLITUDE COMPRESSION] to set the amplitude compression. The menu compression setting items are indicated in Table 4-7.

Table 4-7 Amplitude compression setting items

Items	Descriptions
[FUNCTION]	To be set at "ON" when you want amplitude compression.
[REF CHANNEL]	To be used to set the channel (CH1 or CH2) for level monitoring.
[REF LEVEL]	To be used set the reference level to be measured in the [REF CHANNEL].
[OUTPUT LIMIT]	To be used to set the oscillator maximum output voltage.
[ERROR]	To be used to set the permissible difference between the [REF LEVEL] set value and the measured data.
[RETRY TIMES]	To be used to set the maximum repeatable number of measurement.
[CORRECTION FACTOR]	To be used set the voltage correction factor.

An example of amplitude compression is shown below where the voltage correction factor [CORRECTION FACTOR] has been set at 70%. It is also assumed that the current oscillator setting voltage is 1 V and the reference level [REF LEVEL] of the oscillator is 2 V.

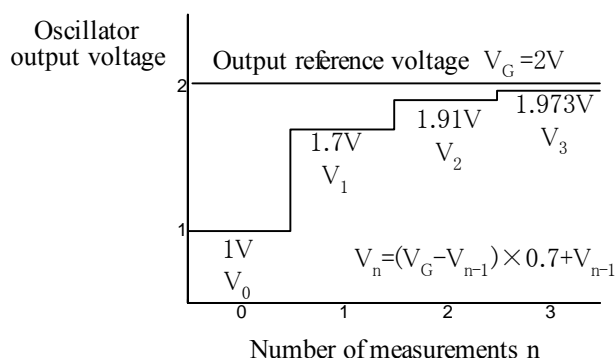

Fig. 4-17 Example of output correction (70%)

Note that the oscillator output voltage is different from the amplitude set in the menu [OSC][AMPLITUDE], even if you have disabled the amplitude compression function by setting the [FUNCTION] at "off".

⚠ CAUTION

Error message 15 may appear during amplitude compression. This is not a malfunction.

See 7.1 error message.

Review [ERROR], [RETRY TIMES] and [CORRECTION FACTOR] settings. Again conduct measurement.

4.10 Frequency axis high density slow sweep

When measurement data variation is very sharp, you would want to have more correct data in a short period of time. You can be satisfied by measuring in detail the sharp data portion including their immediate front and aft portions (high density slow sweep measurement, SLOW SWEEP).

There are two (2) modes in the SLOW SWEEP measurement mode as follows:

- Auto mode : Sweep density is automatically increased only for the frequency portion with sharp data variation during sweep measurements.
- Manual mode : The high density low sweep mode is set “on” or “off” manually during sweep measurements.

Use the menu [Measure][SLOW SWEEP] window to set the high density slow speed mode.

- [FUNCTION] : This is set “ON” when the high density slow sweep mode is used.
- [SLOW SPEED MODE] : This is used to select MANUAL/AUTO.
- [CHANNEL] : This is used to select the channel in which to monitor if there is any sharp data variation in the measurement.
- [VARIATION] : If measured data are found to vary by more than the amount specified in [VARIATION], the measurement is done in the high density slow sweep mode.

The sweep frequency density depends on the following elements: the measured data status of whether or not there is a sharp data variation, the mode setting status of MANUAL/AUTO and the function key setting status of [MANUAL ON] or [MANUAL OFF]. See Table 4-8 High density slow sweep.

Table 4-8 High density slow sweep

Mode	Frequency range without sharp data variation		Frequency range with sharp frequency variation	
	[MANUAL ON]	[MANUAL OFF]	[MANUAL ON]	[MANUAL OFF]
MANUAL	Quadruple density	Normal density	High density slow sweep	Normal density
AUTO	Normal density		High density slow sweep	

Normal density : The density that has been set through [Measure][SWEEP FUNCTION] [SWEEP RESOLUTION].

Quadruple density: Frequency sweep whose frequency density is quadruple of the normal density.

In the high density slow sweep mode of operation, which occurs when a sharp data variation is detected, the frequency sweep density is automatically increased in the frequency sweep measurement until the value set in the [VARIATION] is reached. In the manual mode, the sweep density returns to normal density, either when the function key [MANUAL OFF] is pressed, or when the sweep measurement is completed.

CAUTION

If the value set in [VARIATION] is too low, the sweep density becomes extremely high and the sweep operation could stop on the way due to the memory capacity being full. Note that the FRA5097 has the maximum number of frequency point measurement capacity of 20,000 due to the memory capacity available.

4.11 Calculation functions

The FRA5097 has the following capabilities: to apply various calculation operations to the frequency characteristics measured by the FRA5097, to display the calculation results on the LCD screen and to save/store the calculation results in floppy disks.

There are three (3) types of calculation operations available for the FRA5097, which are as follows:

- [+ - × ÷] : Four rules of arithmetic
- [d/dt : ∫ dt] : Differentiation and integration
- [OPEN/CLOSE] : Open-loop and closed-loop conversion

Use the menu [Calc] to set calculation operations.

Another calculation operation can be applied to a result obtained through a calculation operation.

4.11.1 Operation of four rules of arithmetic

There are three types of operations of four rules of arithmetic as follows: calculation between data values, calculation between a data value and a numerical value, and calculation between numerical values.

Use the menu window [Calc] [+ - × ÷] to set the operation of the four rules of arithmetic.

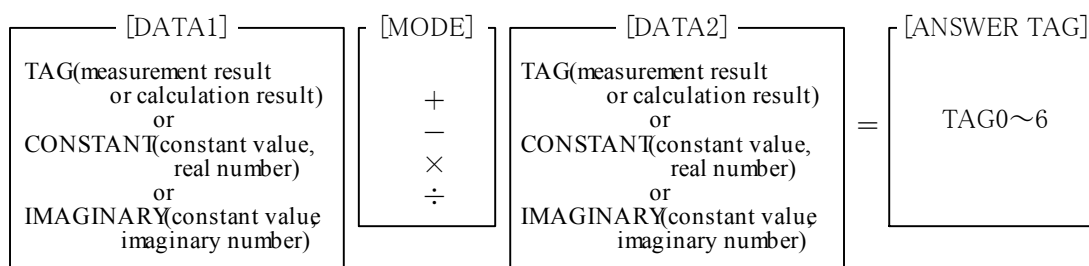

Fig. 4-18 Functions/operations of four rules of arithmetic

Select one from among 0 to 6 to set the TAG number for [DATA1] or [DATA2]. The number 0 indicates the currently displayed TAG number. The measurement results are always contained in Tag 1.

Press the function key [START] to start calculation and to display the calculation result in the ANSWER TAG.

Complex numbers can be produced by adding constant values of real and imaginary numbers. If you need imaginary or complex numbers to use them in calculation operations of differentiation, integration or open- and closed-loop conversion, produce them by using calculation operations of four rules of arithmetic.

4.11.2 Differentiation and integration

Operations of differentiation, second order differentiation, integration and double integration in the time domain of measurement data are available.

You can use these operations to convert the velocity data into the acceleration or position data.

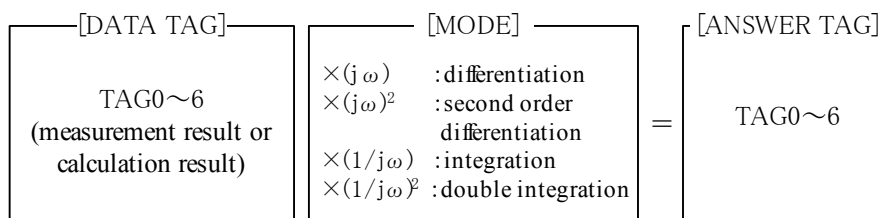

Fig. 4-19 Differentiation and integration functions

Differentiation and integration operations can be applied only to TAG data. The frequency of the measurement data is applied to the calculation result.

Differentiation of the measurement data in the time domain corresponds to multiplication of $j\omega$ ($=j2\pi f$) by the measurement data in the frequency domain. In the same theory, the second order differentiation in the time domain corresponds to multiplication of $(j\omega)^2$ by the data. In the similar manner, integration and double integration (double integrals) of measurement data in the time domain corresponds to division of the measurement data by $j\omega$ and $(j\omega)^2$, respectively. You can calculate higher order differentiation (higher order derivatives) and multiples of integration (multiple integrals) by repeating operations of differentiation and integration, respectively. Differentiation leads the phase by 90 degrees and integration lags the phase by 90 degrees. The measurement results are always contained in Tag 1.

When you want to differentiate or integrate numerical values, apply operations of differentiation and integration after producing the required DATA TAG (complex numbers can also be used) through the use of the four rules of arithmetic functions.

Press the function key [START] to start calculation operations and to display the calculation result in the "ANSWER TAG".

4.11.3 Conversion between open and closed loops

In open to closed loop conversion, when negative feedback T_m is applied to open loop characteristics T_o , the closed loop characteristics T_c are derived. Conversely, when converting from closed to open loop, the open loop characteristics are derived from the closed loop T_c and negative feedback T_m .

Use the menu window [Calc][OPEN/CLOSE] to set the open- and closed-loop conversion.

- [DATA TAG] : To be used to set the TAG number of 0 - 6 (measurement and computation results) for the original data for calculation.
- [Tm] : To be used to set either the TAG number of 0 - 6 (measurement and computation results) for the frequency characteristics data of the negative feedback circuit or the constant value (real number).
- [MODE] : To be used to set either the open-loop to closed-loop conversion “ $T_o/(1+T_o \times T_m)$ ” or the closed-loop to open-loop conversion “ $T_c/(1-T_c \times T_m)$ ”.
- [ANSWER TAG] : To be used to set the data TAG number of 0 - 6 for storing the calculation result.

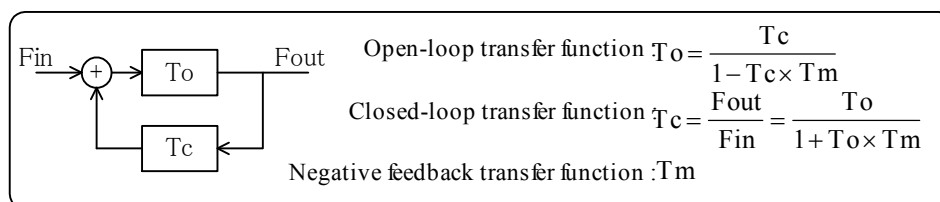

Fig. 4-20 Open-loop and close-loop transfer functions

The meaning of [DATA TAG] and [ANSWER TAG] depends on the status of [MODE] as follows:

[MODE]	[DATA TAG]	[ANSWER TAG]	Notes
$T_o/(1+T_o \times T_m)$	T_o	T_c	Open-loop to closed-loop conversion
$T_c/(1-T_c \times T_m)$	T_c	T_o	Closed-loop to open-loop conversion

Press the function key [START] to start calculation operations and to display the calculation result in the “ANSWER TAG”. If you want to use for T_m the data composed of an imaginary number or a complex number, perform calculation operations after producing the required data TAG through the use of the four rules of arithmetic function.

In this application, the open loop transfer function T_o cannot be derived from a single loop transfer function ($T_o.T_m$).

⚠ CAUTION

- The FRA5097 has the maximum memory capacity of 20,000 points. Therefore, the calculation capabilities are limited to approximately 6,000 data points for operations of the four rules of arithmetic or of the open- and closed-loop conversion using measurement data only, and to approximately 10,000 data points for operations of differentiation or integration, of the four rules of arithmetic or of the open- and closed-loop conversion using constant numbers and measurement data.
 - Recording/storage of data into memory
The data resulting from calculations will be deleted upon activation of consecutive calculations. If you need or want to later use calculation result data, record or store them in the master data memory or the permanent data memory.
 - Types of data
There are two types of data that you deal with. They are raw measurement data (RAW) and data that have been operated/calculated (OPERATED). For RAW data, calculations are performed according to the menu setting [Graph][FORMAT][ANALYSIS MODE] (selection from [CH1/CH2], [CH2/CH1], [CH1] and [CH2]). Check the setting status before starting calculation operations by all means.
After completion of calculation operations, OPERATED data are produced. When OPERATED data are again used for further calculations, you do not need to set [ANALYSIS MODE].
 - Operation of the four rules of arithmetic between data
The frequency of [DATA1] will be used for calculations when calculation operation of the four rules of arithmetic is applied to data (i.e., data vs. data). When this frequency is higher than the maximum frequency of [DATA2], the amplitude and phase of the data at the maximum frequency are used as the data of [DATA2]. Similarly, when the frequency of [DATA1] is lower than the minimum frequency of [DATA2], the amplitude and phase at the minimum frequency is used as the data of [DATA2].
When calculations between data are used for open- and closed-loop conversions, the frequency of [DATA] is used. The calculation methodology will be the same when the frequency is higher than the maximum frequency of the data of [Tm] and when the frequency is lower than the minimum frequency of the data of [Tm].
 - Operation of the four rules of arithmetic between constants
In the four rules of arithmetic operations between constants (i.e., constant vs. constant), the calculation frequency used will be the same as the actual frequency of the measurement which has been done according to the menu [Measure][SWEEP FUNCTION]. (For calculation purposes, the setting of [SLOW SWEEP] is treated as “OFF”.)
In certain settings, the volume of data could become too large to be stored in the memory.
When you want to produce complex numbers by applying the four rules of arithmetic operations to constant values, you can save the memory capacity by setting equal values for [MAX FREQUENCY] and [MIN FREQUENCY] of [SWEEP FUNCTION].
 - Calculation precision
The precision of the calculation result is 5 digits. Note that calculation errors would be generated when the actual open-loop gain is more than 10,000 times of the closed-loop gain in the closed- to open-loop conversion calculation.
 - Key operations during calculation
No key entries are accepted during calculation operations. Note that it will take a considerable period of time to complete calculations involving a large number of frequency points. Note, also, that all key entries during calculations will be invalid.
-

4.12 Auto-sequence

The FRA5097 has a feature of storing a sequence of key operations and of later reading out the stored key operation sequence (Auto sequence). You can repeat typical types of measurements in an effective manner by storing a series of complicated key operations involving settings, measurements, calculations and disk operations.

4.12.1 Recording/storage of key sequence

Select [WRITE MODE] in the menu [AutoSeq][MODE]. Then, press the **AUTO SEQ** key to turn the REC lamp “on”, which indicates key entries being recorded/stored, so that storage/recording of all key operations starts from this time on.

Press keys in a usual sequence, which you want to store/record. The sequence of the key operations will be stored/recorded, and, at the same time, will be responded so that the instrument functions as usual.

Press the **AUTO SEQ** key again to complete the key sequence storage. The REC lamp will be turned off to indicate the key sequence storage/recording having completed. Key operations during the REC lamp in the “off” status will not be stored.

CAUTION

- The operation itself of the **AUTO SEQ** key action is not recorded/stored.
 - The maximum number of key actions to be stored is 128. In addition, only one (1) set of key sequence can be stored.
 - If the storage buffer memory becomes fully occupied midway during the storage operation of a key sequence, an error message (“Sequence buffer overflow”) is displayed and the storage operation terminates at that point. The key operation sequence up to the point of the error message display will have been stored.
 - When any access, control or inquiry is made from the GPIB (i.e., when the status turns to REMOTE) during storage/recording operation of a key sequence, the storage/recording operation terminates with an error message (“discontinue to record”) displayed. The key sequence up to this point is discarded.
-

4.12.2 Executing key sequence

Select [RUN MODE] in the menu [AutoSeq][MODE]. Then, press the **AUTO SEQ** key to start execution of recorded key sequence operations with the PLAY lamp turned on, which indicates that the recorded key sequence is being run. Press the **GPIB LOCAL** key to terminate the execution midway during running the key sequence operation.

During key sequence, the operation proceeds as follows.

- OSC (oscillator) ON/OFF (including SLOW ON/OFF)
- Frequency sweep measurement, SINGLE measurement
- Calibration
- USB flash drive access
- Hard-copying output
- Calculations

CAUTION

- If an error occurs midway during execution of the key sequence (amplitude compression error “15 Amplitude compression failure” excepted, however), the execution terminates at that point.
 - If an overload occurs midway during execution of the key sequence, the execution is terminated only when either one of [SWEEP STOP] or [OSCOFF] in the menu [Input][ACTION] is [ON].
 - If a key sequence involving a REPEAT measurement is executed, the REPEAT measurement is repeated permanently without going to the next execution. Therefore, do not record/store/execute any key sequence involving REPEAT measurement. Press the **GPIB LOCAL** key to terminate the REPEAT measurement in the key sequence.
 - When any access, control or inquiry is made from the GPIB (i.e., when the status turns to REMOTE) during execution of key sequence, the execution is terminated.
 - During execution of key sequence operations, all key entries are ignored except for the **GPIB LOCAL** key.
 - If the work area memory cannot be secured at the time of starting execution, the execution does not start with an error message (“Memory overflow”) displayed.
-

4.12.3 Deleting key sequence

Select [DELETE] in the menu [AutoSeq] and press the **OPEN** key, first. Then, press the function key [YES] to delete the stored/recorded key sequence.

4.12.4 Other remarks on auto-sequence

a) File operations during recording/storage of and execution of auto-sequence

The recorded/stored key sequence can be saved or loaded in the USB flash drive together with the measurement condition file.

- When the measurement condition file is saved midway during the recording/storage of key sequence, the previously recorded key sequence will be stored in the disk.
- When the measurement condition file is loaded midway during the recording/storage of key sequence, the key sequence will once be rewritten by the loaded content, but it will again be rewritten by the new key sequence by the completion of recording/storage.
- When the measurement condition file is saved midway during the execution of key sequence, the currently recorded key sequence will be saved in the disk.
- When the measurement condition is loaded midway during the execution of key sequence, the recorded key sequence will be rewritten by the loaded sequence content. However, the sequence currently being executed will be maintained with the content at the start of execution until the sequence execution is completed. When again a sequence is executed afterwards, the newly loaded sequence will be executed.

b) Auto-sequence mode change during recording/storage of and execution of auto-sequence









If the auto-sequence is deleted midway during recording/storage of sequence, the sequence content is deleted, but it will be rewritten by the new key sequence after the recording/storage operation is completed.

If the auto-sequence is deleted midway during execution of sequence, the recorded sequence content is deleted, but the sequence currently being executed will be maintained with the content at the start of execution until the sequence execution is completed. However, if you try to execute a sequence again after the sequence has been completed, no sequence will be executed unless a sequence is again recorded, since the recorded content has already been deleted.

c) Miscellaneous

- Recording/storage and execution of a sequence cannot be done from the GPIB.
 - The auto-sequence mode turns to be [NON-ACTIVE] through execution of initialization [INITIALIZE]; however, the content of recorded sequence is maintained.
-

CAUTION

When you record any of the ITEM keys     in the key sequence, it sometimes occurs that the desired item is not properly selected depending on the key display status or on the currently selected item. If this occurs, select the desired item by using the item keys ITEM    , after the desired item is moved to the top by the function key [CURSOR TO TOP].

4.13 Simplified load/save of setting conditions

You can easily load/save the FRA5097 setting conditions from/to the USB flash drive without entering a file name. Storing the frequently used conditions in the USB flash drive lets you easily read and use such conditions.

4.13.1 Simplified condition load

If a condition file having the name “CURRENT.CON” is present in the USB flash drive when you press the CONDITION  key, then an information message for confirming whether to continue the load appears. To execute loading, press [CONTINUE] in the function display section in lower part of the LCD. By doing so, the setting conditions in “CURRENT.CON” are loaded.

4.13.2 Simplified condition save

Press the CONDITION **[LOAD]** key, then the FRA5097 setting conditions at that time are saved in the USB flash drive under the file name "CURRENT.CON" .

If a "CURRENT.CON" file is already present in the USB flash drive, then an information message appears and asks to confirm whether to save. To save, press the function key **[CONTINUE]**.

For information messages, see "7.1.1 List of information messages "

 **CAUTION**

The file name of the file loaded/saved by the CONDITION **[LOAD]** or **[SAVE]** key is always fixed to "CURRENT.CON" . This means that this feature can handle only one set of setting conditions.

To handle more than one set of setting conditions, assign a different file name to each of the setting condition files, and specify the file name when loading/saving.

For details, see "4.17 File operation".

4.14 Output to printer

The LCD screen data can be sent to the printer.

4.14.1 Mounting printing paper

Follow the following procedure to mount printing paper, when you use the FRA5097 for the first time since purchasing the instrument or when you want to change printing paper.

a) Open the cover

Open the printer on the top of the FRA5097. Use a coin or similar tool to turn and release stoppers, then open the cover.

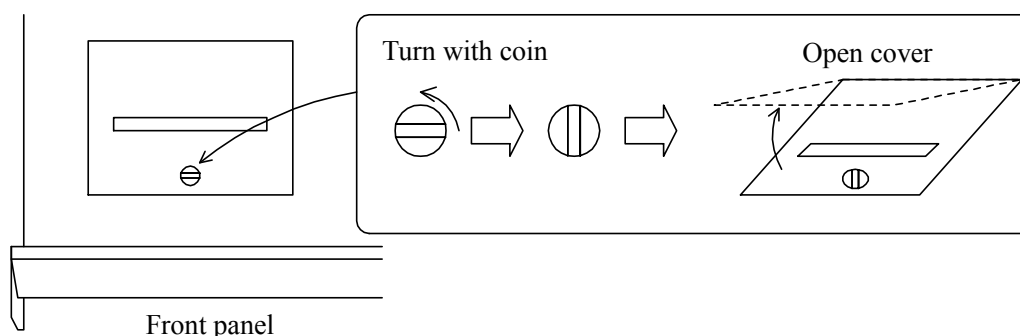

Fig. 4-21 Open the cover

b) Load printer paper

Load the paper as shown in Fig. 4-47. Pass the roller through the paper roll and set the roller with paper onto the holders. Insert fully to where the holder clicks into place and is supported by the holders.

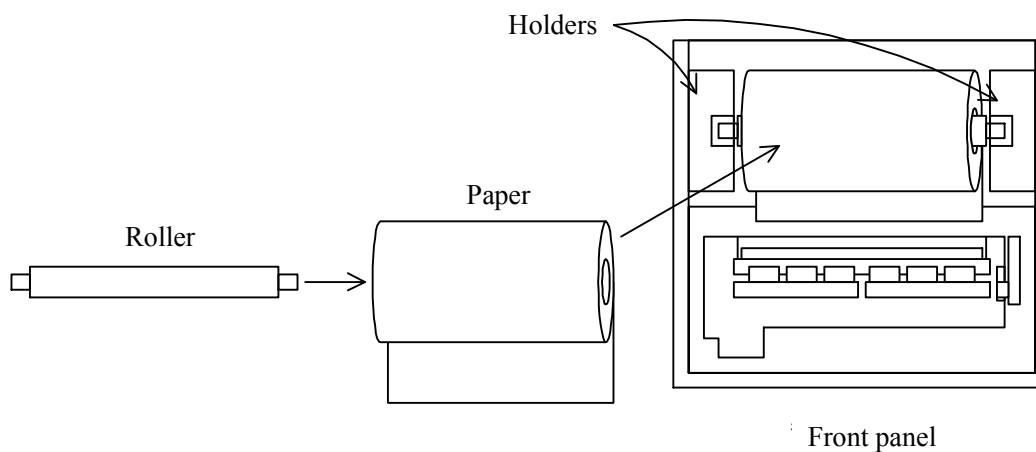
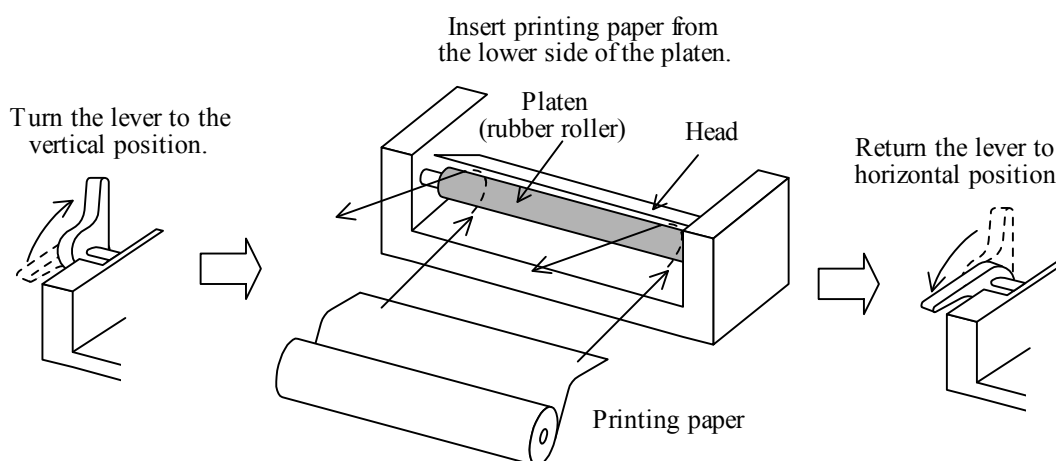

Fig. 4-22 Load printer paper

c) Loading printing paper

Load the printing paper in the printer (loading of printing paper) as described in this paragraph. Turn the lever at the right-hand side of the printer so that it is in vertical position, and insert printing paper from the lower side of the platen. In doing so, slightly move the paper to the right and to the left several times, so that the paper can be inserted under the platen smoothly. Fig. 4-23 shows the paper loading as viewed from the front panel. Hold the top edge of the printing paper that has come out from the head and pull the paper up further by approximately 5 cm. Pay attention in that the paper is placed perpendicular to the shaft and the head of the printer.

**Fig. 4-23 Loading printing paper**

Return the lever to the original horizontal position, after you have completed loading the printing paper. Printing can be made only when the lever has been restored to the perfectly horizontal position.

d) Restoring cover

Restore the printer cover to the original position, after inserting the top portion of the printing paper through the cover slit (i.e., wide rectangular hole through which printing paper comes out). Turn the stopper in the horizontal direction to press the lid into the cover to where a clicking sound indicates the lid is secure.

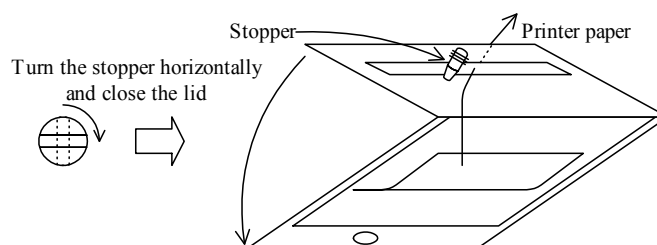
**Fig. 4-24 Cover attachment**

4.14.2 LCD screen hardcopy

To produce a hard copy, press **SCREEN COPY** **PRINTER**. The present LCD screen data will be printed out. When complete, grasp the end of the paper, position it toward the front panel and use the cover slit to cut the paper.

 **CAUTION**

- Be sure to use the designated printer paper (Seiko Instruments type TP-451C). Other types of paper can yield inferior print quality and possibly damage the printer.
 - If the paper is depleted, not properly set or the lever not correctly horizontal, the LCD shows Error 70: Printer didn't respond when **PRINTER** is pressed. In this case, check for paper supply and proper setting.
 - The printer is a thermal type and uses thermal paper. Since the print tends to fade over time, again copy the image onto regular paper when long term storage is intended.
Remove the printer paper before transporting the FRA5097. If left loaded, the paper can unravel and lead to possible damage during transport.
-

4.15 Output to USB flash drive

The LCD screen data can be saved to USB flash drive (Windows bitmap format). Use a USB flash drive (attached) and connect it to the USB port on the upper left of the pane.

When using USB flash drive, please note the following.

- Is directly inserted into the USB port (at upper left of the front panel) of the FRA5097, not via any USB-HUB or extension cable.
- Is not partitioned, but is constituted as one logical disk.

4.15.1 LCD screen hardcopy

Press **SCREEN COPY** **USB MEMORY** to produce a hard copy. The hard copy of the present LCD screen is stored as an image file.

The file, which is named FRA***.BMP, is stored in the root directory of the USB flash drive. *** can be set by [FILE NUMBER] in the range from 000 to 999. Each time the data is output to the USB flash drive, *** increments and returns to 0 when it reaches 1000.

File size is about 150 kB.

4.16 Calibration

In calibration operations, the frequency characteristics of amplitude and phase of the FRA5097 are automatically calibrated with reference to the internal oscillator. The calibration results are stored in the internal memory and will be used as calibration data for measurements.

Use the menu [Calib.], open the window [CALIBRATION] and press the function key [START] to start calibration operations. Calibration operations can be done only when the oscillator output is “off” for both AC/DC.

Press the **AC/DC OFF** key before starting calibration operations, to turn off the oscillator output.

When calibration operations start, the window “Calibration/Systemcheck” is displayed on the LCD screen.

<i>Calibration/Systemcheck</i> Calibrating . . 000000000***** <i>FRA5097 System program Version *.*</i> Copyright 1989..2006 NF Corporation
--

When all of “*” marks turn to “o” in the window “Calibration/Systemcheck”, calibration is completed and the measurement system is ready for use.

The measurement accuracy specifications for the FRA5097 are based on the status of immediately after calibration; therefore it is recommended that calibration operations are done immediately before conducting measurements.

4.17 File operation

The attached USB flash drive conforms to both USB 1.1 and 2.0 standards. Therefore, the measurement data saved by the FRA5097 can be read out and utilized by IBM PC/AT compatible machines.

Files are operated in the window menu [DISK] in the menu [Disk].

The following shows functions of the function keys that are displayed during file operations:





- [PREV] : To go back by one (1) page.
- [NEXT] : To go to the next page.
- [UPDATE] : To read in the file name again from the USB flash drive and to display it again. This function is used when the USB flash drive is changed midway in operations.

- a) DIR ... To display file name
- [ALL] : To display all files
 - [.DAT] : To display data files only
 - [.CON] : To display condition (measurement conditions) files only
 - [OTHERS] : To display only those files that have been prepared by other personal computers, but .DAT and .CON files excepted.

- b) SAVE ... To save measurement data and/or measurement conditions (storage)
- [DATA] : To save measurement data
 - [ALL] : To store all of the contents of the master data memory and the permanent memory as well as the displayed data into the USB flash drive. Three (3) digit serial numbers are automatically added after individual file names(5 characters, maximum). The order of storage is the following: 1st: display data, 2nd: mass data, 3rd: permanent data.
 - [DISPLAY TO DISK] : To store the displayed data in the USB flash drive
 - [MASS TO DISK] : To store one arbitrary set of data in the mass data memory into the USB flash drive
 - [PERMANENT TO DISK] : To store one arbitrary set of data in the permanent data memory into the USB flash drive
 - [CONDITION] : To save the setting condition



Select the menu and press the **OPEN** key to display the character string table (TABLE) in the screen. Pick up characters from this table (TABLE) and enter the file name (refer to "Character string entry" below). Press the function key [SAVE] after defining the file name by the **ENTER** key, to save the data and the conditions.

TABLE						
A	B	C	D	E	F	G
H	I	J	K	L	M	N
O	P	Q	R	S	T	U
V	W	X	Y	Z	.	0
1	2	3	4	5	6	7
8	9	!	#	\$	%	&
<	>	-	@	_	{	}

Character string entry : Select a character you want to enter by using the ITEM     key.

Press the MENU  key to display the selected character at the entry display portion at the bottom of the LCD screen and to shift the cursor to the right by one character at the entry display portion.

Repeat this operation when you want to enter more than one character.



Note that you can enter figures  -  from the ENTRY key also.



After entering a character string as you need, press the ENTRY  key to define the character string.

c) LOAD ... To load measurement data and setting conditions (to read in)

[DATA] : To load measurement data



[CONDITION] : To load setting conditions

Select the menu to display a list of files. Press the ITEM   key to select a file you want to read in. The selected file will be displayed in inverted characters. Press the function key [LOAD] to load the selected file.

If you want to specify the file name by yourself and load the file, press the  key in the state where a list of files is displayed. Pick up characters as you want from the TABLE (character string table) to enter the file name (See “Character string entry” above). Press the  key to define the file name. And then, press the function key [LOAD] to load (read in) the data and conditions.



A part of the measurement conditions is added to individual DATA files; it is required, however, that you load the CONDITION file also so that the FRA5097 is to be set at the same condition.

d) DELETE ... To delete the file



Press the ITEM   key to select a file you want to delete in the list of files displayed. Press the function key [DELETE] to delete the selected file.

e) RENAME ... To change the file name

• Entry of new file names

Select NEW NAME (changed file name) by using the ITEM   key and then press the **OPEN** key, when the list of file names is displayed. Select characters from the TABLE to correctly form a new file name up to the external identifier (extension), and press the **ENTER** key to define the new file name. The new file name will be displayed to the right of NEW NAME.

• Entry of file names to be changed and change of file names

Select the file name that you want to rename (current file name) by using the ITEM   key. Press the function key [RENAME] to execute the change of the file name.

f) EJECT ... USB flash drive removal

Before removing USB flash drive from FRA5097, be sure to press the function key [EJECT] and check that the USB flash drive is not accessed, by, for instance, confirming that the access lamp is off.

Be warned that an attempt to remove the USB flash drive without pressing the EJECT button or to remove the USB flash drive when being accessed may destroy the unusable USB flash drive.

 CAUTION

- Those file names that involve Japanese language or those long file names exceeding eight alphanumeric characters + three extensions cannot correctly be displayed due to mutilation. In addition, these files cannot be deleted nor renamed.
 - Subdirectories cannot be treated. In addition, they cannot be deleted nor renamed.
 - Press the [EJECT] button and make sure that the access lamp for the USB flash drive goes off before removing the USB flash drive.
-

4.18 Memory

The FRA5097 is equipped with memories which are to be used for recording/storing measured data.

Types	Battery back-up provision	Memory capacity
Mass memory	No (deleted with power off)	No less than 20,000 points*1
Permanent memory	Yes	No less than 2,000 points
Equalizing memory	No (deleted with power off)	No less than 20,000 points*1

*1: The total capacity of the mass and equalizing memories is no less than 20,000 points of measurement data.

Use the menu [Memory] for recording, storage or deletion to/of memory contents.

[STORAGE]

To store the currently displayed data into memory. Use the function key to select the location of storage.

[MASS STORAGE] : To store in the mass memory



[PERMANENT STORAGE] : To store in the permanent memory

[EQL STORAGE] : To store in the equalizing memory.

The Equalizing function (menu [Measure][BASIC FUNCTION][EQUALIZING]) becomes valid, only when data are stored in this memory (i.e., equalizing memory).

[DELETE MASS DATA]

[DELETE PERMANENT DATA]

To delete the stored content of the master data memory or of the permanent data memory. A list of stored data content will be displayed; move the cursor to the desired data using the ITEM   key and then press the function key [DELETE] to delete the desired data.

Functions of Function keys:

[PREV] : To go back to the previous page

[NEXT] : To go to the next page

[DELETE] : To execute deletion

CAUTION

If you press the function key [DELETE CUR.TAG] while the [MEMORY] window is displayed, the current display is deleted. Once the display has been deleted, it cannot be restored.

4.19 Condition display

Press the **CONDITION VIEW** key to display, in the right-hand half window of the screen, the measurement condition of the graph currently displayed on the LCD screen. At every time you press the key, the condition display is repeated on and off, alternatively. Note that measurement conditions displayed as described here are collateral to individual set of data (i. e., they are a part of individual .DAT files).

CAUTION

Note that the measurement condition displayed when you press the **CONDITION VIEW** key is the condition under which the currently displayed data have been measured, but not the current FRA5097 condition which has been set for measurement.

4.20 Max/min search function

When data marker type is set for graph display, the minimum or maximum value of the vertical axis parameters is searched automatically, the marker is shifted and the computed value displayed. Search is enabled for [Y1-PEAK] (maximum), [Y1-BOTTOM] (minimum), [Y2-PEAK] and [Y2-BOTTOM].

[SEARCH] items have been added to menu [GRAPH]. When menu [GRAPH] [SEARCH] is selected, the function keys indicated in Fig. 5-6 are displayed. Press the key for the desired function and the marker shifts. The function is effective only when menu [GRAPH] [FORMAT] [MARKER TYPE] sets [DATA]. When search is executed, the function display menu extinguishes (extinguish at the top menu by pressing the **CLEAR** key).

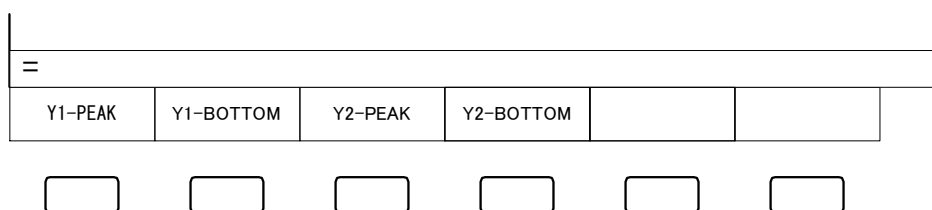

Fig. 4-25 Max/min search function keys

4.21 Other functions

Use the menu [Others] to set the built-in clock, etc.

- [TITLE SET] : To give/set a title to the displayed data. The title given/set will be displayed at the top portion of the graph on the LCD screen and stored with the data.
- [BUZZER] : Set this “ON” to activate the sound of buzzer at every time a message is displayed. Use the menu [Input] to set the buzzer (ON/OFF) to notify the overload status of the input level. Note that you cannot set the buzzer off which buzzes at every key action.
- [DATE SET] : To set the year, month and date.
- [TIME SET] : To set the hour and minute.
- [INITIALIZE] : To initialize all parameters/conditions to be set.
- [SYSTEM] : The FRA5097 software version and options can be checked.

(Blank)

5. Impedance display function

5.1 Overview	5-2
5.1.1 Impedance display	5-2
5.1.2 Open and short correction	5-2
5.2 Operation method	5-3
5.2.1 Impedance display description	5-3
5.2.2 Shunt resistance current-voltage conversion coefficient setting	5-6
5.2.3 Connection for impedance measurement	5-7
5.3 Open and short correction	5-8
5.3.1 Connection for open and short correction data storage	5-8
5.3.2 Data measurement and storage	5-8
5.3.3 Open and short correction data memory	5-9
5.3.4 Open and short correction function setting	5-9

5.1 Overview

5.1.1 Impedance display

Linear and logarithmic graphs display impedance, reactance, admittance, conductance and susceptance. Current to voltage conversion coefficient (0 to 1.0E+6) can also be set.

5.1.2 Open and short correction

This function reduces systematic impedance measurement errors due cable and other factors. Before measuring impedance, the terminals are first measured at open and short states and the resulting data stored in memory. During actual measurement, the resulting open and short data are shown graphically.

To display impedance, set the graph unit to impedance. For details, refer to 4.1.3 Display mode.

5.2 Operation method

5.2.1 Impedance display description

The function displays impedance, resistance, reactance, conductance and susceptance with linear and logarithmic graphs.

In units setting for the impedance and analysis modes CH1/CH2 or CH2/CH1, axis data R, A and B have the following meanings.

R: Impedance (CH1/CH2) or admittance (CH2/CH1)

A: Resistance (CH1/CH2) or conductance (CH2/CH1)

B: Reactance (CH1/CH2) or susceptance (CH2/CH1)

When impedance is displayed, CH1 is fixed to voltage input and CH2 fixed to current input.

To allow 0.01 m to 1 k Ω shunt resistance to be used for current to voltage conversion, [WEIGHTING FACTOR] by the menu [Input] setting range is 0 to 1.0E+6 (resolution 5 digits or 0.1E-09).

Table 5-1 indicates graph axis contents, scale and units with respect to analyze mode and display mode settings.

Table 5-1 Graph axis contents

Analysis mode	Axis Setting	Axis Content	Scale	Unit
CH1/CH2, CH2/CH1, CH1,CH2	logF	Frequency	Log	Hz
	F	Frequency	Linear	Hz
	θ	Phase	Linear	deg
CH1	dBR	Voltage amplitude	Linear	dBV^{*1}
	logR	Voltage amplitude	Log	Vrms
	R	Voltage amplitude	Linear	Vrms
	logA	Real voltage amplitude	Log	Vrms
	log(-A)	Negative real voltage amplitude	Log	Vrms
	A	Real voltage amplitude	Linear	Vrms
	logB	Imaginary voltage amplitude	Log	Vrms
	log(-B)	Negative imaginary voltage amplitude	Log	Vrms
	B	Imaginary voltage amplitude	Linear	Vrms
	-B	Negative imaginary voltage amplitude	Linear	Vrms
CH2	dBR	Ampere amplitude	Linear	dBA^{*2}
	logR	Ampere amplitude	Log	Arms
	R	Ampere amplitude	Linear	Arms
	logA	Real current amplitude	Log	Arms
	log(-A)	Negative real current amplitude	Log	Arms
	A	Real current amplitude	Linear	Arms
	logB	Imaginary current amplitude	Log	Arms
	log(-B)	Negative imaginary current amplitude	Log	Arms
	B	Imaginary current amplitude	Linear	Arms
	-B	Negative imaginary current amplitude	Linear	Arms
CH1/CH2	dBR	Impedance	Linear	$\text{dB}\Omega^{*3}$
	logR	Impedance	Log	Ω
	R	Impedance	Linear	Ω
	logA	Resistance	Log	Ω
	log(-A)	Negative resistance	Log	Ω
	A	Resistance	Linear	Ω
	logB	Reactance	Log	Ω
	log(-B)	Negative reactance	Log	Ω
	B	Reactance	Linear	Ω
	-B	Negative reactance	Linear	Ω
CH2/CH1	dBR	Admittance	Linear	dBS^{*4}
	logR	Admittance	Log	S
	R	Admittance	Linear	S
	logA	Conductance	Log	S
	log(-A)	Negative conductance	Log	S
	A	Conductance	Linear	S
	logB	Susceptance	Log	S
	log(-B)	Negative susceptance	Log	S
	B	Susceptance	Linear	S
	-B	Negative susceptance	Linear	S

*1 : 1 Vrms is assumed to be 0 dBV.

*2 : 1 Arms is assumed to be 0 dBA.

*3 : 1 Ω is assumed to be 0 dB Ω .

*4 : 1 S is assumed to be 0 dBS.

Table 5-2 is added to Table 4-3. Combinations other than indicated in Tables 4-2 and 5-2 are ineffective. If an ineffective combination is designated, the graph is not displayed and the existing displayed graph is deleted. Since the data remain, by designating an effective combination, the graph can again be displayed.

Table 5-2 Display mode list (1) Analysis mode: (CH1) or (CH2)







[DISPLAY MODE]			Display Item			Remark
X axis	Y1 axis	Y2 axis	X axis	Y1 axis	Y2 axis	
$\log F$ F	dBR $\log R$ R	θ —	Frequency	Amplitude	Phase/none	Bode chart
$\log F$ F	θ	—	Frequency	Phase		
$\log F$ F	$\log A$ $\log(-A)$	$\log B$ $\log(-B)$	Frequency	Real amplitude	Imaginary amplitude	
$\log F$ F	A	B	Frequency	Real amplitude	Imaginary amplitude	
θ	dBR $\log R$ R	—	Phase	Amplitude		Nichols chart
A	B	—	Real amplitude	Imaginary amplitude		Nyquist diagram
A	-B	—	Real amplitude	Negative imaginary amplitude		Cole cole plot

Table 5-2 Display mode list (2) Analysis mode: (CH1/CH2) or (CH2/CH1)

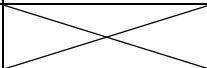
[DISPLAY MODE]			Display Item			Remark
X axis	Y1 axis	Y2 axis	X axis	Y1 axis	Y2 axis	
$\log F$ F	dBR $\log R$ R	θ —	Frequency	Impedance Admittance	Phase/none	Bode chart
$\log F$ F	θ	—	Frequency	Phase		
$\log F$ F	$\log A$ $\log(-A)$	$\log B$ $\log(-B)$	Frequency	Resistance Conductance	Reactance Susceptance	
$\log F$ F	A	B	Frequency	Resistance Conductance	Reactance Susceptance	
θ	dBR $\log R$ R	—	Phase	Impedance Admittance		Nichols chart
A	B	—	Resistance Conductance	Reactance Susceptance		Nyquist diagram
A	-B	—	Resistance Conductance	Negative reactance Negative susceptance		Cole cole plot

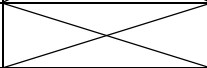
The display items in the Y1 and Y2 axes shown in the above table vary according to the analysis mode and correspond to those described in Table 5-1 Graph axis contents.

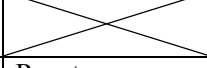
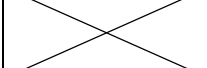
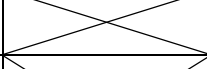
5.2.2 Shunt resistance current-voltage conversion coefficient setting

Use the menu [INPUT] [WEIGHTING FACTOR] to set current-voltage conversion coefficient. Setting range is 0 to 1.0E+6.

Voltage input is CH1. If connecting a preamplifier with a gain of 100, set the CH1 weighting factor to 0.01 (inverse of 100).

Current input is CH2. If the CH2 shunt resistance is 100 m Ω , set the CH2 weighting factor to 10 (inverse of 100 m).

Set invert on to invert the phase (+180°). This can be effective for inverting voltage and current phase when measuring impedance.

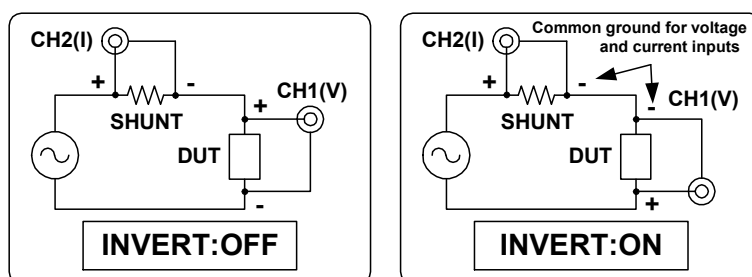

Fig. 5-1 Phase invert connection

5.2.3 Connection for impedance measurement

Apply an AC signal from the internal oscillator to the device under test (DUT). Supply the voltage signal to CH1 and current detect signal to CH2.

A 1 to 100 Ω shunt resistor is suitable for current detection. If measuring a larger voltage and large current, supply the FRA5097 oscillator output to an external amplifier. The NF Corporation HSA series can be used to 300 Vp-p. If the DUT current is large, a current probe (CT) can be used for the detector.

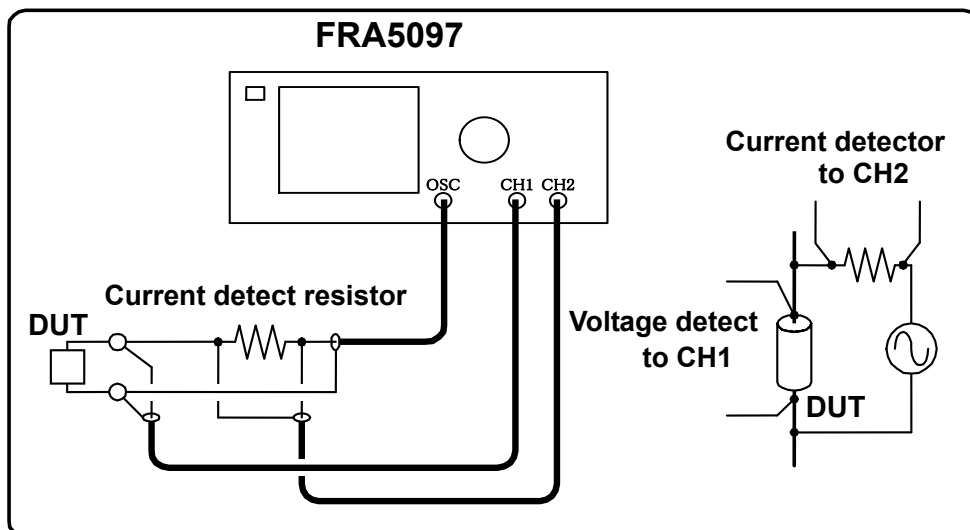

Fig. 5-2 Impedance measurement connection

5.3 Open and short correction

5.3.1 Connection for open and short correction data storage

Although open and short can be simultaneously corrected, these are used separately according to the impedance to be measured.

Short correction: Low impedance (under about 10 Ω)

Open correction: High impedance (above about 1 k Ω)

Connections for storing open and short correction data are indicated in Figs. 5-3 and 5-4.

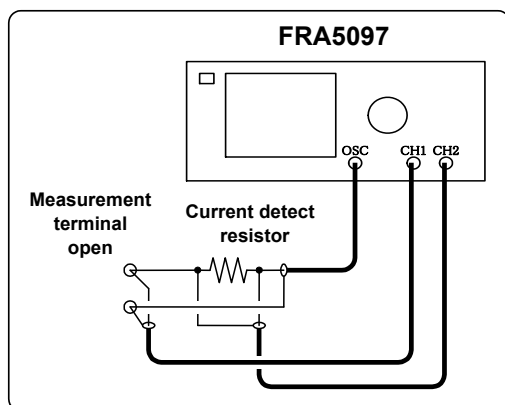

Fig. 5-3 Open correction example

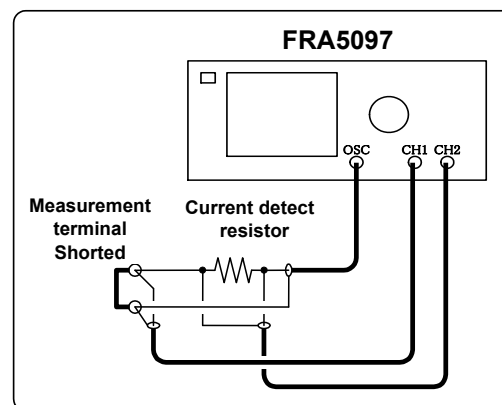

Fig. 5-4 Short correction example

5.3.2 Data measurement and storage

Measure and store the open and short data as follows.

- 1) Set the menu [Measure] [BASIC FUNCTION] [OPEN CORRECTION] and [SHORT CORRECTION] at off.
- 2) Measure the impedance terminal in open state. Use the menu [Memory] to select [STORAGE], and so show the function keys indicated in Fig. 5-5. Press [OPEN STORAGE] to store the open correction in memory.

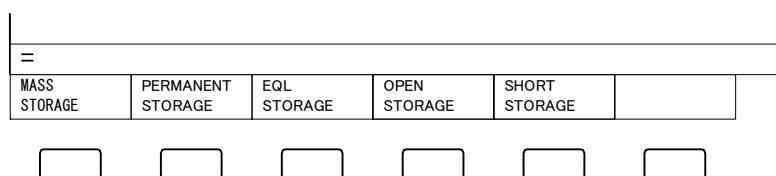

Fig. 5-5 Open and short correction function keys

- 3) Measure the terminal in shorted state and press the [SHORT STORAGE] key to store the short correction data in memory.

Note: Be sure both correction functions are off when measuring the correction data. Measure the DUT at the same frequency range, oscillator amplitude and other conditions as the correction data.

5.3.3 Open and short correction data memory

Battery backup is not used for open and short correction data memory. These data are lost when power is cut and resupplied. Be sure to again enter the data after supplying power.

The capacity sum of the master and equalizer memories corresponds to 20,000 measurements. If large amounts of data are stored in the master memory, the amount available for the correction data is reduced and in some cases may be inadequate. In this event, erase the master memory before storing the correction data.

5.3.4 Open and short correction function setting

The open and short correction function must be set to on in order to conduct measurements using the open and short correction data. Use the menu [MEASURE] [BASIC FUNCTION] [OPEN CORRECTION] and [SHORT CORRECTION] to select and deselect (on and off).

The items can be selected independently. Table 5-4 shows the correction formulas for the item on/off state combinations.

Table 5-4 Open and short correction formulas

Open correction	Short correction	Correction formula
OFF	ON	$Z_x = Z - Z_s$
ON	OFF	$Z_x = Z_p \times Z \div (Z_p - Z)$
ON	ON	$Z_x = Z_p \times (Z - Z_s) \div (Z_p - (Z - Z_s))$

Z_x : Correction computation result

Z : Measurement value

Z_s : Short correction data (CH1/CH2)

Z_p : Open correction function (CH1/CH2)

These formulas apply regardless of the [ANALYSIS MODE].

(Blank)

6. Files

6.1	Overview.....	6-2
6.2	Computer system in which you can read	6-2
6.3	File format.....	6-2
6.3.1	Format of measurement data files	6-4
6.3.2	Format of measurement conditions files	6-7
6.4	Software for reading files.....	6-13
6.4.1	Installation	6-14
6.4.2	Uninstallation.....	6-14
6.4.3	Overview of operations.....	6-15

6.1 Overview

The FRA5097 has a provision of saving, as a file, measurement data and setting conditions in an external memory (USB flash drive). You can read out the content of the saved file through PCs such as IBM PC/AT compatible machines.

This section describes the format of the file produced by the FRA5097.

6.2 Computer system in which you can read

The disk file that has been produced by the FRA5097 can be read out through the following hardware under the following OS (operating system) environment:

- Hardware : IBM PC/AT compatible machines featuring a USB 1.1 or 2.0 port
- OS : MS-Windows 98SE or later

6.3 File format

General aspects of the file of measurement data and measurement conditions produced by the FRA5097 are the following:

- Directory on which files are produced:
 - Files are produced only in the root directory
- Limitation to file naming 8 characters
 - The external identifier (the part indicated by ### in a file name of *****.###) of measurement data files is “DAT”. The external identifier of measurement condition files is “CON”. You can change the type of files to arbitrary ones with appropriate external identifiers by renaming operation. However, the files with the two external identifiers mentioned above are the only ones that can be read in to the FRA5097.
- File attribute
 - The attribute of files produced by the FRA5097 is identical to that of normal files; e.g., they are readable and writable.
- Time and date codes of file directory
 - The “minute”, “hour”, “date”, “month” and “year” written in the file directory are those at which the FRA5097 is creating the file, as measured by its internal clock.

Table 6-1 shows both measurement data and setting conditions as binary files with file content variables and size (number of bytes).

Table 6-1 Data types of variables within file

Types	Size (number of bytes)	Notes
long	4	integer with sign
short	2	integer with sign
double	8	IEEE double precision floating-point number
float	4	IEEE single precision floating-point number
char	–	character type, 1 byte per character

The order of byte alignment is big-endian (higher order bytes are placed earlier according to the order). Note that the byte alignment order is opposite to the data alignment order used for IBM AT/PC compatible machines.

The following shows the formats of the IEEE double and single precision floating-numbers which are used for the FRA5097 file.

■ Format of IEEE double precision floating-point number (8 bytes per data, or set of data)

Leading byte	
seeeeeee	eeeeeeee mmmmmmmmm mmmmmmmmm mmmmmmmmm mmmmmmmmm mmmmmmmmm mmmmmmmmm mmmmmmmmm
MSB	MSB
s: sign of mantissa 0: positive, 1: negative	
e: exponent (11 bits) exp: 0 - 2,047	
m: mantissa (52 bits) mantissa	
Numerical value = $(-1)^s \times 2^{(\text{exp}-1023)} \times (\underline{1} \pm \text{mantissa}/2^{52})$	
where the number "1" that is underlined above should be eliminated when exp = 0.	

■ IEEE single precision floating-point number (4 byte per data, or set of data)

Leading byte	
seeeeeee	emmmmmmm mmmmmmmmm mmmmmmmmm
MSB	MSB
s: sign of mantissa 0: positive, 1: negative	
e: exponent (8 bits) exp: 0 - 255	
m: mantissa (23 bits) mantissa	
Numerical value = $(-1)^s \times 2^{(\text{exp}-127)} \times (\underline{1} \pm \text{mantissa}/2^{23})$	
where the number "1" that is underlined above should be eliminated when exp = 0.	

6.3.1 Format of measurement data files

One file comprises the three following parts: the header, the set parameters and the data.

There are two types of measurement data files: i.e., raw measurement data (RAW data) and operated measurement data (OPERATED data).

RAW data are those which have been obtained through direct measurement by the FRA5097, which may have been processed by equalizing (through menu [Measure][BASIC FUNCTION][EQUALIZING]) and input weighting (through menu [Input][WEIGHTING FACTOR]) functions.

Fig. 6-1 indicates resulting data from FRA5097 computations (arithmetic, differential, integral, open and closed loop, etc.).

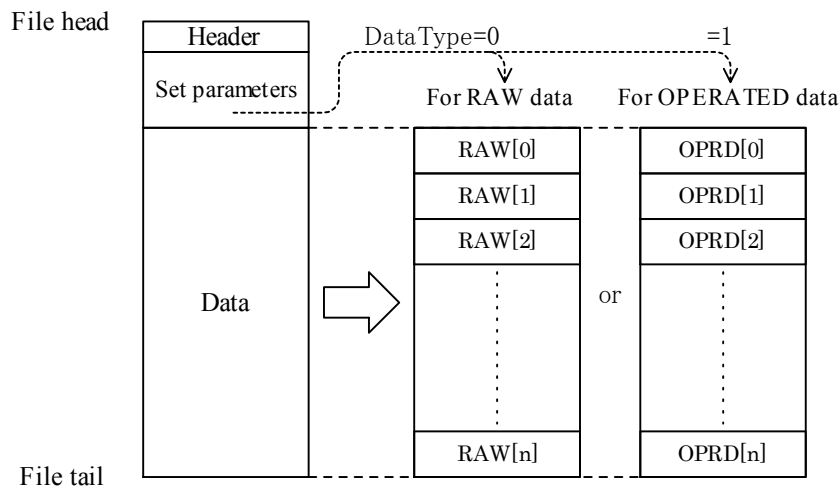

Fig. 6-1 Structure of measurement data file

The file formats of the header, the set parameters and the data are shown in Tables below.

Table 6-2 a) Measurement data file format - Header

Offset	Type	Descriptions (content)
0	long	Offset of leading edge of the data 212
4	long	(Checksum)
8	char[16]	Product type (name) "NF FRA5097 "
24(0x18)	char[8]	File format version "3.00 "
32(0x20)	char[8]	Type of file "DATA "

Table 6-2 b) Measurement data file format - Set parameters

Offset	Type	Descriptions (content)	
40(0x28)	long	(Not yet used)	
44(0x2c)	short	Type of data (data type) 0: RAW data, 1: OPERATED data	
46(0x2e)	short	Number of data (Num)	
48(0x30)	short	Data status 0: not stored 1: stored in mass memory 2: stored in permanent memory	
50(0x32)	short	Year when data are generated: 1970 - 2069	
52(0x34)	short	Month when data are generated: 1 -12	
54(0x36)	short	Day when data are generated: 1 - 31	
56(0x38)	short	Hour when data are generated: 0 - 23	
58(0x3a)	short	Minute when data are generated: 0 - 59	
60(0x3c)	char[64]	Title of data 64 characters maximum	
124(0x7c)	double	Oscillator (OSC) amplitude 0.0 - 10.0	
132(0x84)	double	Oscillator (OSC) bias -10.0 - +10.0	
140(0x8c)	short	Oscillator (OSC) waveform 0:sinusoidal wave, 1:rectangular wave, 2:triangular wave	
142(0x8e)	short	(not yet used)	
144(0x90)	double	Maximum sweep frequency 0.1E-3 - 15E+6	
152(0x98)	double	Minimum sweep frequency 0.1E-3 - 15E+6	
160(0xa0)	short	Type of sweep resolution (Sweep Type) 0:Log steps/sweep 2:Lin steps/sweep 1:Log steps/decade 3:Lin Hz	
162(0xa2)	short	(not yet used)	
		SweepType=0,1,2	
		SweepType=3	
164(0xa4)	short	Sweep resolution (steps)	
166(0xa6)	short[3]	double	Sweep resolution (Hz)
172(0xac)	short	Type of integration (IntegType) 0:cycle, 1:sec	
174(0xae)	short	(not yet used)	
		IntegType=0	
		IntegType=1	
176(0xb0)	short	Number of integrations (cycle)	
178(0xb2)	short[3]	double	Integration time (sec)
184(0xb8)	short	Type of delay (Delay Type) 0:cycle, 1:sec	
186(0xba)	short	(not yet used)	
		DelayType=0	
		DelayType=1	
188(0xbc)	short	Delay period (cycle)	
190(0xbe)	short[3]	double	Delay time (sec)
196(0xc4)	short	Order of harmonics 1 - 10	
198(0xc6)	short	Measurement mode 0:CH1&CH2, 1:CH1&OSC, 2:OSC&CH2	
200(0xc8)	long	Automatic integration function 0:OFF, 1:ON	
204(0xcc)	long	High-density slow sweep function 0:OFF, 1:ON	
208(0xd0)	long	Amplitude compression function 0:OFF, 1:ON	

The file format for the data depends on the types of data (i.e., RAW or OPERATED data). The type of data is specified by the DataType of the offset 44(0x2c) in the set parameter. The first one (point of) data for either of the RAW or OPERATED data (RAW[0] or OPRD[0]) is invalid. The number of data is stored in Num in the offset 46(0x2e) of the set parameter.

Table 6-2 c) Measurement data file format - Data (RAW data)

Offset	Type	Descriptions (content)
212(0xd4)	RAW	Invalid data RAW[0]
240(0xf0)	RAW	RAW[1]
268(0x10c)	RAW	RAW[2]
:	RAW	:
212+28 × Num (0xd4+0x1c × Num)	RAW	RAW[Num]

Table 6-2 d) Measurement data file format - Data (OPERATED data)

Offset	Type	Descriptions (content)
212(0xd4)	OPRD	Invalid data OPRD [0]
228(0xe4)	OPRD	OPRD [1]
244(0xf4)	OPRD	OPRD [2]
:	OPRD	:
212+16 × Num (0xd4+0x10 × Num)	OPRD	OPRD [Num]

The formats for the RAW data (RAW) and the OPERATED data (OPRD) are described in the “Table 6-3 Data format” below. The RAW data (RAW) and the OPERATED data (OPRD) occupy 28 bytes (0x1c) and 16 bytes (0x10), respectively, per data (set).

Table 6-3 a) Data format (RAW measurement data, RAW)

Offset	Type	Descriptions (content)
0	double	Frequency (Hz)
8	float	CH1 voltage (Vrms)
12(0xc)	float	Phase of CH1 with reference to CH2 (deg) -180.0 < phase ≤ +180.0
16(0x10)	float	CH2 voltage (Vrms)
20(0x14)	double	Coherence

Table 6-3 b) Data format (OPERATED measurement data, OPRD)

Offset	Type	Descriptions (content)
0	double	Frequency (Hz)
8	float	Gain
12(0xc)	float	Phase(deg) -180.0 < phase ≤ +180.0

6.3.2 Format of measurement conditions files

One measurement condition file constitutes the header and the condition data. The leading portion of the file is the header, where such information as the file size and the version number of the FRA5097 is written in. The condition data refer to the parameters to be set for measurement by the FRA5097.

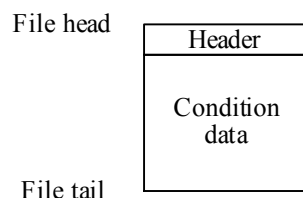

Fig. 6-2 Structure of measurement condition file

The file formats for the header and the condition data are shown in the “**Table 6-4 a) - b) Measurement condition file format**”.

Table 6-4 a) Measurement condition file format - Header

Offset	Type	Descriptions (content)
0	long	File size 4,232
4	long	(Checksum)
8	char[16]	Product type (name) “NF FRA5097 ”
24(0x18)	char[8]	File format version “3.00 ”
32(0x20)	char[8]	Type of file “CON ”

Table 6-4 b) Measurement condition file format - Condition data

Offset	Type	Descriptions (content)
40(0x28)	long	Direction of valid line marker 0:horizontal direction movement, 1:vertical direction movement
44(0x2c)	long	Delta marker ON/OFF 0:normal marker, 1:delta marker
48(0x30)	long	OSC ON/OFF mode 0: Quick, 1: Slow
52(0x34)	long	“REPEAT” lamp 0:off, 1:on
56(0x38)	long	(not yet used)
60(0x3c)	long	Buzzer buzzing at excessive input level (over) 0:OFF, 1:ON
64(0x40)	long	Measurement termination at excessive input level (over) 0:OFF, 1:ON
68(0x44)	long	Oscillator output turned off at excessive input level (over) 0:OFF, 1:ON
72(0x48)	long	Manual sweep 0:OFF, 1:ON
76(0x4c)	long	Equalizing function 0:OFF, 1:ON
80(0x50)	long	Automatic integration function 0:OFF, 1:ON
84(0x54)	long	Amplitude compression function 0:OFF, 1:ON
88(0x58)	long	High-density slow sweep 0:OFF, 1:ON
92(0x5c)	long	Auto-scale 0:OFF, 1:ON
96(0x60)	long	Grid display 0:OFF, 1:ON
100(0x64)	long	Marker display 0:OFF, 1:ON
104(0x68)	long	(not yet used)
108(0x6c)	long	(not yet used)
112(0x70)	long	(not yet used)
116(0x74)	long	(not yet used)
120(0x78)	long	(not yet used)
124(0x7c)	long	(not yet used)
128(0x80)	long	(not yet used)
132(0x84)	long	(not yet used)
136(0x88)	long	Buzzer buzzing 0:OFF, 1:ON
140(0x8c)	long	Open calibration function 0: off, 1: on
144(0x90)	long	Short calibration function 0: off, 1: on
148(0x94)	long	Phase invert 0:off, 1: on
152(0x98)	short	Oscillator (OSC) output wave form 0:sinusoidal waveform, 1:rectangular waveform, 2:triangular waveform
154(0x9a)	short	(not yet used)
156(0x9c)	short	Sweep resolution (Log steps/decade)
158(0x9e)	short	Sweep resolution (Log steps/decade)
160(0xa0)	short	Sweep resolution (Lin steps/sweep)
162(0xa2)	short	Integration period (cycle)
164(0xa4)	short	Delay period (cycle)

Table 6-4 b) Measurement condition file format - Condition data (continued)

166(0xa6)	short	Order of harmonics analysis 1 - 10
168(0xa8)	short	Automatic integration mode 0:SHORT, 1:LONG
170(0xaa)	short	Coherence mode 0:CH1&CH2, 1:CH1, 2:CH2
172(0xac)	short	Maximum integration period for automatic integration
174(0xae)	short	Reference channel for amplitude compression 1:CH1, 2:CH2
176(0xb0)	short	Permissible error for amplitude compression 0 - 100(%)
178(0xb2)	short	Maximum number of trials of amplitude compression 1 - 9,999 (times)
180(0xb4)	short	Compensation factor for amplitude compression 0 - 100(%)
182(0xb6)	short	High-density slow sweep mode 0:MANUAL, 1:AUTO
184(0xb8)	short	Reference channel for high-density slow sweep operation 1:CH1, 2:CH2
186(0xba)	short	Graph style 0:SINGLE, 1:SPLIT
188(0xbc)	short	(not yet used)
190(0xbe)	short	Analysis mode 0:CH1/CH2, 1:CH2/CH1, 2:CH1, 3:CH2
192(0xc0)	short	(not yet used)
194(0xc2)	short	Selection number of mass data
196(0xc4)	short	Selection data for permanent data
198(0xc6)	short	Deletion number of mass data
200(0xc8)	short	Deletion number of permanent data
202(0xca)	short	(not yet used)
204(0xcc)	short	(not yet used)
206(0xce)	short	(not yet used)
208(0xd0)	short	GPIB address 0 - 30
210(0xd2)	short	GPIB delimiter 0:CR/LF^EOI, 1:CR^EOI
212(0xd4)	short	Mass memory number to be saved in USB flash drive
214(0xd6)	short	Permanent memory number to be saved in USB flash drive
216(0xd8)	short	Clock (year) 1970 - 2069
218(0xda)	short	Clock (month) 1 - 12
220(0xdc)	short	Clock (day) 1 - 31
222(0xde)	short	Clock (hour) 0 - 23
224(0xe0)	short	Clock (minute) 0 - 59
226(0xe2)	short	Phase display range 0:±180 deg, 1:0 - 360 deg, 2:-360 - 0 deg
228(0xe4)	short	Type of sweep resolution 0:Log steps/sweep, 1:Log steps/decade, 2:Lin steps/sweep, 3:Lin Hz
230(0xe6)	short	Type of specifying number of integrations 0:period, 1:time
232(0xe8)	short	Type of specifying delay time 0:period, 1:time
234(0xea)	short	Type of automatic integration limit value 0:period, 1:time

Table 6-4 b) Measurement condition file format - Condition data (continued)

236(0xec)	short	Type of VARIATION of high-density slow sweep operation 0:dBR, 1:R, 2:θ, 3:a, 4:b
238(0xee)	short	Measurement mode 0:CH1, CH2, 1:CH1,OSC, 2:OSC,CH2
240(0xf0)	short	Oscillator (OSC) START/STOP phase 0 - 359(deg)
242(0xf2)	short	Type of marker 0:data marker 1:line marker
244(0xf4)	short	(not yet used)
246(0xf6)	short	Oscillator (OSC) STOP mode 0:ZERO, 1:HOLD, 2:PHASE
248(0xf8)	short	Grid type 1:solid line 1:broken line
250(0xfa)	short	Grid mode 0:F, 1:F-R, 2:F-θ, 3:F-R-θ
252(0xfc)	short	Type of DATA1 for the rules of arithmetic 0:DATA TAG, 1:CONSTANT, 2:IMAGINARY
254(0xfe)	short	DATA1 tag set value for the rules of arithmetic 0 - 6
256(0x100)	short	Mode of the rules of arithmetic operation 0: +, 1: -, 2:×, 3:÷
258(0x102)	short	Type of DATA2 for the rules of arithmetic 0:DATA TAG, 1:CONSTANT, 2:IMAGINARY
260(0x104)	short	DATA2 tag set value for the rules of arithmetic 0 - 6
262(0x106)	short	ANSWER tag set value for the rules of arithmetic 0 - 6
264(0x108)	short	DATA TAG set value for differentiation and integration 0 - 6
266(0x10a)	short	Mode of differentiation and integration 0:jω, 1:(jω) ² , 2:1/jω, 3:(1/jω) ²
268(0x10c)	short	ANSWER TAG set value for differentiation and integration 0 - 6
270(0x10e)	short	DATA TAG set value for open- and closed-loop conversion 0 - 6
272(0x110)	short	Type of Tm for open- and closed-loop conversion 0:DATA TAG, 1:CONSTANT
274(0x112)	short	Tm data tag set value for open- and closed-loop conversion 0 - 6
276(0x114)	short	Conversion mode of open- and closed-loop conversion 0:To/(1+To × Tm), 1:Tc/(1-Tc × Tm)
278(0x116)	short	ANSWER TAG set value for open- and closed-loop conversion 0 - 6
280(0x118)	short	(not yet used)
282(0x11a)	short	Auto-sequence mode 0:NON-ACTIVE, 1:RUN MODE, 2:WRITE MODE
284(0x11c)	short	Graph display mode X axis 0:logF, 1:F, 2:θ, 3:A
286(0x11e)	short	Graph display mode Y1 axis 0:dBR, 1:logR, 2:R, 3:θ, 4:logA, 5:log(-A), 6:A, 7:B, 8:-B
288(0x120)	short	Graph display mode Y2 axis 0: θ, 1:logB, 2:log(-B), 3:B, 4:OFF
290(0x122)	short	Display units 0: Gain, 1: Impedance
292(0x124)	short	(not yet used)
294(0x126)	short	Bitmap file name number
296(0x128)	short	External control selection: 0: GPIB, 1: USB
298(0x12a)	short	(not yet used)

Table 6-4 b) Measurement condition file format - Condition data (continued)

300(0x12C)	long[2]	(not yet used)
308(0x134)	double	Oscillator (OSC) frequency (Hz)
316(0x13c)	double	Oscillator (OSC) amplitude set value (V _{peak})
324(0x144)	double	Current oscillator (OSC) amplitude value (V _{peak})
332(0x14c)	double	Oscillator (OSC) DC bias set value (V)
340(0x154)	double	Current oscillator (OSC) bias value (V)
348(0x15c)	double	CH1 excessive (over) level detection level (V _{rms})
356(0x164)	double	CH2 excessive (over) level detection level (V _{rms})
364(0x16c)	double	CH1 WEIGHTING FACTOR 0.0 - 1.0E+06
372(0x174)	double	CH2 WEIGHTING FACTOR 0.0 - 1.0E+06
380(0x17c)	double	Maximum sweep frequency 0.1E-3 – 15E+6
388(0x184)	double	Minimum sweep frequency 0.1E-3 – 15E+6
396(0x18c)	double	Sweep resolution (Hz)
404(0x194)	double	Integration time (sec)
412(0x19c)	double	Delay time (sec)
420(0x1a4)	double	Maximum integration time for automatic integration (sec)
428(0x1ac)	double	Reference level for amplitude compression (V _{rms})
436(0x1b4)	double	Output limiting value for amplitude compression (V _{peak})
444(0x1bc)	double	VARIATION of (dBR) in high-density slow sweep operation (dB)
452(0x1c4)	double	VARIATION of (R) in high-density slow sweep operation (V _{rms})
460(0x1cc)	double	VARIATION of (θ) in high-density slow sweep operation (deg)
468(0x1d4)	double	VARIATION of (a) in high-density slow sweep operation (V _{rms})
476(0x1dc)	double	VARIATION of (b) in high-density slow sweep operation (V _{rms})
484(0x1e4)	double	Display scale initial value : maximum frequency MAX(Hz)
492(0x1ec)	double	Display scale initial value : minimum frequency MIN(Hz)
500(0x1f4)	double	Display scale initial value : dBR MAX(dB)
508(0x1fc)	double	Display scale initial value : dBR MIN(dB)
516(0x204)	double	Display scale initial value : R MAX(V _{rms})
524(0x20c)	double	Display scale initial value : R MIN(V _{rms})
532(0x214)	double	Display scale initial value : θ MAX(deg)
540(0x21c)	double	Display scale initial value : θ MIN(deg)
548(0x224)	double	Display scale initial value : a MAX(V _{rms})
556(0x22c)	double	Display scale initial value : a MIN(V _{rms})
564(0x234)	double	Display scale initial value : b MAX(V _{rms})
572(0x23c)	double	Display scale initial value : b MIN(V _{rms})
580(0x244)	double	DATA1 constant value in real number for the four rules of arithmetic operation
588(0x24c)	double	DATA1 constant value in imaginary number for the four rules of arithmetic operation

Table 6-4 b) Measurement condition file format - Condition data (continued)

596(0x254)	double	DATA2 constant value in real number for the four rules of arithmetic operation
604(0x25c)	double	DATA2 constant value in imaginary number for the four rules of arithmetic operation
612(0x264)	double	Tm constant set value in real number for open- and closed-loop conversion
620(0x26c)	char[12]	Data file name to be loaded
632(0x278)	char[246]	(not yet used)
878(0x36e)	char[12]	All data SAVE file name
890(0x37a)	char[246]	(not yet used)
1136(0x470)	char[12]	Display data SAVE file name
1148(0x47c)	char[246]	(not yet used)
1394(0x572)	char[12]	Condition data SAVE file name
1406(0x57e)	char[246]	(not yet used)
1652(0x674)	char[12]	Measurement data LOAD file name
1664(0x684)	char[246]	(not yet used)
1910(0x776)	char[12]	Condition data LOAD file name
1920(0x780)	char[504]	(not yet used)
2426(0x97a)	char[12]	FILE DELETE file name
2438(0x986)	char[246]	(not yet used)
2684(0xa7c)	char[12]	File name before renaming by FILE RENAME
2784(0xae0)	char[246]	(not yet used)
2942(0xb7e)	char[12]	File name after renaming by FILE RENAME
2954(0xb8a)	char[246]	(not yet used)
3200(0xc80)	char[12]	Mass data SAVE file name
3212(0xc8c)	char[246]	(not yet used)
3458(0xd82)	char[12]	Permanent data SAVE file name
3470(0xd8e)	char[246]	(not yet used)
3716(0xe84)	char[64]	Data title
3780(0xec4)	char[194]	(not yet used)
3974(0xf86)	char[256]	Auto-sequence recording area
4230(0x1086)	char[2]	(not yet used)

6.4 Software for reading files

The software “DSPL5090.EXE”, which has a capability of reading out the file produced by the FRA 5097 and of displaying the read-out data in the form of the Bode diagram on the PC screen can be downloaded from the NF Corporation website at <http://www.ntcorp.co.jp>.

This software operates under Windows95 and up (i.e., this does not operate under Windows3.1 and previous versions to it).

Important functions of this software are the following:

- To read out data files as measured by the FRA5097 from the USB flash drive.
- To store the read-out data in the CSV format file.
- To display the read-out data in the form of Bode diagram in the screen.
- To print (plot) the Bode diagram of the read-out data.

An example is illustrated in the Figure below, where a Bode diagram is shown, which was obtained through the use of DSPL5090, based on the data file saved in a USB flash drive that was originated from the FRA5097 measurement data.

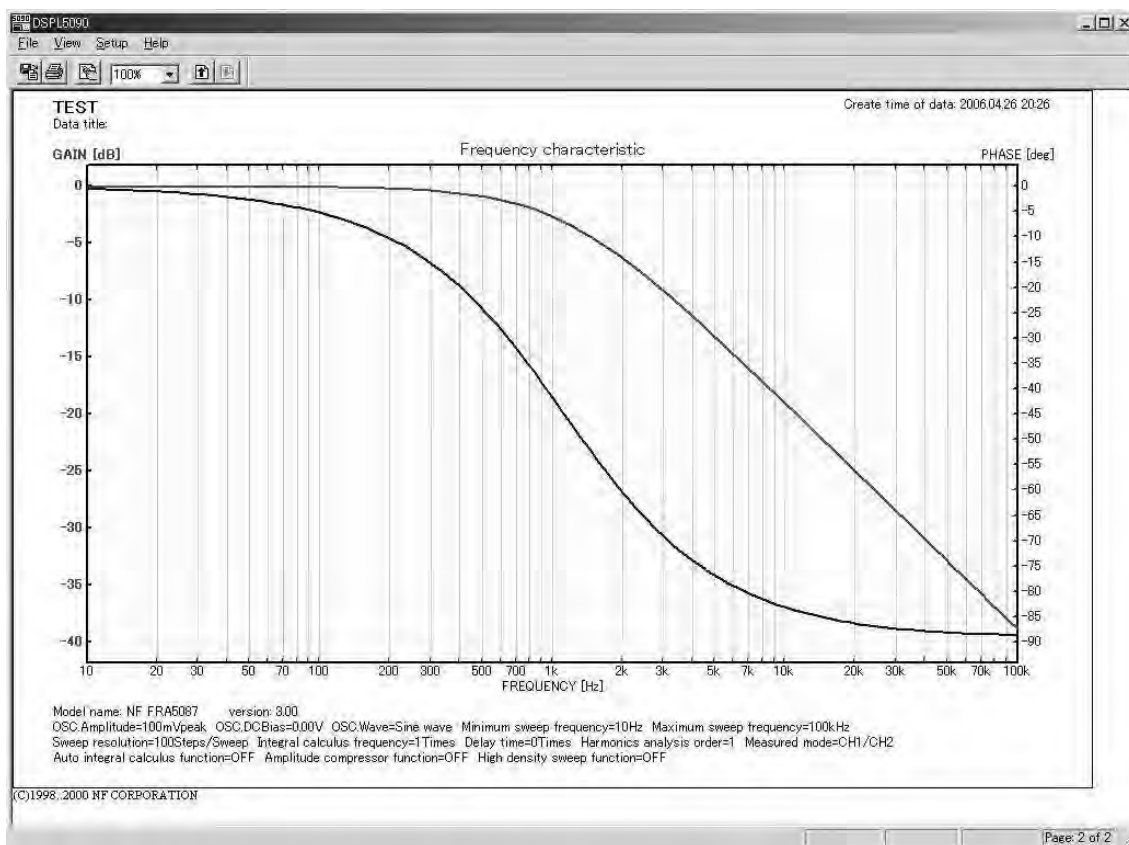

Fig. 6-3 Example of graph display by DSPL5090

6.4.1 Installation

While this software can operate being installed in the floppy disk, it is recommended that you operate the software installed in the hard disk or the network drive, since the latter will provide you with faster operation speed.

a) Preparing folder

Prepare/create a folder such as “C:\Program Files\DSPL5090.CFG”, for example, in the hard disk or the network drive.

b) Software download and extraction

Download the file reading software, "DSPL5090" from our support website (<http://www.nfcorp.co.jp/support/download.html>) to a folder you have created.

Extract the files that are archived in LZH format into the created folder, using appropriate extraction software.

c) Adding to start menu, etc.

Add “DSPL5090.EXE” in the start menu and/or add its shortcut on the desktop, as you need, to more conveniently use the software.

Refer to the instruction manual for Windows for more details on the adding procedure.

6.4.2 Uninstallation

The uninstalling procedure of this software is so structured that you only need to uninstall those folders, files or shortcuts that have been added through the procedure of “**6.4.1 Installation**”.

a) Deleting installation folder and/or software

If the folder that has been prepared for installation involves only the files of “DSPL5090.EXE” and “DSPL5090.CFG”, delete the whole folder. If you have additional files that are needed, delete only the files of “DSPL5090.EXE” and “DSPL5090.CFG”.

b) Deleting added items

Delete those items that have been added to the start menu and the desktop, if any.

6.4.3 Overview of operations

a) Opening file

Use the menu [File][Open data file] or click the  button to open the file.

When the drive or the folder that is displayed to the right of “File name” is not in a form of data file folder, click the  button to display the dialog box “Reference of search path”. Check and confirm here that the right-hand portion of the “File name” is “*.dat”.

Click the “Find” button, when no file names are displayed in spite of data existing in the drive or folder specified.

Click the file name in the list of file names to select the file you want. Click while pressing the “Ctrl” key, when you want to select more than one file.

Click the button “Create graph” to display the graph of the file data.

b) Displaying multiple pages of graphs

When you have specified more than one page of data files, use the menu or the button to change the page.

To the previous page: Use the menu [View][Prev page] or click the  button.

To the next page: Use the menu [View][Next page] or click the  button.

c) Storage of CSV file

Use the menu [File][save operated data...] to store the data of the page currently displayed in the form of text file in the CSV format.

The data occupies one line which has three items separated by commas (frequency [Hz], gain [dB], phase [deg]).

d) Copying to clipboard

Use the menu [File][Copy to clipboard] to copy the graph of the currently displayed page to the clipboard as a bitmap image.

e) Printing graph

Use the menu [File][Print graph] or click the  button to print (or plot) the graph of the file data that have been read in.

Execute [File][Setup printer...] in advance, if necessary.

f) Setting graph format

The format of the graph when the file is opened is in the status of the setting through [Setup][Graph properties(standard)...].

Use the menu [Setup][Graph properties(current)...] or click the  button to change the setting of the format of the currently displayed graph.

Use the menu [Setup][Overwrites as standard value] to change the current format to the standard value.

Use the menu [Setup][Back to standard value] to turn the current format back to the standard value.

7. Trouble shooting

7.1	Error messages	7-2
7.1.1	List of information messages	7-2
7.1.2	List of error messages	7-3
7.2	Quick diagnosis.....	7-7

7.1 Error messages

The FRA5097 outputs two types of messages, information messages and error messages. Either type of messages is displayed in the center of the screen when needed, information messages being surrounded by the blue frame and error messages being surrounded by the red frame. In event of FRA5097 error, controller can also be notified via GPIB and USB flash drive.

7.1.1 List of information messages

No.	Messages	Descriptions
0	All setups and data were lost, re-initialized	All data have been lost at the time of power supply switching on, and therefore re-initialization has been made.
1	Analysis frequency is limited to 15MHz	Analysis frequency is limited to 15 MHz. Note that, even if the order of frequency harmonics is more than one (1), analysis frequency is still limited to 15 MHz.
2	Some parameters were corrected	When condition file is read, since some values cannot be set, several parameters were initialized. Use for checking actual settings.
3	ALL CONDITIONS WILL BE REPLACED! CONTINUE?	Simple condition will be loaded. Continue?
4	CONDITION DATA ON USB MEMORY WILL BE REPLACED! CONTINUE?	Simple condition will be saved. Continue?
5	USB IF is not available. Please select with OUTPUT-SELECT menu.	The external interface is set to GPIB. To use the FRA5097 with the USB interface, set the external interface to USB.
6	GPIB IF is not available. Please select with OUTPUT-SELECT menu.	The external interface is set to USB. To use the FRA5097 with the GPIB interface, set the external interface to GPIB.

7.1.2 List of error messages

No.	Messages	Descriptions
1	Data number not found	The data number for the mass data or the permanent data specified cannot be found.
2	Storage memory overflow	The storage area cannot be secured in the permanent memory.
3	Storage memory overflow	The storage area cannot be secured in the mass memory.
4	No data to be stored	No data exist to be stored.
5	Data is already stored	The specified data have already been stored in the mass memory.
6	Disk not found	A USB flash drive is not connected.
7	Disk is write-protected	Since the USB flash drive is write-protected, it is not possible to write in it.
8	Can't access disk	The USB flash drive cannot be accessed. There are errors in the directory area of the USB flash drive. For example: <ul style="list-style-type: none"> • The USB flash drive is not formatted. • The USB flash drive is in different format. • The USB flash drive is damaged. • The file is damaged.
9	Disk overflow	The USB flash drive capacity is insufficient for storage.
10	File not found	The specified file cannot be found.
11	Storage memory overflow	The memory capacity is insufficient for storage.
12	No data to be saved	No data exist which are to be saved.

No.	Messages	Descriptions
13	Can't load, file corrupted	The file is corrupted or is not correct, and therefore it cannot be loaded.
14	Can't save during acquisition	Data is still in acquisition phase, and therefore they cannot be saved.
15	Amplitude compression failure	Designated amplitude could not be set. Refer to oscillator maximum output level and amplitude variations, and review settings.
16	Storage area overflow	Memory capacity is not sufficient for storage and overflow has occurred. Measurement data cannot be stored anymore.
17	Can't set, range is too narrow	The sweep range which you are trying to set is narrower than the frequency resolution capability. You may not set this sweep range.
18	Can't set, line markers are invalid	Since the line markers in the y-axis direction are invalid for the sweep range that you are setting, you may not set the sweep range by using the line markers.
19	Can't set, markers aren't displayed	Since markers are not displayed, you may not set what you are trying to do.
20	Can't measure, analysis frequency is over limit	Analysis frequency is over 15 MHz which is the upper limit, and therefore, measurement cannot be done.
21	Can't set, line markers are invalid	Since the line markers in the y-axis direction are invalid for the sweep range that you are setting, you may not set the sweep range by using the line markers.
23	Missing file name	The file name is missing.
24	Duplicate file name	Duplicated file names have been found.

No.	Messages	Descriptions
25	Invalid file name	The file name is invalid.
26	Illegal header	An illegal header has been found in the program code.
27	Illegal parameter	An illegal parameter has been found in the program code.
28	Parameter out of range	The numerical value of the parameter has been found to be out of the permissible range.
29	Too many parameters	The number of parameters in the program code exceeds the upper limit.
30	Too few parameters	The number of parameters in the program code exceeds the lower limit.
31	Question not permitted	The current header cannot be used for asking a question, and can only be used for setting.
32	Question only permitted	The current header cannot be used for setting, and can only be used for asking a question.
33	No data in this tag	There are no data existing in the specified tag, and therefore, no data can be read out.
34	Byte count miss mach	The data cannot be received, since the number of bytes of the binary data is not the same as that of the data to be received.
35	Not enough memory	The memory capacity is insufficient to store the received or transmitted data.
36	This data block is currently locked	The data block with the specified tag is now under operation and currently locked, and therefore, cannot be transferred.
37	No axis in this axis mode	The specified axis does not exist in the current display mode.
38	GPIB bus error	The GPIB error, where the handshake lines on the GPIB bus do not match to each other.

No.	Messages	Descriptions
40	Can't execute during calibration	Execution cannot be done since calibration is being done.
41	Duplicate tag number	The tag number is duplicated.
42	Can't set Stop Phase while OSC is on	The "Stop Phase" cannot be set since the oscillator (OSC) is in the state of "AC/DC OFF".
43	Can't execute during acquisition or calibration	Execution cannot be done since either calibration or data acquisition is being done.
44	Can't set, graph isn't being displayed	Setting cannot be done, since the graph is not displayed.
45	Can't execute while OSC is on	Calibration cannot be executed, since the oscillator (OSC) is not in the state of "AC/DC OFF".
50	Memory overflow	The memory capacity is not sufficient to secure the required area for calculation operation.
51	Can't execute during measurement	Calculation cannot be executed since measurement is being done.
52	No data in this tag	There are no data existing in the specified tag, and therefore, no data can be read out.
53	Calculation overflow	Overflow occurred for calculation operation.
60	Memory overflow	The memory capacity is insufficient to secure the area required for "auto-sequence" operation.
61	Sequence buffer overflow	The sequence buffer memory has overflowed, its capacity being insufficient.
62	Discontinue to record sequence	Recording of the sequence has been discontinued.
70	Printer timeout	The printer does not respond.

7.2 Quick diagnosis

If you find anything wrong with operations of the instrument, try the following quick diagnoses and measures. If the operations cannot be recovered after the measures taken, contact NF Corporation or one of its representatives.

Failure mode	Possible cause	Quick measure
The instrument does not operate as indicated in the Instruction Manual.	Initialization has not been done.	Description presumes settings were initialized. Select menu [Others], [INITIALIZE] and press [START] to initialize.
Power supply cannot be "on".	The power supply used is not in conformance with the specified ratings.	Use the power supply within the specified ratings.
	The operation is not normal due to external noise, etc.	Reinstall the instrumentation at a location with less noise/ good environment.
Panel operation does not work.	The setting is in the "Remote" status.	Press the GPIB LOCAL key to set the status at the LOCAL mode.
	Keys and/or knobs have been deteriorated.	Contact NF Electronic Instruments to ask repair.
Settings through GPIB cannot be done.	The address is different from that in the program.	Set the address again so that it is identical to that in the program.
	The address used is duplicated with that of other equipment.	Set the address again so that it does not coincide with that of other equipment.
Printing cannot be done.	Printing paper is out.	Install a new roll of printing paper.
Calibration errors occur.	Measurement accuracy has been degraded due to external noise.	Disconnect the signal cables (oscillator output and analysis input cables) and calibrate again. Install the instrument in quiet environment far from noise sources.

(Blank)

8. Maintenance

8.1	Introduction	8-2
8.2	Daily maintenance	8-2
8.3	Storage, re-packaging and transportation	8-3
8.4	Identification of version number.....	8-3
8.5	Performance test	8-4
8.5.1	Test equipment	8-4
8.5.2	Pretest preparations.....	8-4
8.5.3	Oscillator output frequency accuracy	8-5
8.5.4	Oscillator output amplitude accuracy.....	8-6
8.5.5	Oscillator distortion.....	8-7
8.5.6	Oscillator output DC bias accuracy.....	8-8
8.5.7	Analyzer IMRR.....	8-9
8.5.8	Analyzer dynamic range	8-10
8.5.9	Analyzer measuring error frequency response	8-11

8.1 Introduction

Maintenance is essential for you to use the instrument under the good working condition.

This chapter describes the following tips and notices related to maintenance:

- Storage of instrument when it will not be used for a long period of time.
- Notes on repackaging and transportation of the instrument, when the instrument is to be transported.
- Performance tests for preventive maintenance and acceptance testings.

If you find anything wrong with functions or operations of the instrument, or if performance test results do not meet the specifications, contact NF Corporation for repair. In doing so, inform NF Corporation of the outcome of your diagnosis and/or of the performance test results, so that the company could more quickly respond to your requests.

8.2 Daily maintenance

When you find the surface of the instrument panel or cabinet to be dirty, wipe it with a soft cloth. When it is extremely dirty, apply neutral detergent to the cloth, wring the cloth firmly and use it to wipe the instrument surface. Never use such solvent as thinner or benzine, or chemically treated towels, to wipe the instrument surface, since the surface treatment might be altered and/or its painting might be damaged.

8.3 Storage, re-packaging and transportation

a) Storage for a long period of time (when you do not plan to use the instrument for a long time in future)

- Remove the power supply cable from both the instrument connector and the power source outlet.
- Store the instrument at a dirt-free location such as on a safe shelf or in an equipment rack, where nothing could drop down from higher place to hit the instrument.
If the instrument is subject to dirt, cover the instrument with a proper sheet.
- Maintain the temperature and humidity of the storage location within the following range:
Temperature: -10 - +50°C
Humidity: 5 - 95%RH (Absolute humidity is 1 to 29 g/m³, avoid dew condensation.)
- The instrument storage location shall not be such a place as having direct sunlight, near the fire or heat source, or having wide ranges of temperature variation during storage period. The instrument could be deformed or damages could be induced due to such environment.
- The instrument shall not be stored being exposed to corrosive gas, moisture, dust or dirt. The high humidity shall also be avoided for the instrument storage. The instrument could be corroded or damages could be induced due to such environment.

b) Re-packaging for transportation

Observe the following when you re-pack the instrument for transportation, etc.:

- Enclose the whole cabinet involving the instrument so that the surface is protected against potential damages and that thin dust does not get into the inside of the instrument.
- Use a box with appropriate strength and also with appropriate size margin.
- Use buffer materials for packaging so that all the six external faces of the instrument body can be protected.
- Notify by all means to the shipping agent that the instrument inside is a precision machine, when you order shipping.

8.4 Identification of version number

— (Software options are displayed, if they exist)

TABLE
FRA5097 – Version <u>*. **</u> - Standard Version. — http://www.nfcorp.co.jp Copyright 1989..2006 NF Corporation

Press menu, [Others], [SYSTEM] to show above window. Version appears in window at bottom line.

Note that the version number might not always be the same even if the instrument bears the identical type number. Since different version numbers can mean different operations or functions, inform the agent of the version number together with the failure symptom, when you find anomalies and request repair.

8.5 Performance test

This section describes, among principal test items, those items which can be tested without using special/elaborate jigs or measurement equipment. Adjustment and/or repair is needed when you have any test results that do not meet the specifications.

Ask NF Corporation for more detailed tests, calibrations and/or repairs.

8.5.1 Test equipment

The following test equipment and cables are required for performance tests:

- Frequency counter: Accuracy: 1×10^{-6} or better
- Multi-meter (the following measurement shall be possible):
 - AC voltage: Accuracy: ± 0.1 % for 100 mV - 10 V and 100 Hz - 10 kHz.
 - DC voltage: Accuracy: ± 0.1 % for 100 mV - 10 V
- Wideband multi-meter (the following measurement shall be possible):
 - AC voltage: Accuracy: ± 0.5 % for 100 mV - 10 V and 100 kHz - 200 kHz
 - Accuracy: ± 1 % for 100 mV - 10 V and 200 kHz - 1 MHz
 - Accuracy: ± 5 % for 100 mV - 10 V and 1 MHz - 15 MHz
- Distortion meter: 0.1 % or better for full-scale
- Others: BNC-BNC coaxial cable, T-type divider, etc.

8.5.2 Pretest preparations

a) Confirmation of test environment

Perform the test under the following conditions:

- Ambient temperature: +18 - +28 °C Ambient humidity: 25 - 75 %RH
- Power supply voltage: 90 - 132 VAC or 180 - 250 VAC

b) Confirmation of functions/operations

Check and confirm important functions, before the test, in an abbreviated manner according to “2.4 Quick function checking”.

c) Warm-up

Leave the instrument for at least one (1) hour after turning the power on so that the internal temperature becomes stabilized.

Perform/execute calibration by all means before the test. The performance of the FRA5097 is specified on the basis of the status right after calibration.

8.5.3 Oscillator output frequency accuracy

The test of oscillator frequency accuracy is described in this paragraph.

a) Setting

FRA5097		Frequency counter	
Output waveform	sinusoidal wave	Gate time	10 sec.
Output voltage			
AC:	1 V _{peak}		
DC bias:	0 V		

b) Connection

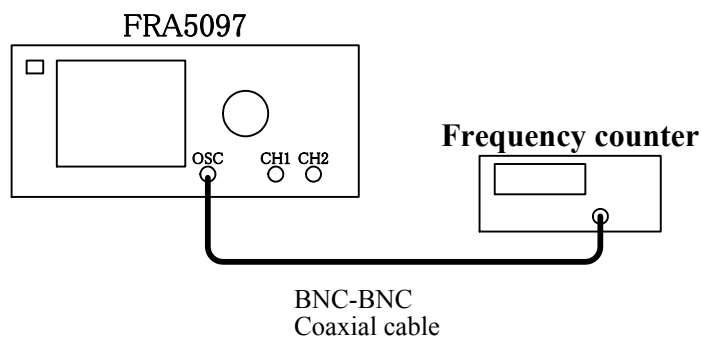

c) Procedure

Set the oscillator output frequency at the following and read the indication of the frequency counter:

Oscillator output frequency: 100 kHz

d) Result and judgment

Oscillator frequency	Frequency counter	Permissible range
100 kHz	_____ kHz	99.9990 - 100.0010 kHz

8.5.4 Oscillator output amplitude accuracy

The oscillator output amplitude and frequency response are tested.

a) Setting

FRA5097		Multi-meter	
Output waveform	sinusoidal wave	Measurement mode	AC voltage (True RMS)
Output voltage			
AC	10 V _{peak}		
DC bias	0 V		

b) Connection

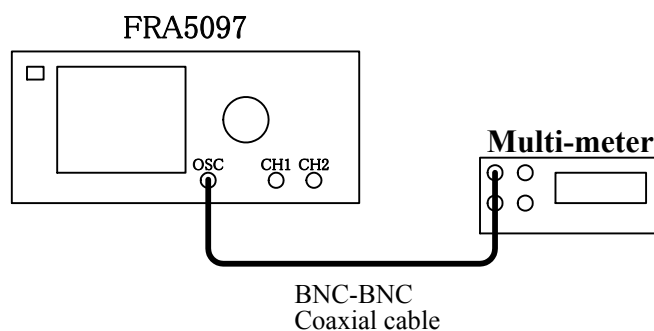

c) Procedure

Set the oscillator frequency as follows and read the multi-meter indications. Use a wideband multi-meter for frequencies above 100 kHz.

Oscillator frequency: 1 kHz, 100 kHz, 1 MHz, 15 MHz

Derive the amplitude from the multi-meter indication by the following formula.

$$[\text{Amplitude accuracy (dB)} = 20 \times \log_{10}[\text{multi-meter indication (V}_{\text{rms}})] - 16.9897$$

d) Judgment

Oscillator frequency	Multi-meter	Amplitude accuracy	Tolerance range
1 kHz	_____ V _{rms}	_____ dB	-0.3 – +0.3 0dB
100 kHz	_____ V _{rms}	_____ dB	-0.3 – +0.30 dB
1 MHz	_____ V _{rms}	_____ dB	-1.00 – +1.00 dB
15 MHz	_____ V _{rms}	_____ dB	-3.00 – +3.00 dB

8.5.5 Oscillator distortion

Oscillator sinewave distortion is tested.

a) Setting

FRA5097		Distortion meter	
Output waveform	Sinusoidal wave	Noise distortion (THD) measuring mode	
Output voltage			
AC	10 V _{peak}		
DC bias	0 V		

b) Connection

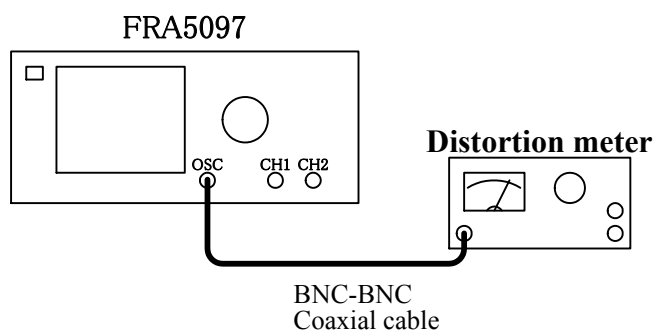

c) Procedure

Set the oscillator frequency as follows and read the distortion meter indication. Set the distortion meter lowpass filter (LPF) to 100 kHz.

Oscillator frequency: 10 kHz

d) Judgment

Oscillator frequency	Distortion (THD)	Tolerance
10 kHz	_____ %	< 0.2 %

THD: Total harmonic distortion

8.5.6 Oscillator output DC bias accuracy

The oscillator output DC bias accuracy is tested.

a) Setting

FRA5097		Multi-meter	
Output waveform	Sinusoidal wave	Measuring mode	DC voltage
Output voltage	AC		
	0 V _{peak}		

b) Connection

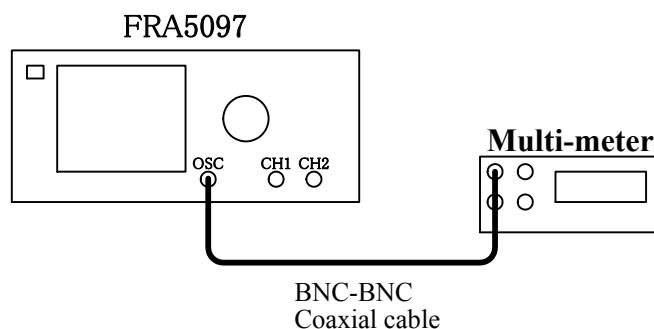

c) Procedure

Set the oscillator DC bias as follows and read the multi-meter indication.

Oscillator DC bias: -10, 0, +10 V

d) Judgment

Oscillator DC bias	Multi-meter	Tolerance
-10 V	_____ V	-10.130 to -9.870 V
0 V	_____ V	-30.0 to +30.0 mV
+10 V	_____ V	+9.870 to +10.130 V

8.5.7 Analyzer IMRR

IMRR at 60 Hz is tested.

a) Setting

FRA5097 oscillator		FRA5097 analyzer	
Frequency	60 Hz	Integration	100 cycles
Output waveform	Sinewave	Measuring mode	CH1, CH2
Output voltage		Display mode	X axis : logF
AC	10 V _{peak}		Y1 axis : dBR
DC bias	0 V		Y2 axis : θ

b) Connection

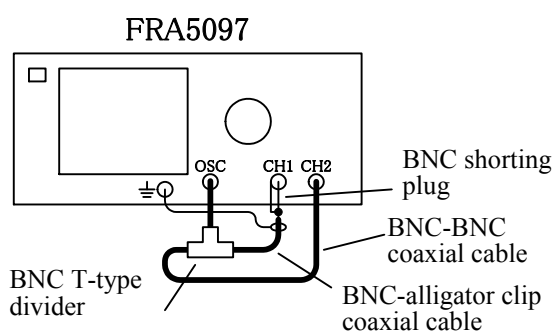

CH1 IMRR measurement

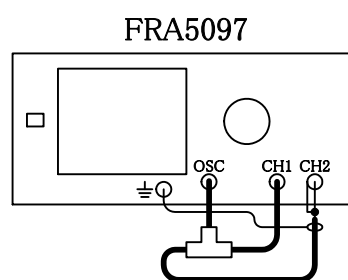

CH2 IMRR measurement

c) Procedure

Set the analyzer mode as follows. Conduct Single measurement with FRA5097.

Read the dBR measuring results from the LCD screen.

Analyzer mode for CH1 IMRR measurement: CH2/CH1

Analyzer mode for CH2 IMRR measurement: CH1/CH2

d) Judgment

Connection	Measured value	Tolerance
CH1 (analyzer mode: CH2/CH1)	dBR=_____dB	More than 120 dB
CH2 (analyzer mode: CH1/CH2)	dBR=_____dB	More than 120 dB

8.5.8 Analyzer dynamic range

The dynamic range is tested.

a) Setting

FRA5097 oscillator		FRA5097 analyzer	
Sweep upper limit frequency	15 MHz	Integration	2,000 cycles
Sweep lower limit frequency	10 Hz	Measuring mode	CH1,CH2
Output waveform	Sinewave	Display mode	X axis : logF Y1 axis: dBR
Output voltage			
AC	10 V _{peak}		
DC bias	0 V		

b) Connection

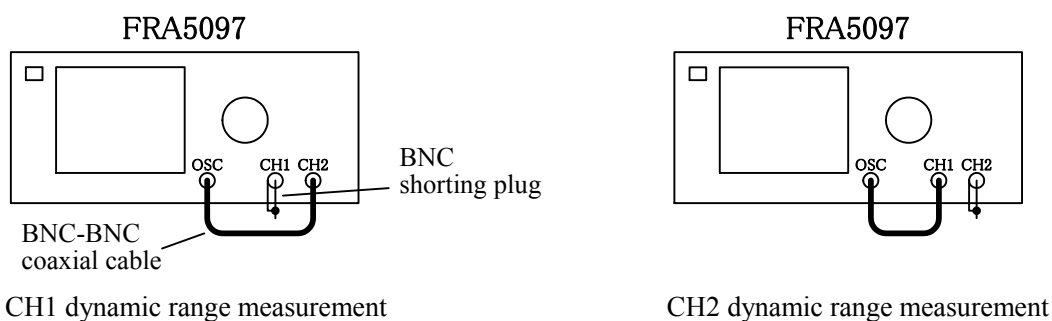

c) Procedure

Set the analyzer mode as follows and sweep with the FRA5097.

Read the minimum dBR measuring results from the LCD screen.

Analyzer mode for measuring CH1 dynamic range: CH2/CH1

Analyzer mode for measuring CH2 dynamic range: CH1/CH2

d) Judgment

Connection	Minimum measured value	Tolerance
CH1 (10 Hz to 1 MHz)	dBR=_____dB	140 dB typ
CH2 (10 Hz to 1 MHz)	dBR=_____dB	140 dB typ
CH1 (1 MHz to 15 MHz)	dBR=_____dB	80 dB typ
CH2 (1 MHz to 15 MHz)	dBR=_____dB	80 dB typ

8.5.9 Analyzer measuring error frequency response

Frequency dependence of the CH1/CH2 measurement value at 100 mV_{peak} output is tested.

a) Setting

FRA5097 oscillator		FRA5097 analyzer	
Sweep upper limit frequency	15 MHz	Integration	50 cycles
Sweep lower limit frequency	10 Hz	Measuring mode	CH1, CH2
Output waveform	Sinewave	Analyzing mode	CH1/CH2
Output voltage		Display mode	X axis : logF
AC	100 mV _{peak}		Y1 axis : dBR
DC bias	0 V		X2 axis : θ

b) Connection

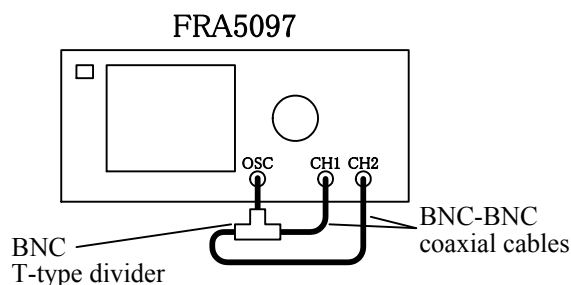

c) Procedure

Use FRA5097 for sweep measurement.

Read the absolute maximum measured results for dBR and θ for frequency ranges up to 20 kHz, 500 kHz, 2.2 MHz and 15 MHz from the LCD screen.

d) Judgment

Frequency range	Measured value	Tolerance
10 Hz to 20 kHz	_____ dB	-0.05 to +0.05 dB
	_____ deg	-0.3 to +0.3 deg
20 kHz to 500 kHz	_____ dB	-0.1 to +0.1 dB
	_____ deg	-0.5 to +0.5 deg
500 kHz to 2.2 MHz	_____ dB	-1.0 to +1.0 dB
	_____ deg	-2.0 to +2.0 deg
2.2 MHz to 15 MHz	_____ dB	-2.0 to +2.0 dB
	_____ deg	-5.0 to +5.0 deg

(Blank)

9. Specifications

9.1	Oscillation section	9-2
9.2	Analysis section input	9-4
9.3	Measurement process	9-7
9.4	Analysis process	9-10
9.5	Calculations	9-10
9.6	Auto sequence	9-10
9.7	Display	9-11
9.8	Memory	9-12
9.9	External memory	9-12
9.10	Peripheral input/output functions	9-13
9.11	Impedance display function.....	9-14
9.12	Miscellaneous specifications	9-15

9.1 Oscillation section

- Number of output channels 1 channel
- Connector Insulated BNC connector
- Output waveform Sine wave/rectangular wave/triangular wave
- Frequency
 - Range 0.1 mHz to 15 MHz (In the case of rectangular or triangular wave, be sure to use at 100 kHz or below. The waveform quality degrades above 100 kHz.)
 - Setting resolution 0.1 mHz (Resolution is 1 mHz at 10 MHz or higher.)
 - Accuracy ± 10 ppm
- AC amplitude
 - Range 0 V to 10 V_{peak} (under no load)
 - Setting resolution 3 digits or 0.01 mV_{peak}, whichever is greater
 - Accuracy (sine wave) Within ± 0.3 dB (100 kHz or below)
 Within ± 1 dB (1 MHz or below)
 Within ± 3 dB (15 MHz or below)
 (The above assumes a calibration was performed shortly prior, and that the setting is between 100 mV to 10 V_{peak}.)
 - Distortion (sine wave) No more than 0.2 % (when 100 kHz or below, BW 500 kHz, and 10 V_{peak} output)
- DC bias
 - Range -10 V to 10 V (under no load)
 - Resolution 10 mV
 - Accuracy $\pm (1 \% \text{ of DC bias setting} + 2 \% \text{ of AC amplitude setting} + 30 \text{ mV})$
 (This value is applicable if a calibration was done shortly prior/)
- Output impedance 50 $\Omega \pm 2$ % (when 1 kHz) Unbalanced (BNC connector plug)
- Maximum output (AC+DC)
 - Voltage ± 10 V (no load)
 - Current ± 100 mA
- Output control
 - QUICK (instantly changes to the set voltage or to 0 V)
 - SLOW (gradually increases/decreases until reaching the set voltage or 0 V)
 - Phase control (The oscillation start/stop phase can be set by one degree increments.)
 - AC and DC can be simultaneously turned ON/OFF, while AC can be independently turned OFF.

-
- Frequency sweep
 - Sweep range 0.1 MHz to 15 MHz
 - Sweep density
 - Log sweep : 3 to 20,000 steps/sweep or 1 to 20,000 steps/decade
(Note 3 steps sweep minimum, 20,000 steps/sweep maximum)
 - Linear sweep : 3 to 20,000 steps/sweep or 0.1 to 15 MHz
(Note 3 steps sweep minimum, 200,000 steps/sweep maximum)
 - Isolation
 - Withstand voltage 250 Vrms continuous (between signal/ground - enclosure)
250 Vrms continuous (between signal/ground - analysis section input)
This value applies when the accompanying BNC cable is being used.
30 Vrms continuous applies when a cable other than the accessory cable is used.
 - Against-enclosure capacity No more than 250 pF
 - Measurement category I, maximum transient voltage 1,500 Vrms

9.2 Analysis section input

- Number of output channels 2 channels
- Connector Insulated BNC connector
- Input impedance $1\text{ M}\Omega \pm 2\%$, parallel $25\text{ pF} \pm 5\text{ pF}$
- IMRR (isolation mode removal ratio)
 - 120 dB or above (DC up to 60 Hz)
 - This value applies when the signal source impedance is smaller than $1\ \Omega$.
- Isolation
 - Withstand voltage
 - 250 Vrms continuous (between signal/ground - enclosure)
 - 250 Vrms continuous (between signal/ground - analysis section input, between the analysis section channels)
 - This value applies when the accessory BNC cable is being used.
 - 30 Vrms applies when a cable other than the accessory cable is used.
 - Against-enclosure capacity No more than 200 pF
- Measurement category I, maximum transient voltage 1,500 Vrms
- Frequency range 0.1 mHz to 15 MHz
- Maximum input voltage
 - 250 Vrms (AC) or $\pm 200\text{ V}$ (DC) alternatively $\pm 350\text{ V}_{\text{peak}}$ (AC + DC)
 - This value applies when accessory BNC cable is used
 - When a cable other than the accessory cable is used, 30 Vrms (AC), or $\pm 60\text{ V}$ (DC) alternatively $\pm 42\text{ V}_{\text{peak}}$ (AC + DC)
- Maximum measurement voltage
 - 250 Vrms
 - This value applies when the accessory BNC cable is being used.
 - 30 Vrms applies in case a cable other than the accessory cable is used.
- Over detection
 - Setting range 0 to 250 Vrms
 - Setting resolution 3 digits
 - Processes
 - Over lamp lights
 - Warning sound (can be turned ON/OFF)
 - Sweep abort (can be enabled/disabled)
 - Oscillator OFF (can be enabled/disabled)
- Harmonic measurement 2nd to 10th (highest frequency of the harmonics is 15 MHz)
- Harmonic and noise rejection ratio
 - Normal mode DC 60 dB or above
 - Broadband white noise 50 dB or above (noise bandwidth 500 kHz, integration of 1,000 cycles)
 - Harmonic (10th and below)
 - 60 dB or above (analysis frequency 100 kHz or below)
 - 40 dB or above (analysis frequency 100 kHz or below)
- Dynamic range
 - 140 dB typ (10 Hz to 1 MHz)
 - 80 dB typ. (above 1MHz, no more than 15 MHz)
 - (This value applies when the bigger of the channel inputs is at least $10\text{ V}_{\text{peak}}$, with an integration of 4,000 cycles)
- Input weight 0 to $1.0\text{E}+6$ (resolutions 5 digits or $0.01\text{E}-9$)

Figure 9-1 indicates the isolation voltage specifications between the oscillating section (OSC)/analysis section inputs (CH1 and CH2) and the enclosure.

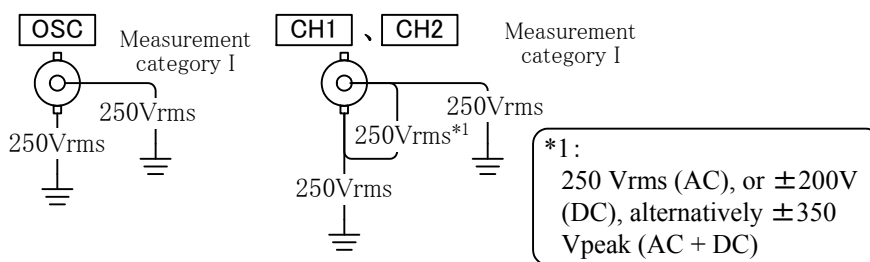

Fig. 9-1 From-enclosure isolation voltage specifications (when accompanying BNC cable is used)

Figure 9-2 indicates the isolation voltage specifications when a cable other than the accompanying cable is being used.

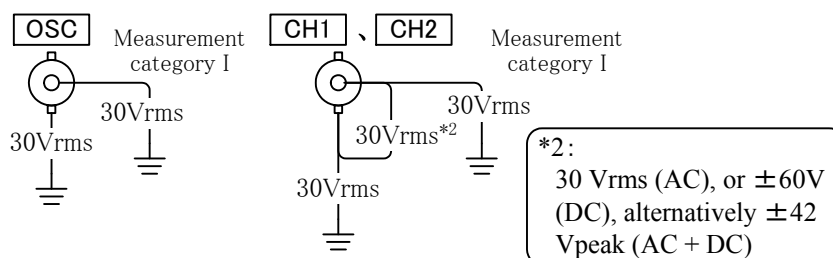

Fig. 9-2 From-enclosure isolation voltage specifications (when a cable other than the accompanying cable is used)

Figure 9-3 indicates the isolation voltage specifications between each of the oscillating section (OSC) and analysis section inputs (CH1 and CH2) when the accompanying BNC cable is being used.

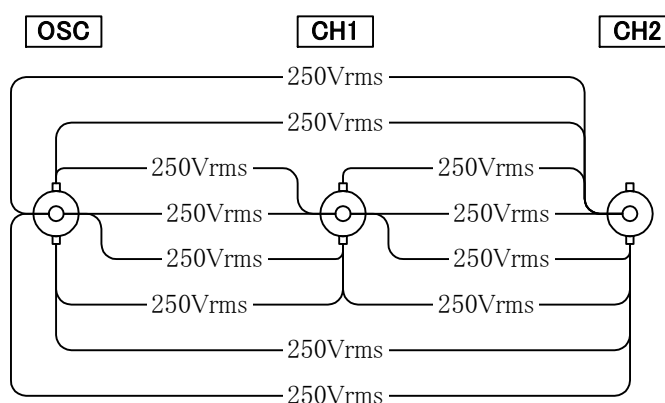

Fig. 9-3 Oscillation section input - analysis section input isolation voltage specifications (when accompanying BNC cable is used)

Figure 9-4 indicates the isolation voltage specifications between each of the oscillating section (OSC) and analysis section inputs (CH1 and CH2) when a cable other than the accompanying cable is being used.

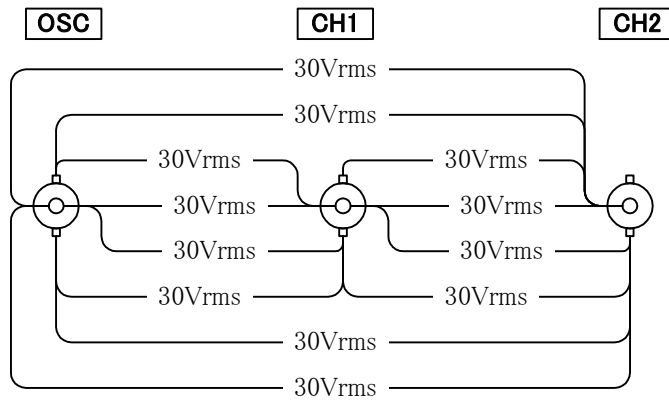

Fig. 9-4 Oscillation section input - analysis section input isolation voltage specifications (when a cable other than the accompanying cable is used)

9.3 Measurement process

- Mode

REPEAT	Repeatedly measures at a fixed frequency
SINGLE	Measures once at a fixed frequency
SWEEP	Measures while sweeping between the upper limit frequency and the lower limit frequency

- Auto ranging feature

A feature that switches the input range according to the input signal levels

- Delay feature

A feature that inserts a delay after changing the frequency before starting the measurement

Delay quantity is set either by the length of the time or by the number of cycles

During frequency sweeping, the following sequence is repeated: frequency measurement -> delay -> measurement.

Second setting

Setting range	0 to 9,999 seconds
Setting resolution	10ms

Cycle setting

Setting range	0 to 9,999 cycles
Setting resolution	1 cycle

- Integration feature

A data integration feature for measuring while eliminating noise effects

Measurement repetition is set either by the length of the time or by the number of cycles.

Cycle setting

Setting range	0 to 9,999 cycles
Setting resolution	1 cycle

Second setting

Setting range	0 to 9,999 seconds (one cycle of integration is always executed regardless of the setting)
Setting resolution	10 ms

- Automatic integration feature

A feature that repeats integration until reaching a certain reliability

Maximum integration time

Cycle setting

Setting range	2 to 9,999 cycles
Setting resolution	1 cycle

Second setting

Setting range	0 to 9,999 seconds (two cycles of integration are always executed regardless of the setting)
Setting resolution	10 ms

- Amplitude compression

A feature that controls the oscillator level in a way to keep the amplitude level of the measurement target system at a fixed value, to prevent saturations and breakages of the measurement target system.

The datum amplitude level is to be inputted to the reference channel.

Reference channel CH1 or CH2

Datum voltage range

 Setting range 1 mV to 250 Vrms

 Setting resolution 3 digits

Voltage limit range of the oscillator output voltage

 Setting range 1 mV to 10 Vpeak

 Setting resolution 3 digits

Error tolerance setting

 Setting range 0 to 100 %

 Setting resolution 1 %

Correction cycle

 Setting range 1 to 9,999

 Setting resolution 1

Correction ratio

 Setting range 0 to 100 %

 Setting resolution 1 %

- Frequency scale high density sweep (automatic low speed high density sweep)

A feature that correctly measures by automatically increasing the sweep density within the proximate frequency bands whenever measurement data changes greatly

Reference channel CH1 or CH2

Change width

a, b, R

 Setting range 0 to 1 GVrms

 Setting resolution 3 digits or 1 μ V, whichever is greater

dBR

 Setting range 0 to 1000 dB

 Setting resolution 3 digits or 0.01 dB, whichever is greater

Phase

 Setting range 0 to 180 degrees

 Setting resolution 3 digits or 0.01 degrees, whichever is greater

Operation mode

Manual Measures by a density higher than (4 times of) normal, and when a change above the designated change rate happens, the measurement is taken by an even higher density to cause the change rate between measurement points to be no more than the designated change rate

Auto Measures by normal density, and when a change above the designated change rate happens, the measurement is taken by higher density to cause the change rate between measurement points to be no more than the designated change rate

•Equalizing feature

A feature that measures the frequency characteristics of the measurement system including the sensors and cables, and later eliminates the errors posed by such measurement system during the real measurement, to gain characteristics relevant only to the measurement target

•Harmonic analysis feature

A feature that measures the harmonic components

2nd to 10th (highest frequency of the harmonics is 15 MHz)

9.4 Analysis process

- Analysis mode

Ratio ······CH1/CH2, CH2/CH1

Level ··· ··CH1, CH2

- Measurement error

When a calibration is executed shortly prior, and when the channels are either CH1/CH2 or CH2/CH1, and when the analysis input voltage is between 100 mV_{peak} and 10 V_{peak} (no more than 2 V_{peak} if 2.2 MHz is being exceeded):

	≤ 20 kHz	≤ 500 kHz	≤ 2.2 MHz	> 2.2 MHz
A, b, R	±0.5 %	±1 %	±10 %	±25 %
dBR	±0.05 dB	±0.1 dB	±1 dB	±2 dB
Phase	±0.3 °	±0.5 °	±2 °	±5 °

9.5 Calculations

- Four arithmetic operations

Four arithmetic operations between: data and data, data and numeric, numeric and numeric

- Derivation and integration

Data derivation, second order differential, integration, second order integration

- Open loop and closed loop conversion

Open loop -> closed loop conversion, closed loop -> open loop conversion

Feedback characteristics is specified by data or numeric

9.6 Auto sequence

- Key sequence record Records the key operations in the internal memory
- Key sequence execution Executes previously recorded key operations
- Key sequence deletion Deletes recorded key operations

9.7 Display

- Display device 6.5 inch color TFT LCD
- Graph Bode chart, Nyquist diagram, Nichols chart, Cole cole plot
(Cursor reading and autoscale available)
- Graph display style SINGLE/SPLIT
When SPLIT is chosen, the graph display area on the screen is split into two, and two graphs can be displayed simultaneously
- Measurement data display
 - Gain
 - Linear $\pm 9.999E+7$ to $\pm 1.000E-8$, as well as 0
 - Log $\pm 999.999dB$
 - Phase -180.00 deg. to 179.99 deg.
0.00 deg. to 359.99 deg.
-360.00 deg. to -0.01 deg.
 - Enlarged display When the measurement mode is SINGLE or REPEAT, measurement data are displayed enlarged in center of the LCD display device
- Auto scaling
 - A feature that automatically sets the graph display scale to optimum
 - Valid during measurements and also upon the initial data display
 - When the auto scale is OFF, the scale is fixed
- Marker display
 - Normal marker Displays a normal marker on the graph, and the data relevant to the position specified by the normal marker are displayed on the LCD numerically
 - Delta marker Displays a normal marker and a delta marker on the graph, while the difference between the normal marker and delta marker is displayed numerically
- Measurement data measurement condition display
 - Displays notable measurement conditions during the measurement of the data being displayed
- Graph types
 - Bode chart Amplitude - frequency, phase- frequency graph
 - Nyquist diagram a+jb display
 - Cole cole plot Displays the Nyquist diagram (a+jb) with the positive-negative of the imaginary axis (b) being reversed
 - Nichols chart The transfer function graph whose vertical axis is gain and horizontal axis is phase
- Condition setting/reference By menu
- Title display
 - Sets a title to measurement data and calculation data, and the title is displayed with the graph
- Date and time display
 - Displays the date and time which are either up to date, or are those of the time the data were sampled

9.8 Memory

- Memory operations
 - Storage of data into the memory
 - Deletion of on memory data
- Memory types

Mass memory	The variable length memory that stores the measurement data (Data is retained as long as the power is ON.) Worth at least 20,000 frequency points
Permanent memory	The variable length memory that stores the measurement data (battery backed up) Worth at least 2,000 frequency points

9.9 External memory

- Medium
 - USB flash drive
(Behavior of non-attached USB flash drive is not guaranteed)
- Connector
 - Front panel, USB-A connector
- File format
 - FAT (compatible with Windows 98SE or later running on PC/AT compatible machine)
- Memory contents
 - Setting condition
 - Measurement data
- File operation features
 - Directory (displays file list)
 - Rename (changes file name)
 - Delete (deletes files)
 - Save (saves data and setting conditions)
 - Load (reads out data and setting conditions)
- Screen image save feature

File format	MS Windows bitmap file (extension: .BMP, image size 640x480)
File size	Approximately 150 kB
File name	FRA ⁿⁿⁿ (ⁿⁿⁿ : 3 digit number, automatic increment, the initial value is specifiable)

9.10 Peripheral input/output functions

- GPIB

Interface feature SH1,AH1,T6,L4,SR1,RL1,PP0,DC1,DT0,C0

- USB

Standard USB1.1(Low Speed, Full Speed)

Connector Rear panel, USB-B connector

Device class TMC

- Thermal printer

A hardcopy of the LCD screen displaying the measurement data can be outputted from the built-in thermal printer

Paper width 112 mm

Suitable paper TP-451C (Seiko Instruments Inc.)

- DC power output

Power output used for our signal injector probe 5055 (sold separately)

Connector Rear panel, AUX connector

Output voltage Approximately ± 24 V

Output current Maximum 100 mA

9.11 Impedance display function

- Display items
 - R: Impedance or admittance
 - A: Resistance or conductance
 - B: Reactance or susceptance
- Additional graphs

Linear graphs (linear scale) and log graphs (log scale), 15 types

X axis	Y1 axis	Y2 axis	X axis	Y1 axis	Y2 axis
logF	logR	θ	F	logR	θ
logF	A	B	F	A	B
logF	logA	logB	F	logA	logB
logF	log(-A)	logB	F	log(-A)	logB
logF	logA	log(-B)	F	logA	log(-B)
logF	log(-A)	log(-B)	F	log(-A)	log(-B)
logF	logR	---	F	logR	---
θ	logR	---			

- Scale unit
 - Gain (abstract number)/impedance (Ω , S)
- Voltage and current input
 - CH1 fixed to voltage, CH2 fixed to current
- Current shunt input conversion coefficient
 - 0 to 1.0E+6 (resolution 5 digits or 0.01E-9), phase reverse feature
- Open/short correction feature

Open correction	Short correction	Correction formula
OFF	ON	$Z_x = Z - Z_s$
ON	OFF	$Z_x = Z_p \times Z \div (Z_p - Z)$
ON	ON	$Z_x = Z_p \times (Z - Z_s) \div (Z_p - (Z - Z_s))$

Z_x Correction calculation result

Z Measured value (CH1/CH2)

Z_s Short correction data (CH1/CH2)

Z_p Open correction data (CH1/CH2)

Calculation by the aforementioned formula applies regardless of the [ANALYSIS MODE] (analysis mode) setting.

- Maximum/minimum search feature

Search item	Y1-axis maximum, Y1-axis minimum, Y2-axis maximum, Y2-axis minimum
Search method	When the function key relevant to the search item is pressed when data marker is being displayed, the vertical axis parameters are automatically searched and the marker moves accordingly

9.12 Miscellaneous specifications

- Power input

Voltage	AC100 V/120 V/230 V \pm 10 %	should not exceed 250 V
Frequency	50 Hz/60 Hz \pm 2 Hz	
Power consumption	Maximum 100 VA	
Overvoltage category	II	

- Machine cooling

Forced air cooling, rear discharge type

- Installation posture

Parallel to the ground (within 10 degrees)

- Environmental conditions

Altitude 2000 m or less

Ambient temperature range and ambient humidity range

Performance guaranteed +5 to +35 °C, 5 to 85 % RH
(Furthermore, AH 1 to 25 g/m³, no condensation)

Storage conditions -5 to +50 °C, 5 to 95 % RH
(Furthermore, AH 1 to 29 g/m³, no condensation)

Pollution degree 2

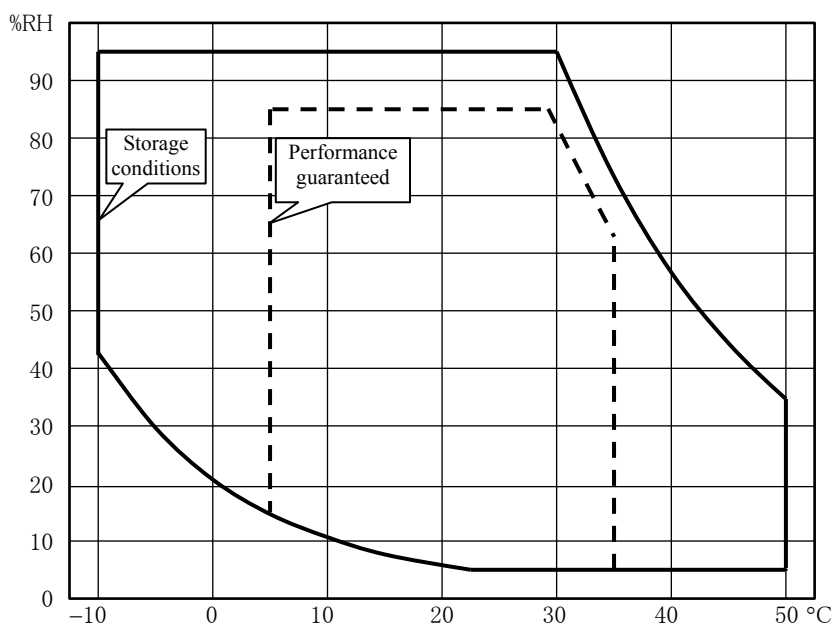

● Insulation resistance	No less than 20 M Ω (at AC 500 V, between power inputs altogether and the enclosure)
● Withstand voltage	AC 1500 V (between power inputs altogether and the enclosure)
● External dimensions	434 (W) x 177 (H) x 453 (D) mm (without protrusions)
● Weight	Approximately 12 kg (weight of the main unit excluding other matters such as accessories and options)
● Safety	EN 61010-1:2010 EN 61010-2-030:2010
● EMC	EN 61326:2013 (Group 1, Class A) EN 61000-3-2:2006+A1:2009+A2:2009 EN 61000-3-3:2013

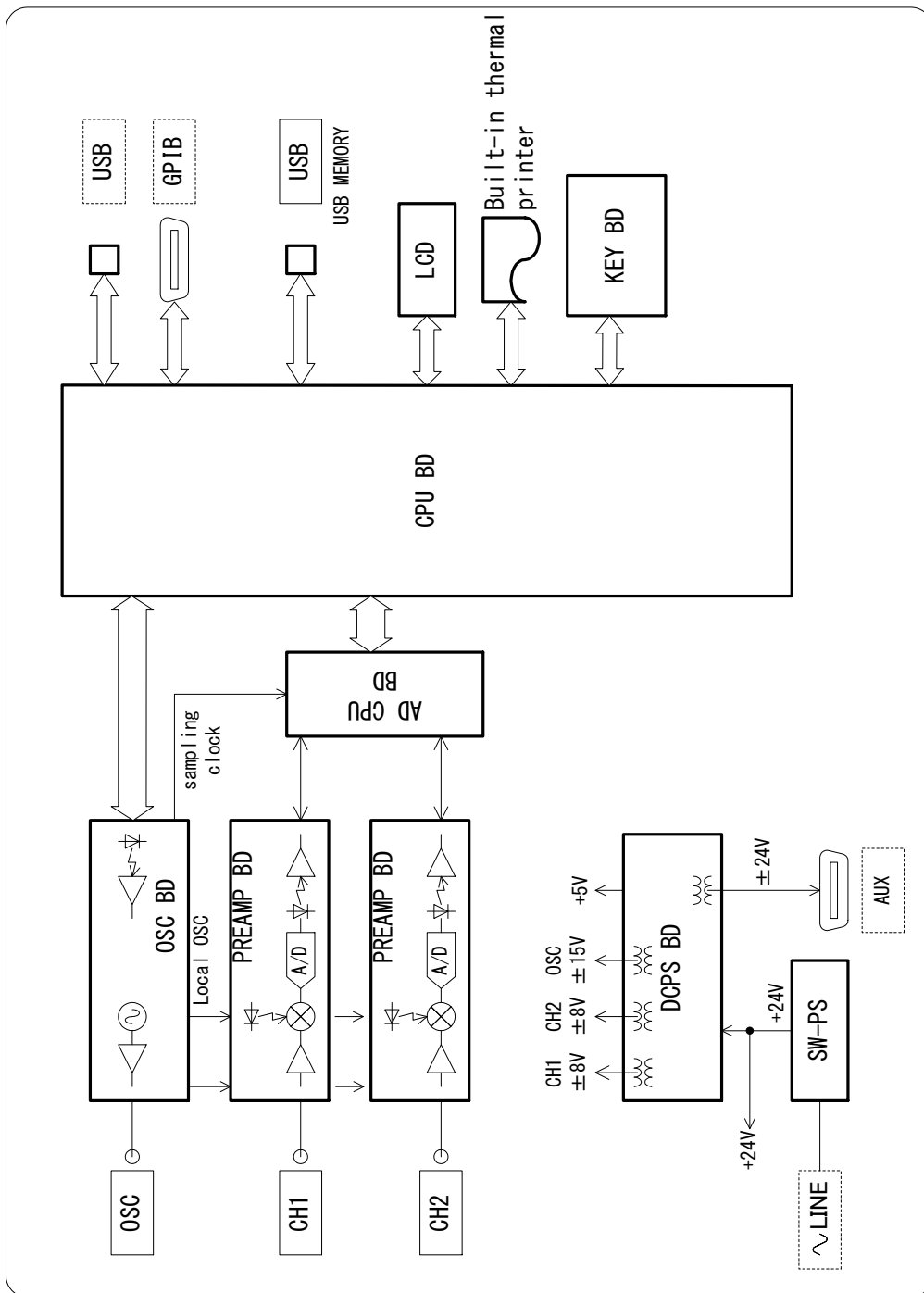

Fig. 9-5 Block diagram

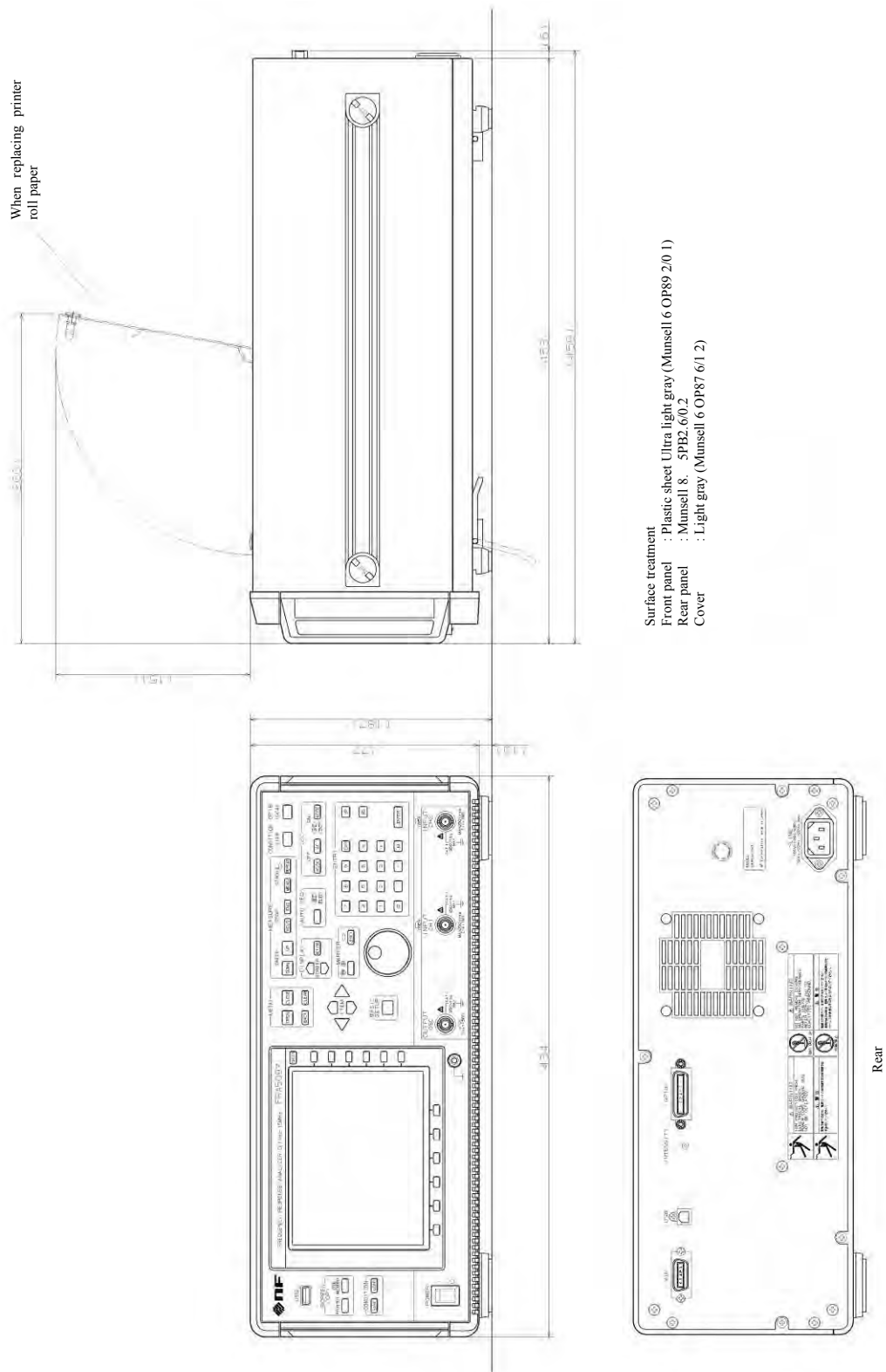

Fig. 9-6 External dimensions diagram

Warranty

NF Corporation certifies that this product was thoroughly tested and inspected and found to meet its published specifications when it was shipped from our factory.

All **NF** products are warranted against defects in materials and workmanship for a period of one year from the date of shipment. During the warranty period, **NF** will repair the defective product without any charge for the parts and labor. For repair service under warranty, the product must be returned to either **NF** or an agent designated by **NF**. Purchaser shall prepay shipping charge, duties and taxes for the product to either **NF** or the agent from another country, and shipping charge for the return of the product to purchaser shall be paid by **NF** side.

This warranty shall not apply to any defect, failure or damage caused by a) improper use; b) improper or inadequate maintenance and care; or c) modification by purchaser or personnel other than **NF** representatives.

Request for Repair

When a failure occurred and the product was found to be defective or you have any uncertainty, please get in touch with NF Corporation or one of our representatives.

In such a case, let us know the model name (or product name), serial number (SERIAL No. given on the nameplate), and symptom and operating conditions as detail as possible.

Though we will make efforts to reduce the repair period, when five or more years have passed since you purchased the product, it may take time due to, for instance, the out of stock of repair parts.

Also, if the production of repair parts is discontinued, the product is extremely damaged, or the product is modified, we may decline the repair.

If there are any misplaced or missing pages, we will replace the manual. Contact the sales representative.

NOTES:

- Reproduction of the contents of this manual is forbidden by applicable laws.
- The contents of this manual may be revised without notice.
- Information provided in this manual is intended to be accurate and reliable. However, we assume no responsibility for any damage regarding the contents of this manual.
- We assume no responsibility for influences resulting from the operations in this manual.

Copyright 2006 - 2017, **NF CORPORATION**

FRA5097 Frequency Response Analyzer Instruction Manual

NF CORPORATION

6-3-20 Tsunashima Higashi, Kohoku-ku, Yokohama
223-8508, JAPAN

Phone: 81-45-545-8128 Fax: 81-45-545-8187

