



For your reference:

Please note that this product is no longer available and is provided as a reference technical document.

AC POWER SUPPLY

EPO2000S / EPO2000X

INSTRUCTION MANUAL

2-STATION ● EPO

Notice to the customers

Thank you for purchasing the high-efficiency system power supply P-STATION/EPO series.

There are two pages to be corrected in the instruction manual attached to the product. Instruction Manual for High-efficiency System Power Supply EPO 2000S/EPO 2000X (our document No. D:509763).

Please take the trouble to replace the corresponding pages with the following pages in this material:

Page 5-3

Page 12-2

Using the measurement functions

- 1 Every press on  changes the indication of measurement in turn.

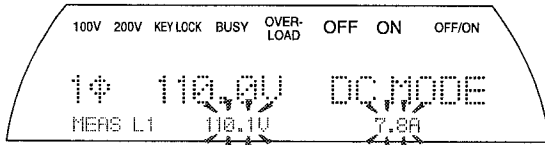

Measurements are shown in the bottom line of the display.

* Measurements of "Voltage", "Current" and "Power" are displayed when in DC output mode.

[Example] Mean value of voltage and current

MEAS L1	110.1V	7.8A
Effective power		
MEAS L1		0.86kW



Attention!

- The measurement range is switched automatically.
- The measurement range cannot be fixed.



Attention!

- Mean values are displayed for voltage and current in DC output mode, and AC components are not measured.



Memo

- If the current contains an AC component, a peak value will be detected and this switches the DC measurement range to a higher range.

Attention!

- Load connecting method in DC mode

For fault prevention and safety, if a capacitor, motor or an inductor is used as a load, connect a protective diode (with the maximum inverse voltage of 600 V at least) between the load and the P-STATION/EPO output. Select a large one with the forward current of which the rating is 1.5 times or more of the applied system maximum current.

- If a capacitor (of 150 μ F at least) or a motor is used as a load, connect a blocking diode which prevents the backflow of the current.
- If an inductor is used as a load, connect a freewheel diode so that the counter electromotive force generated when the output is off is absorbed.

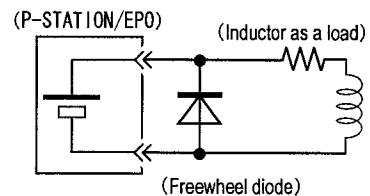
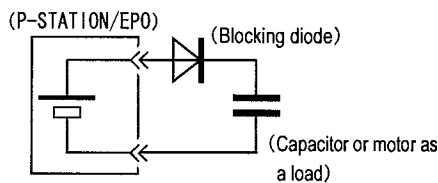

Memo

Most of the switching power units used by connecting with an AC power supply can be operate in DC mode and the measurement of efficiency is sometimes performed with a DC power supply. If this is the case, it is not necessary to connect a protective diode because the backflow from the capacitor, etc. inside the circuit is blocked by the action of the commutating diode (normally of a bridge configuration) located in the input section of the switching power unit.

Rush current versus supply time

* $V_o = 100.0V$ (100V range) or $200.0V$ (200V range), $f = 50Hz$, at Power-ON phase 0°

This indicates the time (rush supply time) spent until the output is restrained by the protective circuit operation when rush current is applied to a resistance load.

Rated current = 20A (100V range), 10A (200V range)

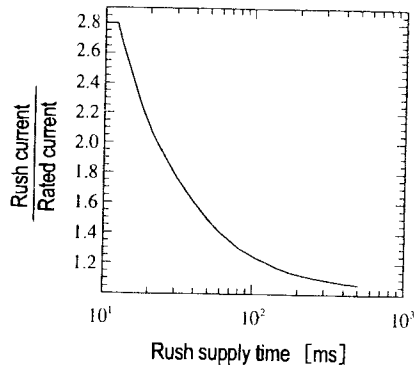
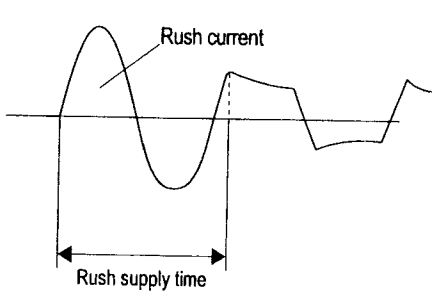

Maximum output current versus frequency

* Maximum current decreases at frequency lower than 40Hz.

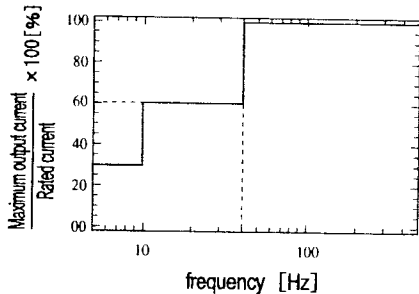

Maximum output current versus output voltage (AC mode)

* Maximum current decreases at voltage higher than 100.0V (for 100V range) or 200.0V (for 200V range).

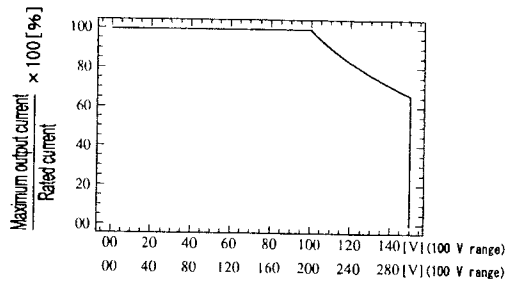

Remarks: [A] means [Arms], [V] means [Vrms] unless any other special description is given. Signal waveform is a sinusoidal wave.

- *1 Setting resolution is 0.1V for phase voltage and 0.2V for line-to-line voltage.
- *2 With sinusoidal wave. Output current decreases if output frequency is 40 Hz or lower.
- *3 With phase current.
- *4 A short period until mean value protection operates. However, repeated application is allowed to capacitor input type rectifying load (at 48 to 62 Hz).
- *5 DC mode cannot be used in single-phase three-wire or three-phase system.
- *6 EPO 2000S and EPO 2000X units are operable at 100V although the output is limited to 800 VA.
- *7 At input voltage of 200V.
- *8 Measurement accuracy is for full scale (FS) of each measurement range.
- *9 Effective measurement range of voltage and current is 40 to 500 Hz.
Effective measurement range of effective power is 45 to 65 Hz.
- *10 Stipulated with chassis - power supply input in package versus output, chassis - output in package versus power supply input.
- *11 Accessories and optional items are excluded.

D:509763

**EPO 2000S/EPO 2000X
Instruction Manual
High-efficiency System
Power Supply**

AC POWER SUPPLY

2-STATION

EPO

If the document is incorrectly collated, contact the dealer for replacement.

Notes:

- Copy and reprint of any or all of the contents of this document without permission are prohibited by law.
- Contents of this document are subject to alteration without notification.
- We shall not be responsible for damage resulted from the contents of this document although careful elaboration has been exerted in preparation of the document.
- We shall not be responsible for effects of consequence of operation performed according to the document.

Copyright *NF Corporation 2000*

Caution prior to exportation

- It is prohibited to export or bring out this product from Japan to any foreign country without permission. The predetermined formalities must be done following the applicable laws and rules.

Instructions for safe use of the product

For safe use of EPO 2000S/2000X, observe the instructions in the following section. The company shall not be responsible for, nor take compensation of, the damage resulting from violation of these instructions.

Observe the contents of this document

This instruction manual contains instructions for safe operation and use of EPO 2000S/2000X.

Be sure to read first this manual before starting operation. After thorough reading, store the document carefully so that it will be accessible for reference when uncertainty is encountered in the future.

Observe the descriptions of WARNING and CAUTION

Be sure to observe descriptions of WARNING and CUATION contained in this manual and those affixed on EPO 2000S/2000X units because they are intended to prevent hazard that may result in serious accidents.



This note on the product or in the manual indicates information to avoid hazard which the life or body of the user is subject to during handling of the equipment.



This note on the product or in the manual indicates information to avoid damage to the EPO 2000S/2000X unit.



This symbol on the product indicates controls or functions the use of which requires reference to this instruction manual in advance.

Damage during transport and storage

- If the EPO 2000S/2000X unit is found damaged by vibration or impact during transport or storage, safety protection functions may have been lost. Keep the unit as it is and immediately contact the company or the dealer.



Do not remove the cover or modify the unit

- Never remove the cover. Do not attempt repair, inspection or adjustment of parts inside.
- Never attempt to modify parts inside. This may result in system failure or accidents.

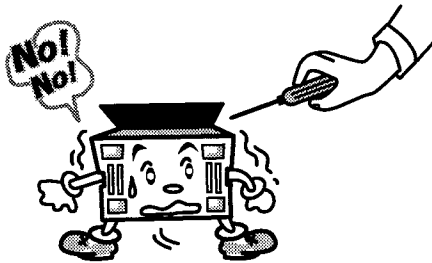

Install the unit in flat and rigid place

- For unit installation, select a flat and strong place free from tilting or vibration that can support easily the weight of the EPO 2000S/2000X unit (approximately 25 kg per unit).

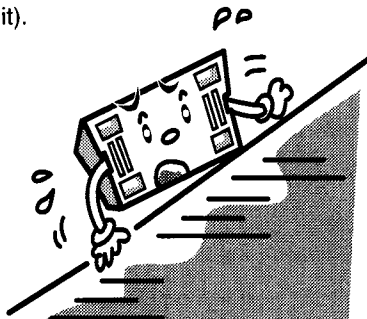

Never select any of the following places for installation

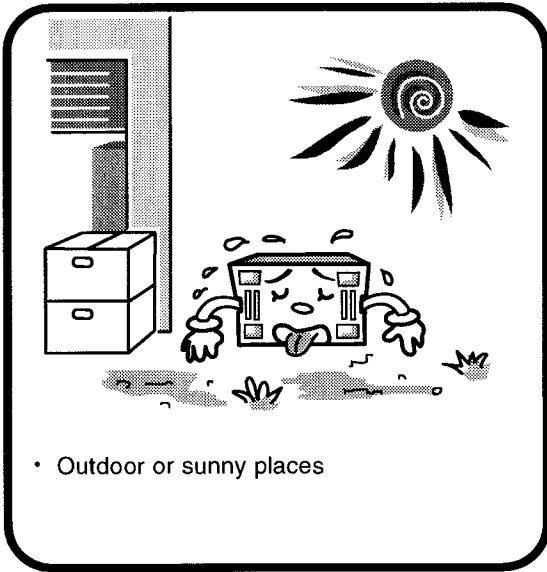

- Outdoor or sunny places



- Small places with poor ventilation

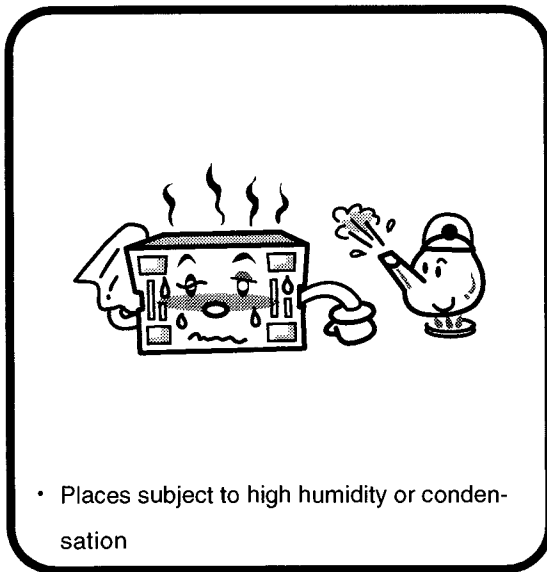

- Places subject to high humidity or condensation



- Dusty and dirty places



- Places exposed to corrosive, explosive or flammable gases

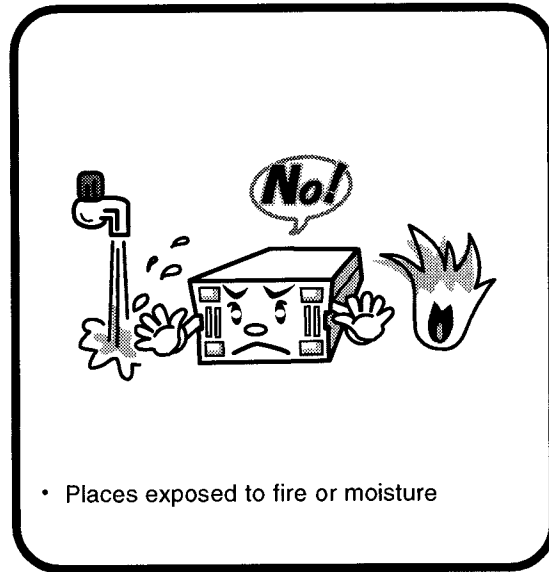

- Places exposed to fire or moisture



WARNING

Power supply cord

- Use the supplied power supply cord for power input. If any other cord is used for unavoidable reasons, select one that has electrical and mechanical properties equivalent to that.

Avoid electric shock

- Be sure to shut off the switch on the power switchboard before connecting the power supply cord.
- Turn off the power switch of the EPO 2000S/EPO 2000X unit before connecting output cables.
- Connect the protective grounding terminal of the EPO 2000S/EPO 2000X unit positively to the electric ground which ground resistance is less than 100 Ω .
- Do not touch by hand the chassis that is not connected to a ground because a line filter is incorporated in the power input section.



- Securely tighten screws and positively plug connectors so that input and output cords and other cables will not be unplugged accidentally. Also pay attention to cord and cable placement to protect them from treading and jerking.

Be alert to burning

- Pay attention to prevent personnel from direct touch on the exhaust port of the EPO 2000S/EPO 2000X unit.



Be aware of electric shock and failure

- If condensation comes into notice, wait until the condensation disappears before connecting the power supply.
- Do not connect other wires other than the grounding wire to the protective grounding terminal.
- Never put foreign matters or liquids in the EPO 2000S/EPO 2000X unit.

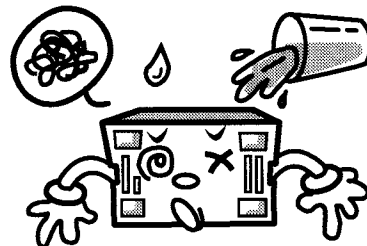

- Wiring in the input and output sections should be carried out elaborately so that the conductive part of the connection cord will not be exposed.



CAUTION

Instructions on use

- Use the product within the specified range of ambient temperature and humidity.

For operation : 0 to 40°C , 10 to 90%RH

For storage : -10 to 50°C , 10 to 90%RH

For guarantee of performance:

5 to 35°C , 50 +10%RH

(No condensation)

- Select a power supply to the EPO 2000S/ EPO 2000X unit in the rated range (single-phase AC power supply of 48 to 62 Hz, 170 to 250 V).

- In order to maintain proper forced air cooling, place the unit so that front and rear sections will be 50 cm or more away from walls for adequate ventilation.

- An EPO 2000S/EPO 2000X unit consumes electric power of about 2800 VA at the maximum. This means, the input current will be approximately 16.5 A if the power supply voltage is 170 V. Therefore, select a power supply with sufficient capacity.

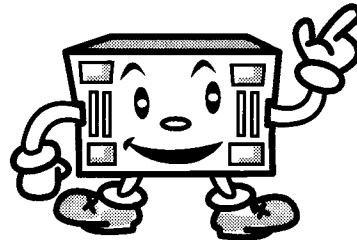



Safety and instructive expressions used in this manual



WARNING

This note on the product or in the manual indicates information to avoid hazard which the life or body of the user is subject to during handling of equipment.



CAUTION

This note on the product or in the manual indicates information to avoid damage to the EPO 2000S/2000X unit.



Attention!

An instruction on operations in which users are likely to do wrong things.



Memo

Introduction of a function useful in some future occasions.

Contents

	PAGE
Instructions for safe use of the product	0-1
Safety and instructive expressions used in this manual	0-6
1. Introduction	
Outline of EPO 2000S/EPO 2000X	1-1
Check accessories in package first!	1-3
2. Name of parts	
Front panel I	2-1
Rear panel	2-1
Operation panel I	2-2
3. Installation and Connection	
Selection of power supply environment	3-1
Grounding	3-2
Connection to input and output terminals	3-3
Connection to power input terminal	3-3
Connection to output terminal	3-3
Cable connection to screwed terminal block	3-4
Connection of single-phase 2 kVA system	3-6
Connection of single-phase 4 kVA system (use two EPO 2000X units)	3-7
Connection of single-phase 6 kVA system (use three EPO 2000X units)	3-8
Connection of three-phase 6 kVA system (use three EPO 2000X units)	3-9
Connection of single-phase three-wire 4 kVA system (use two EPO 2000X units)	3-10
Prior to starting operation	3-11
4. Fundamental Use - for beginners -	
Turning ON/OFF power supply	4-1
Setting the output voltage range	4-2
Setting the output voltage	4-3
Setting the output frequency	4-4
Turning ON/OFF the output	4-5
Indication of overload	4-6

	PAGE
Using measuring functions	4-7
Setting limits to output	4-8
Setting an upper limit to output voltage	4-9
Setting an upper limit to output frequency	4-9
Setting a lower limit to output frequency	4-10
5. Versatile Use - for advanced users -	
Using the unit as a DC power supply	5-1
Selecting DC output mode	5-1
Setting an output voltage range	5-2
Setting an output voltage	5-2
Using the measurement functions	5-3
Settings for output compensation mode	5-4
Selecting low sensitivity (or high stability)	5-4
Selecting high sensitivity (or precision)	5-5
Using storage function	5-6
Storing settings	5-6
Recalling settings	5-7
Recalling at one action with preset key	5-7
Retrieving on-shipping settings	5-8
Measuring rush current	5-10
Setting the power-on phase on output turn-on	5-10
Using the peak hold function	5-11
6. Use of Enhanced EPO 2000X System	
- increase the system output capacity or use units in a three-phase or single-phase three-wire configuration -	
What functions are available by system enhancement?	6-1
Connection of system cable	6-1
Phase mode	6-1
Restrains on memory	6-1
Using the system as a single-phase 4 or 6 kVA power supply	6-2
Turning ON/OFF the power	6-2
Changing to single-phase mode	6-3
Using the system as a three-phase 6 kVA power supply	6-5
Turning ON/OFF the power	6-5
Changing to three-phase mode	6-6
Exemplary voltage setting: supplying three-phase 200 V output	6-8
Using a measuring function in three-phase configuration	6-9
Different functions in three-phase mode	6-10
Phase indication and phases	6-10

	PAGE
Using the system as a single-phase three-wire 4 kVA power supply ...	6-11
Turning ON/OFF the power	6-11
Changing to single-phase three-wire mode	6-12
Exemplary voltage setting: supplying single-phase three-wire 200 V output	6-14
Using a measuring function in single-phase three-wire configuration	6-15
Different functions in single-phase three-wire mode	6-16
Phase indication and phases	6-16
Reducing the system into a singular unit operation	6-17
7. Useful Functions - versatile functions are ready for use -	
Using numeric keypad for setting	7-1
Connecting the numeric keypad	7-1
Selecting operation mode of numeric keypad	7-2
Operation in numeric entry (10KEY) mode	7-3
Setting the output voltage by numeric entry	7-3
Setting memory recall address by numeric entry	7-4
Operation in memory recall (RECALL) mode	7-5
Recalling the contents in memory by a single button touch on the numeric keypad ...	7-5
Line synchronization	7-6
Enabling line synchronization	7-6
Disabling line synchronization	7-6
Setting the reset frequency at the line synchronization OFF moment	7-7
Switching ON/OFF beep warning	7-8
Enabling/disabling beep warning	7-8
Key lock	7-9
Enabling key lock	7-9
Disabling key lock	7-10
Operation with 100 V input	7-11
8. GPIB Interface	
Outline of GPIB	8-1
Functions that cannot be operated via GPIB	8-1
Functions that can be controlled via the GPIB but cannot be operated from the panel ...	8-1
Applicable specification	8-1
Connection of GPIB cable	8-2
Instructions on use of GPIB	8-2
Setting for GPIB use	8-3
Selecting the interface	8-3
Setting the GPIB address	8-3
Setting terminator	8-4
Remote status and release from remote condition	8-5

	PAGE
Remote state	8-5
Local state	8-5
Setting the system to "Local lockout"	8-5
Service request and status structure	8-6
Outline of status report	8-6
Status byte	8-6
Sending a service request	8-6
Capture of an event	8-6
Grasp of queue situation	8-6
Status byte register and sending a service request	8-7
Detailed structure of status	8-9
Standard event status register and related registers	8-10
Operation status register and related registers	8-12
Extended event register and related registers	8-13
Warning event register and related registers	8-14
Operation event register and related register	8-15
Fail event register and related registers	8-16
Overload event register and related registers	8-17
Extended status register and related registers	8-18
Program messages	8-19
Program message basic form	8-19
Setting messages	8-20
Data form in setting messages	8-20
Querying message	8-20
Form of response data to a querying message	8-21
Situation in which no message is accepted (Busy)	8-22
Busy related messages	8-22
To recognize BG state from controller	8-22
List of program messages	8-23
Setting of output voltage and output range	8-23
Setting of output frequency	8-24
Switching ON/OFF the output	8-24
Measuring function	8-25
Setting limit values	8-26
Setting a Power-ON phase	8-27
Precision mode and high stability mode setting	8-27
Line synchronization	8-27
AC/DC selection	8-28
Phase mode	8-28
Beep	8-28
Remote sensing AGC	8-29
Monitor output	8-29
Memory	8-30

	PAGE
Hardware structure	8-31
Interface and Status related	8-32
Response to interface message	8-33
Sample GPIB program	8-34
Outline of sample program	8-34
Case where Visual Basic and Kithley's GPIB interface board are used	8-35
Case where Visual Basic and National Instruments' GPIB interface board are used ...	8-39
9. RS-232 Interface	
Outline of RS-232	9-1
Settings for using RS-232	9-2
Selecting the interface	9-2
Setting the transfer rate	9-3
Setting a delimiter for sending	9-3
Setting the parity	9-3
Setting the stop bit	9-4
Setting the character length	9-4
Connection of RS-232 cable	9-6
Handshake	9-7
Sample RS-232 program	9-8
10. Maintenance	
Backup battery	10-1
Calibration	10-1
11. Solution of Trouble	
Fault diagnosis	11-1
Settings retained by backup battery	11-2
Protective functions	11-3
Troubleshooting	11-4
Phenomenon on power turning on	11-4
Buttons are inoperable	11-4
Phenomenon relating to voltage range setting	11-5
Phenomenon relating to frequency setting	11-5
Phenomenon relating to line synchronization	11-5
Phenomenon relating to overload	11-6
Phenomenon relating to measurement function	11-6
Phenomenon relating to storage function and preset	11-6
Phenomenon on power turning off	11-7
If a motor is connected as load	11-7

	PAGE
If a transformer is connected as load	11-8
Frequently asked questions and answers to them	11-9

12. Rating

13. Terminology

Warranty

● CONTENTS ●

Introduction

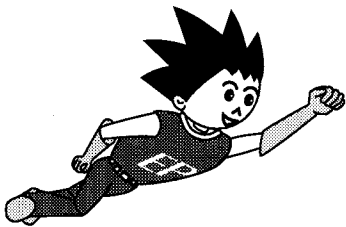

Outline of EPO 2000S/EPO 2000X



Hi, there. My name is "High-efficiency System Power Supply, P-STATION/EPO". Oh, this may be too long for you. Then call me "Epo" in short. Before going to sections of detailed description, I will introduce some of my fortes.

You do simple setting and I will supply high-accuracy voltage.

- * Just turn the dial to the desired spot, or use an external numeric keypad (optional) to enter your desired value. This easy setting enables me to provide output voltage of 0 to 300 V in AC or 0 to 424 V in DC with the frequency of 5 to 500 Hz as you desire.

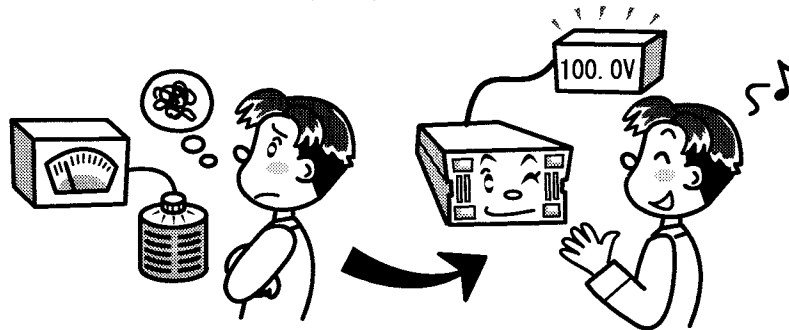

I supply clean and stable voltage.

- * Even if the load current fluctuates, I continue to supply a voltage that is mostly constant and free of distortion. Stability of output voltage versus fluctuation to load is 0.1% (typically) or less.

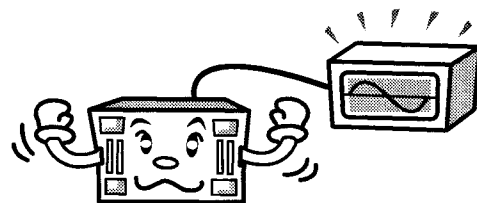

I strive to supply constant output even if the input power fluctuates severely.

- * I provide stable output even in an adverse power environment since the range of my tolerance to power supply voltage is so wide (170 V to 250 V) and I have a high tolerance ability against instantaneous power interruptions; namely, the maximum tolerance time is as long as 20ms typically.

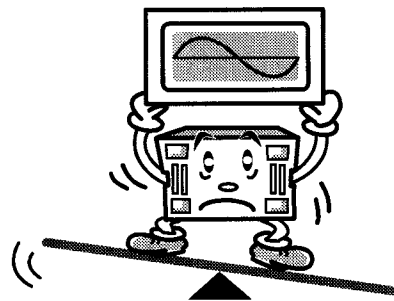

<Higher efficiency and less heating>

The efficiency is improved to the level of about 76% at the maximum. Internal loss at the rated output (2 kVA) is as low as 1/3 of the traditional products (NF's P-STATION/series [Q]), namely, about 600W.

<I am small and light, needing only a limited space.>

I weigh 25kg or so, approximately a half of conventional products. Thanks to the weight reduction, you can easily move me or transport me.

<I am ready to supply rush current.>

I can provide a flow of 2.8 times the rated current (in RMS value) for a short time, and even four times at peak. Also can provide motor starting current without problem.

<I can show you the behavior of rush current.>

Sine setting of the AC voltage phase is available in the range of 0° to 270° in 90° increment, you can observe the behavior of the rush current flowing to the load while changing the conditions. In addition, my "peak hold" function allows you to observe the highest peak value of the current that flowed at that moment.

<I can provide not only AC output, but also DC.>

Similarly to AC output, setting of voltage value (0 to 424 V) is simple. You can use DC output when testing a DC/DC converter or the like.

<You can achieve capacity increase and three-phase output easily> (applicable to EPO 2000X only).

Just connect EPO 2000X units with an optional system cable, and you can increase the system capacity, and achieve three-phase, single-phase three-wire power supply with ease. Then remove the system cable, and you can retrieve an independent single-phase 2 kVA power supply system. This function releases you from troublesome feeling when you want to change the system frequently.

<I am provided with an interface for computer control.>

Two types are provided for standard: one is GPIB, a standard interface for instrumentation and the other is RS-232, commonly incorporated in personal computers.



Check accessories in package first!

When a package of product reaches you, check for all items first. The package should contain the following accessories:



One unit of high-efficiency system power supply, EPO 2000S (or EPO 2000X), main body

Three power cords (3m long 3.5mm² vinyl insulated cables)

One instruction manual for "EPO 2000S/EPO 2000X" (this document)

One flat-blade screwdriver for input/output wiring

If any of the above is missing, contact the company or the dealer.

2

Name of parts

■ In this chapter, I will explain the name of parts and controls of your EPO 2000S/EPO 2000X unit.



Front panel

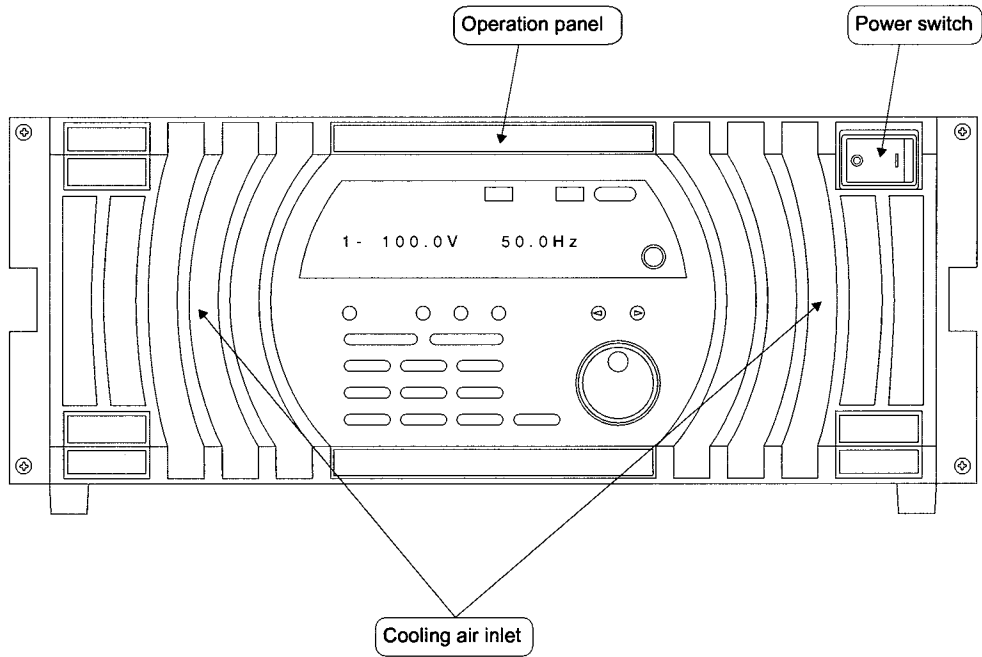

Rear panel

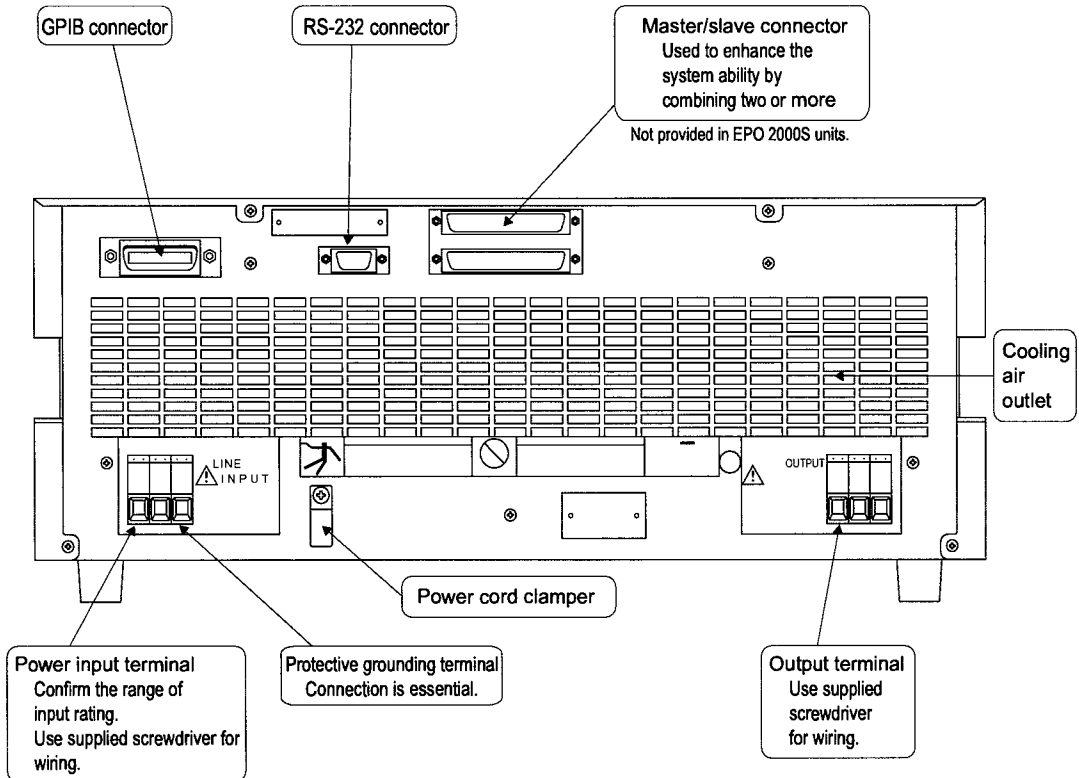

● 2. Name of parts

Operation panel

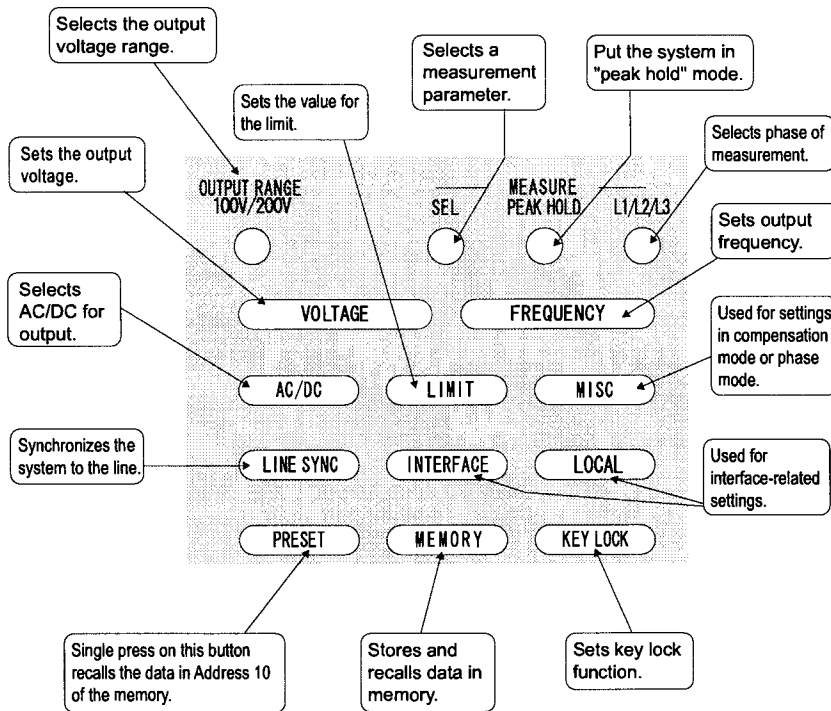
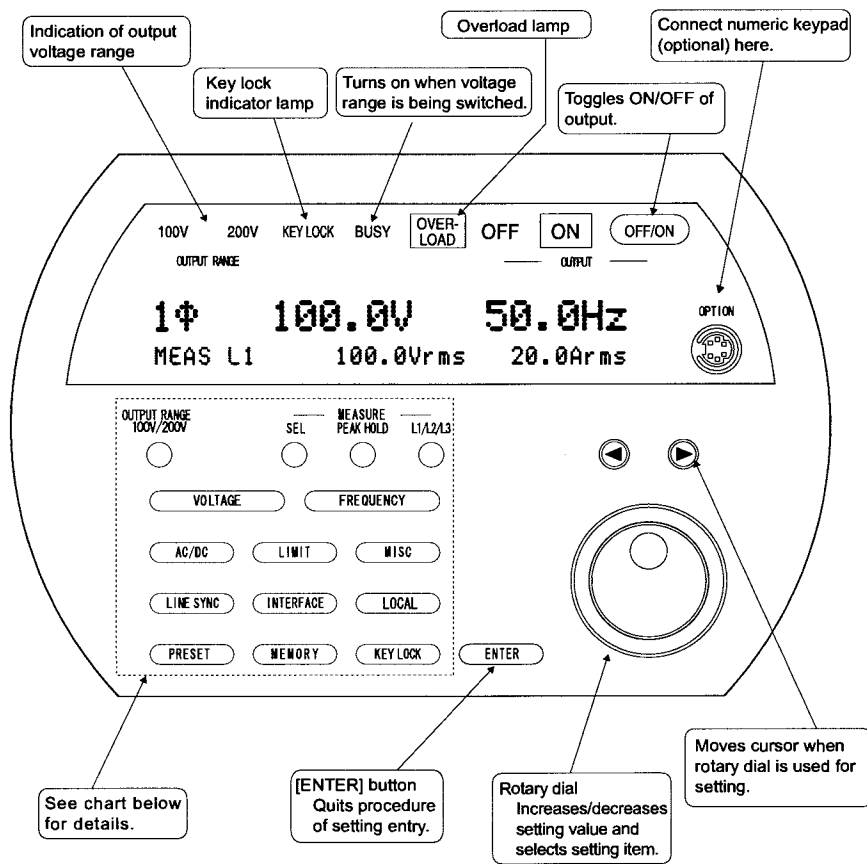

2. Name of parts

3

Installation and Connection

■ This chapter is provided for preparation for starting use of the unit. Please read instructions for installation, and then also read instructions for power connection and different procedures so that the system will be ready for use.

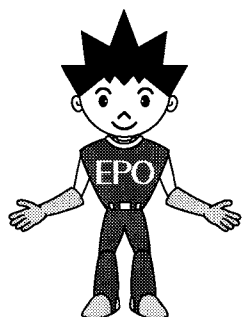



Selection of power supply environment

To ensure safety, use the product in a power supply environment that meets the following conditions:

- Use a power supply that meets the rated range (single-phase AC of 48 to 62 Hz, 170 to 250 V).
- An EPO 2000S/EPO 2000X unit consumes power of about 2.8 kVA. This means, the input current will be approximately 16.5 A at the highest if the power supply voltage is 170 V. Confirm that the planned power supply has a sufficient capacity for the requirement.
- For connection of power supply, use the supplied power cable or another cable that has the same size or thicker diameter.
- Pay ample attention to screw tightening and placement of cables so that the power cable will not be unplugged or loosened accidentally.

● Grounding

Be sure to connect the protective grounding terminal  positively to the electric ground which ground resistance is less than 100 Ω to avoid risk of electric shock.



WARNING

Electric shock will be caused if you touch the chassis that is not connected to the ground because a line filter is used in the power input section.

Be sure to connect the protective grounding terminal before plug in the power cord.



Connection to input and output terminals

Be sure to shut off the power supply on the power switchboard before connection in order to avoid risk of electric shock.

Connection to power input terminal

Use the supplied power cable to place 200 V power supply wiring from the power switchboard to the power input terminal on the rear panel. Indications of L, N and  are marked on the power input terminals. If the power switchboard used is such that one of two conductors is grounded, then connect the grounded pole to the N terminal and the ungrounded pole to the L terminal, respectively. If the power switchboard has a single-phase three-wire structure, then use the 200 V phase between the 1st and 2nd phases for connection instead of using the neutral conductor (or grounding pole). Be sure to connect the protective grounding terminal as well.



WARNING

Be sure to shut off the power supply on the power switchboard before connection in order to avoid risk of electric shock. It is also essential to connect the protective grounding terminal positively.

Connection to output terminal

Output is insulated from the power input.

Both of Hi and Lo of output are insulated from the chassis. Also the Lo terminal can be connected to the chassis for use.



WARNING

Turn off the power to the EPO 2000S/EPO 2000X unit before safe connection of output.



Memo

The internal circuitry of the EPO 2000S/EPO 2000X unit controls the output terminal voltage to be constant at the set voltage. As a result, the load regulation at the load end is affected by the impedance of the wire to the load.

Use a wire with a proper length (not too long unnecessarily) to connect the output terminal to the load and ensure that the terminal connection is made positively without potential loosening. Use an output cable with nominal cross section of at least 3.5mm² or so.

Cable connection to screwed terminal block

This type of terminal accepts a stranded wire of 3.5mm² to 8mm² or a single wire.

Do not carry out any terminal treatment. However, take care so that the tip of the stranded wire will not go through the terminal. The proper tightening torque is 1.8 [N · m] (ca 18 [kgf · cm]).

Procedure of connection

- (1) Strip off 11mm of insulation.
- (2) Use the supplied screwdriver to loosen the screw on the terminal and widen the cable port to the maximum.
- (3) Insert the conductor of the cable.
- (4) Tighten the screw with the driver.

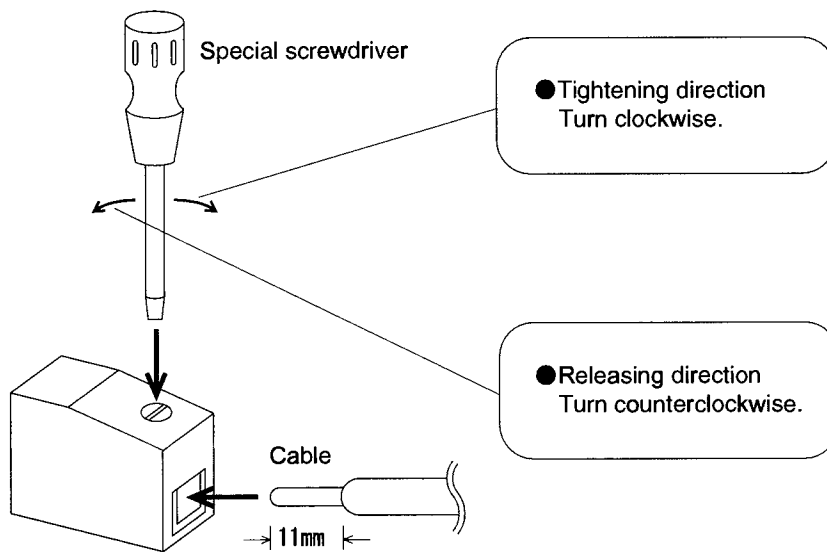

⚠ WARNING

- Be sure to turn off the power before starting connection in order to avoid the risk of electric shock. Note that the metal part of the screw is not isolated from the terminal

⚠ WARNING

- When using a stranded wire, directly insert the copper wire as it is. Carrying out terminal treatment by soldering in particular may cause the contact section to heat abnormally, likely to burn the cable or terminal.

⚠ WARNING

- Insert only one cable to a terminal to avoid a risk. If two or more wires are inserted, they are likely to become loose or come off by a pulling force.

⚠ CAUTION

- Use the supplied screwdriver in wiring operation to ensure positive fastening without damaging the slot of the screw.



Memo

Select a proper cable referring to the table below that shows the relationship between cables and allowable current.

Allowable current for two-core vinyl cabtyre cable

* For VCT cables as per JIS C 3312

(At ambient temperature of 30°C or below)

Nominal cross section [mm ²]	Allowable current [A]
2	22
3.5	32
5.5	42
8	51
14	71
22	95
38	130

(At ambient temperature higher than 30°C)

* Multiply the allowable current value shown in the left table with the reduction factor in the table below

Ambient temperature [°C]	Reduction factor to allowable current
30	1.00
35	0.91
40	0.82
45	0.71
50	0.58

* From JEAC 8001-1986

Relationship between cable length and voltage drop (JIS C 3307 IV cable)

* Use of too long cable causes a voltage drop due to the excessive cable resistance.

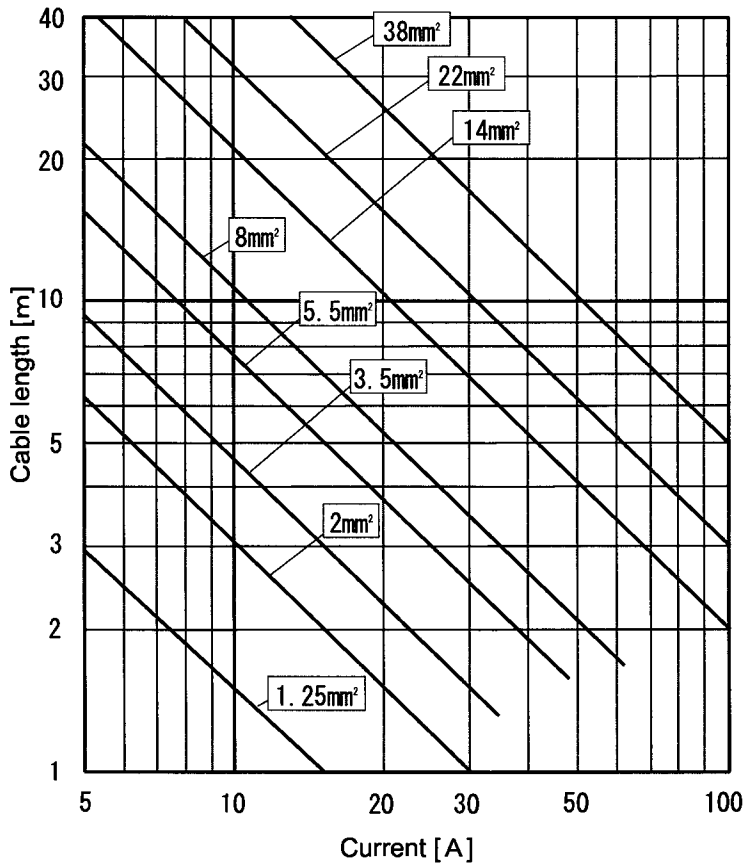

* The diagonal lines indicate the cable length at which voltage drop is 0.5 V due to wiring resistance.

* Values in the rectangle indicate the cross section of the conductor.

Connection of single-phase 2 kVA system

In case of one EPO 2000S/EPO 2000X unit to use, connection should be made as shown in the diagram below:

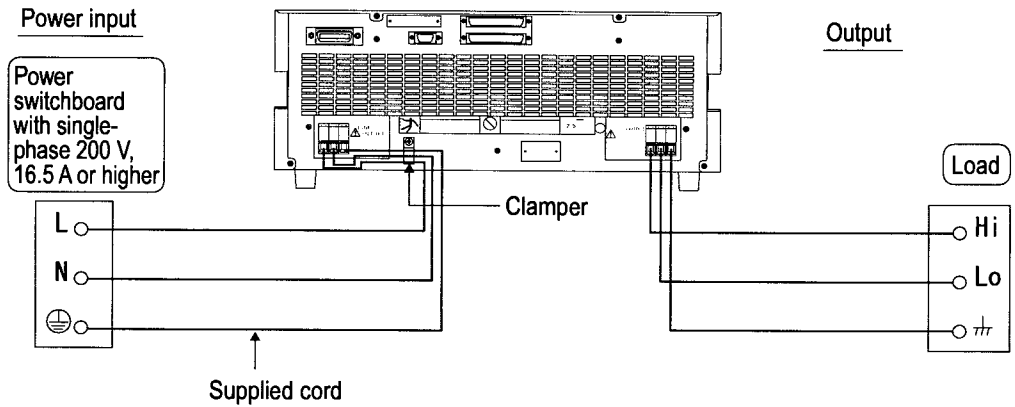

⚠ WARNING

Use clampers in the power input section in particular to fix the cord so that the cord will not be disconnected accidentally, avoiding electric shock and failure.

Connection of single-phase 4 kVA system (use two EPO 2000X units)

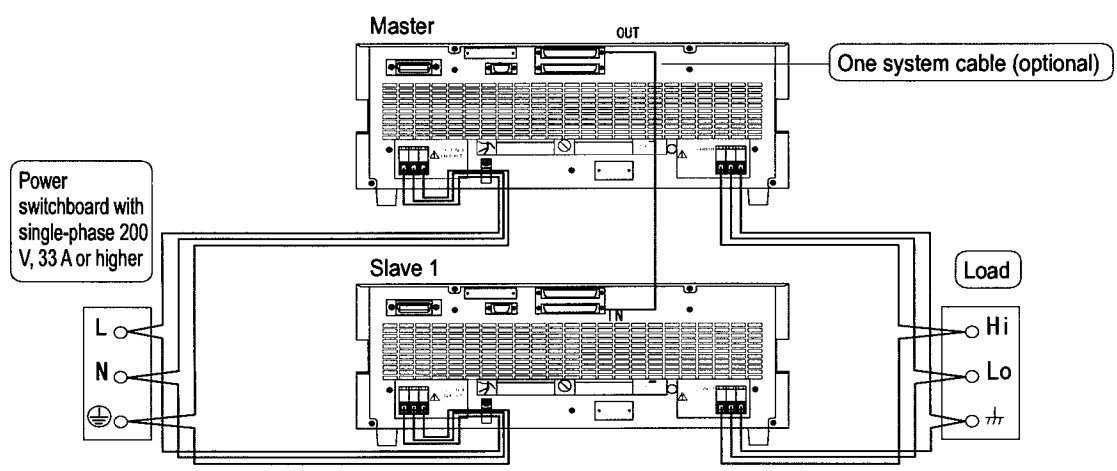

! WARNING

Use claspers in the power input section in particular to fix the cord so that the cord will not be disconnected accidentally, avoiding electric shock and failure.

EPO 2000S/2000X

Connection of single-phase 6 kVA system (use three EPO 2000X units)

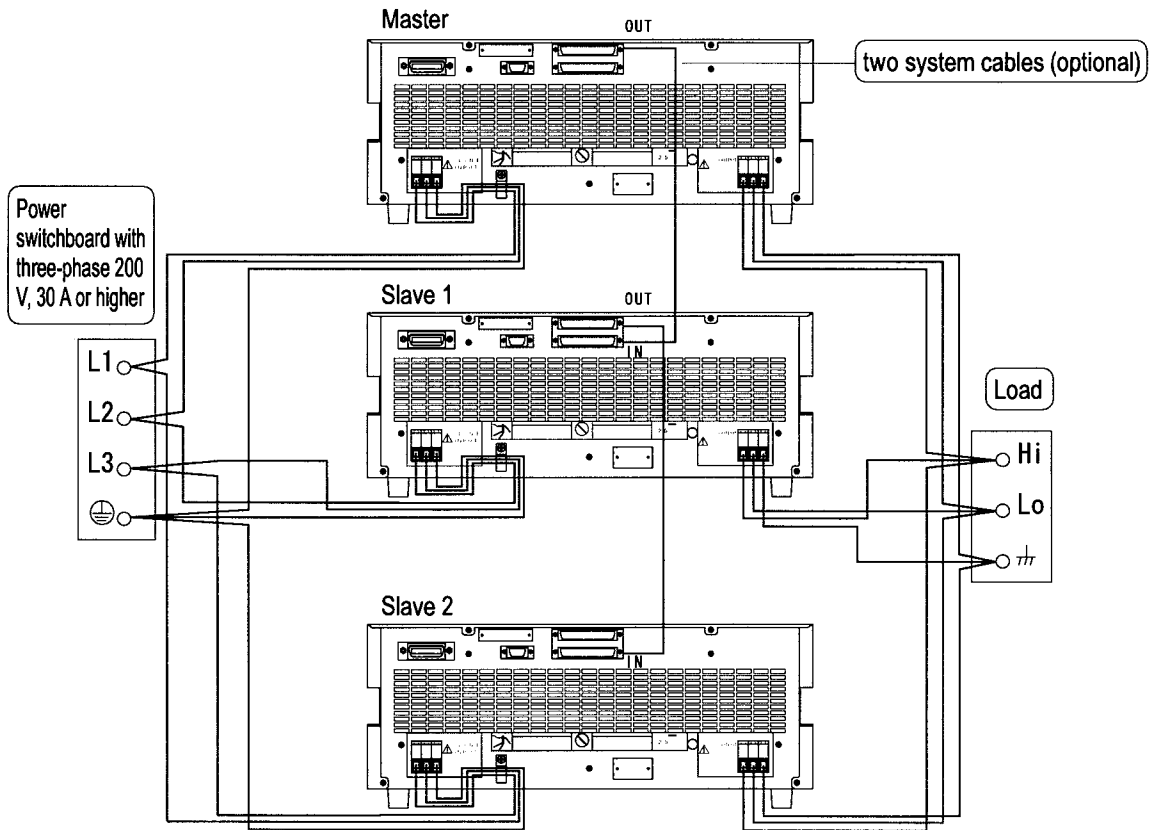

In the case of single-phase power input

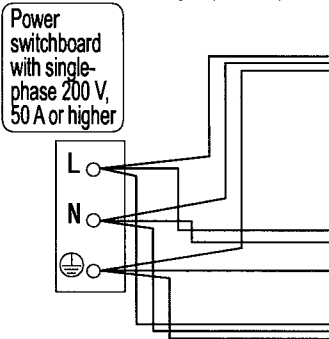

CAUTION

Fix the system cable by tightening the screws on the shield case securely.

Memo

Use of power input unit or output parallel unit for connection
 With a "Power Input Unit" (optional), it is possible to receive a single-phase 200 V power in package and supply the power to a system consisting of up to three units.
 With an "Output Parallel Unit" (optional), it is possible to connect up to three unit outputs in parallel to supply output from a single terminal block.

Connection of three-phase 6 kVA system (use three EPO 2000X units)

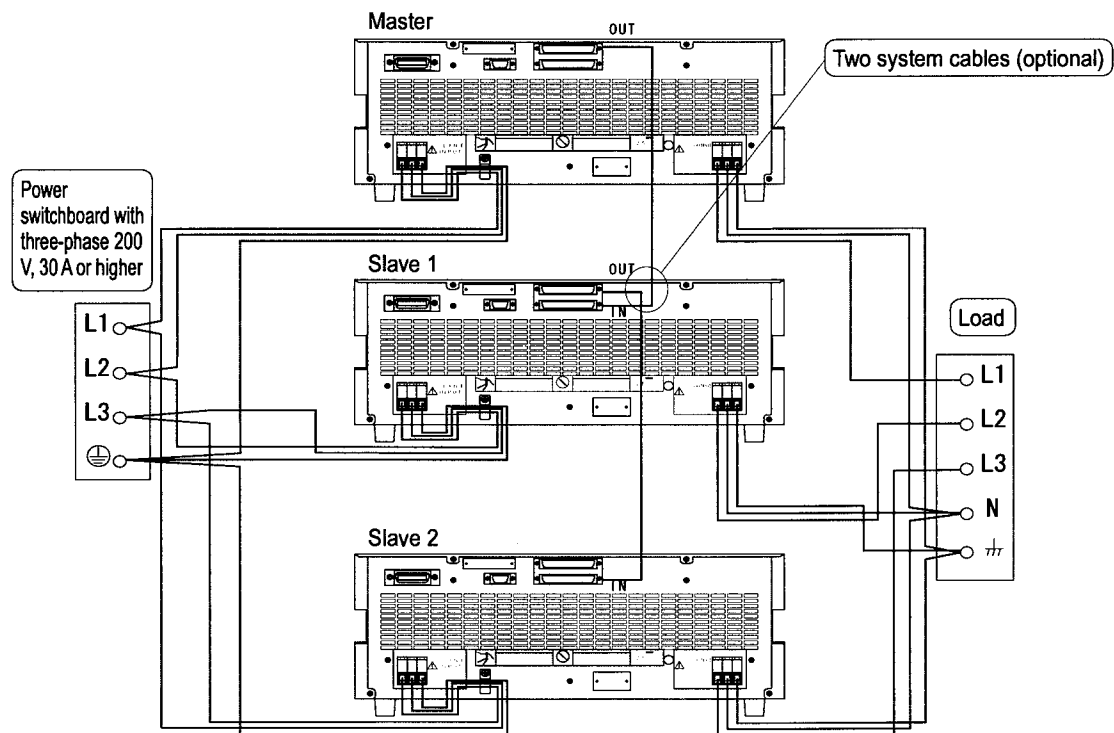

In the case of single-phase power

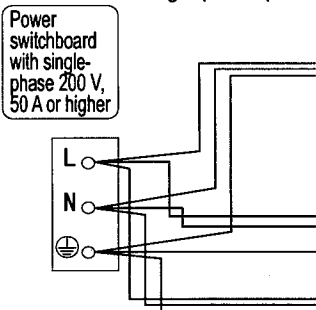

CAUTION

Use star connection for output. Delta connection cannot be used. Be sure to connect Lo terminal of the EPO 2000X output to the neutral point.



Memo

To deal with a three-phase three-wire load, make star connection as shown in the diagram using the terminal block or similar, then connect the load to L1, L2 and L3.

● 3. Installation and Connection ●

Connection of single-phase three-wire 4 kVA system (use two EPO 2000X units)

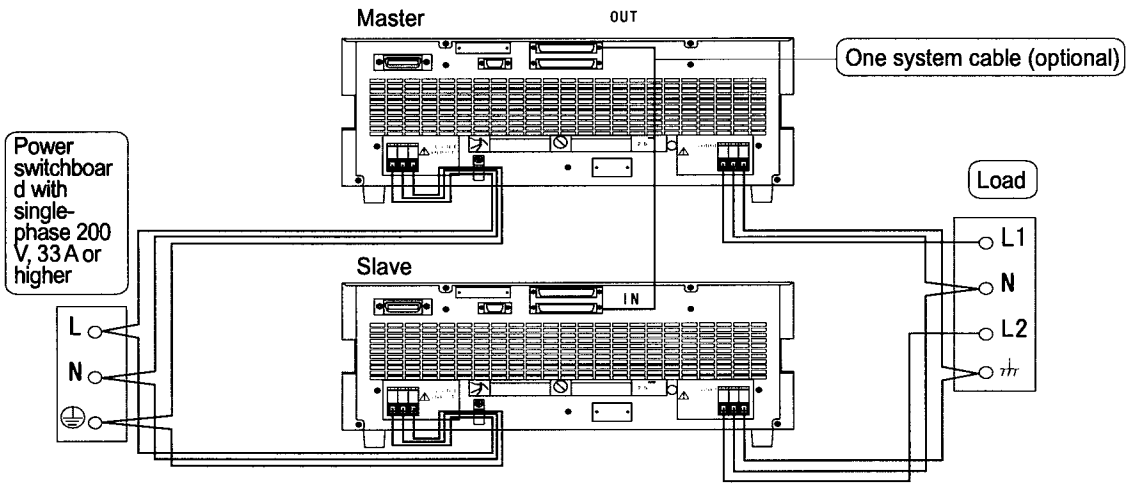

CAUTION

Fix the system cable by tightening the screws on the shield case securely.



Prior to starting operation

Since an EPO 2000S/EPO 2000X unit can provide a voltage of 300 Vac (424 Vdc) at the maximum, wrong operation may cause damage to the connected load or electric shock. Check the following items before starting operation.

(1) If this is the first operation of your unit, connect nothing to the output and you should try rehearsal operation referring to the instruction manual.

(2) Are you sure with the output connection? Confirm that proper cables are used to the maximum current.

(3) Are you sure with the power input connection? Confirm that our specified cables are used.

4

Fundamental Use - for beginners -

■ In this chapter, I explain fundamental use of the system. If this is the first time to use the system for you, please read this chapter first.

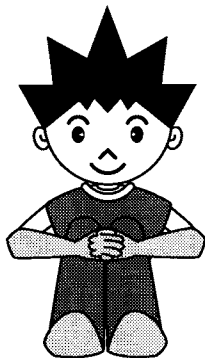

Attention!

This chapter particularly describes a system of single-phase 2 kVA (one EPO 2000S/EPO 2000X unit is used).

With an enhanced system that combines two or three EPO 2000X units, operation is partly different. For this configuration, refer to Chapter 6 "Use of Enhanced EPO 2000X System - increase the system output capacity or use units in a three-phase or single-phase three-wire configuration -".

Turning ON/OFF power supply

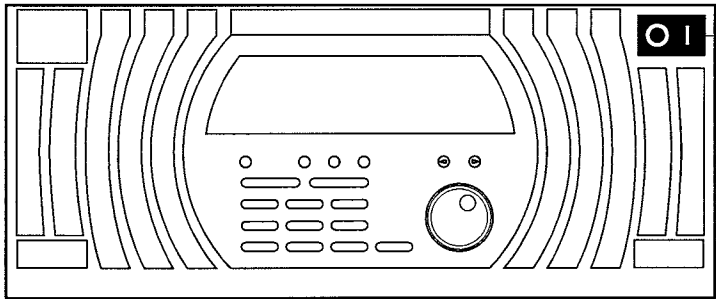

Power switch

- ▮ This side turns on the power supply when pressed.
- This side turns off the power supply when pressed.

Turning on the power

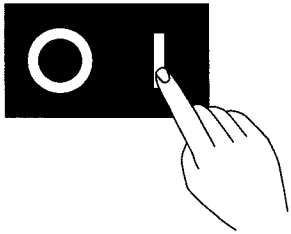

Press the ▮ side of the power switch.

All lamps light up and the display shows a running message.



Then a normal screen appears on the display.

Turning off the power



Press the ○ side of the power switch.

All indications go out. Cooling fan continues running for a moment until



Complete stop comes several seconds later.

Memo

- Just after the power energizing, the settings are those stored at Address 1 of the memory. You can enter familiar settings in Address 1 of the memory for your convenience in operation.
- You may turn on the power switch again when the cooling fan is running after power turning off. This causes no problem.

Setting the output voltage range

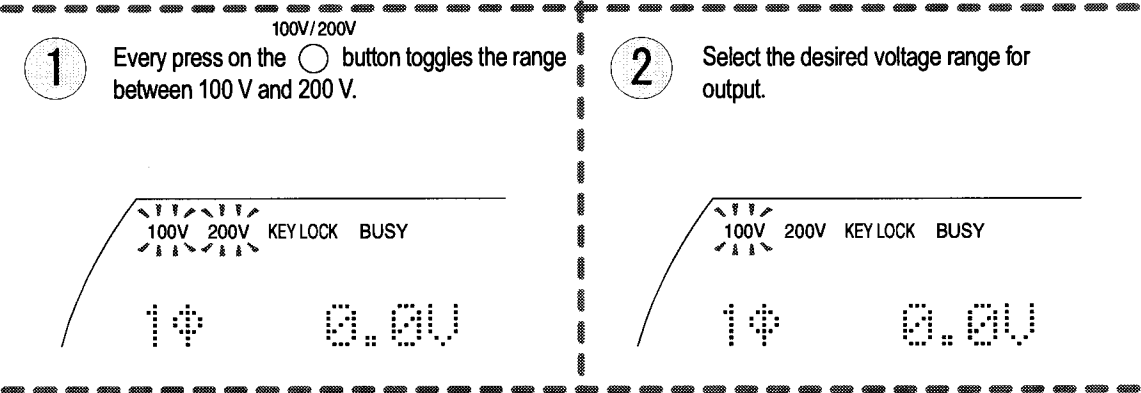
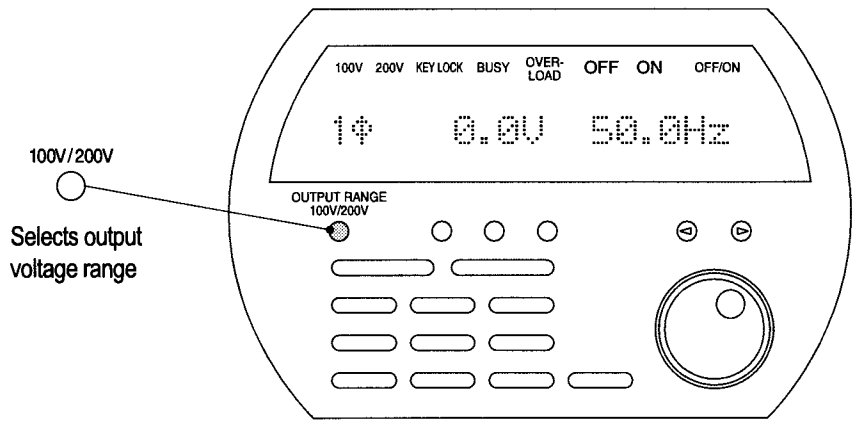

BUSY keeps lighting during the selection process; any button operation is not accepted at the moment.

Attention!

The maximum output current depends on the selected range.

Voltage range	Output range
100 V range	< 150V < 20A
200 V range	< 300V < 10A

Attention!

- When the range is changed, the output is turned off.
- If the setting of output voltage is out of the range of 100 V range, the 100 V range cannot be selected. Lower the voltage setting first before changing the range.

Setting the output voltage

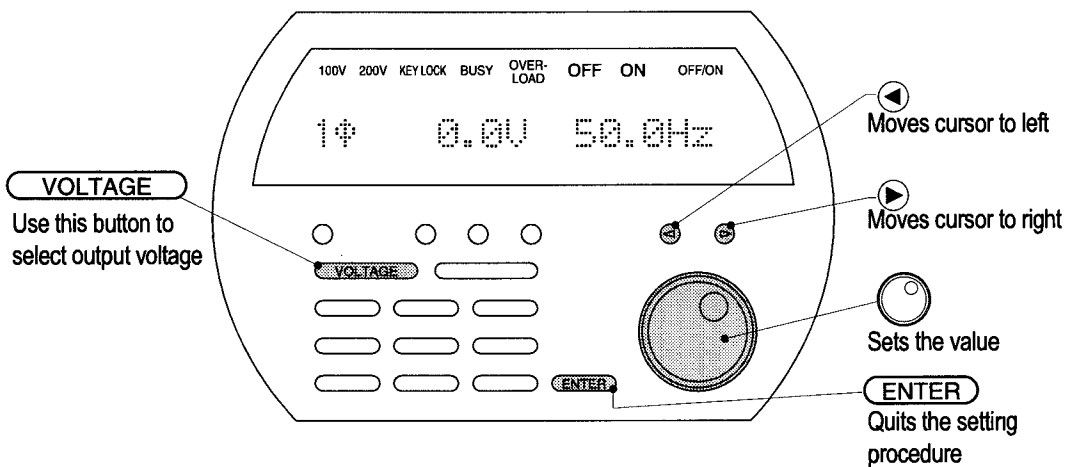

1 Press **VOLTAGE** and the voltage indication blinks.

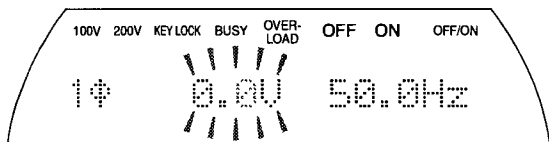

2 Press **◀** and **▶** to locate the cursor.

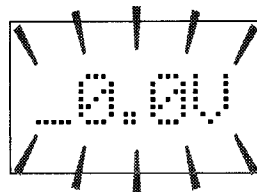

3 Turn **◯** to set the voltage.

- Clockwise turn increases the value.
- Counterclockwise turn decreases the value.

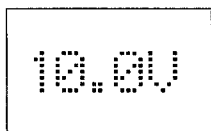

4 Press **ENTER** to quit the setting procedure.

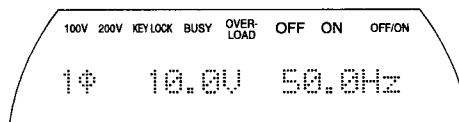

Memo

How to turn the rotary dial
[Moderate turn] [Quick turn]





Setting the output frequency

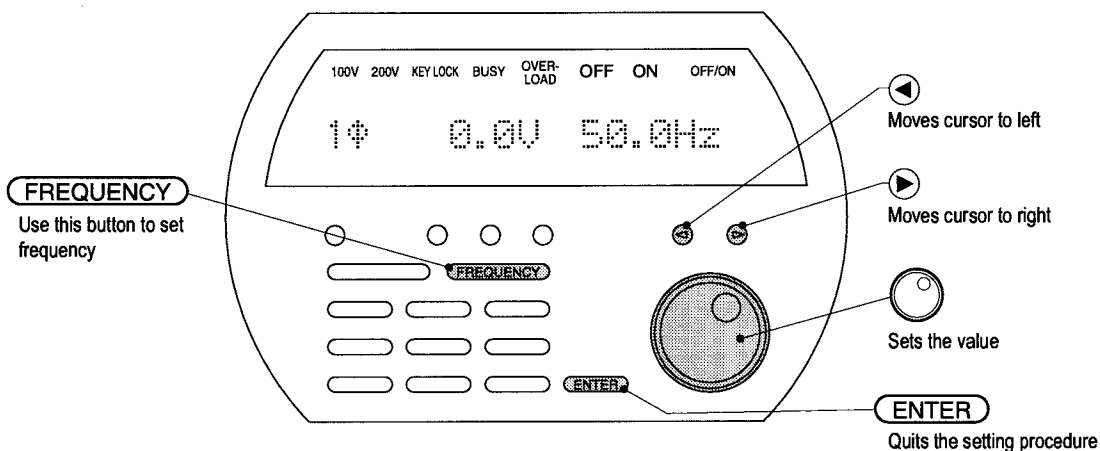

- 1 Press **FREQUENCY** and the frequency indication blinks.

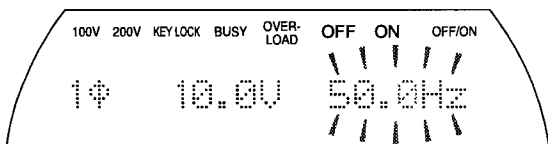

- 2 Press and to locate the cursor.

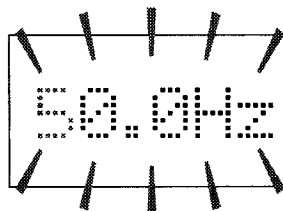

- 3 Turn to set the frequency.

- Clockwise turn increases the value.
- Counterclockwise turn decreases the value.

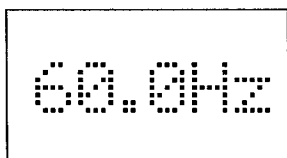

- 4 Press **ENTER** to quit the setting procedure.

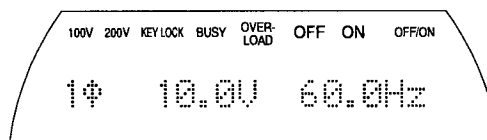

Turning ON/OFF the output

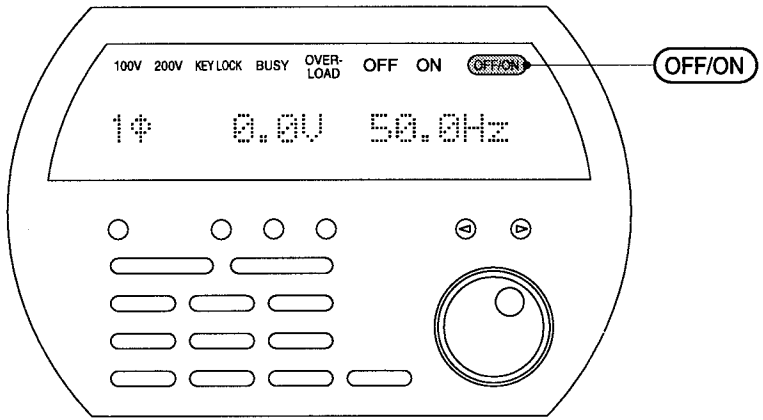

1 Every press on OFF/ON toggles the output between ON and OFF.

OFF ON OFF/ON

50.0Hz

BUSY keeps lighting during switching process.

BUSY OVER-LOAD OFF ON OFF/ON

0.00V 50.0Hz

Output is ON

ON keeps lighting.

OFF ON OFF/ON

Output is OFF

OFF keeps lighting.

OFF ON OFF/ON

EP0 2000S/2000X



Indication of overload

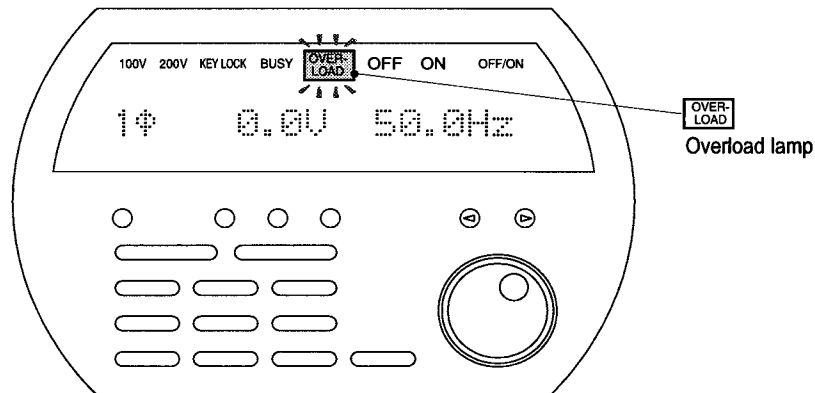

When output current exceeds the rated value, or if the output is short-circuited accidentally, control restrains the output current. The overload lamp keeps lighting during output restraint and the output voltage waveform is distorted.



Memo

This protective function will be automatically released when the cause is eliminated.
When a high current flows, for example, on motor startup, the system is temporarily set in an overload state.
When the current decreases to the rated value or lower, the normal output is restored, with the overload lamp going out.
However, the system may turn off the output to protect the internal circuit depending on the degree of overload.

Using measuring functions

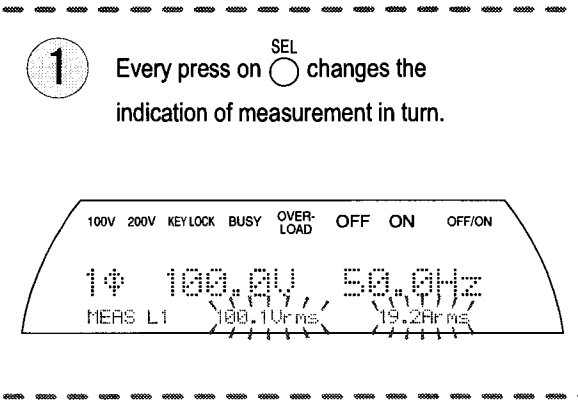
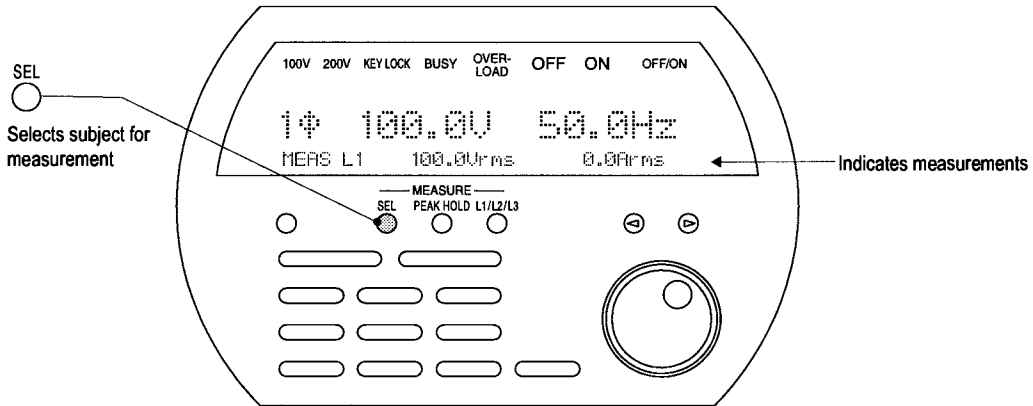

Measurements are shown in the bottom line of the display. The user can carry out setting while monitoring the real output value shown in the measurement field. The display shows the following values in turn:

- [RMS values of voltage and current]
- [Peak values of voltage and current]
- [Apparent power and effective power]
- [Power factor]

[Example]

RMS values of voltage and current		
MEAS L1	100.1Vrms	19.2Arms
Peak values of voltage and current		
MEAS L1	141.6Vpk	27.2Apk
Apparent power and effective power		
MEAS L1	1.92kVA	1.92kW
Power factor		
MEAS L1		PF 1.000

Attention!

- The measurement range is automatically changed by detection of the peak values of the voltage and current RMS values.
- The measurement range cannot be fixed.

Attention!

- Voltage and current are measured properly only when the frequency is in the range of 40 to 500 Hz.
- Effective power is measured properly only when the frequency is in the range of 45 to 65 Hz.

Memo

- The display shows the peak value in positive or that in negative whichever is greater.
- Apparent power and power factor are determined through calculation from other measurements.

EP0 2000S/2000X



Setting limits to output

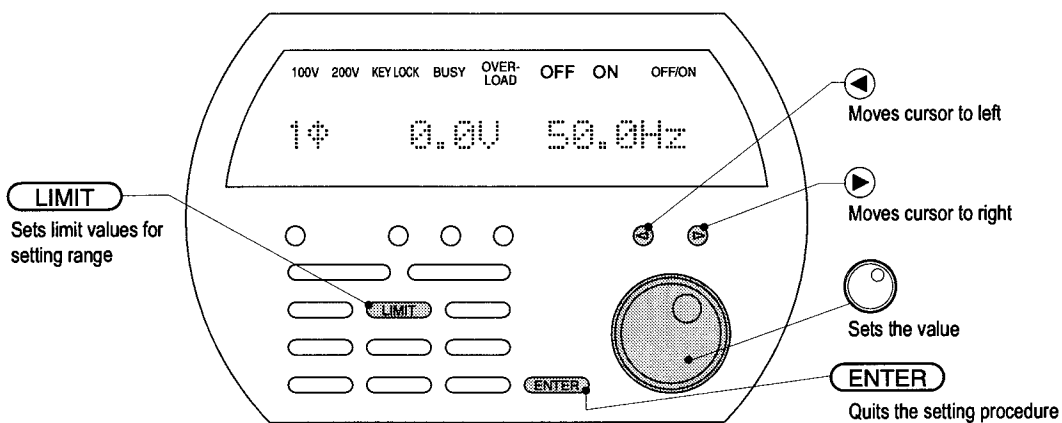

Setting of limit values can limit the setting range of output voltage and output frequency. If the user sets in advance a limit(s) according to the allowable input range of the connected load, it can prevent failure of the load caused by application of excessive voltage or other factors.

Three types of limits are available for setting: upper limit to output voltage, upper limit to output frequency, and lower limit to output frequency.



Memo

Once a limit value is entered, press **ENTER** to quit the setting procedure, and the display returns to the normal screen. If you want to enter another limit setting, then press **LIMIT** instead of **ENTER** and go to the next limit entry.

Setting an upper limit to output voltage

- 1 Press **LIMIT**, and the display shows a screen for setting an upper limit to output voltage.

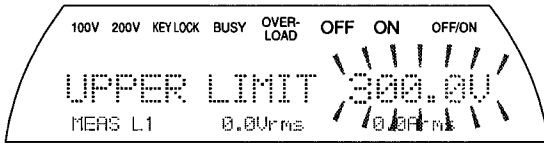

- 2 Press **◀** and **▶** to locate the cursor.

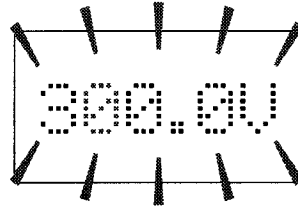

- 3 Turn **⦿** to set the desired upper limit to the output voltage.

- Clockwise turn increases the value.
- Counterclockwise turn decreases the value.

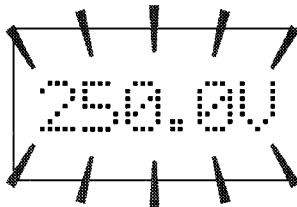

Press **ENTER** to quit the setting procedure.

Setting an upper limit to output frequency

- 1 While the display keeps showing the screen for setting an upper limit to output voltage, press **LIMIT**, and the display shows a screen for setting an upper limit to output frequency.

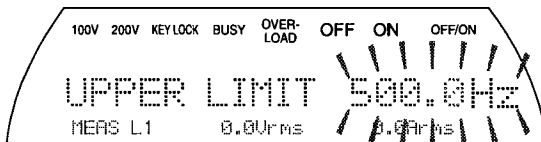

- 2 Press **◀** and **▶** to locate the cursor.

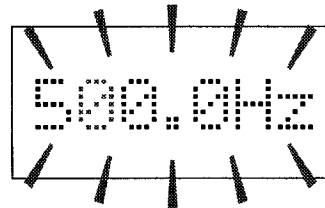

- 3 Turn **⦿** to set the desired upper limit to the output frequency.

- Clockwise turn increases the value.
- Counterclockwise turn decreases the value.

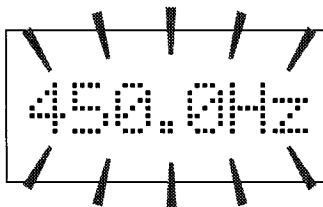

Press **ENTER** to quit the setting procedure.

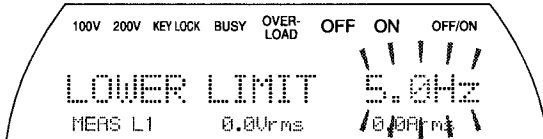

Setting a lower limit to output frequency

- 1 While the display keeps showing the screen for setting an upper limit to output frequency, press **LIMIT**, and the display shows a screen for setting a lower limit to output frequency.

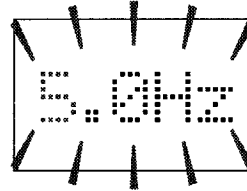

- 2 Press **◀** and **▶** to locate the cursor.



- 3 Turn  to set the desired lower limit to the output frequency.
-  Clockwise turn increases the value.
 -  Counterclockwise turn decreases the value.

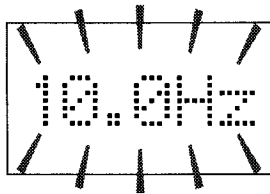

- 4 Press **LIMIT** or **ENTER** to quit the setting procedure and the display returns to the normal screen.

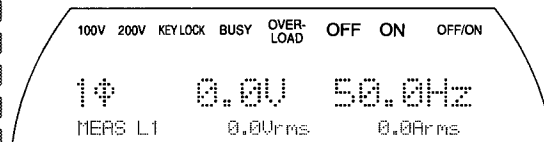

Attention!

When setting a voltage limit value, you cannot specify a value that is lower than the already set output voltage. Similarly for output frequency limit value, you cannot make setting that will exclude the then set frequency from the intended range.



Attention!

When the system is in a line-synchronized condition or in DC output mode, setting a limit to output frequency is not available. (In the above situation, only output voltage upper limit can be set with **LIMIT**.)

5

Versatile Use - for advanced users -

- In this chapter, I will explain versatile use of the system.



Using the unit as a DC power supply

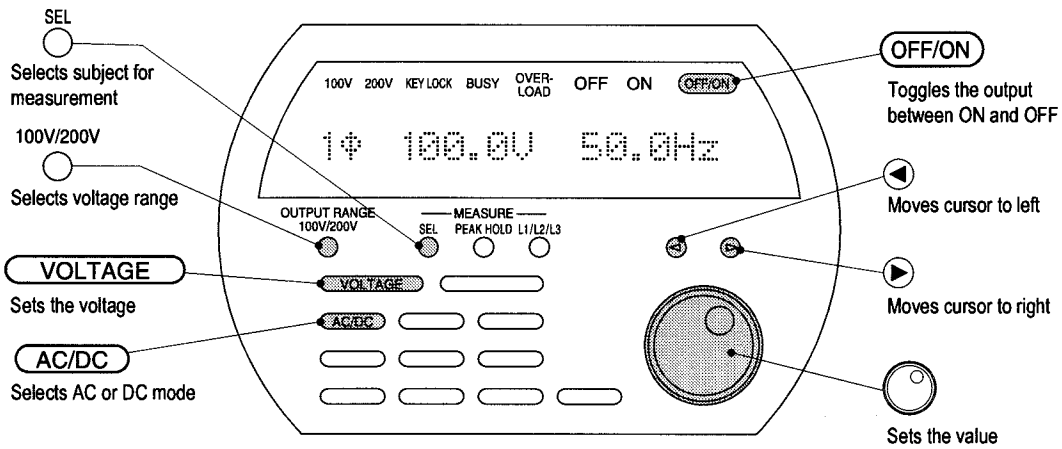

Selecting DC output mode

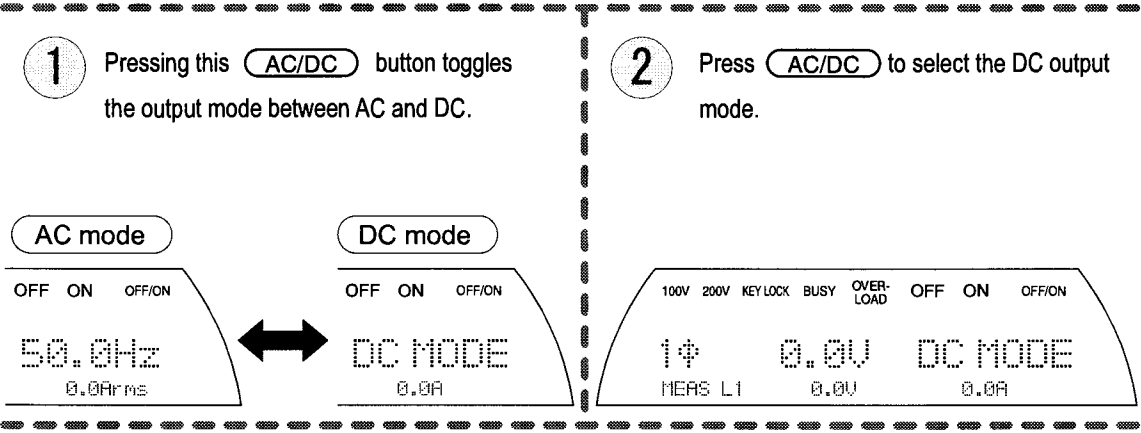

Memo

- The unit supplies only AC current in AC output mode and DC current in DC output mode.

Attention!

- The output mode cannot be switched to DC when line synchronization is enabled.
- The output mode cannot be switched to DC when the system is in three-phase mode or single-phase three-wire mode.
- Output will be turned off if AC/DC switching operation is attempted while output current is supplied.

EPO 2000S/2000X

● 5. Versatile Use ●

Setting an output voltage range

- 1 This button toggles the output voltage range between 100 V and 200 V.

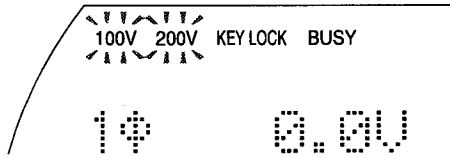

- 2 Press to select the desired voltage range.

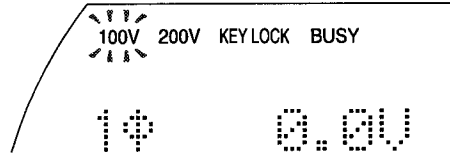

Attention!

The maximum output current depends on the selected range as follows:

Voltage range	Maximum output power	Maximum voltage	Rated voltage	Maximum output current
100 V range	1270W	212.0V	141.0V	9A
200 V range		424.0V	282.0V	4.5A

For EPO 2000X units:

* The maximum output power and maximum output current in the above table are values for a single EPO 2000X unit system. The values will be twice the shown values if two EPO 2000X units are used, and three times if three units are used.

Setting an output voltage

- 1 Press **VOLTAGE**, and the voltage indication will blink.

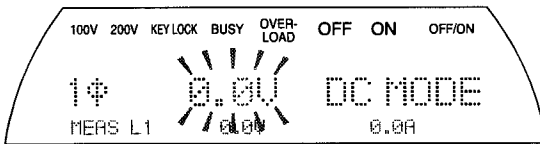

- 2 Press **◀** and **▶** to locate the cursor.

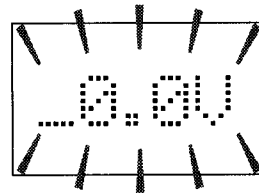

- 3 Turn to set the desired voltage.
- Clockwise turn increases the value.
 - Counterclockwise turn decreases the value.

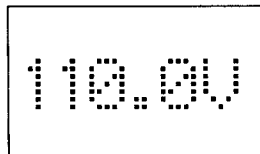

- 4 Press **OFF/ON** to turn ON the output.

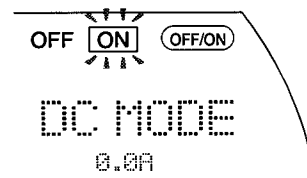

Using the measurement functions

- 1 Every press on  changes the indication of measurement in turn.

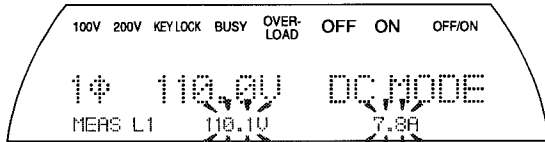

Measurements are shown in the bottom line of the display.

* Measurements of "Voltage", "Current" and "Power" are displayed when in DC output mode.

[Example] Mean value of voltage and current

MEAS L1	110.1V	7.8A
Effective power		
MEAS L1		0.86kW



Attention!

- The measurement range is switched automatically.
- The measurement range cannot be fixed.



Attention!

- Mean values are displayed for voltage and current in DC output mode, and AC components are not measured.



Memo

- If the current contains an AC component, a peak value will be detected and this switches the DC measurement range to a higher range.

Settings for output compensation mode

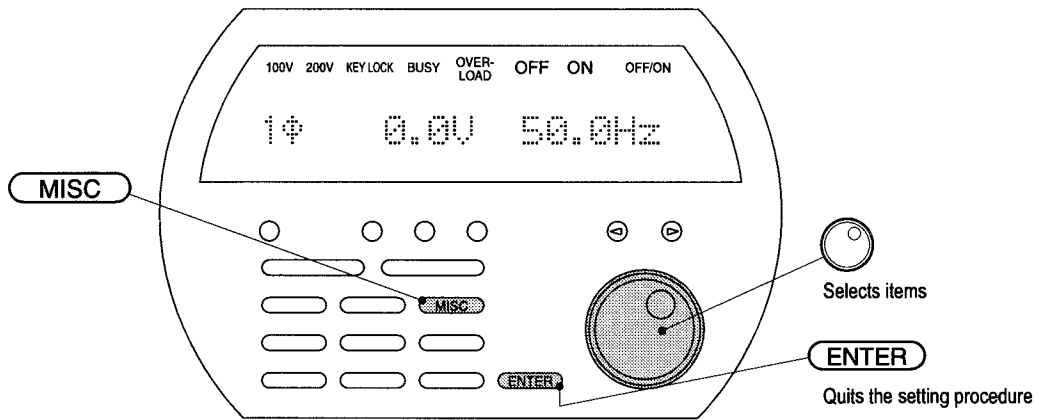

This function selects a high or low level of the compensation sensitivity to maintain the output voltage at a constant value against load current and its fluctuation.

If you select high sensitivity (or precision), then high-precision control is secured against the fluctuation of load current, with the variation of the output voltage restrained to a low level. However, this tends to allow unstable operation under a high capacitive load (e.g., capacitor).

If you select low sensitivity (or high stability), on the contrary, improved stability can be maintained under a capacitive load although the output voltage fluctuates in a wider range.

The unit is set to low sensitivity (or high stability) on shipping.

Selecting low sensitivity (or high stability)

- 1 Press **MISC** couples of times until an output compensation mode setting screen appears.

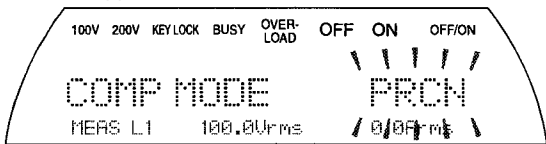

- 2 Turn the dial and select HSTB.

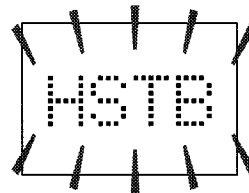

- 3 Press **ENTER** to quit the selection procedure, and the display returns to the normal screen.

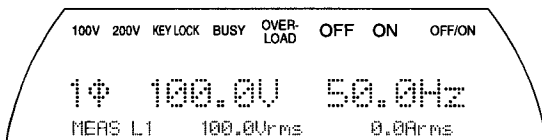

Selecting high sensitivity (or precision)

- 1 Press **MISC** couples of times until an output compensation mode setting screen appears.

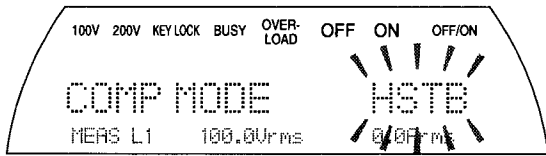

- 2 Turn the dial  and select PRCN.

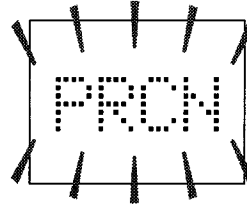

- 3 Press **ENTER** to quit the selection procedure, and the display returns to the normal screen.

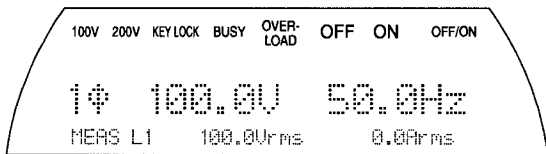

Memo

[Stability under capacitive load]

The upper limit of capacitive load that allows stable control is about $5 \mu\text{F}$ in precision mode. In high stability mode, the unit allows stable control up to $150 \mu\text{F}$ or so.



Memo

If a line filter is used in an RF anechoic chamber, select high stability mode.



Memo

To reduce waveform distortion near a voltage peak under the load of the capacitor input type rectifier, use the equipment in precision mode.

Using storage function

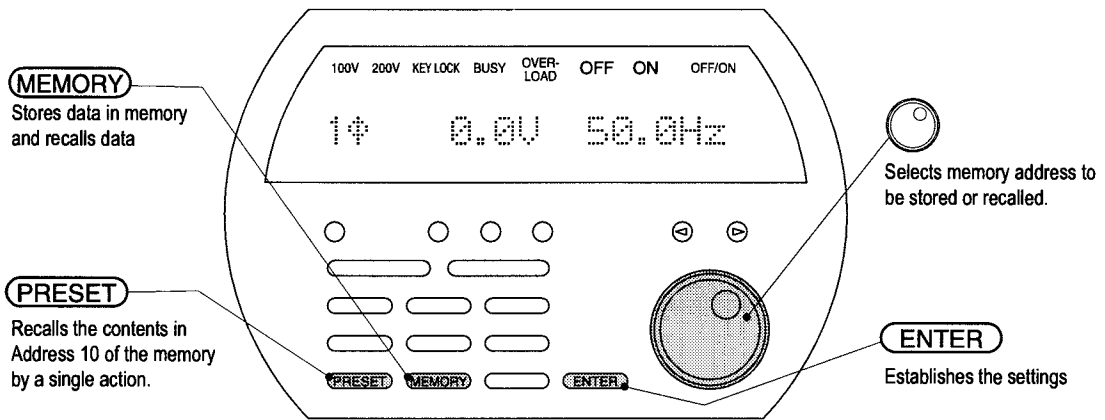

This function stores setting values or statuses. Pieces of data are stored in the incorporated memory backed up by a battery, and they can be recalled as necessary.

Storing settings

5. Versatile Use

1 Press **MEMORY** once, and a store execution screen appears.

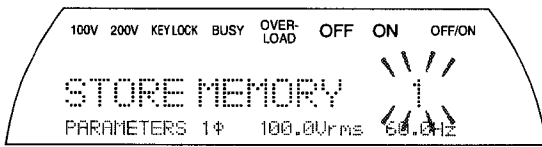

2 Turn the dial to select the desired memory address (from 1 to 10).

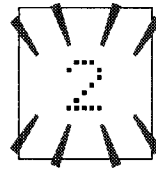

3 Press **ENTER** and the current status is stored and the display returns to the normal screen.

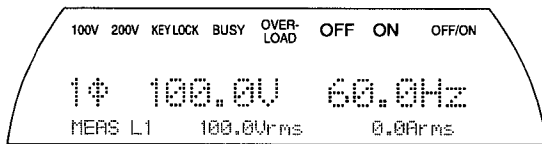

Attention!

The unit has eleven memory addresses from 0 to 10. Addresses 1 to 10 allow the user to store a desired specified status. The user can recall Address 0 to reduce all settings in the memory to those set on shipping. Address 0 does not allow the user to store any data.

Recalling settings

- 1 Press **MEMORY** twice, and a recall execution screen appears.

* Repeat pressing **MEMORY**, and the display shows in turn a store execution screen, a recall execution screen, and the normal screen.

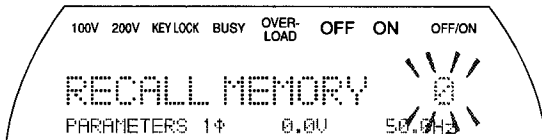

- 2 Turn the dial  to select the desired memory address (from 0 to 10).

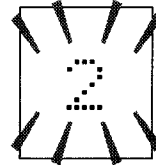

- 3 The bottom line of the display shows the phase mode, output voltage, and output frequency stored at that address.

* Phase mode: 1 ϕ , 2 ϕ , and 3 ϕ stand for single-phase, single-phase three-wire and three-phase, respectively.

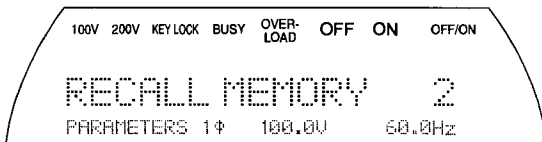

- 4 Press **ENTER** and the data at the address is recalled and then the display returns to the normal screen.

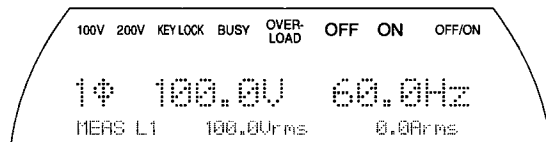

Recalling at one action with preset key

- 1 Press **PRESET**, and the data stored at Address 10 is recalled.

[Example]

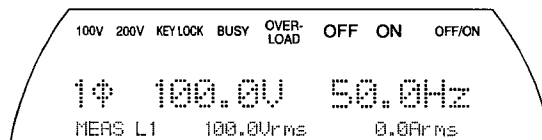

Memo

Store your favorite (or frequently used) settings or status at Address 10. You can press **PRESET** to retrieve the data immediately.

Retrieving on-shipping settings

- 1 Recall Address 0 of the memory to reinstate the unit into the status of settings made on shipping.



Memo

When the unit is powered, the settings stored at Address 1 are automatically recalled. Thus, if the status of normal operation is stored at Address 1, you will be released from the setting works every time in the beginning of operation.



Memo

Use of the optional numeric keypad enables the user to recall any of Addresses 1 to 9 with a single button action.
This will be useful in operation of inspecting power voltage range.

Setting items for memory storage and on-shipping settings

Setting items		On-shipping settings
Output voltage range	AC	100 V range
	DC	100 V range
Output voltage	AC	0.0[V]
	DC	0.0[Vdc]
AC voltage setting mode		Phase-voltage setting
Output frequency		50.0[Hz]
Selection of AC/DC output mode		AC output mode
Output compensation mode		High stability
ON/OFF of line synchronization		OFF
Resetting frequency from line synchronization		50.0[Hz]
Limit value	Upper limit to AC phase voltage	300.0[V]
	Upper limit to AC line-to-line voltage (three-phase)	519.6[V]
	Upper limit to AC line voltage (single-phase three-wire)	600.0[V]
	Upper limit to DC voltage	424.0[Vdc]
	Upper limit to frequency	550.0[Hz]
	Lower limit to frequency	5.0[Hz]
Power-on phase when output is ON		0[deg]
Phase mode		Single-phase mode



Attention!

When any memory is recalled, the output is always turned OFF for safety reason. Depending on settings, however, memory can be recalled with the output maintained ON. This function can be used to quickly change the output voltage or frequency against the load.

(Settings for memory recall with the output kept ON)

Ⓢ Before and after memory recall, the following parameters must be the same:

- (1) AC/DC output mode
- (2) Line-synchronization status
- (3) Output voltage range



Attention!

- In an EPO 2000X unit, you cannot recall the address at which different phase mode is stored. Such operation will be ignored.
- Note that contents in the memory of the master unit will be cleared when system cable connection is altered.

Measuring rush current

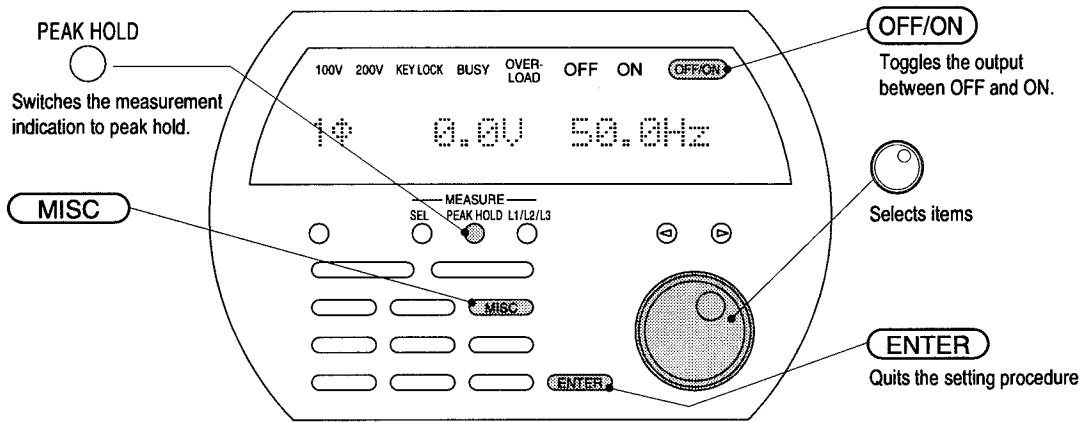

This function can measure the amount of rush current flowing in a load such as a cleaner and air conditioner that entails a rush current flow.

In addition, the user can observe the change in the flow of rush current because the system allows the user to set the power-on phase at the time of output turn-on by the step of 90 degrees.

Setting the power-on phase on output turn-on

1 Press **MISC** couples of times until a power-on phase setting screen appears.

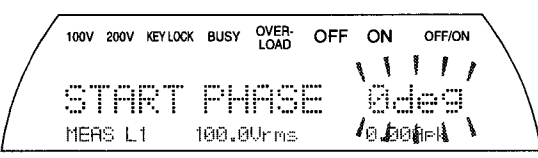

2 Turn the dial and select the desired power-on phase.

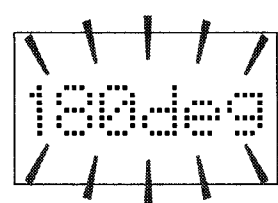

3 Press **ENTER** to establish the setting, and the display returns to the normal screen.

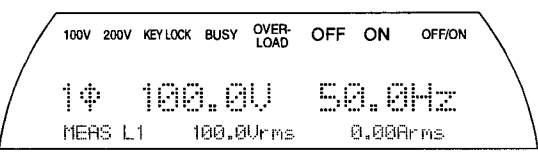

You can select the power-on phase out of 0, 90, 180 and 270 degrees.

Using the peak hold function

- 1** Press when the output remains turned OFF.

* The measurement indication in the bottom line of the display changes to peak hold (PEAK HOLD).

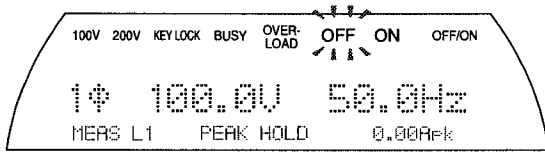

- 2** Press the **OFF/ON** button to turn ON the output, and the display shows the maximum value of the rush current that flowed at the moment.

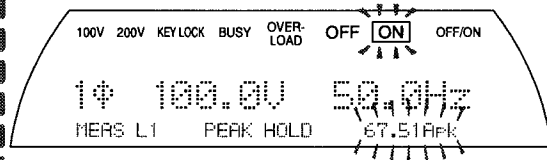

- 3** Press , and the display returns to the normal screen.

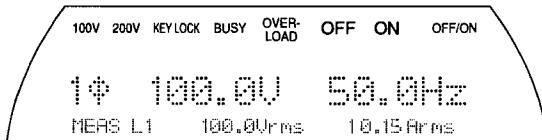

Attention!

This peak current holding function shows the maximum value out of the peak values detected during the five cycles after turning on the output.

Therefore, normal measurement may not be achieved if you try to detect the peak current through ON/OFF operation on the load with the output being kept ON.

6

Use of Enhanced EPO 2000X System

- increase the system output capacity or use units in a three-phase or single-phase three-wire configuration -

■ With the optional system cable, you can combine up to three EPO 2000X units to enhance the system capacity. In this chapter, I will explain the necessary operation for the above configuration.



Attention!

- The operation described in this chapter is applicable to EPO 2000X only.
- EPO 2000S units cannot be used in the system enhancement, not even through combination of EPO 2000S and EPO 2000X units.

What functions are available by system enhancement?

Two combined EPO 2000X units can provide a single-phase/single-phase three-wire 4 kVA power supply while three combined EPO 2000X units can provide a single-phase/three-phase 6 kVA power supply.

Number of EPO 2000X units	Number of optional system cables required	Systems available	DC output mode	Remarks
2	1	Single-phase 4 kVA	Yes	
		Single-phase three-wire 4 kVA	No	
3	2	Single-phase 6 kVA	Yes	
		Three-phase 6 kVA	No	
		Single-phase three-wire 4 kVA	No	The third unit is inoperative.

DC output mode is available only in single-phase mode.

Connection of system cable

In a system consisting of two or more units, one of EPO 2000X units will be the master and others will be slaves. The status of the master or slave depends on the connection of system cable.

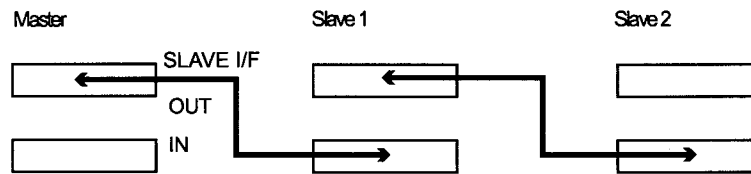

Phase mode

The phase modes of system include three modes: single-phase, single-phase three-wire and three-phase. The phase mode of the system is shown on the master's display.

Indication	Phase mode
1 ϕ	Single-phase
2 ϕ	Single-phase three-wire
3 ϕ	Three-phase

Once the units are connected with a system cable(s), the phase mode of the system can be changed on the master unit. To change the phase mode, it is necessary to first make setting, then turn off the power and turn it on again.

Restrains on memory

If the system cable connection is modified, the contents stored in the master's memory will be initialized. However, slave's memory will not be changed.

If the phase mode is modified, the contents in the memory will not be changed. However, the phase mode at Adders 1 of the master unit will be rewritten with the phase mode that was newly set.

If the stored phase mode differs from the current phase mode, the memory cannot be recalled.

Using the system as a single-phase 4 or 6 kVA power supply

If two or three EPO 2000X units are connected with an optional system cable(s), a single-phase 4 or 6 kVA power system will be achieved.
 Refer to Chapter 3 "Installation and Connection" first and carry out proper connection over two or three EPO 2000X.

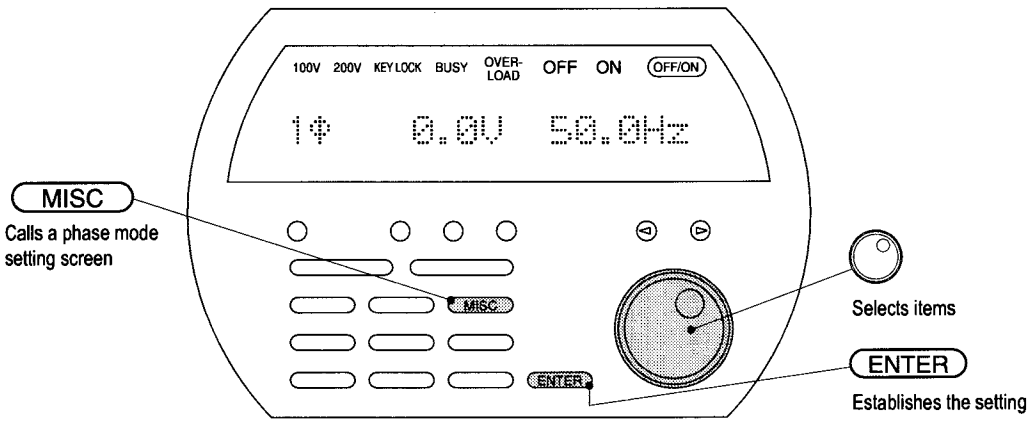

Turning ON/OFF the power

1 Turn ON the power switches on all EPO 2000X units.

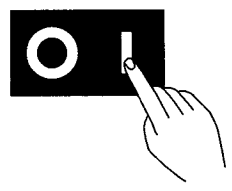

2 The system will be available as a single-phase 4 (or 6) kVA power supply, with only the master unit being operable.

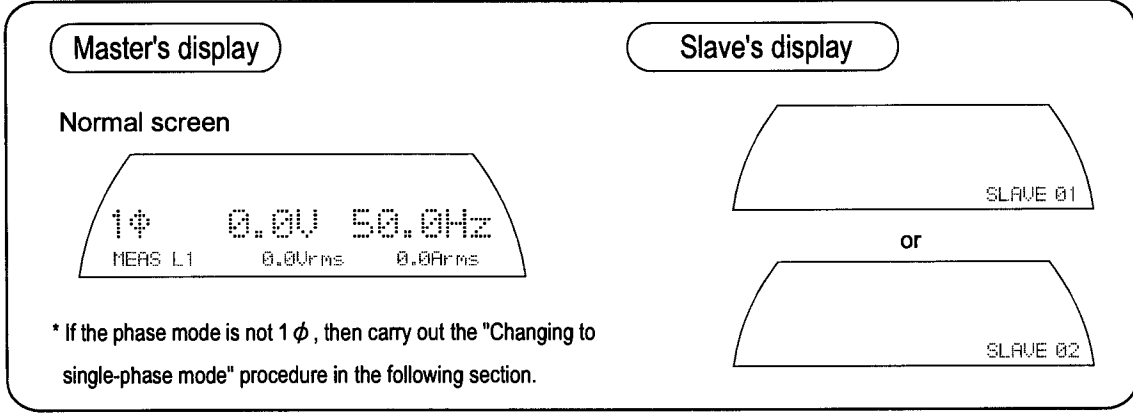
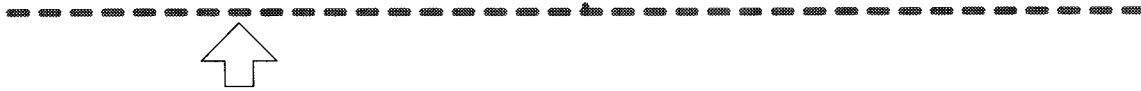

- 3 To shut off the power input, turn off the power switch on each EPO 2000X unit.



Attention!

- Power switches may be turned on in any order. However, all switches must be turned on within 15 seconds to secure normal startup. If you failed in this, turn off all switches then turn them on again after several seconds.
- Power switches may be turned off in any order as well.



Memo

- Operation is performed only on the master's panel.
- On slave's panel, any operation will not be accepted.

Changing to single-phase mode

- 1 Press **MISC** couples of times until a phase setting screen appears.

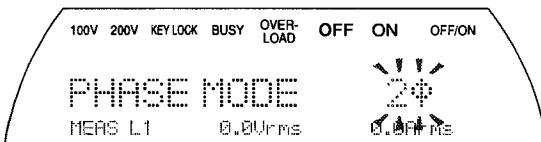

- 2 Turn the dial and select 1 φ .

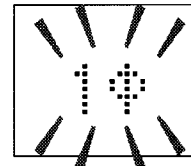

- 3 Press **ENTER** , and a message will prompt you: "Please RESTART".

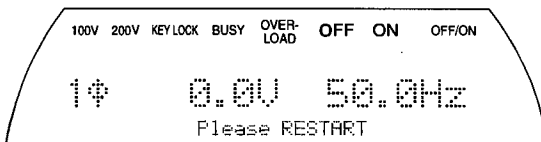

The indication denotes the phase mode of "single-phase", "single-phase three-wire" and "three-phase" as follows:

Indication	Phase mode
1 φ	Single-phase
2 φ	Single-phase three-wire
3 φ	Three-phase

At this moment, any button is not operable.

- 4 Turn off the power switches on all the EPO 2000X units.



- 5 When all indications have disappeared, turn on all power switches.

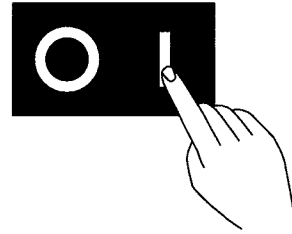

- 6 The system is started in single-phase mode afresh.

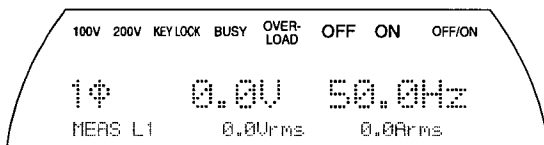

Attention!

When the power is turned on, the system starts up with the contents stored at Address 1 of the memory. Just after the change of phase mode, the phase mode field at Address 1 is rewritten with the newly selected phase mode.

Store afresh the status of normal use into Address 1.

Using the system as a three-phase 6 kVA power supply

If three EPO 2000X units are connected with optional system cables, a three-phase 6 kVA power system will be achieved.

The output voltage can be set via the phase voltage or line-to-line voltage.

Refer to Chapter 3 "Installation and Connection" first and carry out proper connection over three EPO 2000X.

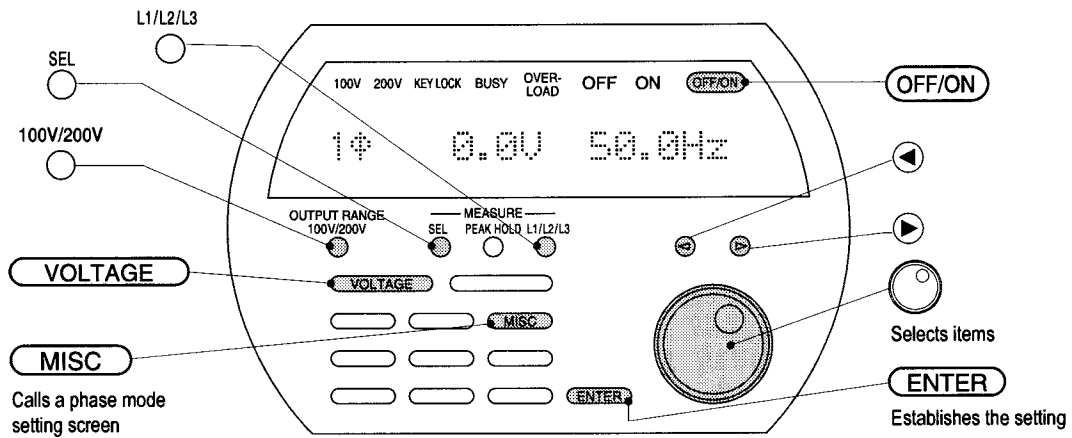

EPO 2000S/2000X

Turning ON/OFF the power

- 1 Turn ON the power switches on all EPO 2000X units.

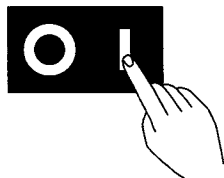

- 2 The system will be available as a three-phase 6 kVA power supply, with only the master unit being operable.

Master's display

Normal screen

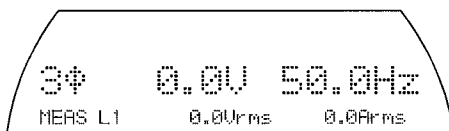

* If the phase mode is not 3 ϕ , then carry out the "Changing to three-phase mode" procedure in the following section.

Normal screen



or



- 3 To shut off the power input, turn off the power switch on each EPO 2000X unit.



Attention!

- Power switches may be turned on in any order. However, all switches must be turned on within 15 seconds to secure normal startup. If you failed in this, turn off all switches then turn them on again after several seconds.
- Power switches may be turned off in any order as well.



Memo

- Operation is performed only on the master's panel.
- On slave's panel, any operation will not be accepted.

Changing to three-phase mode

- 1 Press **MISC** couples of times until a phase setting screen appears.

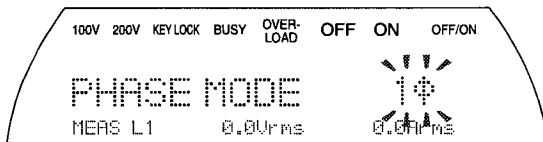

- 2 Turn the dial  and select 3 ϕ .

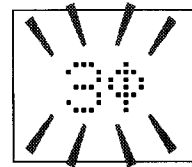

- 3 Press **ENTER**, and a message will prompt you: "Please RESTART"

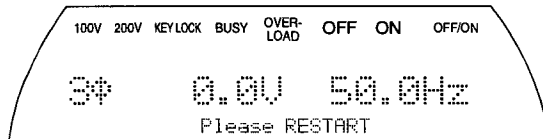

The indication denotes the phase mode of "single-phase", "single-phase three-wire" and "three-phase" as follows:

Indication	Phase mode
1 ϕ	Single-phase
2 ϕ	Single-phase three-wire
3 ϕ	Three-phase

At this moment, any button is not operable.

- 4 Turn off the power switches on all the EPO 2000X units.



- 5 When all indications have disappeared, turn on all power switches.

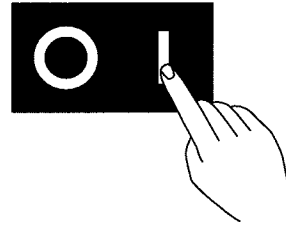

- 6 The system is started in three-phase mode afresh.

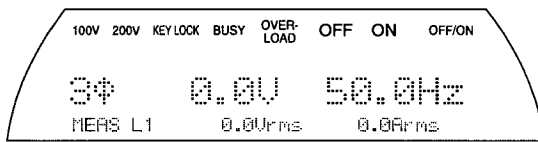

Attention!

When the power is turned on, the system starts up with the contents stored at Address 1 of the memory. Just after the change of phase mode, the phase mode field at Address 1 is rewritten with the newly selected phase mode.

Store afresh the status of normal use into Address 1.

Exemplary voltage setting: supplying three-phase 200 V output

- 100V/200V
- 1 Press on the master unit to select the voltage range.

* To supply three-phase 200 V (line-to-line voltage of 200 V) output, select the 100 V range.

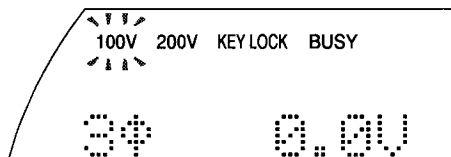

- 2 Repeat pressing **VOLTAGE** on the master unit, and the display toggles showing a "Phase voltage setting" and "Line-to-line voltage setting" screens while the voltage indication blinks.

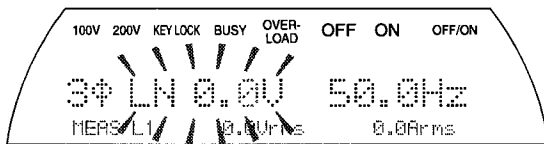

- 3 Press and to locate the cursor.

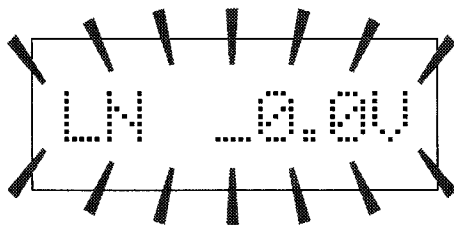

- 5 Press **OFF/ON** to turn on the output.

* Now the system is ready to provide three-phase power.



Attention!

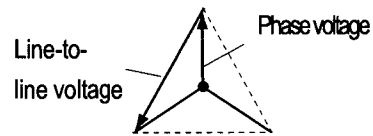

Voltage range	Maximum phase voltage	Maximum line-to-line voltage
100 V range	150.0V	259.8V
200 V range	300.0V	519.6V

Phase voltage setting

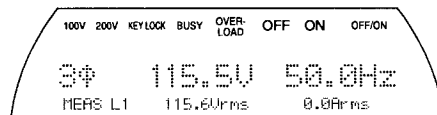

Line-to-line voltage setting

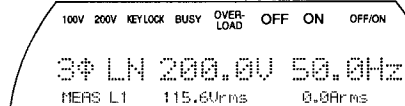

- 4 Turn the dial to select the desired output voltage.

* To supply three-phase 200 V output, select 115.5 V in phase voltage or 200.0 V in line-to-line voltage.

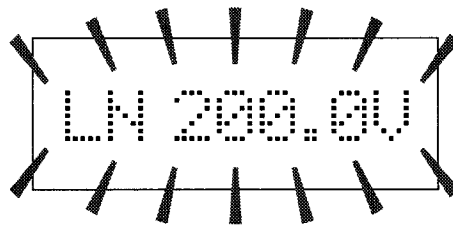

Memo

- If voltage setting is selected in line-to-line voltage, then the normal screen and the upper limit to output voltage are also shown in line-to-line voltage.
- Line-to-line voltage setting is made in 0.2 V resolution.

Using a measuring function in three-phase configuration

This function measures and displays "RMS value of voltage and current", "peak value of voltage and current", "apparent power", "effective power", and "power factor".

It is possible to change the phase of measurement.

1 Every press on  shows in turn different measurements in the bottom line as follows:

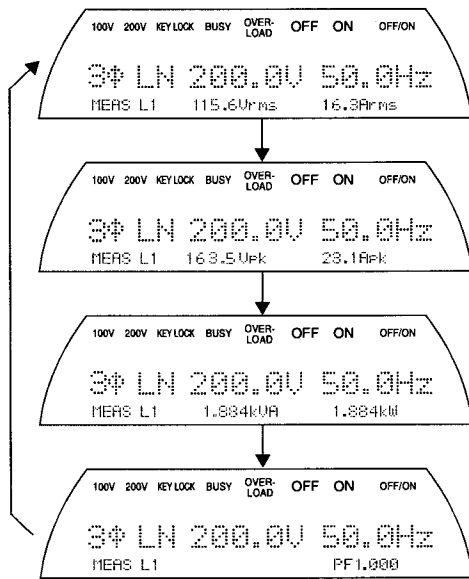

2 A press on  changes the phase of measurement.

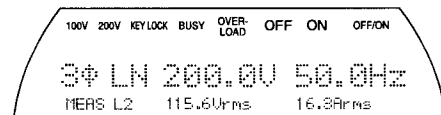

Different measurements are displayed one after another as shown below.

Measurement phase changes by press on 	Indication of measurements			
	Vrms, Arms	Vpk, Apk	kVA, kW	PF
L1	L1-phase voltage, L1-phase current		L1-phase apparent power L1-phase effective power	L1-phase power factor
L2	L2-phase voltage, L2-phase current		L2-phase apparent power L2-phase effective power	L2-phase power factor
L3	L3-phase voltage, L3-phase current		L3-phase apparent power L3-phase effective power	L3-phase power factor
L1-L2	L1-L2 line-to-line voltage, L1-phase current		Phase-total apparent power Phase-total effective power	All-phase power factor
L2-L3	L2-L3 line-to-line voltage, L2-phase current			
L3-L1	L3-L1 line-to-line voltage, L3-phase current			

Different functions in three-phase mode

Output limit setting	If the normal screen is shown in line-to-line voltage, the upper limit to output voltage is also indicated and can be set in line-to-line voltage.
DC output mode	Not available.
Storage function	Recall is not possible to the address at which different phase mode is stored.
Setting the power-on phase on output turn-on	L1-phase power-on phase can be set.
Peak current retaining function	Measurement is available similarly to that in single-phase mode. The phase of measurement can be changed as well.

Phase indication and phases

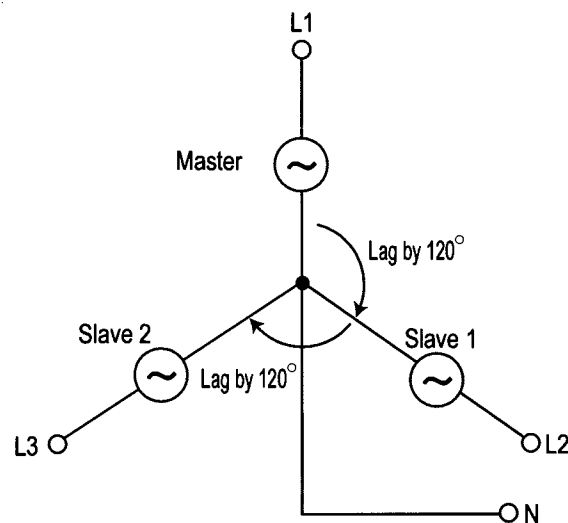

Using the system as a single-phase three-wire 4 kVA power supply

If two EPO 2000X units are connected with an optional system cable, a single-phase three-wire 4 kVA power system will be achieved.

The output voltage can be set via the phase voltage or line voltage.

Refer to Chapter 3 "Installation and Connection" first and carry out proper connection over two EPO 2000X.

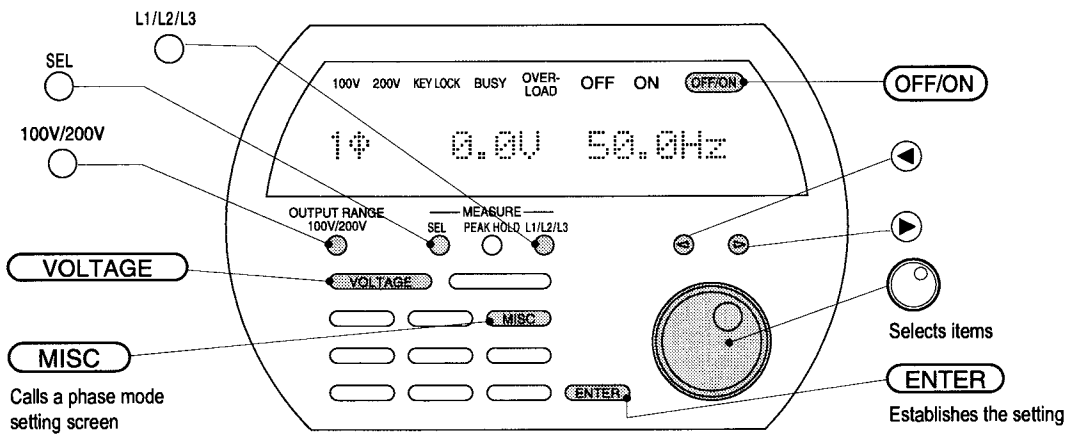

Turning ON/OFF the power

1 Turn ON the power switches on all EPO 2000X units.

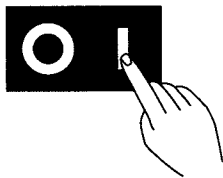

2 The system will be available as a single-phase three-wire 4 kVA power supply, with only the master unit being operable.

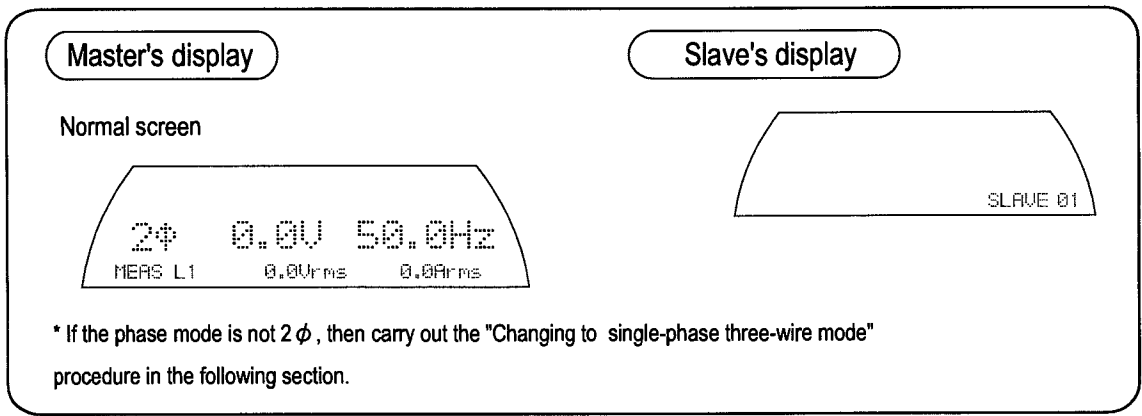

EPO 2000S/2000X

● 6. Use of Enhanced EPO 2000X System ●

- 3 To shut off the power input, turn off the power switch on each EPO 2000X unit.



Attention!

- Power switches may be turned on in any order. However, all switches must be turned on within 15 seconds to secure normal startup. If you failed in this, turn off all switches then turn them on again after several seconds.
- Power switches may be turned off in any order as well.



Memo

- Operation is performed only on the master's panel.
- On slave's panel, any operation will not be accepted.

Changing to single-phase three-wire mode

- 1 Press **MISC** couples of times until a phase setting screen appears.

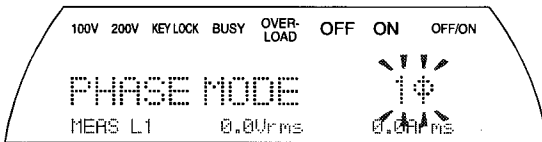

- 2 Turn the dial  and select 2 φ .

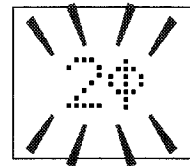

- 3 Press **ENTER** , and a message will prompt you: "Please RESTART"

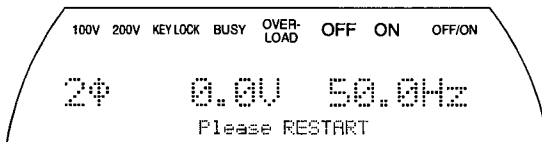

The indication denotes the phase mode of "single-phase", "single-phase three-wire" and "three-phase" as follows:

Indication	Phase mode
1 φ	Single-phase
2 φ	Single-phase three-wire
3 φ	Three-phase

At this moment, any button is not operable.

- 4 Turn off the power switches on all the EPO 2000X units.



- 5 When all indications have disappeared, turn on all power switches.

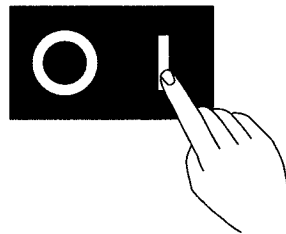

- 6 The system is started in single-phase three-wire mode afresh.

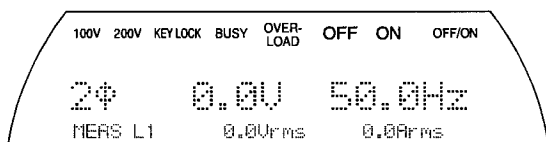

Attention!

When the power is turned on, the system starts up with the contents stored at Address 1 of the memory. Just after the change of phase mode, the phase mode field at Address 1 is rewritten with the newly selected phase mode. Store afresh the status of normal use into Address 1.

Exemplary voltage setting: supplying single-phase three-wire 200 V output

- 1 Press on the master unit to select the voltage range.

* To supply single-phase three-wire 200 V (line voltage of 200 V) output, select the 100 V range.

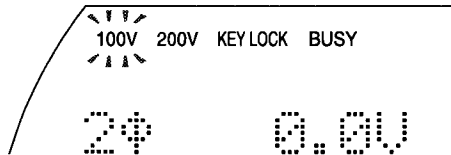

- 2 Repeat pressing **VOLTAGE** on the master unit, and the display toggles showing a "Phase voltage setting" and "Line voltage setting" screens while the voltage indication blinks.

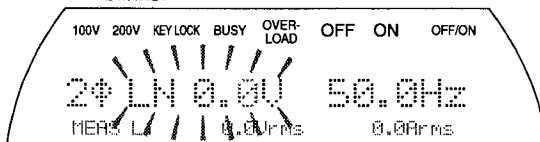

- 3 Press and to locate the cursor.

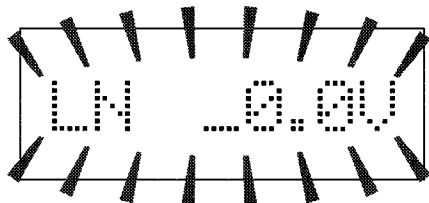

- 5 Press **OFF/ON** to turn on the output.

* Now the system is ready to provide single-phase three-wire power.



Attention!

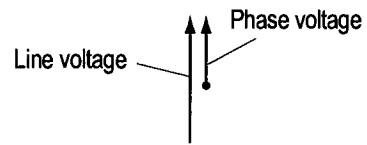

Voltage range	Maximum phase voltage	Maximum line voltage
100 V range	150.0V	300.0V
200 V range	300.0V	600.0V

Phase voltage setting

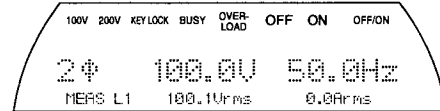

Line voltage setting

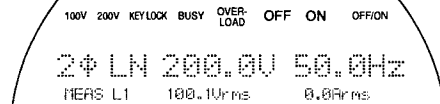

- 4 Turn the dial to select the desired output voltage.

* To supply single-phase three-wire 200 V output, select 100.0 V in phase voltage or 200.0 V in line voltage.

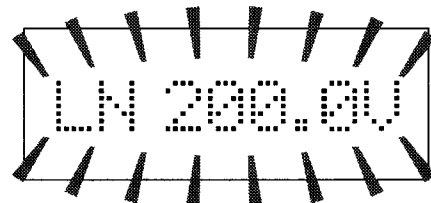

Memo

- If voltage setting is selected in line voltage, then the normal screen and the upper limit to output voltage are also shown in line voltage.
- Line-to-line voltage setting is made in 0.2 V resolution.



Memo

- If the user needs an AC power supply with 300 V or higher voltage, then configure a single-phase three-wire system. This can supply up to line 600 Vac power.

Using a measuring function in single-phase three-wire configuration

This function measures and displays "RMS value of voltage and current", "peak value of voltage and current", "apparent power", "effective power", and "power factor".

It is possible to change the phase of measurement.

1 Every press on SEL shows in turn different measurements in the bottom line as follows:

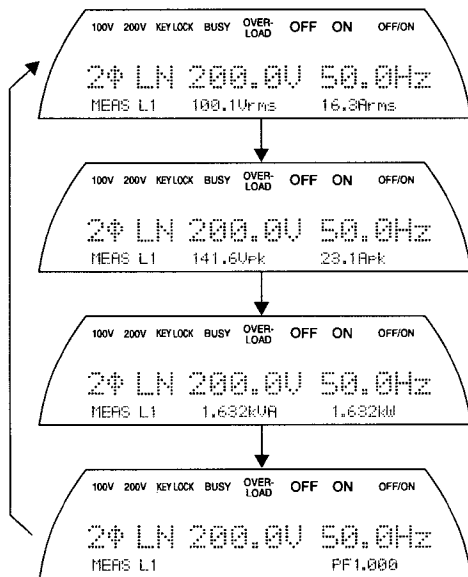

2 A press on L1/L2/L3 changes the phase of measurement.

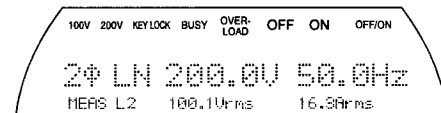

Different measurements are displayed one after another as shown below.

Measurement phase changes by press on <input type="radio"/> L1/L2/L3	Indication of measurements			
	Vrms, Arms	Vpk, Apk	kVA, kW	PF
L1	L1-phase voltage, L1-phase current		L1-phase apparent power L1-phase effective power	L1-phase power factor
L2	L2-phase voltage, L2-phase current		L2-phase apparent power L2-phase effective power	L2-phase power factor
L1-L2	L1-L2 line-to-line voltage, L1-phase current		Phase-total apparent power Phase-total effective power	All-phase power factor

Different functions in single-phase three-wire mode

Output limit setting	If the normal screen is shown in line-to-line voltage, the upper limit to output voltage is also indicated and can be set in line-to-line voltage.
DC output mode	Not available.
Storage function	Recall is not possible to the address at which different phase mode is stored.
Setting the power-on phase on output turn on	L1-phase power-on phase can be set.
Peak current retaining function	Measurement is available similarly to in single-phase mode. The phase of measurement can be changed as well.

Phase indication and phases

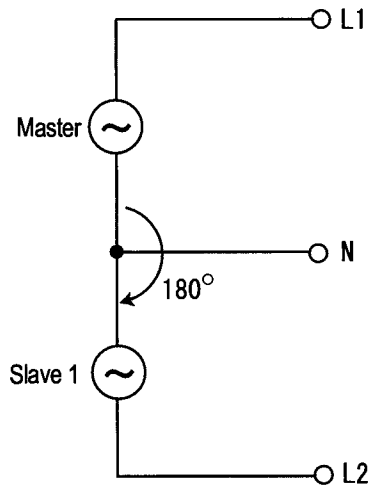



Reducing the system into a singular unit operation

- 1 Disconnect the optional system cable(s) and modify the output cable connection.

(👉 Refer to Chapter 3 "Installation and Connection")

- 2 Turn on the power switch.

• Now a singular unit operation is available.

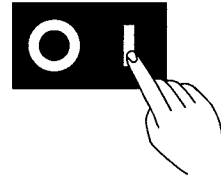

Attention!

- When the system cable connection is changed, the contents stored via master's storage function will be initialized.
- Contents in slave's memory remains unchanged.

7

Useful Functions

- versatile functions are ready for use -

■ In this chapter, I will show you how to use advantageous functions that EPO 2000S/EPO 2000X provides.

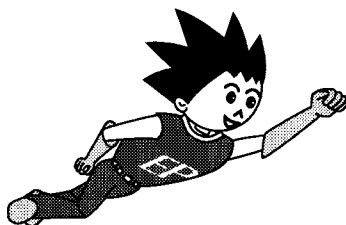

Using numeric keypad for setting

With the optional numeric keypad, the user can directly enter values to set the output voltage, output frequency and other setting items. In addition, memory can be recalled by a single touch on the keypad.

Caution!
 The numeric keypad must be connected prior to power charging. With the power being supplied, connection or disconnection of the numeric keypad may cause malfunction.

Connecting the numeric keypad

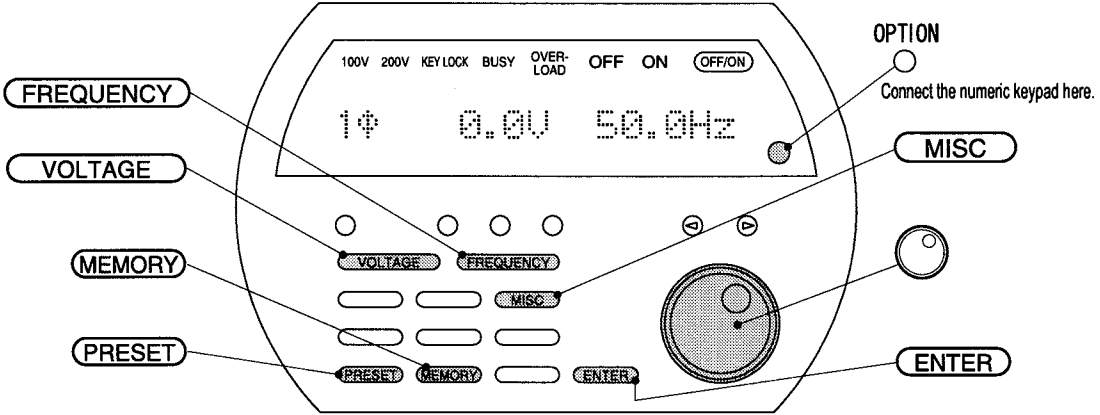
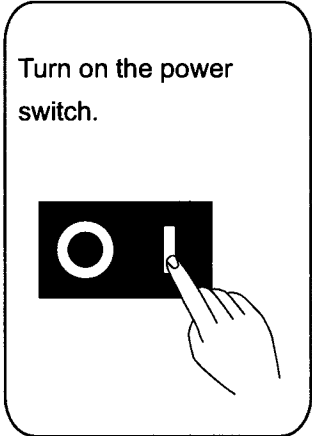
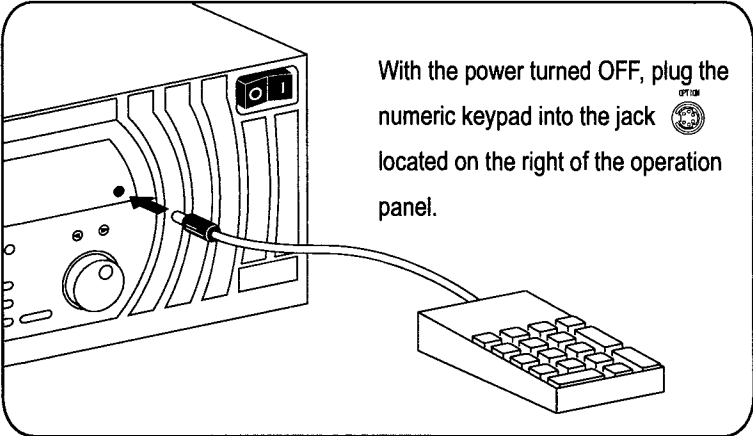

Selecting operation mode of numeric keypad

Select either of two operation modes of the numeric keypad.

The "10KEY" mode allows the user to directly entry the value of output voltage, output frequency and other items (this mode is selected on shipping).

The other "RECALL" mode can recall the contents stored in the memory by a single button touch on the numeric keypad. This mode is effective in sequential tests under preset conditions.

- 1 Press **MISC** couples of times until a numeric keypad operation setting screen appears.

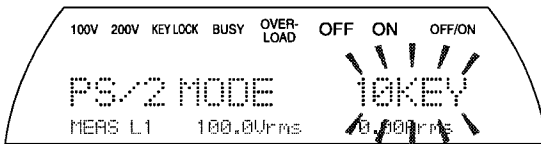

- 2 Turn the dial and select either of "10KEY" and "RECALL".

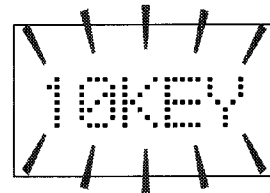

- 3 Press **ENTER** to establish the selection, and the display returns to the normal screen.

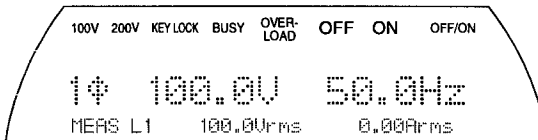

Memo

If "10KEY" is selected for operation mode, numeric entry is available for the following setting items:

- Output voltage (phase/line/DC)
- Output frequency
- Upper limit to output voltage (phase/line/DC)
- Upper limit to output frequency
- Lower limit to output frequency
- Storage memory number
- Recall memory number
- GPIB address

Operation in numeric entry (10KEY) mode

The following section describes operation by taking "output voltage" and "memory recall address" as example.

Setting the output voltage by numeric entry

- 1 Press **VOLTAGE** to show the output voltage setting screen.

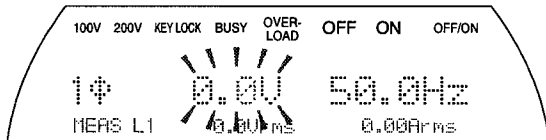

- 2 From the numeric keypad, enter the desired value for setting (values appears in the bottom line).

Example: To specify 100.1 V, enter on the keypad.

1 **0** **0** **.** **1** on the keypad.

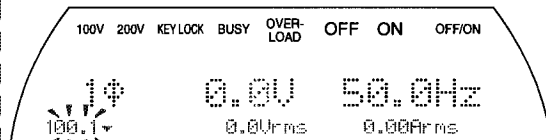

- 3 Press **ENTER** on the keypad to establish the entered value.

* Here, press **ENTER** on the keypad instead of that on the operation panel.

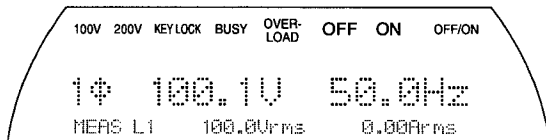

Attention!

Dissimilar to setting on rotary dial, just numeric entry does not establish the entered value.

Be sure to press **ENTER** on the numeric keypad at the end of entry.



Memo

If any wrong number is entered, press the slash **/** button. This cancels the last entered number and allows you to continue setting.



Memo

If you press **ENTER** on the operation panel during value setting on the numeric keypad, the numbers that have been entered so far will be discarded. The output voltage setting prior to starting this setting will become effective and the display returns to the normal screen.



Memo

Even if you attempt to set a value that is out of the setting range or a value that exceeds the upper limit to the output voltage, numeric entry is accepted. However, when you press **ENTER** on the keypad, the numbers that have been entered so far will be discarded and the display returns to the output voltage setting screen.

Setting memory recall address by numeric entry

- 1 Press **MEMORY** twice to show the memory recall setting screen.

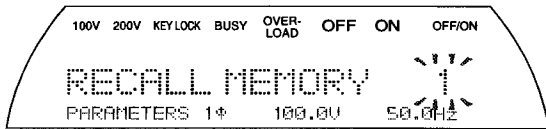

- 2 From the numeric keypad, enter the desired value for setting (values appears in the bottom line).

Example: To specify 2, enter

2 on the keypad.

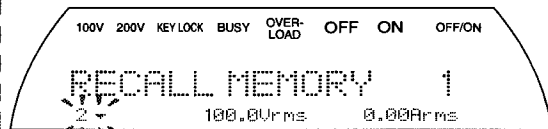

- 3 Press **ENTER**.

* You may press either **ENTER** on the operation panel or on the numeric keypad to establish the entered value.

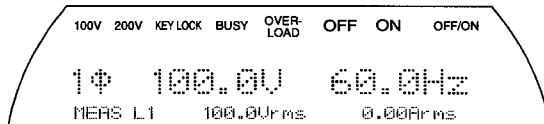

Memo

If any wrong number is entered, press the slash **/** button. This cancels the last entered number and allows you to continue setting.



Memo

If you press **ENTER** on the operation panel during value setting on the numeric keypad, this recalls the memory at the address of the numbers that have been entered so far and the display returns to the normal screen.



Memo

Even if you attempt to set a value that is out of the setting range numeric entry is accepted. However, when your press **ENTER** the keypad, the numbers that have been entered so far will be discarded and the display returns to the memory recall setting screen.

Operation in memory recall (RECALL) mode

Recalling the contents in memory by a single button touch on the numeric keypad

- 1 Press the desired memory address for recall.
Example: To recall memory 3, then enter .

This numeric keypad operation can recall memory at Addresses 0 to 9.

To recall memory address 10, press

PRESET.



Memo

You do not have to press **ENTER** to recall memory dissimilar to numeric entry of output voltage.

On the other hand, you cannot correct wrong entry of memory address on the keypad.



Memo

Similarly to memory call on the operation panel, some memory cannot be recalled depending on the conditions of AC/DC, phase mode (single-phase/single-phase three-wire/three-phase) and other factors.

For further information, refer to Chapter 5 "Versatile Use - for advanced users -".

Line synchronization

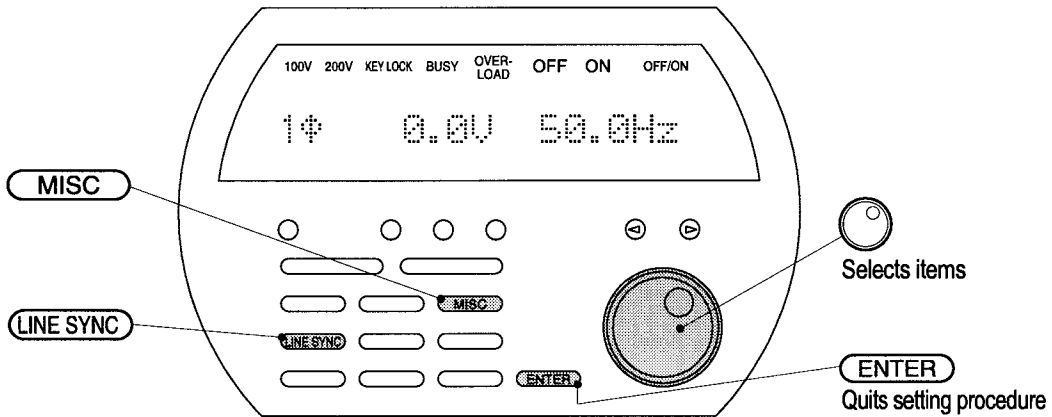

This function synchronizes the output frequency to the frequency of the AC power supply line. Synchronization is available to the power supply line in the range of 48 to 62 Hz frequency. It is possible to specify 50 Hz or 60 Hz for the reset frequency at the moment of disabling the line synchronization.

Enabling line synchronization

- 1 Press **LINE SYNC**, and the system enters a status of enabled line synchronization and a line synchronization screen appears.
-
- The screenshot shows the display with '100V 200V KEYLOCK BUSY OVER-LOAD OFF ON OFF/ON' at the top. The main display shows '1Φ', '100.00V', and 'LINE SYNC'. Below this, it shows 'MEAS L1 100.00Vrms 0.0Arms'.

Memo

* If line synchronization is switched between ON and OFF with the output supply being kept ON, the output will be turned OFF.

Disabling line synchronization

- 1 Press **LINE SYNC**, and the system quits the status of line synchronization and the display returns to the normal screen.
-
- The screenshot shows the display with '100V 200V KEYLOCK BUSY OVER-LOAD OFF ON OFF/ON' at the top. The main display shows '1Φ', '100.00V', and '50.0Hz'. Below this, it shows 'MEAS L1 100.00Vrms 0.0Arms'.

Setting the reset frequency at the line synchronization OFF moment

- 1 Press **MISC** couples of times until a screen for setting the reset frequency at the line synchronization OFF moment appears.

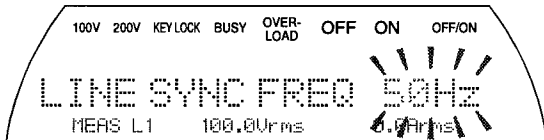

- 2 Turn the dial  and select the reset frequency at the line synchronization OFF moment.

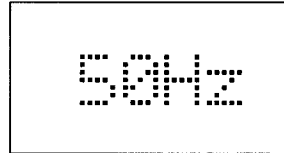

- 3 Press **ENTER** to quit the selection procedure, and the display returns to the normal screen.

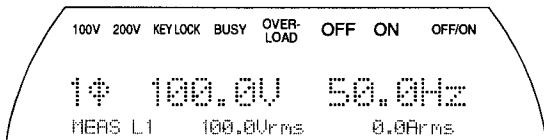

Frequency of 50 or 60 Hz is available for setting.



Attention!

If the frequency setting range defined by the setting of frequency limiting value(s) does not contain the range from 50 or 60 Hz, line synchronization cannot be enabled.

Switching ON/OFF beep warning

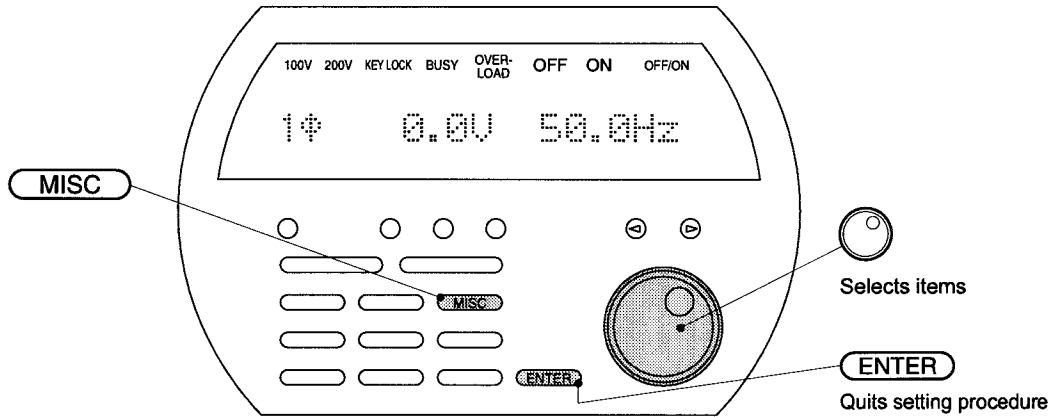

A beep is issued for warning if any impermissible setting is attempted or when the system suffers overload. This function can be disabled if the beep warning is not necessary.

Enabling/disabling beep warning

1 Press **MISC** couples of times until a beep warning setting screen appears.

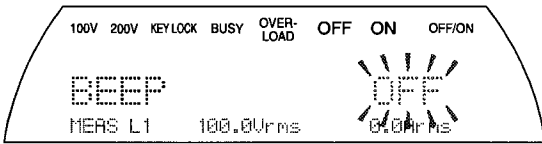

2 Turn the dial and select "ON" or "OFF".

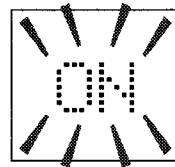

3 Press **ENTER** to quit the selection procedure, and the display returns to the normal screen.

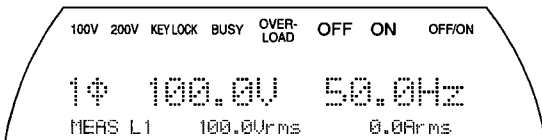

"ON" for enabling beep warning.
"OFF" for disabling beep warning.

Key lock

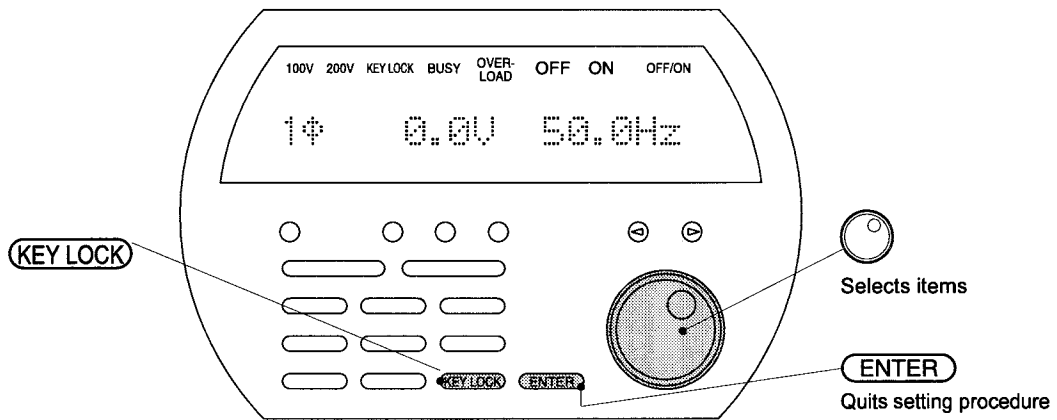

This function prevents settings from accidental modification caused by wrong operation.

Enabling key lock

1 Press **KEY LOCK** to show the key lock setting screen.

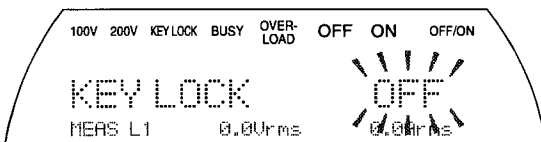

2 Turn the dial and select "ON".

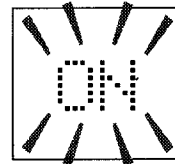

3 Press **ENTER** to quit the selection procedure, and the display returns to the normal screen.

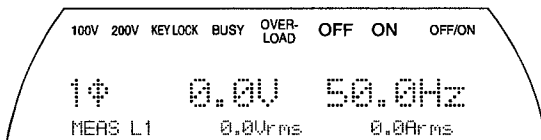

Disabling key lock

- 1 Press **KEY LOCK** to show the key lock setting screen.

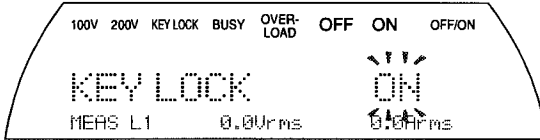

- 2 Turn the dial  and select "OFF".

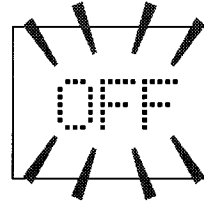

- 3 Press **ENTER** to quit the selection procedure, and the display returns to the normal screen.

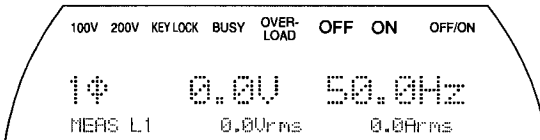

Attention!

When the key lock function is ON, the system accepts only the operation to disable the key lock (i.e., operation of **KEY LOCK** , **ENTER** and rotary dial).



Operation with 100 V input

EPO 2000S/EPO 2000X units can operate with a 100 V power input. However, the output capacity is limited to about 800 VA.

Power supply from 100 V wall outlet can energize the system for check of operation or can be used for contribution to stabilizing 100 Vac.



Attention!

Operation with nominal 100 V input means a power input voltage range of 85 to 132 V.



Attention!

Operation with nominal 100 V input limits the output capacity to about 800 VA. If the output exceeds this level, the system will limit the output, with the overload lamp lighting up.

8

GPIB Interface

■ In this chapter, we will discuss the GPIB interface. I will firstly explain about preparation and setting to those users who use programs. Secondly, I will give elucidation to those who create programs.



Outline of GPIB

P-STATION/EPO can control most of functions that are operated from the panel using GPIB.

If functions can be controlled by GPIB, then they can be controlled also by RS-232 except some other functions.

Actual operation or programming depends on the programming language on the controller side or the GPIB driver.

For further information, see their respective instruction manual and related documents together with this manual.

Functions that cannot be operated via GPIB

- Turning ON/OFF of power supply
- Initialization to on-shipping settings
- Switching between GPIB and RS-232
- Setting of GPIB address and message terminator on sending occasion
- Setting of baud rate, parity and character length of RS-232

Functions that can be controlled via the GPIB but cannot be operated from the panel

- GPIB proper functions (e.g., status byte, remote/local etc.)

Applicable specifications

- Conforming to IEEE standard 488.1-1987
- Interface functions (See the table below.)

SH1	Provides all functions of source handshake
AH1	Provides all functions of acceptor handshake
T6	Provides functions of basic talker, serial poll and listener-defined talker-releasing; does not provide talk-only function
L4	Provides functions of basic listener and listener-defined listener-releasing; does not provide listen-only function
SR1	Provides all functions of service request
RL1	Provides all functions of remote/local
PP0	Does not provide parallel poll function
DC1	Provides all functions of device clear
DT1	Provides all functions of device trigger
C0	Does not provide controller functions



Connection of GPIB cable

Connect a GPIB cable that meets the specifications to the GPIB bus line.

With a GPIB cable that meets the specifications, connect the GPIB bus lines. Before connection to the bus, turn off power to all devices connected. Securely tighten the connector fixing screws to prevent loosening.

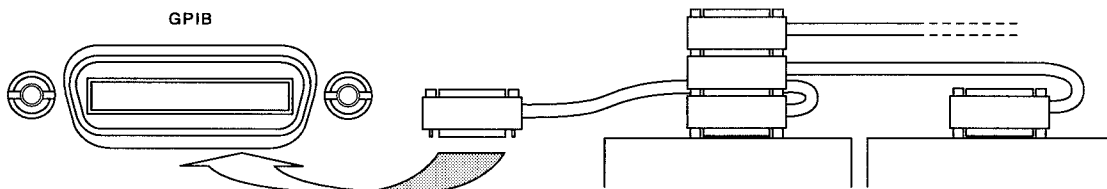

Connection of GPIB cable



Attention!

When two or three EPO2000X units are connected to enhance the system, connect the GPIB connector to the master.



Instructions on use of GPIB

When using GPIB, follow the general instructions listed below.

- Connection or disconnection of GPIB connector with the power supply turned on may damage the equipment. Turn off the power to all devices that are (to be) connected to the bus.
- To enable GPIB functions, turn on the power to all devices connected to the bus.
- Up to 15 devices can be connected to the bus including the controller.
- When determining the cable length, make sure it does not exceed the following length:

The length of a cable between devices must be 4m or less.

Total length of cables must be 2m multiplied by the number of devices or 20m whichever is shorter.

- Assign a different address to each device connected to a bus.

Assigning the same address to two or more devices may not only cause the devices to operate abnormally but also damage the devices.

- A terminator (delimiter of message) must be unified in a system.

If the terminator is different between the talker and the listener, the system may not function properly.

Setting for GPIB use

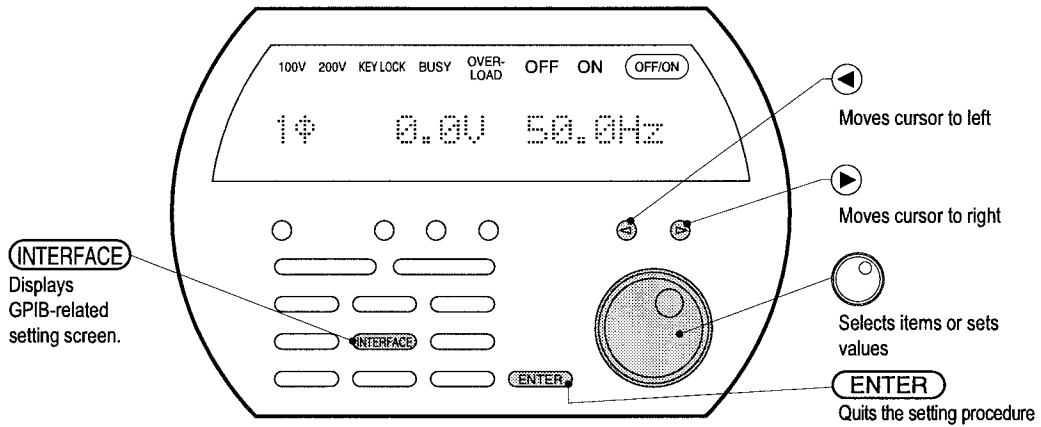

To use the GPIB interface, connect to the unit to the computer with the GPIB interface cable and carry out "Selection of interface", "Setting of GPIB address" and "Setting of terminator".

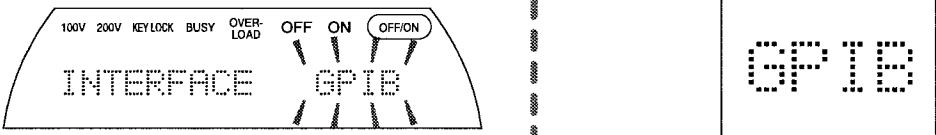

Selecting the interface

- Press **INTERFACE** to show the interface setting screen.
* "GPIB" is selected on shipping.
- Turn the dial  to select "GPIB".



The first screenshot shows the main display with 'INTERFACE' and 'GPIB' highlighted. The second screenshot shows the dial set to 'GPIB'.

Setting the GPIB address

- Press **INTERFACE** to show the GPIB address setting screen.
- Press  and  to locate the cursor.

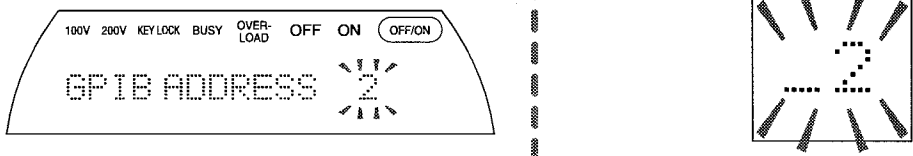

The first screenshot shows the display with 'GPIB ADDRESS' and a cursor on the digit '2'. The second screenshot shows a close-up of the dial with the cursor on the '2'.

3 Turn the dial  to specify the address.

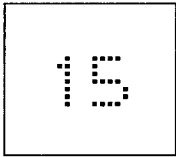

Select a desired one out of 0 to 30 addresses.
Number "2" is set on shipping.

Setting a terminator

1 Press **INTERFACE** to show the GPIB terminator setting screen.

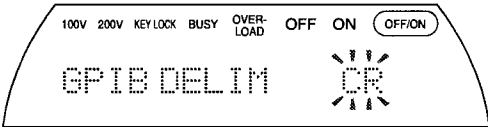

2 Turn the dial  to select the desired terminator.

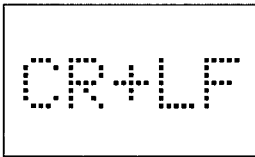

3 Press **INTERFACE** or **ENTER** to establish the selection and the display returns to the normal screen.

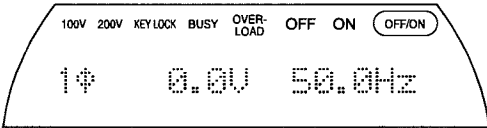

Select one out of terminators: CR+LF, CR and LF.

 **Attention!**

- GPIB and RS-232 cannot be used simultaneously. Select one interface to be used.
- GPIB is selected as the default interface (on-shipment setting).
- During a remote operation using GPIB, any keys other than **LOCAL** (local mode) and **OFF/ON** on the operation panel cannot be operated. **OFF/ON** can only be used when the output is OFF for an emergency stop.

Remote status and release from remote condition

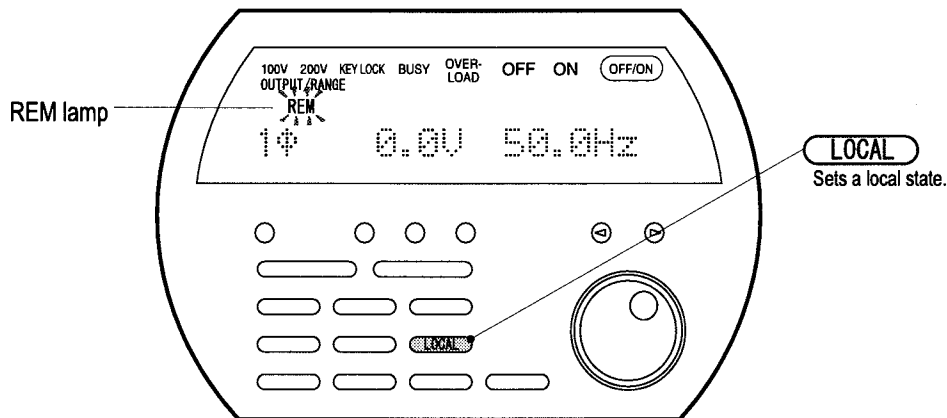

Remote state

With REN (Remote ENable) set to TRUE, sending a program message from the GPIB controller will put the unit in a remote state and cause the REM lamp on the panel to light up.

Local state

This unit remains in a local state until it receives control from the GPIB controller. All keys can be operated from the panel in the local state.

To set the unit in a local state from the GPIB controller, select either of the following two:

- Specify the GPIB address and send a GTL interface message.
- Set REN (Remote ENable) to FALSE.

Setting the system to "Local lockout"

It is also possible to operate **LOCAL** from the panel to set a local state, but the operation varies depending on whether "Local lockout" (LLO) is set or not.

- When LLO is not set.

In a remote state, only **LOCAL** on the panel is accepted and operating LOCAL puts the unit in a local state.

- When LLO is set.

In a remote state, no key operations from the panel are accepted.

To set LLO, send an LLO interface message in the remote state. To release LLO, set REN (Remote ENable) to FALSE.



Attention!

- The method of using interface messages varies depending on the GPIB controller (GPIB driver). See their respective instruction manuals.
- LLO is generally used when it is inconvenient to carry out operations from the panel during GPIB control, but if it is preferable to enable panel operations in the case of abnormalities, etc., it is recommendable not to use LLO.



Service request and status structure

Outline of status report

When various events occur, a GPIB device can generally send a service request (SRQ) to the controller for interrupt processing. The user can see the status at that moment by reading the contents of each register.

Status byte

A GPIB device has some pieces of status data and they are summarized in the status byte of the device.

Sending a service request

If a bit of the service request enable register is set to 1, then the system will send a service request (SRQ) when the corresponding status bit of the status byte becomes 1.

Capture of an event

The situation of a GPIB device is shown in the condition register and its change is recorded in the event register. If the corresponding bit of the event enable register is set to 1, each bit of the event register will be summarized in the specific one bit of the status byte.

Grasp of queue situation

A GPIB device has a queue to retain the information of output waiting. The status byte contains a status bit that indicates whether the queue has information or not.

P-STATION/EPO provides an MAV bit that indicates the queue situation of response message.



Memo

When a user wants to monitor the condition of a GPIB device, the user sometimes performs serial poll or sends a querying message. These methods, however, are not preferable because they apt to affects the operating speed of the controller (computer) and the GPIB device.

In such situations, the user can extend the interval of query or use a service request in order to enhance the performance.



Status byte register and sending a service request

A status byte register contains a summarized data of the situation of a GPIB device.

If a bit of a service request enable register is set to 1, then the system will send a service request (SRQ) when the corresponding status bit becomes 1.

The user can read the status byte by using either of the following two methods:

- Serial poll
- Query via a command “?STB” (the response message will be in a decimal integer.)

Reading a status byte register will not clear the bits (except that the RQS bit is reset when serial poll is performed).

Serial poll is a GPIB function in which the controller assigns an address to read the status byte of each GPIB device. The method of describing a program depends on the language on the controller side and the GPIB driver software.

In P-STATION/EP0, the service request enable register can execute setting and query using the following message:

- Setting: by a command “SRE” (the data to be set is in a decimal integer and initial value is “0”.)
- Query: by a command “?SRE” (the response data will be in a decimal integer.)

The data to be set and the response data are decimal integers with addition of the weight of the bit that was set to 1 of each register.

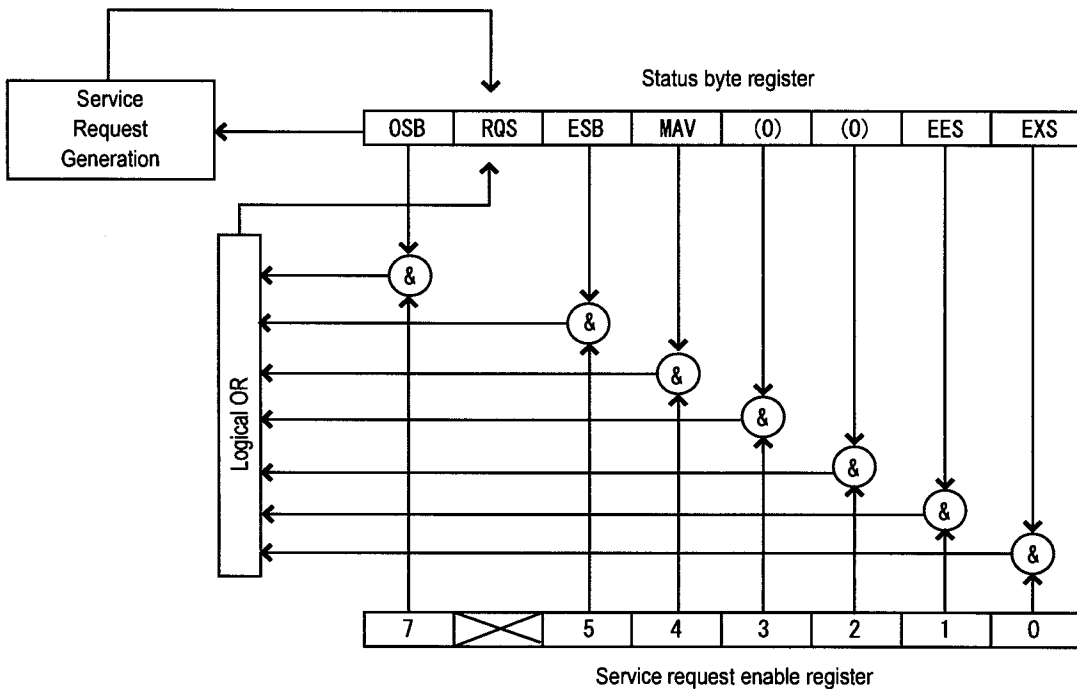

Bit	Weight	Description
OSB (7)	128	Operation event status register summary bit If any of the effective bits of the above register becomes 1, this will be set to 1, and if all of them become 0, then this will be cleared to 0.
RQS (6)	64	Request service bit If a service request takes place, this will be set to 1 and if serial poll is performed, this will be cleared to 0.
ESB (5)	32	Standard event status register summary bit If any of the effective bits of the above register becomes 1, this will be set to 1, and if all of them become 0, then this will be cleared to 0.
MAV (4)	16	Response message output enabled If, answering to the querying message, a response is written in the queue, enabling the output, this will be set to 1, and if the queue becomes empty, this will be cleared to 0.
3	8	Always 0 (not used)
2	4	Always 0 (not used)
EES (1)	2	Extended event register summary bit If any of the effective bits of the above register becomes 1, this will be set to 1, and if all of them become 0, then this will be cleared to 0.
EXS (0)	1	Extended status register summary bit If any of the effective bits of the above register becomes 1, this will be set to 1, and if all of them become 0, then this will be cleared to 0.

Detailed structure of status

The previous status prior to summarizing in a status byte register exists in several event registers. In every event register, exists a corresponding enable register, and summary into status byte can be permitted or prohibited by bits.

Further, the event register will not be cleared to 0 even if the status byte register is read by serial poll.

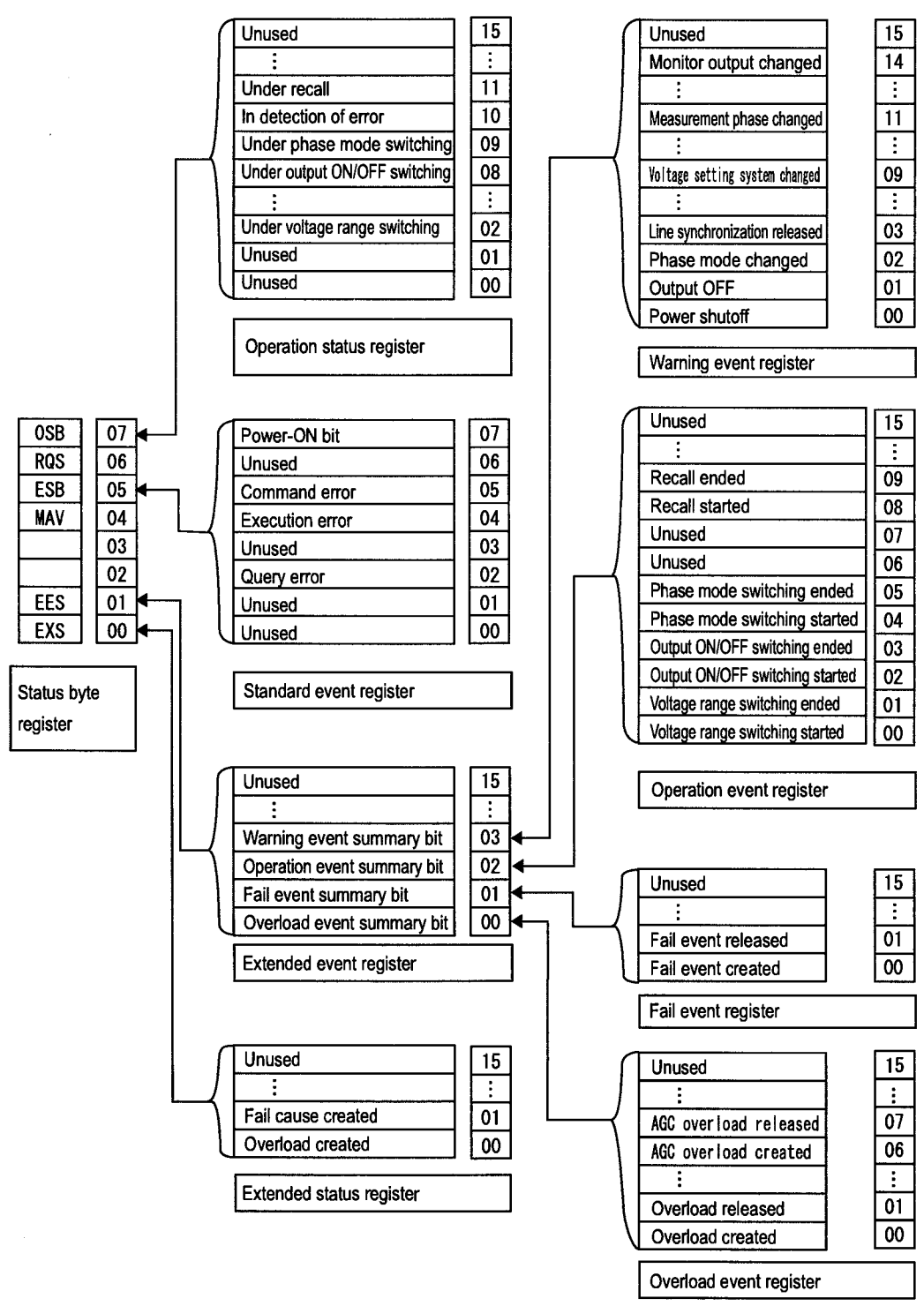

EPO 2000S/2000X

Standard event status register and related registers

The standard event status register is a register that is commonly given to every GPIB device that conforms to IEEE-488.2 standards. This register expresses the condition of a device. (See "Bit assignment of the standard event status register".)

A standard event status register can be queried with the following message:

- ?ESR (the response data will be in a decimal integer.)

Every bit of a standard event status register will be cleared to 0 when:

- A standard event status register is read.

Every bit of a standard event status register can be summarized into an ESB bit of the status byte register by setting the corresponding bit of the standard event status enable register to 1.

A standard event status enable register can be set or queried using the following messages where the data is the total of the weight of factors that are set to 1.

- Setting: ESE (the data to be set is in a decimal integer and initial value is "0".)
- Query: ?ESE (the response data will be in a decimal integer.)

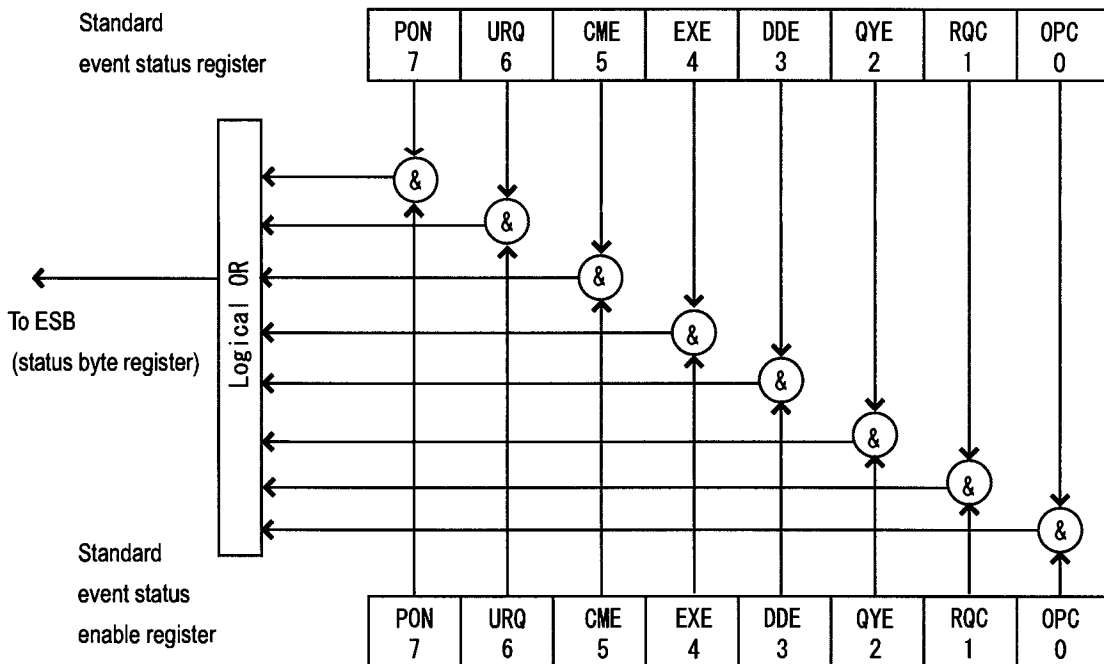

Bit assignment of standard event status register

Bit (weight)	Mnemonic	Description
7 (128)	PON	Power-ON This is set to 1 when power is charged. When it is read and cleared to 0, it remains 0 until the power is charged again.
6 (64)	URQ	User request Always 0 (not used)
5 (32)	CME	Message error This will be set to 1 if any syntax error is detected in the program message.
4 (16)	EXE	Execution error This will be set to 1 if the program data is out of the setting range or specified setting is not possible due to the current situation.
3 (8)	DDE	Device definitive (or proper) error Always 0 (not used)
2 (4)	QYE	Query error This will be set to 1 if any of the following occurs: <ul style="list-style-type: none"> • Reading is attempted when the queue contains no response message (RS-232 does not yield this error.) • Queue capacity limit (256 characters) is exceeded. • A next program message was received when sending of a response message to a query has not been completed.
1 (2)	RQC	Request for control authority Always 0 (not used)
0 (1)	OPC	Operation completed Always 0 (not used)

EPO 2000S/2000X

Operation status register and related registers

The operation status register is a register that indicates that internal processing is in progress. This register can be queried by the following message:

- ?OSC (the response data will be in a decimal integer.)

Every bit of the operation status register changes from 0 to 1 when its cause or operation starts and changes from 1 to 0 when its cause or operation ends.

Every bit of the operation status register is cleared to 0 when the following event occurs:

- Its cause corresponding to each bit or operation ends.

Every bit of the operation status register can be summarized into the OSB bit of the status byte register by setting the corresponding bit of an operation status enable register to 1.

An operation status enable register can be set or queried using the following messages where the data is the total of the weight of factors that are set to 1.

- Setting: OSE (the data to be set is in a decimal integer and initial value is "0".)
- Query: ?OSE (the response data will be in a decimal integer.)

Bit assignment of operation status register

Bit (weight)	Description
15	Always 0 (not used)
14	
13	
12	
11 (2048)	Under recall
10 (1024)	Under detection of fail cause Some causes may shut off the power to the power section in order to protect the system. This indicates some causes have been detected.
9 (512)	Under switching of phase mode
8 (256)	Under switching of output ON/OFF
7	Always 0 (not used)
6	
5	
4	
3	Under switching of output voltage range
2 (4)	
1	Always 0 (not used)
0	

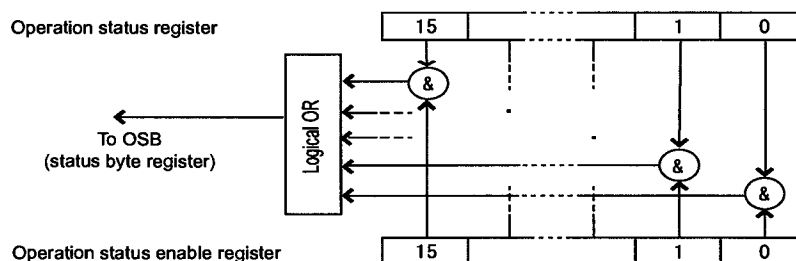

Extended event register and related registers

The extended event register is a register to organize contents of several event registers. This register can be queried by the following message:

- ?XEC (the response data will be in a decimal integer.)

When the logical sum of the warning event register, operation event register and fail event register changes from 0 to 1, the corresponding bit of the extended event register will be set to 1.

Every bit of the extended event register is cleared to 0 when any of the following occurs:

- When a warning event register is read (corresponding bit only).
- When an operation event register is read (corresponding bit only).
- When a fail event register is read (corresponding bit only).
- When an overload event register is read (corresponding bit only).
- When a message CLS (Clear Status related registers) is sent.

Every bit of an extended event register can be summarized into an EES bit of the status byte register by setting the corresponding bit of the extended event enable register to 1.

An extended event enable register can be set or queried using the following program messages where the data is the total of the weight of factors that are set to 1.

- Setting: XEE (the data to be set is in a decimal integer and initial value is "0".)
- Query: ?XEE (the response data will be in a decimal integer.)

Bit assignment of extended event register

Bit (weight)	Description
15	Always 0 (not used)
14	
⋮	
⋮	
4	
3(8)	Warning event register summary bit
2(4)	Operation event register summary bit
1(2)	Fail event register summary bit
0(1)	Overload event register summary bit

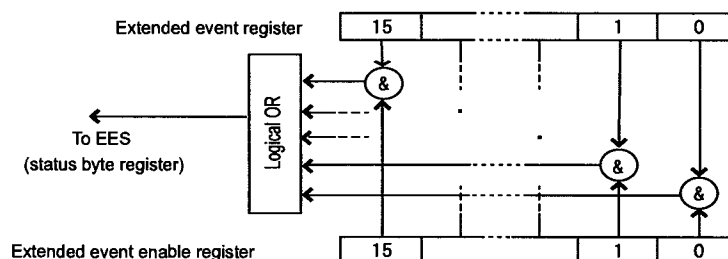

Warning event register and related registers

The warning event register is a register that indicates an especially important operating state of a device such as shutdown. This register can be queried by the following message:

- ?WSC (the response data will be in a decimal integer.)

Every bit of the warning register is cleared to 0 when either of the following events occurs:

- A warning event register is read
- A message CLS (Clear Status related registers) is sent

Every bit of the warning event register can be summarized into the corresponding bit (bit 03) of the extended event register by setting the corresponding bit of the warning event enable register to 1.

A warning event enable register can be set or queried using the following program messages where the data is the total of the weight of factors that are set to 1.

- Setting : WSE (the data to be set is in a decimal integer and initial value is "0".)
- Query : ?WSE (the response data will be in a decimal integer.)

Bit assignment of warning event register

Bit (weight)	Description
15	Always 0 (not used)
14(16384)	After switching phase mode, sets monitor output to initial value. *1
⋮	Always 0 (not used)
11(2048)	When switching phase mode, changes selection of measurement phase to L1 phase. *1
⋮	Always 0 (not used)
9(512)	When switching phase mode, sets AC voltage setting system to phase voltage. *1
⋮	Always 0 (not used)
3(8)	Line synchronization released
2(4)	Phase mode switched *1
1(2)	Output OFF Output is turned OFF for protection when an overload condition lasted for a long time or similar cases.
0(1)	Power supply to the power section is shut off for protective measure.

*1 In the case of EP02000S or EP02000X, always set to 0.

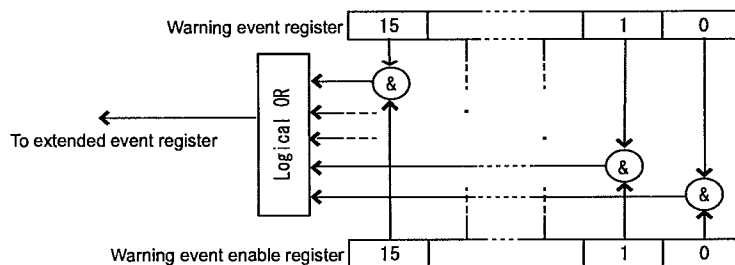

Operation event register and related register

The operation event register is a register to notify the start or end of processing of a cause whose internal processing time is relatively long. This register can be queried by the following message:

- ?OPC (the response data will be in a decimal integer.)

Every bit of the operation event register is cleared to 0 when either of the following events occurs:

- An operation event register is read
- A message CLS (Clear Status related registers) is sent

Every bit of the operation event register can be summarized into the corresponding bit (bit 02) of the extended event register by setting the corresponding bit of the operation event enable register to 1.

An operation event enable register can be set or queried using the following program messages where the data is the total of the weight of factors that are set to 1.

- Set t i n g : OPE (the data to be set is in a decimal integer and initial value is "0".)
- Query : ?OPE (the response data will be in a decimal integer.)

Bit assignment of operation event register

Bit (weight)	Description
15	Always 0 (not used)
14	
⋮	
11	
10	
9 (512)	Memory recall operation ended
8 (256)	Memory recall operation started
7	Always 0 (not used)
6	
5 (32)	Phase mode switching ended *1
4 (16)	Phase mode switching started *1
3 (8)	Output ON/OFF ended
2 (4)	Output ON/OFF started
1 (2)	Range switching ended
0 (1)	Range switching started

*1 In the case of EP02000S or EP02000X, always set to 0.

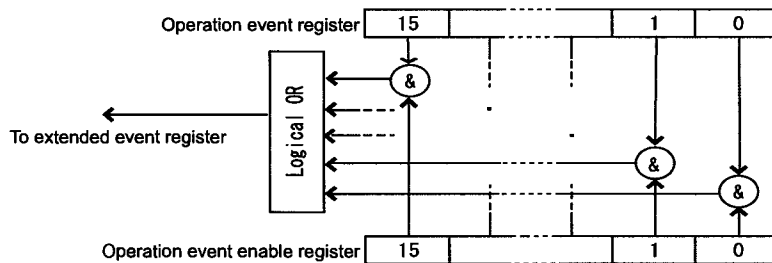

Fail event register and related registers

The fail event register is set when especially important problems (fail causes) are detected to protect the internal circuit. This register can be queried by the following message:

- ?FLC (the response data will be in a decimal integer.)

Every bit of the fail event register is cleared to 0 when either of the following events occurs:

- A fail event register is read
- A message CLS (Clear Status related registres) is sent

Every bit of the fail event register can be summarized into the corresponding bit (bit 01) of the extended event register by setting the corresponding bit of the fail event enable register to 1.

A fail event enable register can be set or queried using the following messages where the data is the total of the weight of factors that are set to 1.

- Setting : FLE (the data to be set is in a decimal integer and initial value is "0".)
- Query : ?FLE (the response data will be in a decimal integer.)

Bit assignment of fail event register

Bit (weight)	Description
15	Always 0 (not used)
14	
⋮	
⋮	
2	
1(2)	Recovery from fail (shutoff of power supply to the power section) cause
0(1)	Detection of fail (shutoff of power supply to the power section) cause

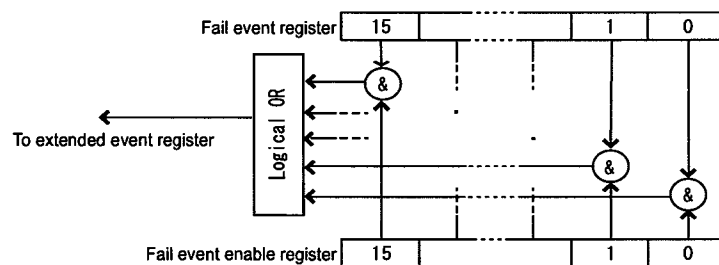

Overload event register and related registers

The overload event register is a register that reflects the output overload situation. This register can be queried by the following message:

- ?OVC (the response data will be in a decimal integer.)

Every bit of the overload event register is cleared to 0 when either of the following events occurs:

- An overload event register is read
- A message CLS (Clear Status related registers) is sent

Every bit of the overload event register can be summarized into the corresponding bit (bit 00) of the extended event register by setting the corresponding bit of the overload event enable register to 1.

An overload event enable register can be set or queried using the following program messages where the data is the total of the weight of factors that are set to 1.

- Setting : OVE (the data to be set is in a decimal integer and initial value is "0".)
- Query : ?OVE (the response data will be in a decimal integer.)

Bit assignment of overload event register

Bit (weight)	Description
15	Always 0 (not used)
⋮	
7 (128)	Release from AGC overload condition. Remote sensing AGC changed the condition of the unit from outside the correction range to within the correction range.
⋮	
6 (64)	Occurrence of AGC overload condition Remote sensing AGC put the unit outside the correction range.
⋮	
⋮	Always 0 (not used)
1 (2)	Releases from overload condition
0 (1)	Occurrence of overload condition

* Remote sensing AGC is not available in the EP02000X or EP02000S.

Related bits are always set to 0.

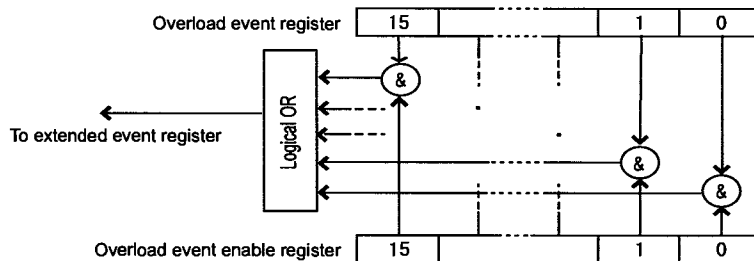

Extended status register and related registers

The extended status register is provided with bits indicating fail causes or overload condition. This register can be queried by the following message:

- ?XSC (the response data will be in a decimal integer.)

Every bit of the extended status register changes from 0 to 1 when its cause or operation begins and changes from 1 to 0 when its cause or operation ends.

Every bit of an extended status register is cleared to 0 when the following event occurs:

- The cause corresponding to each bit or operation ends.

Every bit of an extended status register can be summarized into the EXS bit of the status byte register by setting the corresponding bit of the extended status enable register to 1.

An extended status enable register can be set or queried using the following messages where the data is the total of the weight of factors that are set to 1.

- Setting : XSE (the data to be set is in a decimal integer and initial value is "0".)
- Query : ?XSE (the response data will be in a decimal integer.)

Bit assignment of extended status register

Bit (weight)	Description
15	Always 0 (not used)
14	
⋮	
⋮	
2	
1(2)	A fail (shutoff of power supply to the power section) cause being produced
0(1)	An overload being produced

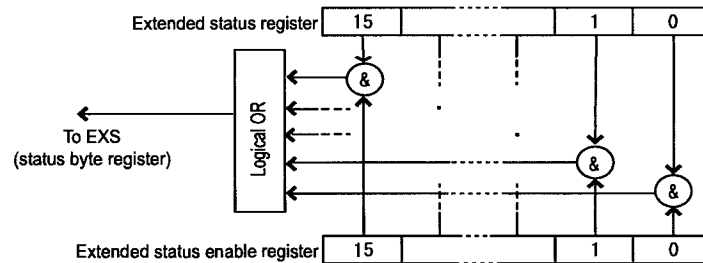



Program messages

A program message is tentatively stored in the input buffer. When a terminator is received, the message is interpreted and executed in the FIFO order. The input buffer has a capacity of 256 characters (i.e., 256 bytes) and nulls (00H) and terminators are not accepted in the input buffer.

When interpretation and execution are completed, the input buffer is emptied to admit the next coming data.

If a program message that exceeds 256 characters is sent, only valid part of the message included in the first 256 characters is executed, then an error occurs.

A program message consists of a header and a parameter. Messages can be sent successively if each of them does not exceed the character capacity of the input buffer. The format of a program message is shown below.

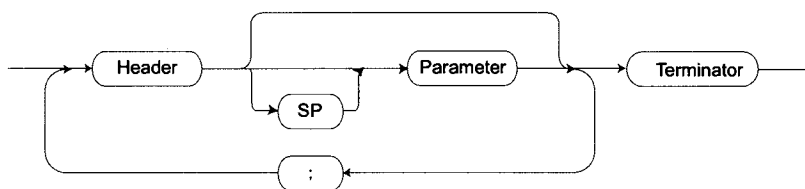

To send two or more program messages at a time, a semicolon ";" must be inserted between the program messages.

Program messages are broadly classified into two categories of "setting messages" that execute setting or operation directive and "querying messages" that query status or settings.

Program message basic form

A basic format of setting message is shown below. This example sets frequency to 50 Hz and output voltage to 100Vrms.

(Example of setting message) Sets frequency to 50 Hz and output voltage to 100Vrms.

$$\frac{\text{FRQ}}{a} \frac{50}{b} \frac{}{c} \frac{}{d} ; \frac{\text{VLT}}{a} \frac{100}{b} \frac{}{c}$$

(Example of query message) Query of voltage measured value or current measured value

$$\frac{?MVR}{a} \frac{}{b} \frac{}{d} ; \frac{}{b} \frac{?MCR}{a}$$

a: This is called a header. Both upper and lower case alphabets are available and even mixture of them may be used. A query message is headed by "?".

b: This is a space to improve legibility. Any number of spaces or a null space may be used.

c: Parameter section. This begins with a sign (+ or -), number, or a decimal point. When a sign is omitted, control recognizes it as a positive value.

d: This is a semicolon (or a message terminator) to divide two or more setting messages.

Setting messages

Data form in setting message

The following two parameter data forms are available:

- NR1 form

This is an integer type. A virtual decimal point is deemed to be placed at the end of the digits.

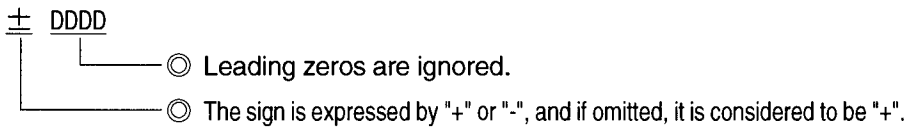

Examples : +01234
-50001
18

- NR2 form

This is a real number type. A decimal point is expressed with a period ".". Digits in the decimal places may be omitted, and omitted digits are taken to be all "0". An exponential form can also be used.

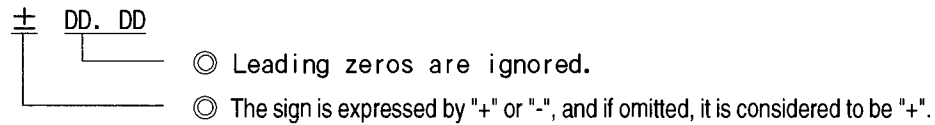

Examples : +0.1234
-50.001
1.8
1.00E+2
200

Querying message

This is a program message to query the status of selection, setting and other items. This is always headed by a question mark "?".

If "talker" is specified after sending a querying message, the response to it will be output.

When two or more queries are made at a time, two or more responses will be output each divided with a semicolon ";". A response character string exceeding 255 characters in total will produce an error and no response is returned. If a query is made without specifying the talker (receiving a response) and a further query(ies) is made, then up to five responses will be stored. However, other excessive data will be deleted from the oldest response.

Output format for response is shown below.



It is possible to set ON/OFF of the header included in response data by a setting message of "HDR 1" or "HDR 0". When power is turned on, the header is set to ON (to output the header).

Form of response data to a querying message

The following three types of response parameter data forms are available:

- NR1 form

This is an integer type.

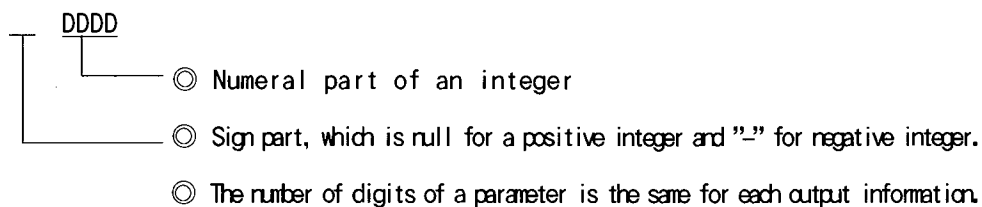

Example : RNG 1

This indicates that the output voltage range is set to the 200 V range.

- NR2 form

This is a real number type.

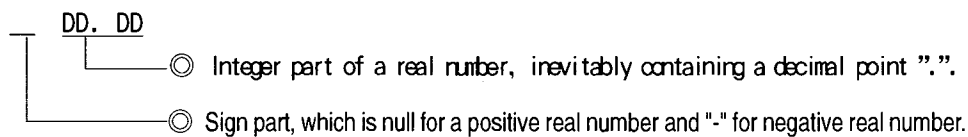

Example : FRQ 50.0

This indicates that the output frequency is set to 50.0 Hz.

- STRING form

This is character string data using ASCII (ISO 7-bit) codes



Situation in which no message is accepted (BUSY)

In general, a computer serving as the GPIB controller, etc. is expected to be free from the constraints by specific processing and able to perform various kinds of processing simultaneously.

When a GPIB device under the control of the GPIB controller spends a long time for its internal processing, if it stops communication (handshake) by attaching greater importance to message exchange processing, the GPIB device can no longer perform other processing in the meantime, resulting in reduced throughput on the GPIB controller side.

From this standpoint, when a specific message is sent from the GPIB controller, P-STATION/EP0 continues to perform handshake as it is and stores the message in the internal buffer temporarily, but does not interpret or execute it, which results in an execution error. Such a situation is called "BUSY".

Duration of BUSY varies depending on the processing content, but is at least approximately 700ms.

BUSY is indicated by a BUSY lamp on the panel and it is possible to recognize BUSY by referencing the status related register from the GPIB controller.

To continue setting after sending a BUSY-related message, refer to the contents of these registers in the program and be careful not to send messages during BUSY.

BUSY related messages

Header	Function	BUSY duration	Caution
OUT	Output ON/OFF switching	Approx. 700ms	During overload, etc., the output may be forcibly turned OFF for internal protection and BUSY occurs in this case.
RNG	Selection of output voltage range	Approx. 700ms	The output voltage range can be set for AC and DC separately. When AC/DC switching is performed, if the voltage range changes before and after the switching, a range switching may occur producing BUSY.
DCM	AC/DC output switching	Approx. 700ms	
PMD	Phase mode switching	Max. approx. 2s	BUSY duration varies depending on phase mode state before and after switching and system capacity.
RCL	Memory recall	Approx. 700ms	A change to any one of the settings above before and after a recall may produce BUSY.

To recognize BUSY state from controller

It is possible to recognize the start and end of the BUSY state by referencing the operation event register. Likewise, it is possible to know whether BUSY is in place or not by referencing the operation status register.



Attention!

Also see a processing example included in the sample program.



List of program messages

Commands are used in common when GPIB and RS-232 interfaces are used.

However, the function indicated by a header "STB" would be ineffective if the RS-232 interface is used.

In addition, a space " " can be inserted between the header and the parameter of a command in order to improve the legibility.

Setting of output voltage and output range

Header	Function	Parameter	Data Form		Default
			Setting	Query	
RNG	To select AC output voltage range	0 : 100 V range 1 : 200 V range	NR1	NR1	100 V range
	To select DC output voltage range	0 : 100 V range 1 : 200 V range	NR1	NR1	100 V range
VLT	To set AC output phase voltage	0.0 to 300.0 Unit: [Vrms] Resolution: 0.1 [Vrms]	NR2	NR2	0.0 [Vrms]
	To set AC output line-to-line voltage (three-phase)	0.0 to 519.6 Unit: [Vrms] Resolution: 0.2 [Vrms]	NR2	NR2	0.0 [Vrms]
	To set AC output line voltage (single-phase three-wire)	0.0 to 600.0 Unit: [Vrms] Resolution: 0.2 [Vrms]	NR2	NR2	0.0 [Vrms]
	To set DC output voltage	0.0 to 424.0 Unit: [Vdc] Resolution: 0.1 [Vdc]	NR2	NR2	0.0 [Vdc]
VMD	To select AC output voltage setting method	0: phase voltage setting method 1: line-to-line voltage setting method	NR1	NR1	Phase voltage setting method

RNG: Range

VLT: Voltage

VMD: Voltage Mode

Example : To set the output voltage range to 100 V range and output voltage to 100 Vrms.

Setting of output voltage range to 100 V range RNG 0

Setting of output voltage to 100 Vrms VLT 100.0



Attention!

- With the output voltage range set to 100 V, a setting that exceeds the following value will cause an error:
 150 Vrms in AC mode 212 Vrms in DC mode
 In the above case, select 200 V for the output voltage range. In addition, if the set voltage sent from the voltage setting is higher than the voltage limit level, an error will be caused. If this is the case, check the voltage limit value.
- When the system is switching the output voltage range, any command will not be interpreted. If a subsequent command is sent at this moment, this will also cause an error. Confirm that the range has been switched by the status byte before sending a subsequent command.

Setting of output frequency

Header	Function	Parameter	Data Form		Default
			Setting	Query	
FRQ	To set an output frequency	5.0~550.0 Unit: [Hz] Resolution: 0.1 [Hz]	NR2	NR2	50.0 [Hz]

FRQ : Frequency

Example : To set an output frequency to 60 Hz.

To set output frequency to 60.0 Hz FRQ 60.0

Switching ON/OFF the output

Header	Function	Parameter	Data Form		Default
			Setting	Query	
OUT	To switch ON/OFF the output	0: Output OFF 1: Output ON	NR1	NR1	Output OFF

OUT:Output

Example : To set ON/OFF of output

To set the output to ON OUT 1

To set the output to OFF OUT 0

Measuring function

Header	Function	Parameter	Data Form		Default
			Setting	Query	
MVR	To query result of RMS AC voltage measurement		None	NR2	None
	To query result of DC voltage measurement		None	NR2	None
MVP	To query result of peak AC voltage measurement		None	NR2	None
MCR	To query result of RMS AC current measurement		None	NR2	None
	To query result of DC current measurement		None	NR2	None
MCP	To query result of peak AC current measurement		None	NR2	None
	To query result of peak hold		None	NR2	None
MWT	To query result of effective power measurement		None	NR2	None
MVA	To query result of apparent power measurement		None	NR2	None
MPF	To query result of power factor measurement		None	NR2	None
MSL	To select measurement parameter indication	0: RMS voltage, current 1: Peak voltage, current 2: Effective, apparent power 3: Power factor	NR1	NR1	RMS voltage, current
CPH	To change ON/OFF of current peak hold measurement	0: OFF 1: ON	NR1	NR1	OFF
MPH	To select phase of measurement	0: L1 phase 1: L2 phase 2: L3 phase 3: L1-L2 line-to-line 4: L2-L3 line-to-line 5: L3-L1 line-to-line	NR1	NR1	L1 phase

MVR:Measurement Voltage RMS

MVP:Measurement Voltage Peak

MCR:Measurement Current RMS

MCP:Measurement Current Peak

MWT:Measurement Wattage

MVA:Measurement VA

MPF:Measurement Power_Factor

MSL:Current Select

CPH:Current Peak Hold

MPH:Measurement Phase



Attention!

- To a query of measurement, returned will be the measurement for the phase that was selected for measurement, or the line-to-line measurement.
- The response data when queried with a message "MCP" varies depending on the setting state of the message "CPH" (current peak hold measurement ON/OFF).
When CPH 0 (peak hold OFF) has been selected: Result of peak AC current measurement
When CPH 1 (peak hold ON) has been selected: Result of peak hold measurement

Setting limit values

The user may put a limit(s) to the setting range of the output voltage and output frequency.

Header	Function	Parameter	Data Form		Default
			Setting	Query	
VUP	To set an upper limit to AC output phase voltage	0.0 to 300.0 Unit: [Vrms] Resolution: 0.1 [Vrms]	NR2	NR2	300. 0 [Vrms]
	To set an upper limit to DC output voltage	0.0 to 424.0 Unit: [Vdc] Resolution: 0.1 [Vdc]	NR2	NR2	424. 0 [Vdc]
	To set an upper limit to AC output line-to-line voltage (three-phase)	0.0 to 519.6 Unit: [Vrms] Resolution: 0.2 [Vrms]	NR2	NR2	519. 6 [Vrms]
	To set an upper limit to AC output line voltage (single-phase three-wire)	0.0 to 600.0 Unit: [Vrms] Resolution: 0.2 [Vrms]	NR2	NR2	600. 0 [Vrms]
FUP	To set an upper limit to output frequency	5.0 to 550.0 Unit: [Hz] Resolution: 0.1 [Hz]	NR2	NR2	550. 0 [Hz]
FLW	To set a lower limit to output frequency	5.0 to 550.0 Unit: [Hz] Resolution: 0.1 [Hz]	NR2	NR2	5. 0 [Hz]

VUP:Voltage Upper limit

FUP:Frequency Upper limit

FLW:Frequency Lower limit

Example : To limit the output voltage to 220 V at the maximum, and limit the frequency to 65 Hz at the maximum.

To set the output voltage upper limit to 220 V VUP 220.0

To set the output frequency upper limit to 65 Hz FUP 65.00



Attention!

- An error will be caused if the user attempts to set a value lower than the already set output voltage in the course of upper voltage limit setting procedure.
- An error will be caused if the user attempts to set a value lower than the already set output frequency in the course of upper frequency limit setting procedure. Also, an error will be caused if the user attempts to set a value lower than the already set lower frequency limit.
- An error will be caused if the user attempts to set a value higher than the already set output frequency in the course of lower frequency limit setting procedure. Also, an error will be caused if the user attempts to set a value higher than the already set upper frequency limit.
- An upper limit to the output in a three-phase system and in a single-phase three-wire system will be effective to the phase voltage of all phases.

Setting a Power-ON phase

The user may set the Power-ON phase on output turn-on moment.

Header	Function	Parameter	Data Form		Default
			Setting	Query	
SPH	To set a Power-ON phase	0: 0[deg] 1: 90[deg] 2: 180[deg] 3: 270[deg]	NR1	NR1	0[deg]

SPH:Start Phase

Precision mode and high stability mode setting

This function sets the condition of the output compensation.

The user can select the precision mode to minimize the fluctuation of output voltage against the change of load current. On the contrary, the user can select the high stability mode to maintain good stability against the capacitive load although the fluctuation of output voltage is a little higher.

Header	Function	Parameter	Data Form		Default
			Setting	Query	
PRC	To switch the mode between precision and high stability	0: High stability 1: Precision	NR1	NR1	Precision

PRC:Precision

Example: To set the status of output compensation to high stability.

To set the mode to high stability

PRC 0

Line synchronization

The user can synchronize the output frequency to the frequency of the commercial input power line to which the P-STATION/EPO is connected. The user can also set the frequency for the time of disabling the synchronization function.

Header	Function	Parameter	Data Form		Default
			Setting	Query	
LSY	To switch ON/OFF of line synchronization	0 : Line synchronization OFF 1 : Line synchronization ON	NR1	NR1	Line synchronization OFF
LSF	To set the frequency for line synchronization OFF moment	0 : 50[Hz] 1 : 60[Hz]	NR1	NR1	50[Hz]

LSY:Line Sync

LSF:Line Sync off Frequency

AC/DC selection

Header	Function	Parameter	Data Form		Default
			Setting	Query	
DCM	To switch AC/DC output	0: AC output 1: DC output	NR1	NR1	AC output

DCM:Direct Current Mode



Attention!

Setting of AC/DC selection will be accepted only when single-phase has been set in the phase mode. When single-phase three-wire or three-phase has been set in the phase mode, this attempt will result in an error.

Phase mode

Header	Function	Parameter	Data Form		Default
			Setting	Query	
PMD	To switch phase mode	0: Single-phase 1: Single-phase three-wire 2: Three-phase	NR1	NR1	Single-phase

PMD:Phase Mode



Attention!

- This setting will be accepted when AC has been set in AC/DC selection. When DC has been set in AC/DC selection, this attempt will result in an error.
- This message is invalid in the EP02000S or EP02000X.

Beep

Header	Function	Parameter	Data Form		Default
			Setting	Query	
BEE	To switch ON/OFF of beep	0: OFF 1: ON	NR1	NR1	ON

BEE:Beep

Remote sensing AGC

Header	Function	Parameter	Data Form		Initial value
			Setting	Query	
AGC	Remote sensing AGC ON/OFF switching	0: OFF 1: ON	NR1	NR1	OFF

Monitor output

Header	Function	Parameter	Data Form		Initial value
			Setting	Query	
M01	Setting of monitor output CH1 output source	0: L1-phase voltage 1: L1-phase voltage x1 2: L1-phase voltage x10 3: L2-phase voltage 4: L2-phase voltage x1 5: L2-phase voltage x10 6: L3-phase voltage 7: L3-phase voltage x1 8: L3-phase voltage x10	NR1	NR1	L1-phase voltage
M02	Setting of monitor output CH2 output source	0: L1-phase voltage 1: L1-phase voltage x1 2: L1-phase voltage x10 3: L2-phase voltage 4: L2-phase voltage x1 5: L2-phase voltage x10 6: L3-phase voltage 7: L3-phase voltage x1 8: L3-phase voltage x10			L1-phase voltage x1



Attention!

Messages related to the remote sensing AGC and monitor output are invalid in the EP02000S or EP02000X.

Memory

The user can store and recall set values and statuses in the battery-backup memory incorporated in the unit. Eleven memory addresses from 0 to 10 are provided.

Header	Function	Parameter	Data Form		Default
			Setting	Query	
STO	To store data	1~10	NR1	None	None
RCL	To recall data	0~10	NR1	None	None

STO:Store

RCL:Recall

Example: To store the current setting in memory address 2 and recall the data in memory address 2.

To store the current setting in memory address 2 STO 2

To recall the data in memory address 2 RCL 2

CAUTION

Once a setting by a message from GPIB is stored in memory, the setting stored in memory will not be changed even when operation is performed from the panel. Therefore, unexpected operation may occur when it is recalled.

If the user wants to change from interface control to manual operation, it is recommended to execute "Recall of Address 0" in order to return the memory to the initial status before doing so.



Attention!

In the EPO2000S or EPO2000X if system cable connection is altered, settings stored in the master unit's memory will be erased, and all data in every memory address will turn into the same initial setting values as that at address 0.



Attention!

- Memory address 0 contains default values, and it permits only recalling access. In addition, these default values cannot be modified. Memory address 1 is read on every occasion of power charging to the unit. Thus the user can store the normally used settings at this address so that the user will not have to set them every time at the beginning of operation.
- The GPIB address and other interface parameters are not the subject of memory store/recall function.
- Also some other settings are not the subject of memory store/recall function.

Hardware structure

Header	Function	Parameter	Data Form		Default																										
			Setting	Query																											
IDX	To query the model name	"P-STATION/EPO"	None	String	None																										
VER	To query the ROM version number	"1.00"	None	String	None																										
OPR	To query the hardware structure status	0~32767	None	NR1	None																										
<p>D15 - D14 Unused (always 0)</p> <p>D13 - D08 System capacity (Note 2)</p> <table border="1" style="margin-left: 20px; border-collapse: collapse; text-align: center;"> <thead> <tr> <th>Capacity</th> <th>Value</th> </tr> </thead> <tbody> <tr> <td>2kVA</td> <td>1</td> </tr> <tr> <td>4kVA</td> <td>2</td> </tr> <tr> <td>?</td> <td>?</td> </tr> <tr> <td>36kVA</td> <td>18</td> </tr> </tbody> </table> <p>D07 - D06 Unused (always 0)</p> <p>D05 Monitor output option (Note 1)</p> <table border="1" style="margin-left: 20px; border-collapse: collapse; text-align: center;"> <tbody> <tr> <td>0</td> <td>Yes</td> </tr> <tr> <td>1</td> <td>No</td> </tr> </tbody> </table> <p>D04 Remote sensing AGC option (Note 1)</p> <table border="1" style="margin-left: 20px; border-collapse: collapse; text-align: center;"> <tbody> <tr> <td>0</td> <td>Yes</td> </tr> <tr> <td>1</td> <td>No</td> </tr> </tbody> </table> <p>D03 Phase system type (Note 2)</p> <table border="1" style="margin-left: 20px; border-collapse: collapse; text-align: center;"> <tbody> <tr> <td>0</td> <td>Single-phase system</td> </tr> <tr> <td>1</td> <td>Multi-phase system</td> </tr> </tbody> </table> <p>D02 EPO2000 type</p> <table border="1" style="margin-left: 20px; border-collapse: collapse; text-align: center;"> <tbody> <tr> <td>0</td> <td>EPO 2000S</td> </tr> <tr> <td>1</td> <td>EPO 2000X</td> </tr> </tbody> </table> <p>D01 - D00 Unused (always 0)</p>						Capacity	Value	2kVA	1	4kVA	2	?	?	36kVA	18	0	Yes	1	No	0	Yes	1	No	0	Single-phase system	1	Multi-phase system	0	EPO 2000S	1	EPO 2000X
Capacity	Value																														
2kVA	1																														
4kVA	2																														
?	?																														
36kVA	18																														
0	Yes																														
1	No																														
0	Yes																														
1	No																														
0	Single-phase system																														
1	Multi-phase system																														
0	EPO 2000S																														
1	EPO 2000X																														

IDX : ID code X

VER : Version

OPR : Operation

(Note1) Always 0 in the case of EPO2000s / EPO2000X.

(Note2) The correspondence between a product model name and response data is shown below.

Capacity	D15	~	D13	D12	D11	D10	D09	D08	~	D03	D02	~	
EPO36000M	These bits are irrelevant to the product model name.		0	1	0	0	1	0	These bits are irrelevant to the product model name.	1	0	D00 - D01 are always 0.	
EPO24000M			0	0	1	0	1	0		1	0		
EPO18000M			0	0	1	0	0	1		1	0		
EPO12000M			0	0	0	1	1	0		1	0		
EPO6000M			0	0	0	0	1	1		1	0		
EPO12000S			0	0	0	1	1	0		0	0		
EPO10000S			0	0	0	1	0	1		0	0		
EPO6000S			0	0	0	0	1	1		0	0		
EPO4000S			0	0	0	0	1	0		0	0		
EPO2000S			0	0	0	0	0	1		0	0		
EPO2000X		(1 unit)	0	0	0	0	0	1		1	1		1
		(2 units)	0	0	0	0	1	0		0	1		1
	(3 units)	0	0	0	0	1	1	1	1	1			

Interface and Status related

Header	Function	Parameter	Data Form		Default
			Setting	Query	
HDR	To select header ON/OFF	0: Header OFF 1: Header ON	NR1	NR1	Header ON
CLS	To clear status-related registers Specify 0 for the following register: <ul style="list-style-type: none"> • Standard event register • Warning event register • Operation event register • Fail event register • Overload event register 	None	Only header	None	None
STB	Status byte register	Query	None	NR1	None
SRE		Enable register setting/query	0~255	NR1	0
ESR	Standard event status register	Query	Same as above		
ESE		Enable register setting/query			
OSC	Operation status register	Query	None	NR1	None
OSE		Enable register setting/query	0~32767	NR1	0
XEC	Extended event register	Query	Same as above		
XEE		Enable register setting/query			
WSC	Warning event register	Query	Same as above		
WSE		Enable register setting/query			
OPC	Operation event register	Query	Same as above		
OPE		Enable register setting/query			
FLC	Fail event register	Query	Same as above		
FLE		Enable register setting/query			
OVC	Overload event register	Query	Same as above		
OVE		Enable register setting/query			
XSC	Extended status register	Query	Same as above		
XSE		Enable register setting/query			

- Each status/event register is provided with an enable register, which can enable/disable a detection cause bit by bit.
- The enable register can not only set but also read a status. However, each status/event register can, by nature, only read a state by a query.

For details of the register-related messages, see "Detailed structure of status".



Response to interface message

Responses to interface message sent from the GPIB controller are listed below.

IFC	< Interface Clear > Initializes GPIB interface. Releases specified listener and talker.
DCL SDC	< Device Clear > < Selected Device Clear > Clears the input buffer and aborts interpretation and execution of command. Clears the input buffer and also clear bit 4 (MAV) of the status byte register. Releases SRQ sending.
LLO	< Local Lockout > Disables operation of the <input type="button" value="LOCAL"/> button in the operation section.
GTL	< Go To Local > Puts the unit in a local status.

Usage of interface messages varies with the GPIB driver on the controller side.

For details, refer to the manual for the GPIB driver.



Sample GPIB program

Outline of sample program

The following section introduces samples of remote control that uses GPIB interface.

Here, the following two cases are shown:

- Case where Microsoft's Visual Basic and Keithley's (Keithley Instruments Inc.) GPIB interface board are used
- Case where Visual Basic and National Instruments' GPIB interface board are used

The following two programs are presented for explanation.

a) Setting

This is a simplest program of initialization followed by setting of arbitrary voltage and frequency, then turning on the output.

b) Use of Query and SRQ

This program uses SRQ to detect range selection and turn-on/off operation while conducting the setting of arbitrary voltage and frequency.

In both examples, parameter range check etc. are omitted. When the user prepares a practical program, take into consideration error processing and initialization procedure.

In addition, these sample programs are prepared assuming a situation in which the unit is energized in the on-shipping condition. Note that the program may not operate properly in other conditions.

These sample programs can be downloaded from our homepage:

<http://www.nfcorp.co.jp/>

Case where Visual Basic and Keithley's GPIB interface board are used

When receiving (entering) a response message using Keithley's GPIB interface board and driver software, the length of the reception buffer character string variable is changed appropriately. The maximum number of characters to be received and the number of characters actually received are set by parameters different from those of the buffer.

a) Setting -KI

If the button of range or output is pressed, the system changes its status and displays the set status.

The values entered in the text box of frequency and voltage will be set when the setting button of each item is pressed.

Necessary initialization is executed by load of form.

Here, the device descriptor (Dev) is opened with the timeout of 200ms, GPIB address 2, E01 valid and terminator LF.

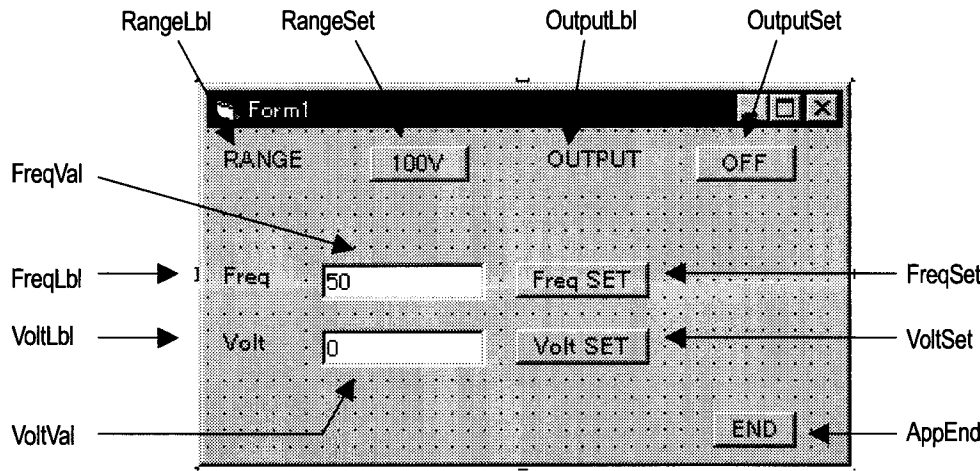

```

Option Explicit
Const Adr As Integer = 2
Dim Rng As Boolean
Dim Out As Boolean

Private Sub AppEnd_Click()
    Dim stat As Integer
    transmit "UNL LSTEN" & CStr(Adr) & "GTL", stat 'Go To Local
    End
End Sub

Private Sub Form_Load()
    Dim stat As Integer

    initialize 0, 0           ' Open the device
    settimeout (300)        ' Set time out
    transmit "DCL", stat    ' Clear the device

    Rng = False
    Out = False
End Sub
    
```

EPO 2000S/2000X

● 8. GPIB Interface ●

```

Private Sub FreqSet_Click()
    Dim stat As Integer
    send ADR, "FRQ" & FreqVal.Text, stat ' Set the frequency
End Sub

Private Sub OutputSet_Click()
    Dim stat As Integer
    If Out = False Then
        send ADR, "OUT 1", stat ' Set the output to ON
        OutputSet.Caption = "ON"
        Out = True
    Else
        send ADR, "OUT 0", stat ' Set the output to OFF
        OutputSet.Caption = "OFF"
        Out = False
    End If
End Sub

Private Sub RangeSet_Click()
    Dim stat As Integer
    If Rng = False Then
        send ADR, "RNG 1", stat ' Set the range to 200V
        RangeSet.Caption = "200V"
        Rng = True
    Else
        send ADR, "RNG 0", stat ' Set the range to 100V
        RangeSet.Caption = "100V"
        Rng = False
    End If
End Sub

Private Sub VoltSet_Click()
    Dim stat As Integer
    send ADR, "VLT" & VoltVal.Text, stat ' Set the voltage
End Sub

```



b) Use of Query and SRQ -KI

This operation is similar to that of the above sample a) except that the control detects that the system enters a BUSY condition on the point of range selection and output ON/OFF switching and queries related status and then temporarily disables command sending.

In the case of Keithley's GPIB driver, use the method by polling monitoring using a timer.

Polling can query the content of the event register or status register every time, but serial poll can reduce the load of the firmware of the device more than polling. To shorten polling intervals, use of serial poll is recommended.

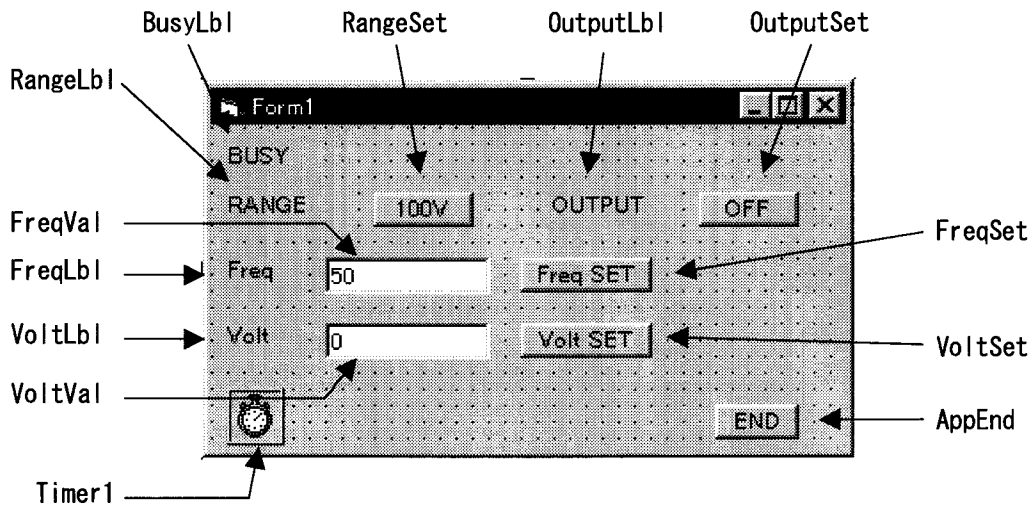
Note that before and after the serial poll routine spoll of Keithley's GPIB driver, universal commands SPE and SPD are required.



```
Option Explicit
Const Adr As Integer = 2
Dim Rng As Boolean
Dim Out As Boolean
```

```
Private Sub AppEnd_Click()
    Dim stat As Integer
    transmit "UNL LSTEN" & CStr(Adr) & "GTL", stat ' Go To Local
    End
End Sub
```

```
Private Sub Form_Load()
    Dim stat As Integer
    Dim rdbuf As String
    Dim l As Integer
    initialize 0, 0 ' Open the device
    settimeout (300) ' Set time out
    transmit "DCL", stat ' Clear the device
    send Adr, "SRE 2;XEE 14;OPE 15", stat ' Set the SRQ enable register
    send Adr, "?OPC", stat
    enter rdbuf, 256, l, Adr, stat
    send Adr, "?stb", stat
    enter rdbuf, 256, l, Adr, stat
    Rng = False
    Out = False
    BusyLbl.Enabled = False
    Timer1.Enabled = False
    Timer1.Interval = 500
End Sub
```

```

Private Sub FreqSet_Click()
    Dim stat As Integer
    send ADR, "FRQ" & FreqVal.Text, stat ' Set the frequency
End Sub

Private Sub OutputSet_Click()
    Dim stat As Integer
    If Out = False Then
        send ADR, "OUT 1", stat ' Set the output to ON
        OutputSet.Caption = "ON"
        Out = True
    Else
        send ADR, "OUT 0", stat ' Set the output to OFF
        OutputSet.Caption = "OFF"
        Out = False
    End If
    Timer1.Enabled = True ' Because RQS occurs on occasion of output setting
End Sub

Private Sub RangeSet_Click()
    Dim stat As Integer
    If Rng = False Then
        send ADR, "RNG 1", stat ' Set the range to 200V
        RangeSet.Caption = "200V"
        Rng = True
    Else
        send ADR, "RNG 0", stat ' Set the range to 100V
        RangeSet.Caption = "100V"
        Rng = False
    End If
    Timer1.Enabled = True ' Because RQS occurs on occasion of range selection
End Sub

Private Sub Timer1_Timer()
    Dim stat As Integer
    Dim stb As Integer
    Dim rdbuf As String
    Dim l As Integer
    Dim opc As Integer
    transmit "SPE", stat ' Required in KI board
    spoll ADR, stb, stat ' Serial poll
    transmit "SPD", stat ' Required in KI board
    If stb And 64 Then ' RQS cause check
        If stb And 2 Then
            send ADR, "?OPC", stat
            enter rdbuf, 256, l, ADR, stat
            opc = CInt(Right(rdbuf, 1))
            If (opc And 1) Or (opc And 4) Then
                BusyLbl.Enabled = True
                RangeSet.Enabled = False
                OutputSet.Enabled = False
                FreqSet.Enabled = False
                VoltSet.Enabled = False
            Else
                BusyLbl.Enabled = False
                RangeSet.Enabled = True
                OutputSet.Enabled = True
                FreqSet.Enabled = True
                VoltSet.Enabled = True
                Timer1.Enabled = False
            End If
            If (Out = True) And (opc = 9) Then
                OutputSet.Caption = "OFF"
                Out = False
            End If
        End If
    End If
End Sub

Private Sub VoltSet_Click()
    Dim stat As Integer
    send ADR, "VLT" & VoltVal.Text, stat 'Set the voltage
End Sub

```

Case where Visual Basic and National Instruments' GPIB interface board are used

When using National Instruments' GPIB interface board and driver software, a EOS character needs to be added to a character string to be sent.

Moreover, when receiving a response message (ibrd), the number of characters to be received is limited to the capacity of the reception buffer. The sample program presented here uses fixed-length character strings. If the user wants to use variable-length character strings, it is necessary to secure the capacity of the reception buffer using space(), etc. in front of ibrd. The number of received characters can be obtained by means of the global variable ibrct.

a) Setting -NI

If the button of range or output is pressed, the system changes its status and displays the set status.

The values entered in the text box of frequency and voltage will be set when the setting button of each item is pressed.

Necessary initialization is executed by load of form.

Here, the device descriptor (Dev) is opened with the timeout of 200ms, GPIB address 2, E01 valid and terminator LF.

Pressing the [END] button reinstates the system into a local status and closes the program

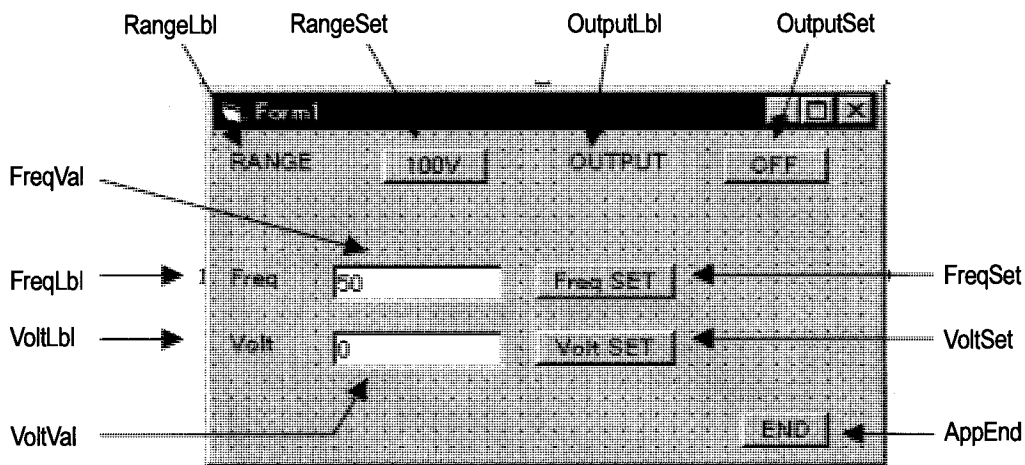

```
Option Explicit
Const Adr As Integer = 2
Const EOSCHAR As Integer = &HA
Const EOS As Integer = XEOS + REOS + EOSCHAR
Dim Dev As Integer
Dim Rng As Boolean
Dim Out As Boolean
```

```
Private Sub AppEnd_Click()
    Dim v As Integer
    v = 0
    ibloc Dev
    ibonl Dev, v
End Sub
End Sub
```

```
Private Sub Form_Load()
```

```

    ibdev 0, Adr, 0, T300ms, 1, EOS, Dev 'Open the device
    ibclr Dev 'Clear the device

    Rng = False
    Out = False
End Sub

Private Sub FreqSet_Click()
    ibwrt Dev, "FRQ" & FreqVal.Text & Chr(EOSCHAR) 'Set the frequency
End Sub

Private Sub OutputSet_Click()
    If Out = False Then
        ibwrt Dev, "OUT 1" & Chr(EOSCHAR) 'Set the output to ON
        OutputSet.Caption = "ON"
        Out = True
    Else
        ibwrt Dev, "OUT 0" & Chr(EOSCHAR) 'Set the output to OFF
        OutputSet.Caption = "OFF"
        Out = False
    End If
End Sub

Private Sub RangeSet_Click()
    If Rng = False Then
        ibwrt Dev, "RNG 1" & Chr(EOSCHAR) 'Set the range to 200V
        RangeSet.Caption = "200V"
        Rng = True
    Else
        ibwrt Dev, "RNG 0" & Chr(EOSCHAR) 'Set the range to 100V
        RangeSet.Caption = "100V"
        Rng = False
    End If
End Sub

Private Sub VoltSet_Click()
    ibwrt Dev, "VLT" & VoltVal.Text & Chr(EOSCHAR) 'Set the voltage
End Sub

```

b) Use of Query and SRQ -NI

This operation is similar to that of the above sample a) except that the control detects that the system enters a BUSY condition on the point of range selection and output ON/OFF switching and queries related status and then temporarily disables command sending.

To monitor SRQ and generate an event, use the GPIBNotify control. The GPIBNotify control is made available by selecting "gpiBNotify OLE Control Module" from "Component" in the "Project" menu of Visual Basic.

Event procedure (SRQNotify_Notify), which is started by SRQ, detects the BUSY condition by querying the serial poll and operation event register.

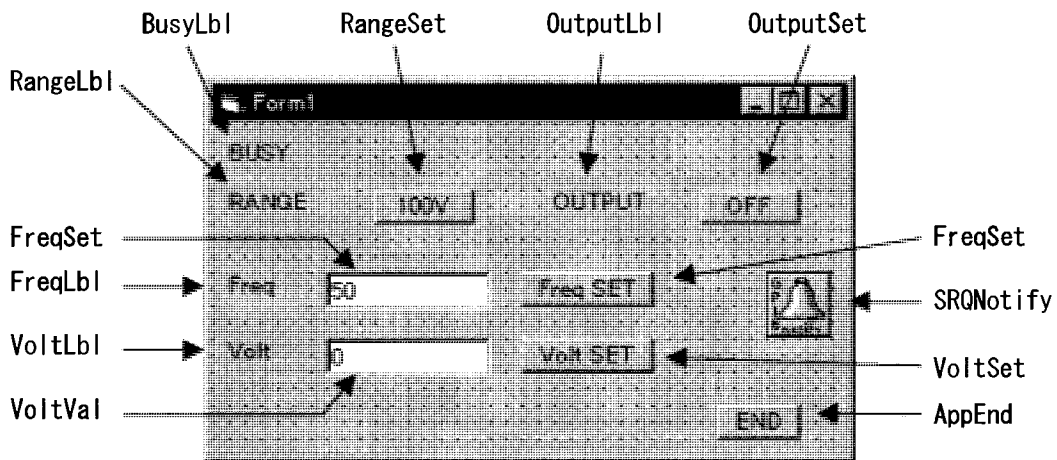

```

Option Explicit
Const ADR As Integer = 2
Const EOSCHAR As Integer = &HA
Const eos As Integer = XEOS + REOS + EOSCHAR
Dim Dev As Integer
Dim Rng As Boolean
Dim Out As Boolean

Private Sub AppEnd_Click()
    Dim v As Integer
    v = 0
    ibloc Dev
    ibonl Dev, v
End
End Sub

Private Sub Form_Load()
    Dim x As Long, y As Long
    Dim stat As Integer
    Dim rdbuf As String * 10

    ibdev 0, ADR, 0, T300ms, 1, eos, Dev 'Open the device
    ibclr Dev 'Clear the device

    ibwrt Dev, "SRE 2" & Chr(EOSCHAR)
    ibwrt Dev, "XEE 14" & Chr(EOSCHAR)
    ibwrt Dev, "OPE 15" & Chr(EOSCHAR)

```

```

    ibwrt Dev, "?OPC" & Chr(EOSCHAR)
    ibrd Dev, rdbuf
    ibwrt Dev, "?STB" & Chr(EOSCHAR)
    ibrd Dev, rdbuf
    stat = SRQNotify.SetupNotify(Dev, RQS)
    Rng = False
    Out = False
    BusyLbl.Enabled = False
End Sub

Private Sub FreqSet_Click()
    ibwrt Dev, "FRQ" & FreqVal.Text & Chr(EOSCHAR) 'Set the frequency
End Sub

Private Sub SRQNotify_Notify(ByVal LocalUd As Long, ByVal LocalIbsta As Long, ByVal
LocalIberr As Long, ByVal LocalIbcntI As Long, RearmMask As Long)
    Dim stb As Integer
    Dim opc As Integer
    Dim rdbuf As String * 10
    If (LocalIbsta And RQS) Then
        ibrsp Dev, stb
        If (stb And 2) Then
            ibwrt Dev, "?OPC" & Chr(EOSCHAR)
            ibrd Dev, rdbuf
            opc = CInt(Right(rdbuf, 6))
            If (opc And 1) Or (opc And 4) Then
                BusyLbl.Enabled = True
                RangeSet.Enabled = False
                OutputSet.Enabled = False
                FreqSet.Enabled = False
                VoltSet.Enabled = False
            Else
                BusyLbl.Enabled = False
                RangeSet.Enabled = True
                OutputSet.Enabled = True
                FreqSet.Enabled = True
                VlotSet.Enabled = True
            End If
        End If
        If (Out = True) And (opc = 9) Then
            OutputSet.Caption = "OFF"
            Out = False
        End If
        RearmMask = RQS
    End If
End Sub

Private Sub OutputSet_Click()
    If Out = False Then
        ibwrt Dev, "OUT 1" & Chr(EOSCHAR) 'Set the output to ON
        OutputSet.Caption = "ON"
        Out = True
    Else
        ibwrt Dev, "OUT 0" & Chr(EOSCHAR) 'Set the output to OFF
        OutputSet.Caption = "OFF"
        Out = False
    End If
End Sub

Private Sub RangeSet_Click()
    If Rng = False Then
        ibwrt Dev, "RNG 1" & Chr(EOSCHAR) 'Set the range to 200V
        RangeSet.Caption = "200V"
        Rng = True
    Else
        ibwrt Dev, "RNG 0" & Chr(EOSCHAR) 'Set the range to 100V
        RangeSet.Caption = "100V"
        Rng = False
    End If
End Sub

Private Sub VoltSet_Click()
    ibwrt Dev, "VLT" & VoltVal.Text & Chr(EOSCHAR) 'Set the voltage
End Sub

```

9

RS-232 Interface

■ This chapter describes RS-232 interface. I will first explain those who uses programs about preparation and setting. Then I will explain how to create a program.

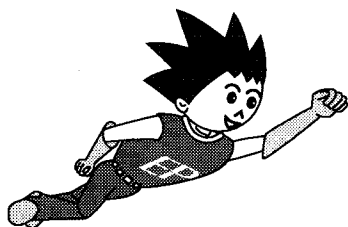



Outline of RS-232

With RS-232 interface, the system can perform external control similarly to the case of GPIB except for GPIB proper functions. It can perform setting and query using the same program messages as GPIB. Response messages to queries have the same format as that for GPIB.

Since much overlapping is found between the two, the same contents as those for GPIB are omitted here. When the user is to use RS-232 for external control, also refer to materials for GPIB.

a) Functions that GPIB does have but RS-232 does not (GPIB proper functions)

- Selection of remote/local
- Interrupt to controller by means of service request and serial pole
The user can read status using a querying message (?STB) etc.
- GPIB proper command such as "Device Clear"
- Connection of multiple devices

RS-232 supports only one-to-one connection.

b) Specifications

- Baud rate : 1200, 2400, 4800, and 9600
- Length of data bit: 7, 8
- Length of stop bit: 1, 2
- Parity: none, even, odd

Settings for using RS-232

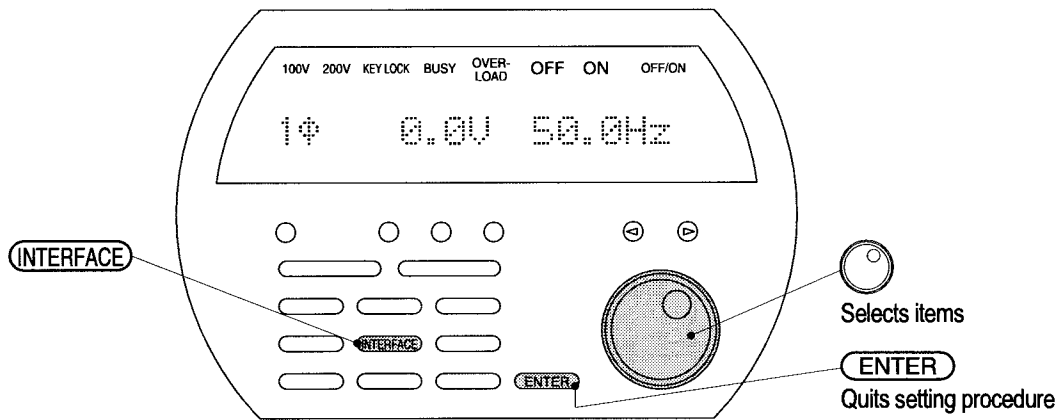

To use an RS-232 interface, connect the system to a computer for use with an RS-232 straight cable and carry out settings of "Selection of interface", "Transfer rate", "Delimiter for sending", "Parity", "Stop bit" and "Character length".

Selecting the interface

9. RS-232 Interface

1 Press **INTERFACE** to show the interface setting screen.
* "GPIB" is set on shipping.

2 Turn the dial to select "RS-232".

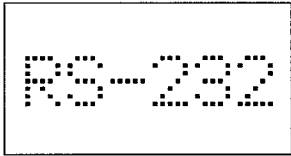
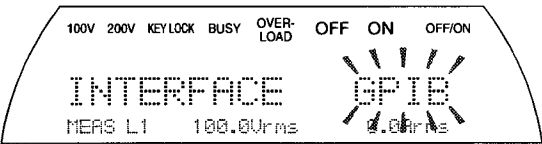

EPO 2000S/2000X

Setting the transfer rate

- 1 Press **(INTERFACE)** to show the transfer rate setting screen.

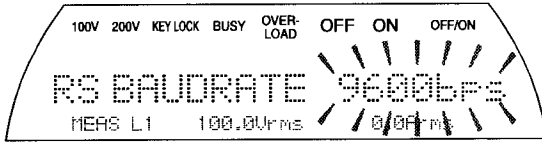

- 2 Turn the dial  to select the transfer rate.

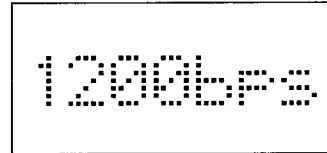

Select a transfer rate out of 1200, 2400, 4800, 9600 bps.

Setting a delimiter for sending

- 1 Press **(INTERFACE)** to show the delimiter setting screen.

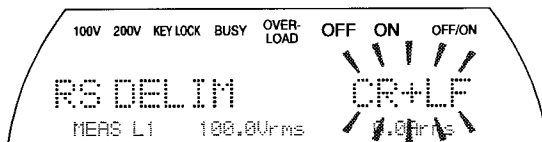

- 2 Turn the dial  to select the delimiter.

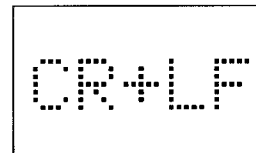

Select one out of delimiters: CR+LF, CR and LF.

Setting the parity

- 1 Press **(INTERFACE)** to show the parity setting screen.

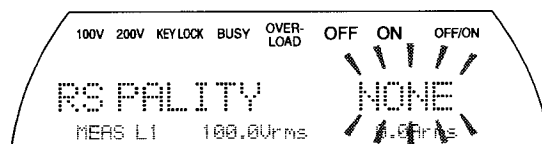

- 2 Turn the dial  to select the parity.

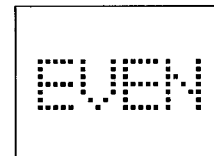

Select parity out of NONE, EVEN and ODD.

Setting the stop bit

- 1 Press **INTERFACE** to show the stop bit setting screen.

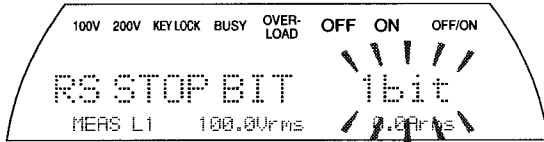

- 2 Turn the dial  to select the stop bit.

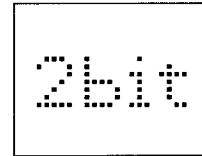

Select either of 1bit and 2bit for the stop.

Setting the character length

- 1 Press **INTERFACE** to show the character length setting screen.

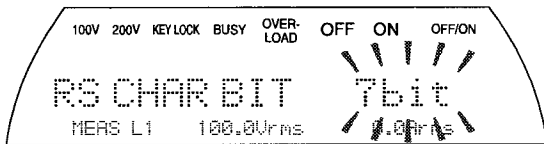

- 2 Turn the dial  to select the character length.

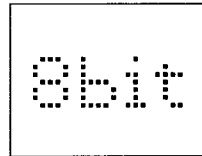

- 3 Press **INTERFACE** or **ENTER** to quit the setting procedure, and the display returns to the normal screen.

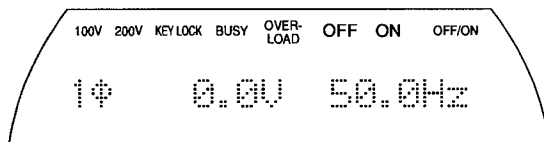

Select either of 8bit and 7bit for the character length.



Attention!

Once RS-232 is selected, an **REM** indication appears and the system disables operations other than **INTERFACE** and **OFF/ON** button operations. The **[OFF/ON]** button is available only to turn off the output for emergency stop.



Memo

[Difference between RS-232 and GPIB]
Control of RS-232 interface differs from that of GPIB interface as listed below:

- Does not support parallel connection of devices.
- Does not specify addresses because the system performs one-to-one data communications.
- Does not have the service request (SRQ) function.
- Does not have the remote/local function.



Attention!

- Both GPIB and RS-232 cannot be used simultaneously. The user must select either of them.
- The initial state (on-shipping condition) has GPIB set for default.



Attention!

Interface related parameters are stored in the battery-backup memory. When the backup battery deteriorates, the voltage lowers and as a result, backup data may be erased or destroyed. Such a failure is checked when the system power is turned on and the system is initialized to the state of factory default.
For further information, refer to the section titled "Backup battery" in Chapter 10 "Maintenance".



Attention!

- When RS-232 is under selection, only the **INTERFACE** and **OFF/ON** buttons are operable. The **OFF/ON** button is available only to turn off the output for emergency stop.

Connection of RS-232 cable

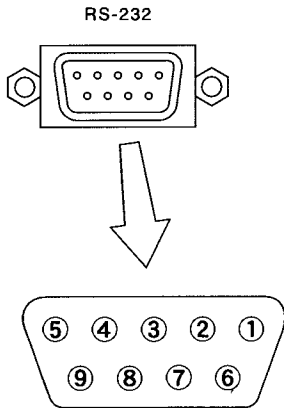

Pin array of RS-232 connector

Connect with a cable the controlling computer and the unit at the RS-232 connector on the rear panel of the unit.

The RS-232 connector of P-STATION/EPO, which conforms to common PC-AT compatible computers, accepts marketed straight cables.

Select a cable protected with double shield that is connected to the metallic shell of its connector in order to avoid unnecessary radiation of electromagnetic fields. Use of an inferior cable may give disturbances to the surroundings.

Connection of cable available for connection is shown below.

P-STATION EPO			PC-AT compatible machine	
Pin No.	Name of signal		Pin No.	Name of signal
1	N.C. No connection	→	1	CD Carrier Detect
2	TD Transmitted data	→	2	RD Received Data
3	RD Received data	←	3	TD Transmitted Data
4	DSR Indicates the partner is active. If not active, sending from this device will be kept waiting.	←	4	DTR Data Terminal Ready
5	SG Signal ground (connected to chassis)	—	5	SG Signal Ground
6	DTR Indicates this device is active.	→	6	DSR Data Set Ready
7	CTS Indicates the partner is receptive. If not active, sending from this device will be kept waiting.	←	7	RTS Request To Send
8	RTS Indicates this device is receptive.	→	8	CTS Clear To Send
9	N.C. No connection	→	9	RI Ring Indicator
DSUB type 9-pin male (fixing screw: inch)			DSUB type 9-pin female	

Handshake

The user can make use of hardware handshake in a P-STATION/EPO system.

Handshake is performed by DTR-DSR/CTS-RTS through connection via straight cable described in "Connection of RS-232 cable".

Details of handshake operation

a) Reception from controller

- Depending on the condition of reception buffer (255 characters), this product performs the following processing:

- If about 2/3 or more is used → disables RTS and DTR.

- If about 2/3 or more is emptied → enables RTS and DTR.

b) Transmission to controller

- Suspends transmission temporarily if either of the following condition is entered:

- CTS is disabled.

- DSR is disabled.



Sample RS-232 program

The following section introduces samples of remote control that uses RS-232 interface. Presented here is a case of simple setting in which Visual Basic (excluding Learning EDITION) is used.

The contents of program is almost the same as "a) Setting" of the sample GPIB program, a "Case in which Visual Basic and National Instruments' GPIB interface board are used" in Chapter 8.

For the use of program messages, which is similar to GPIB, also refer to "Sample GPIB program" of Chapter 8 "GPIB Interface".

Example of Visual Basic (Setting)

This is a simplest program of initialization followed by setting of arbitrary voltage and frequency, then turning on the output.

To use RS-232 with Visual Basic, it would be easy to resort to communication control (MSComm). From "Component" of Visual Basic "Project" menu, select "Microsoft Comm Control" to reach this communication control.

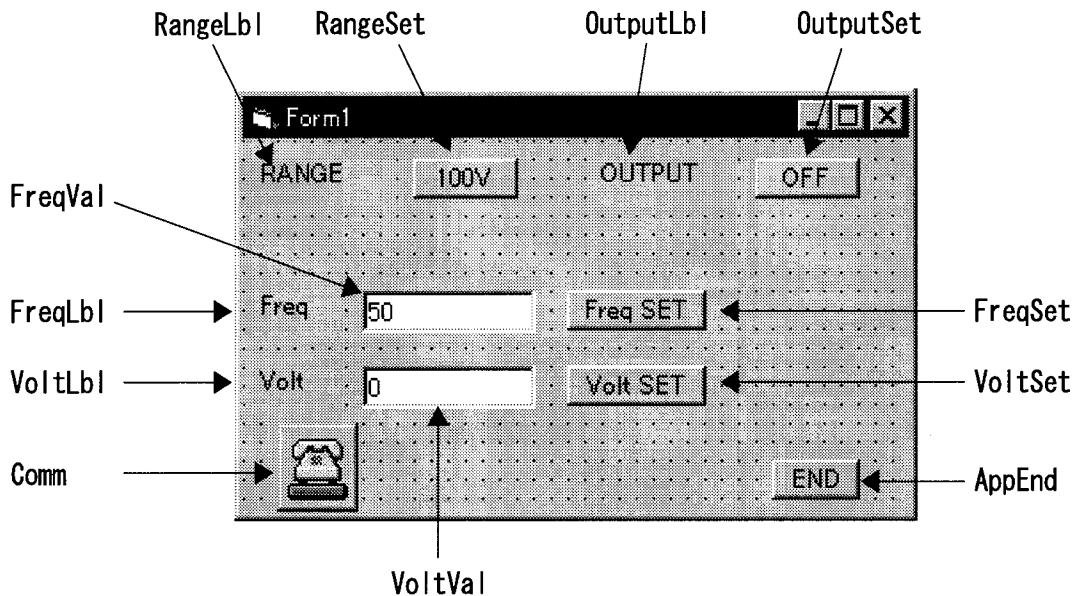

```

Option Explicit
Dim DELIM As String
Dim Rng As Boolean
Dim Out As Boolean

Private Sub AppEnd_Click()
    Comm1.PortOpen = False      ' Close the port
    End
End Sub

Private Sub Form_Load()
    Comm1.Settings = "9600,N,8,1" ' Set communications conditions
    Comm1.Handshaking = comNone  ' Set conditions of handshake
    Comm1.CommPort = 1           ' Specify Port 1
    Comm1.PortOpen = True       ' Open the port

    Rng = False
    Out = False
    DELIM = Chr(&H13) & Chr(&HA)
End Sub

Private Sub FreqSet_Click()
    Comm1.Output = "FRQ" & FreqVal.Text & DELIM ' Set the frequency
End Sub

```

```

Private Sub OutputSet_Click()
    If Out = False Then
        Comm1.Output = "OUT 1" & DELIM      ' Set the output to ON
        OutputSet.Caption = "ON"
        Out = True
    Else
        Comm1.Output = "OUT 0" & DELIM      ' Set the output to OFF
        OutputSet.Caption = "OFF"
        Out = False
    End If
End Sub

Private Sub RangeSet_Click()
    If Rng = False Then
        Comm1.Output = "RNG 1" & DELIM      ' Set the range to 200V
        RangeSet.Caption = "200V"
        Rng = True
    Else
        Comm1.Output = "RNG 0" & DELIM      ' Set the range to 100V
        RangeSet.Caption = "100V"
        Rng = False
    End If
End Sub

Private Sub VoltSet_Click()
    Comm1.Output = "VLT" & VoltVal.Text & DELIM      ' Set the voltage
End Sub

```

10

Maintenance

■ This chapter briefs backup battery and calibration.

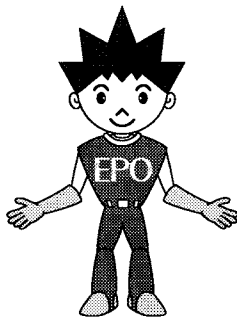

Backup battery

An EPO 2000S/2000X unit uses a lithium battery for backup power.

The battery can backup the unit about five years if the unit is left un-powered. However, this period varies with the temperature and working conditions.

When the battery is consumed, a message of "BACKUP MEMORY LOST" appears on the display when the unit is powered up. The unit starts up with all stored data initialized. Frequent occurrence of this condition indicates that the battery should be replaced. Contact the company or the dealer.

Calibration

If your EPO 2000S/2000X unit is found to be demanding calibration, contact the company or the dealer.

11

Solution of Trouble

■ This chapter describes possible causes and measures when the user encounters difficulty in operation of the system.





Fault diagnosis

When the power to the unit is turned on, the unit carries out diagnosis over its parts. If any error is detected on booting, the control stops power energizing to the major internal power sections and displays an error message in order to prevent the trouble from expanding.

The following table describes causes and necessary measures for each message.

Message	Cause	Measures or description
SYSTEM FAIL 001	Corrupt contents of internal ROM (program memory)	The system will not boot up, with the message only displayed. Possibility of failure. Note the message and contact the company or the dealer.
SYSTEM FAIL 002	Errors found in result of operation check of internal RAM	
SYSTEM FAIL 003	No response from control section	
SYSTEM FAIL 004		
SYSTEM FAIL 005	Trouble found in control section	
SYSTEM FAIL 006	Trouble found in signal generation section	
SYSTEM FAIL 007	Wrong connection of system cable, or failure of power energizing to all power sections within 15 seconds.	First turn off all power switches then turn them on again.
BACKUP MEMORY LOST	Data stored in battery-backup memory has been lost.	When the message is displayed, initialize all stored data to the factory settings and boot the system. If this error frequently occurs, backup battery is deteriorated. Contact the company or the dealer because battery replacement is regarded as "repair".
	The first power up after version up of program memory	When the message is displayed, initialize all stored data to the factory settings and boot the system.
PARAMETER CLEAR	Alteration of system cable connection (message is displayed only on master unit)	When the message is displayed, initialize those contents stored by the storage function to the factory settings and boot the system.

Settings retained by backup battery

The table below lists settings that will be stored and maintained by the backup battery even when the power switch is turned off. If the fault diagnosis function finds any problem, the control erases the data stored in the battery-backup memory and initializes the data to the factory settings according to the table below.

Settings supported by backup battery	Factory setting	Problem found by fault diagnosis		
		Damaged data in memory	Version-updated program memory	Alteration of system cable connection (only master)
Data stored by storage function	( 5 "Versatile Use - for advanced users -")	To be erased		
Key lock	Off			
Selection of interface	GPIB	To be erased		Not to be erased
GPIB address	2			
GPIB delimiter	CR+LF			
RS-232 transfer rate	9600bps			
RS-232 delimiter	CR+LF			
RS-232 parity	None			
RS-232 stop bit	1bit			
RS-232 character length	8bits			
Beep	On			



Protective functions

These functions monitor the internal condition and they exert protective functions if any error is detected. Two types of protective functions are provided: output restraint and shutoff of power.

1. When the protective operation of output restraint is exerted, the system is protected from overload and **OVER-LOAD** lights up. When overload or other error disappears, the system automatically restored to normal output.

2. In the case of a severe error, the function shuts off the power to internal major power sections to secure safety.

If beep warning is set to ON, the system warns with beep during output restraint and power shutoff period.

Subject of protection	Status under protection			Description
	Message on power shutoff	Output restraint	Power shutoff	
Output current restraint	(Power will not be shut off.)	○		Restrains the output current to a constant level or lower. Particularly, waveform clips when AC output is supplied.
Output power restraint				Restrains the output power to a constant level or lower. Particularly, waveform clips when AC output is supplied.
Power amplifier input voltage error	SYSTEM DOWN FL0201 (last two digits indicate the unit number)	○	○	Turns off the output or shut off the input depending on the degree.
Overcurrent in power amplifier	SYSTEM DOWN FL0301 (last two digits indicate the unit number)	○	○	Shuts off the input.
Overheated internal heat sink	SYSTEM DOWN FL0601 (last two digits indicate the unit number)	○	○	Shuts off the input by detecting suspended operation due to blown fuse etc.
DC power section inoperative	SYSTEM DOWN FL0101 (last two digits indicate the unit number)		○	Disconnection arouse inside.
No response from unit	SYSTEM DOWN FL0400 (last two digits are always 00)		○	

Troubleshooting

If the user experiences a condition that would lead to potential system failure during EPO 2000S/2000X operation, refer to the following section to check for wrong operation, procedure, or connection.
 If any of the following descriptions does not apply to the condition, do not turn on the power and contact the company or the dealer.

Phenomenon on power turning on

Phenomenon	Cause or conditions	Measures or description
Will not start any action on power turning on.	Is the power input positively supplied?	Ensure the power input is positively supplied.



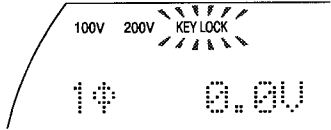
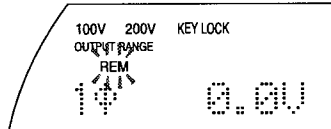

Buttons are inoperable

Phenomenon	Cause or conditions	Measures or description
Almost all buttons do not work.	Is KEYLOCK lighting? 	Turn off key lock. (☞ See the section of "Key lock", Chap. 7 "Useful Functions".)
	Is REM lighting? 	If RS-232 is selected for interface, then change it to GPIB. (☞ See "Setting for GPIB use", Chap. 8 "GPIB Interface".) If GPIB is selected for interface, the keypad of the unit is inoperable when the system is controlled by the PC.

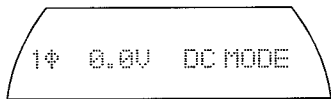

Phenomenon relating to voltage setting

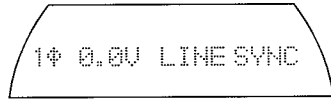
Phenomenon	Cause or conditions	Measures or description
Cannot switch voltage range from 200V to 100V.	If AC output has been selected, is the setting of output voltage higher than the phase voltage of 150V?	Set the voltage to 150V or lower.
	If DC output has been selected, is the setting of output voltage higher than 212V?	Set the voltage to 212V or lower.

Phenomenon relating to frequency setting

Phenomenon	Cause or conditions	Measures or description
Cannot set frequency.	Is DC output selected? 	Select AC output before going ahead. ( See "Using the unit as a DC power supply", Chap. 5 "Versatile Use".)
	Is line synchronization enabled? 	Disable line synchronization before going ahead. ( See "Line synchronization", Chap. 7 "Useful Functions".)

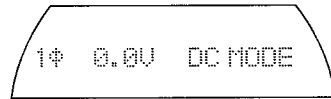
Phenomenon relating to line synchronization

Phenomenon	Cause or conditions	Measures or description
Cannot enable line synchronization.	Is the reset frequency for the line synchronization OFF moment (50 Hz or 60 Hz) out of the range between the upper limit and lower limit to the frequency?	Change the value of upper and/or lower limit frequency. ( See "Setting limits to output", Chap. 4 "Fundamental Use".)
	Is DC output selected? 	Change to AC output. ( See "Using the unit as a DC power supply", Chap. 5 "Versatile Use".)

Phenomenon relating to overload

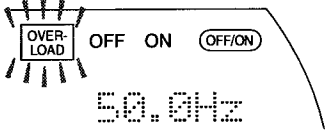
Phenomenon	Cause or conditions	Measures or description
Overload lamp lights up.	Is the system in overloaded condition?	Check the load and ensure the load is within the rated ranges.
	Was it noticed on an output turning ON occasion?	Lamp lighting for a short time is normal. A rush current triggered the protective function and the output was restrained. However, the measurement of rush current is not correct because waveform clips.

Phenomenon relating to measurement function

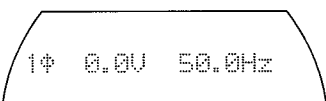
Phenomenon	Cause or conditions	Measures or description
L1/L2/L3 <input type="radio"/> does not function.	Is it on EPO 2000S?	This button has no effects on EPO 2000S unit.
	Is single-phase selected for phase-mode?	This button has no effects in single-phase mode.
		

Phenomenon relating to storage function and preset

Phenomenon	Cause or conditions	Measures or description
Cannot recall memory.	Is the phase mode being recalled different from the current phase mode on your EPO 2000X unit?	EPO 2000X does not allow recalling an address at which different phase mode is stored.
Pressing PRESET does not recall.		

Phenomenon on power turning off

Phenomenon	Cause or conditions	Measures or description
The unit persists operation for a while after turning off the power.	This is normal. Operation automatically stops when the internal voltage has lowered down to a sufficiently safe level.	Do nothing and wait for a while. Operation will stop about five second later.

If a motor is connected as load

Phenomenon	Cause or conditions	Measures or description
When the unit is supplying power to the motor, output occasionally stops by some chance. Or, the power input is unexpectedly shut off.	When the system is providing power to a motor, the rotor generally continues to run by the inertia even after stop of the power supply. At this moment, a reverse voltage is applied to the terminal that has been supplying the power. If the user turns on the output of P-STATION/EPO in this situation, this voltage may flow back to EPO depending on the condition. This may cause abnormal rise of power supply voltage within the EPO unit, and, at worst, resulting in equipment damage. To protect the unit from this, detection of an abnormal rise of internal voltage automatically turns off the output and, depending on the degree, shuts off the input power.	<p>Do not turn on the output when the motor continues turning after turning off the output.</p> <p>Wait until the rotation stops before turning on the output.</p> <p>Take extreme care because the operation is likely to give impact in the EPO unit.</p>

If a transformer is connected as load

● 11. Solution of Trouble ●

Phenomenon	Cause or conditions	Measures or description
Current seems abnormal and saturated in the load of transformer.	<p>Although the output of P-STATION/EPO is controlled by its electronic circuitry to prevent abnormal DC voltage from arising, complete 0V is not achieved due to the limit of control.</p> <p>This small DC voltage excites the core by the force of DC and thus the exciting current of the transformer sometimes presents abnormal level depending on the transformer connected.</p>	The DC offset voltage of EPO is typically $\pm 30\text{mV}$. When to connect a transformer as load, take into consideration the effects of this value.



Frequently asked questions and answers to them

(Questions)

(Answers and explanation)

Can I superimpose AC on DC?



No, you cannot do that with P-STATION/EPO units. However, you can do it with our P-STATION/series [Q].

I want to perform a test to give quick change of voltage or frequency to the load. What should I do?



You can do it using the storage function. You can change the condition with the output kept ON when recalling the memory if you have stored in memory settings of which a set of three parameters ("output voltage range", "line synchronization" and "AC/DC mode") are the same as the current parameters respectively in advance.

* For more complicated tests, it is recommended to use our P-STATION/series [Q].

I want to use the unit around power supply voltage of 100V AC. Is this possible?



It is possible to use the unit in the range of 85 to 132V power supply voltage although there is no stipulation on rating. However, output power is restricted to about 800VA in order to restrain the power supply current to about 15A or lower to ensure safety even if wiring from power outlet is permitted taking into consideration possibility of a common 100V power distribution system.

I need a system of 4 or 6 kVA but do not have to change the connection. Is there any system configuration that is less expensive?



Our product, EPO 2000X, is intended to allow extension between master units.

One of major advantages of the unit is to allow capacity augmentation or three-phase configuration through simple system enhancement only on as-necessary basis and, on ordinary occasions, they are used in different places separately for independent use.

If your plan is to use your units in a particular intention without modifying connection, then our family products, EPO 4000S (single-phase 4 kVA) and EPO 6000M (multi-phase system 6kVA) are ready for your configuration.

(Questions)

Our system consists of two EPO 2000X units. Can we operate the system from the operation panel on which "SLAVE" is shown on the display?



(Answers and explanation)

You can operate the system from only one unit (the unit whose display does not show "SLAVE") in the system consisting of two or three EPO 2000X units.

Our system consists of two EPO 2000X units. We want to separate the units to use them individually. What will be the contents in memory after separation?



The unit on which "SLAVE" is displayed stores the settings that were used when that unit worked as a single unit. If the unit is powered independently, the original settings will be retrieved for operation.
In the master unit, however, the data in memory will be initialized to the factory settings because the change of system configuration is detected.
Further, interface related data is not affected by the above alteration and remains unchanged.

We are using the system for three-phase load and our desire is to monitor not only the line-to-line voltage but also line-to-line current. What can we do?



The units do not have a function to display line-to-line current. Only phase current is measured and displayed.

12

Rating

- Rating of EPO 2000S/2000X



			EPO 2000S	EPO 2000X (allows two or three unit combination)		
			2kVA	2kVA	4kVA	6kVA
Output (AC mode)	Capacity		2kVA	2kVA	4kVA	6kVA
	Phase mode correspondence		Single-phase		Single-phase or single-phase three-wire	Single-phase or three-phase
	Voltage setting range *1		100V range	0V~150.0V	Phase voltage: 0 to 150.0V	
			200V range	0V~300.0V	Line-to-line voltage: 0 to 300.0V	Line-to-line voltage: 0 to 259.8V
	Maximum current *2		Single-phase 100V range	20A	40A	60A
			Single-phase 200V range	10A	20A	30A
			Single-phase three-wire *3 100V range	—	20A	—
			Single-phase three-wire *3 200V range	—	10A	—
	Three-phase *3 100V range		—	—	—	20A
	Three-phase *3 200V range		—	—	—	10A
	Maximum rush current (RMS in short time)		2.8 times the maximum current (RMS)			
	Maximum peak current (peak value) *4		4 times the maximum current (RMS)			
	Power factor of load		0 to 1 (leading or lagging phase)			
	Distortion factor		0.5% or less			
Starting phase on output turn-ON		Either of 0, 90, 180 and 270 degree by selection				
Frequency		Setting range: 5.0 to 550.0Hz (resolution 0.1Hz) Setting accuracy: within $\pm 0.01\%$ of the setting ; Stability: within $\pm 0.005\%$ of the setting				
Line synchronization		Supplies AC output synchronized to power line frequency				
Output (DC mode) *5	Voltage setting range		100V range	0 to 212.0V (resolution of 0.1V)		
			200V range	0 to 424.0V (resolution of 0.1V)		
	Maximum current		100V range	9A	18A	27A
			200V range	4.5A	9A	13.5A
Maximum output power		1.3kW		2.6kW	3.9kW	
Output voltage stability	Current fluctuation to load		40.0 to 120.0Hz: within $\pm 0.1\%$, 120.1 to 500.0Hz: within $\pm 0.5\%$ (typ)			
	Input voltage fluctuation to power supply		within $\pm 0.2\%$			
	Fluctuation to ambient temperature		within $\pm 100\text{ppm}/^\circ\text{C}$ (typ)			
Input	Voltage and frequency		170 to 250V *6, 48 to 62 Hz			
	Number of phases		Single-phase			
	Efficiency and power factor		Efficiency 76% or higher (typ), power factor 97% or higher (typ) with input voltage of 200V			
	Input current *7		14A or less	14A or less (per unit)		
Power consumption		2.8 kVA or less	5.6 kVA or less	8.4 kVA or less		
Function	Measuring function *8	AC mode *9	Voltage	RMS : 170V/340V range (self switching), resolution 0.1V, accuracy within $\pm 1\%$ FS Peak : 240V/480V range (self switching), resolution 0.1V, accuracy within $\pm 3\%$ FS		
			Current	RMS: 14A/78A/70A range (self switching), resolution 0.01A, accuracy within $\pm 1\%$ FS Peak: 20A/40A/100A/200A/400A range (self switching), resolution 0.01A (0.1 A for 200 A/400 A), accuracy within $\pm 3\%$ FS		
		Effective power Apparent power and power factor	2.2 kW/22 kW range, resolution 0.01 kW (at 2.2 kW)/0.1 kW (at 22 kW), accuracy within $\pm 3\%$ FS Calculated from voltage, current and effective power measurements and displayed			
		Peak current holding function	20A/40A/100A/200A/400A range, resolution 0.01A (0.1A for 200A/400A), accuracy within $\pm 5\%$ FS			
	DC mode	Voltage	Mean value: 240V/480V range (self switching), resolution 0.1V, accuracy within $\pm 1\%$ FS			
		Current	Mean value: 20A/40A/100A/200A/400A range (self switching), resolution 0.01A (0.1A for 200A/400A), accuracy within $\pm 1\%$ FS			
		Power	Calculated from voltage and current measurements and displayed			
	Others		Fault diagnosis function, protective function, storage function, preset function limiter function, GPIB/RS-232 interface, external keypad entry, key lock function, beep warning			
Environment, mass etc.	Withstand voltage *10		1.5 kV AC, 50/60 Hz for one minute			
	Insulation resistance (at 500V DC) *10		10M Ω or higher	5M Ω or higher	3.3M Ω or higher	
	Ambient temperature and humidity		Operation: 0 to 40°C; Storage: -10 to 50°C, 10 to 90% RH (no condensation)			
	Mass *11		25kg	25kg(per unit)		
Dimensions		448W \times 176 (191) H \times 651 (685) D (per unit) * Units in mm; values in parentheses include projections				

Rush current versus supply time

* $V_o = 100.0V$ (100V range) or $200.0V$ (200V range), $f = 50Hz$, at Power-ON phase 0°

This indicates the time (rush supply time) spent until the output is restrained by the protective circuit operation when rush current is applied to a resistance load.

Rated current = 20A (100V range), 10A (200V range)

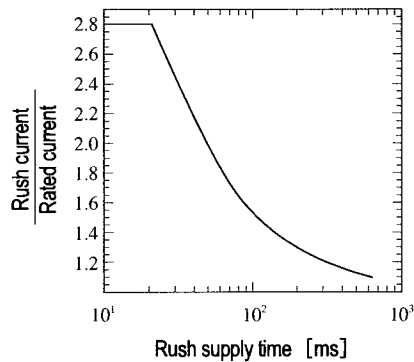
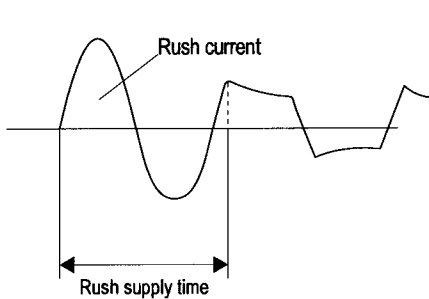

Maximum output current versus frequency

* Maximum current decreases at frequency lower than 40Hz.

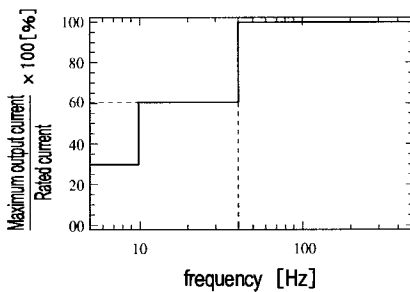

Maximum output current versus output voltage (AC mode)

* Maximum current decreases at voltage higher than 100.0V (for 100V range) or 200.0V (for 200V range).

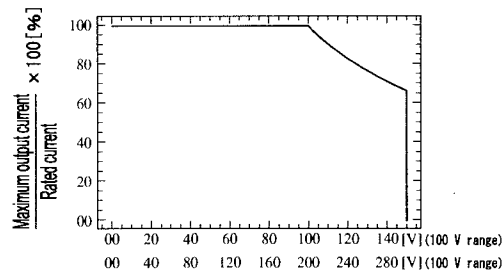

Remarks: [A] means [Arms], [V] means [Vrms] unless any other special description is given. Signal waveform is a sinusoidal wave.

- *1 Setting resolution is 0.1V for phase voltage and 0.2V for line-to-line voltage.
- *2 With sinusoidal wave. Output current decreases if output frequency is 40 Hz or lower.
- *3 With phase current.
- *4 A short period until mean value protection operates. However, repeated application is allowed to capacitor input type rectifying load (at 48 to 62 Hz).
- *5 DC mode cannot be used in single-phase three-wire or three-phase system.
- *6 EPO 2000S and EPO 2000X units are operable at 100V although the output is limited to 800 VA.
- *7 At input voltage of 200V.
- *8 Measurement accuracy is for full scale (FS) of each measurement range.
- *9 Effective measurement range of voltage and current is 40 to 500 Hz.
Effective measurement range of effective power is 45 to 65 Hz.
- *10 Stipulated with chassis - power supply input in package versus output, chassis - output in package versus power supply input.
- *11 Accessories and optional items are excluded.

13

Terminology

- In this chapter, I will try to elucidate terms related to AC power supply.

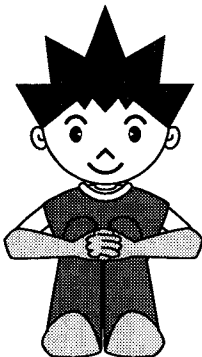



Elucidation of terms

■ AC power supply/AC stabilizing power supply

When electricity is transferred through power transmission lines from power stations of power companies via substations to power switchboards and wall outlets to provide power, the value and waveform of voltage are deformed by effects of impedance of the supplying wires and loads.

To solve the above problem, we have some means to stabilize the power at the reception end. Conventionally used solutions include devices that use saturable reactors and method that controls slide regulators by servo, which had such remarkable defects that response speed is slow and waveform is not improved yet. To replace these methods, various devices that use electronic circuitry have been proposed recently.

Among others, our P-STATION/EPO employs a power amplifier system and provides AC voltage of low distortion and high stability by means of incorporated signal generator.

■ Higher harmonic current

Household appliances and industrial applications often use switching power sources. A capacitor input rectifying circuit, which is used in their power input section has a drawback that the input current is greatly distorted and deformed so that it contains a number of harmonics.

If high volume of such current flows into power lines, the voltage will be distorted so that other equipment malfunctions, transformers are overheated and other problems are caused, possibly resulting in accidents.

P-STATION/EPO, which adopts a circuit to effectively restrain this harmonic current, controls the level of harmonics down to almost the regulatory value and, at the same time, markedly improves the power factor (about 97%, typ).

■ Immunity to power supply harmonic components

The product has immunity to harmonic components contained in power supply so that the output will not be affected by them even when harmonic components are contained in the power supply voltage due to harmonic current generated by other electric equipment.

■ Rush current (or inrush current)

In motors and other electrical products that use capacitor input rectifying circuit in the power input section, a considerably high current flows in a short time immediately after turning on the power switch compared to the rating condition. This current is called a rush current.

If the power supply cannot afford to provide this current sufficiently, some products, without getting necessary power, may not be started depending on the condition.

If this high current runs, the impedance of the power supply line causes a voltage drop so that the supply voltage may be lowered. Therefore, we have a certain regulation that limits this effect to a constant level or lower. This test, however, must be performed with a power supply that has a sufficient rush supplying capacity.

To support such forms of application, our P-STATION/EPO series have ability to provide rush current that is 2.8 times the rated current. Users do not have to furnish their facilities with another power supply of excessive capacity to provide rush current.

* Example of rush current
Power drill
(rated to 100V AC 260W)
Top: voltage (100V/div)
Bottom: rush current (10A/div)

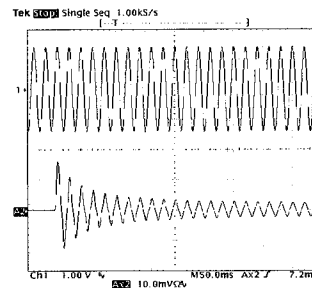

Even in a small power drill, a 15 Apk (about 10 Arms) rush current flows just after power charging. This rush current is four times the rated current of 2.6 Arms.

■ Capacitor input load

Most of switching power supply units used in different equipment adopt an input rectifying circuit of capacitor input type because of the simplicity and low-cost of the circuit. Input current to the equipment in this configuration has such waveform that the current flows only around the peak value of the given sinusoidal voltage. This waveform contains many harmonic components and the ratio of peak value to RMS value (Crest Factor, CF value) is as high as 1.5 to 2 times that of resistance or other linear loads (CF = 1.41)

To supply low-distortion voltage to these loads, therefore, deliberate measures have been taken in P-STATION/EPO so that current of CF = 4 will be supplied at the maximum (for output capacity 2 kVA in precision mode).

■ Output stability (output voltage stability)

Various types of performance are required in power supply. Among them, particular one is the resistance to the effects of load fluctuation and power input voltage fluctuation. This characteristic is called "Output stability".

● Current fluctuation versus load change

This means the fluctuation of output voltage due to the change of load condition. In general, the ratio of the voltage change in a load-connected condition against the voltage in a no-load condition (no load connected) is expressed in [%].

● Input fluctuation versus power supply change

This means the fluctuation of output voltage caused by the change of power input voltage. In P-STATION/EPO, the ratio of the output voltage change (at rated output) against input voltage variance (170 to 250V) is expressed in [%], which is stipulated as the rating.

● Fluctuation versus ambient temperature change

This means the fluctuation of output voltage against the change of ambient temperature.

■ Tolerance to instantaneous power interruption and fluctuation of power supply voltage

In general commercial power supply lines, power companies provide power environments of a constant quality. Even if an unexpected natural disaster such as lightning takes place and causes trouble in power transmission lines, they change lines in a second in order to minimize the influence of power failure.

However, in this short period of time to be spent for the line change, the power supply voltage becomes 0 (this is called an instantaneous power interruption), or lowers to an abnormal level. Those electrical products that are not able to endure this interruption cannot continue proper operation.

Our P-STATION/EPO units have sufficient tolerance ability against these phenomena even in a relatively poor power environment, and they can minimize the impact in the output.

■ Stability to capacitive load

If your AC power source is of power amplifier type, such as P-STATION/EPO, it provides feedback via an electronic circuit to compensate the fluctuation in output voltage due to load variances. However, if a capacitive load of extremely high level is connected, stability may be broken, causing oscillation and other abnormal phenomena.

Therefore, our P-STATION/EPO is provided with a consideration so that users can select the compensation mode to cope with the trouble in the above situation. The tolerance against capacitive load is about 10 μ F in "Precision mode" to ensure high accuracy while "High stability mode" allows the user to connect a load of maximum 150 μ F to secure stability.

■ Application to RF anechoic chamber

An RF anechoic chamber (or a shielded room), which is a facility to measure unnecessary radio noise produced from various electronic devices and verify the legitimacy of the device to EMC standards, is required to have an extremely low noise environment so that the detection and measurement of electromagnetic wave emitted from the subject device will not be affected by noise.

Therefore, a noise filter with particularly high restraining effects is used in the power input section of the anechoic chamber. However, in general, operation may become unstable under conditions of the capacity being several tens μ F or higher capacitance, with the power supply unit of power amplifier type providing only insufficient compensation.

In high stability mode, even in the above situation, our P-STATION/EPO will ensure high stability, which does not prevent selection of filter.

■ Effective power and apparent power

Assuming that an AC power supply is providing power to the load, let the load current as I_L and voltage as V_L (here both I_L and V_L are RMS) and calculate the product ($|I_L| |V_L|$) of absolute values of the both by multiplication. This is called apparent power and is expressed in [VA].

Thus, the following term out of the power provided from the power supply :

$$\frac{1}{T} \int_0^T \dot{i}_L v_L dt$$

($\dot{i}_L v_L$: instantaneous value)

is called effective power and is expressed in [W].

The ratio of these two values ($[W]/[VA]$) is called power factor.

In other word, it is considered that apparent power is the power that the AC power supply is going to provide, effective power is the power utilized as certain energy in the load, and power factor is the rate of the used power out of the supplied power in the load.

P-STATION/EPO determines these values by calculation, similar to the above, from the instantaneous value of detected voltage and current.

■ RMS value and peak value

To express the magnitude of voltage, for example, we have several forms of expression available in the case of AC voltage.

Most common one is RMS value. This expresses the magnitude with the DC voltage that exerts the same work. A common expression of "100V AC" means an AC current that has an RMS value of 100V. To indicate that the value is in RMS, notation of 100 [Vrms] is used.

A peak value is the voltage at the instant at which the voltage is the highest in the course of waveform. Notation of [Vpk] is used to express this.

Also for AC current, RMS values in [Arms] and peak values in [Apk] are used similarly to AC voltage.

WARRANTY

NF CORPORATION certifies that this instrument was thoroughly tested and inspected and found to meet its published specifications when it was shipped from our factory.

All **NF** products are warranted against defects in materials and workmanship for a period of one year from the date shipment. During the warranty period of, **NF** will, at its option, either will repair the defective product without any charge for the parts and labor, or either repair or replace products which prove to be defective. For repair service under warranty, the product must be returned to a service center designated by **NF**. Purchaser shall be prepay shipping charge, duties, and taxes for the product to **NF** from another country, and **NF** shall pay shipping charge to returned the product to purchaser.

This warranty shall not apply to any defect, failure or damage caused by improper use, improper or inadequate maintenance and care or modified by purchaser or personnel other than **NF** representatives.

NF CORPORATION

WABUN: (≈509129-1)

If there are any misplaced or missing pages, we will replace the manual. Contact the sales representative.

NOTES:

- Reproduction of the contents of this manual is forbidden by applicable laws.
- The contents of this manual may be revised without notice.
- Information provided in this manual is intended to be accurate and reliable. However, we assume no responsibility for any damage regarding the contents of this manual.
- We assume no responsibility for influences resulting from the operations in this manual.

Copyright 2000, **NF CORPORATION**

EPO 2000S/EPO 2000X Instruction Manual

NF CORPORATION

3-20 Tsunashima Higashi 6-chome, Kohoku-ku. Yokohama-shi
223-8508, JAPAN

Phone: 81-45-545-8128 Fax: 81-45-545-8187

