



PROGRAMMABLE AC POWER SOURCE

DP020AGS

INSTRUCTION MANUAL

DA00104049-001

PROGRAMMABLE AC POWER SOURCE

DP020AGS

INSTRUCTION MANUAL

Preface

Thank you for purchasing our Programmable AC Power Source DP020AGS.

For safe and correct use of the electrical product, please first read “[Safety Precautions](#)” on the next page.

■ Alert symbols in this manual

This manual uses the following alert symbols. The instructions by these alert symbols shall be carefully obeyed to ensure equipment operator's safety and prevent damage to equipment.

WARNING

Equipment handling could result in death or serious injury. This symbol contains information to avoid such risk.

CAUTION

Equipment handling could result in minor or moderate injury, or property damage. This symbol contains information to avoid such risk.

■ This manual consists of the following chapters.

If it is the first time for you to use this product, start with “1. Outline.”

1. **Outline:** Explains the overview, configuration, and features of this product.
2. **Preparation before Use:** Explains the preparations carried out before installation or operation.
3. **Basic operation:** Explains the component names and basic operations.
4. **Advanced Operation:** Explains the operations more extensively.
5. **Description of Screen and Menu:** Explains the screen configuration and menu composition.
6. **Remote Control:** Explains the remote control via communication interface.
7. **Options:** Explains the available options.
8. **Troubleshooting:** Explains the remedies when an error message is displayed, or when a failure is suspected.
9. **Maintenance:** Explains the methods of storage, repackaging, transportation, and maintenance.
10. **Specifications:** Provides the list of specifications of functions and performance.

■ Scope of contents

The description of this manual applies to products with firmware version 1.00 or above.

For details on checking the firmware version, see Chapter 9.4.

Safety Precautions

For safe use, ensure to obey the following warnings and considerations.

We are not responsible for damage resulting from failure to obey these warnings and considerations.

This product is an insulation Class I device (with a protective conductor terminal) complying with the JIS and IEC standards.

- Ensure you obey the instructions in this instruction manual.

This instruction manual contains instructions for safe operation and use of this product.

Before using this product, please read this manual first.

All the warning items contained in this instruction manual are intended for preventing risks that may lead to serious accidents. Ensure to obey them.

- Ensure to ground.

Ensure to connect the protective conductor terminal of the power input terminal of this product to an earth ground so that ground resistance is 100 Ω or less. If the product is not certainly grounded, an electric shock might occur.

To prevent electric shock, ensure that the protective grounding conductor is connected before you connect a cable to the power input terminals L, N.

For grounding, use the supplied power cable or an equivalent cable whose diameter is same or greater.

- Check the power supply voltage.

This product operates on the power supply voltage specified in “2.4 *Grounding and Power Connections*”. Before connecting this product to a power supply, make sure that the voltage of distribution board conforms to the power supply voltage rating of the product.

- If you notice anything strange

If this product produces smoke, unusual odor, or strange sound, immediately cut the power to the product and stop using it.

Should you encounter any anomaly like above, immediately contact us or our agent. Never use it until the repair is completed.

- Do not operate in an explosive atmosphere.

An explosion or other such hazard may result.

- Do not remove the cover.

This product has high-voltage portions inside. Never remove the cover.

When inspection into the inside of the product is needed, never allow anybody to touch the innards except our certified service engineers.

- Do not modify the product.

Never modify the product. Modification to the product may pose a new risk. We may refuse the repair of a modified product at fault.

- Prevention of electric shock by output voltage

The maximum output of this product is ± 454 V. Be careful to avoid electric shock. Directly touching the output or changing the cable connection while the output is on may cause electric shock.

- This product weights over 18 kg.

Do not carry it alone, or you may suffer physical injury.

- Do not expose this product to water.

When this product is used in wet condition, it may cause an electric shock and a fire. If this product is exposed to water, cut the power at the distribution board immediately, and contact NF Corporation or one of our representatives.

- If lightning occurs, power off this product and cut the power at the distribution board.

A lightning may cause an electric shock, a fire and a failure.

- Safety symbols

The following shows the general definitions of the safety symbols used on the product main unit and in the instruction manual.



Refer to the instruction manual

This notifies the user of potential hazards and indicates that he/she must refer to the instruction manual.



Electric shock hazard

This indicates that an electric shock may occur under specific conditions.



Protection conductor terminal

This indicates that the terminal needs to be grounded in order to prevent electric shock accidents.

Before operating the equipment, ensure to connect this terminal to an earth ground so that ground resistance is 100 Ω or less.



Warning

Equipment handling could result in death or serious injury. This symbol contains information to avoid such risk.



Caution

Equipment handling could result in minor or moderate injury, or property damage. This symbol contains information to avoid such risk.

- Other symbol



This indicates that the terminal (or external conductor for a connector) is connected to the chassis.

- Request about disposal

For environmental preservation, pay attention to the followings when you dispose of this product.

- Do not discard this product in domestic household waste. This product shall be disposed of through an appropriate industrial waste disposer.
- This product contains one coin-shaped lithium battery.
- This product does not contain mercury.

Table of Contents

Contents

	Page
Preface	i
Safety Precautions.....	ii
Contents	v
List of Figures	xi
List of Tables	xiii
1. Outline	1
1.1 Overview	2
1.2 Features	2
2. Preparation before Use	5
2.1 Check before Use.....	6
2.2 About Installation Environment.....	7
2.3 Cautions during Moving and Transportation.....	8
2.4 Grounding and Power Connections	9
2.5 Output, Sensing, and System Cable Connections	12
2.5.1 Single Output	13
2.5.2 Multi-unit system	15
2.6 Simple Operation Check	22
2.7 Calibration	23
3. Basic Operation.....	25
3.1 Component Name	26
3.1.1 Front.....	26
3.1.2 Rear	26
3.1.3 Control Panel	27
3.2 Power On/Off.....	29
3.2.1 Before Turning on the Power	29
3.2.2 Power On	29
3.2.3 Screen Display and Operations at Starting Up	29
3.2.4 The Settings Loaded after Startup	30
3.2.5 Checking the Rated Power	30
3.2.6 Power off	30
3.3 Basic Key Operations.....	31
3.3.1 Changing the Output Function (Continuous/Sequence/Simulation)	31
3.3.2 Item Selection	31
3.3.3 Using Soft-keys	32
3.3.4 Closing Windows.....	33
3.3.5 Entering Values	33
3.3.6 Entering Strings (Character String Entry Box)	34

3.3.7	Using Shortcut Operations (SHIFT Key and RECALL key).....	34
3.4	Setting Master/Slave	36
3.4.1	Opening the Master-Slave Setting Window	36
3.4.2	Setting Master/Slave	37
3.4.3	When differs from the connection of the system cable	38
3.5	Setting the Output Phase Configuration.....	39
3.6	Using the Continuous Function	40
3.6.1	Setting the AC/DC Mode and the Signal Source.....	40
3.6.2	Setting the Output Range.....	44
3.6.3	Setting Waveforms	46
3.6.4	Setting the Output Voltage (Single-phase Output).....	47
3.6.5	Setting the Output Voltage (Polyphase Output)	48
3.6.6	Setting the Output Current (Single Phase Output).....	50
3.6.7	Setting the Output Current (Polyphase Output)	50
3.6.8	Setting the Output Frequency	51
3.6.9	Setting the Output On/Off Phase	51
3.6.10	Setting Soft Start and Soft Stop	52
3.6.11	Turning the Output On or Off.....	55
3.6.12	Using the Measurement Function	55
3.6.13	Switching the Display Format (RMS/PK/AVG) of the Measured Value	56
3.6.14	Clearing the Peak-hold Value.....	57
3.6.15	Switching the Target Phase of which the Measured Values are Displayed (Polyphase Output)	58
3.7	Setting the CV/CC Mode	60
4.	Advanced Operation.....	61
4.1	Using Limiter, Setting Limiter	62
4.1.1	Using Peak Limiter	62
4.1.2	Using RMS Limiter	64
4.1.3	Using Setting Range Limit.....	66
4.1.4	About Wattage Limiter	69
4.2	Using Sequence Function	69
4.2.1	Basics.....	69
4.2.2	Parameters of Sequence Function.....	71
4.2.3	Example of Output Using Sequence Function	75
4.2.4	Process Flow in a Step	75
4.2.5	Edit a Sequence	77
4.2.6	Displaying Data List View of Sequence Memory	78
4.2.7	Load a Sequence	80
4.2.8	Execute a Sequence	81
4.2.9	Save a Sequence	83
4.2.10	Clear/Rename Sequence	85
4.2.11	Set so as the Sequence Function is Selected at Power-on	87

4.2.12	Sequence Control by CONTROL I/O	88
4.2.13	Screen Overview	88
4.2.14	Change Output Parameter during Output ON	90
4.3	Using Power Fluctuation Testing (Simulation) Function	92
4.3.1	Basics.....	92
4.3.2	Simulation Function Parameters	93
4.3.3	Output Examples Using Simulation Function	95
4.3.4	Process Flow in a Step	97
4.3.5	Editing Simulation	97
4.3.6	Opening Data List View of Simulation Memory	99
4.3.7	Loading a Simulation.....	101
4.3.8	Executing Simulation.....	102
4.3.9	Saving Simulation	104
4.3.10	Clear/Rename Simulation	105
4.3.11	Set so as the Simulation Function is Selected at Power-on	107
4.3.12	Simulation Control by CONTROL I/O	108
4.3.13	Screen Overview	108
4.4	Measuring Harmonic Current	110
4.4.1	Harmonic current.....	111
4.4.2	Measured Value Display Method	111
4.5	Measuring Inrush Current.....	112
4.5.1	Inrush Current	112
4.5.2	Peak-hold function	113
4.5.3	Measurement Method	113
4.5.4	Measurement Tips.....	114
4.6	Using Clipped Sine Wave.....	114
4.7	Using Memory Function	117
4.7.1	Basic Setting Memory	117
4.7.2	Displaying Data List View of Basic Setting Memory.....	117
4.7.3	Saving, Recalling, and Clearing/Renaming of Basic Setting Memory	119
4.7.4	Sequence Memory	123
4.7.5	Simulation Memory	124
4.8	Using USB Memory Function	125
4.9	Saving a Screenshot	126
4.10	Using Monitor Function	127
4.11	Using Remote Sensing Function	129
4.12	Using AGC Function	131
4.13	Using Autocal Function.....	134
4.14	Adjusting DC Offset.....	137
4.15	Using for Unbalanced Polyphase Output	139
4.16	Using as DC Power Supply	140
4.17	Setting Voltage or Current using External DC Input Signal	141

4.17.1	Using External Signal in AC-VCA.....	141
4.17.2	Using External Signal in DC-VCA	142
4.18	Control Using External Control Function	144
4.19	Synchronizing the Output Frequency with the Power Line or the External Signal ...	148
4.20	Turning the Output On or Off Rapidly	150
4.21	Turning Output Off in the High Impedance State	151
4.22	Enabling Automatic Output-On at Power-On.....	152
4.23	Key Lock.....	153
4.24	Beep	154
4.25	Changing the Screen Brightness.....	155
4.26	Using the Shutdown Function	157
4.27	Setting the Date and Time	158
4.28	Restoring Initial Settings	160
4.28.1	Resetting	160
4.28.2	Restoring the Factory Default State	162
5.	Description of Screen and Menu	165
5.1	Screen Configuration.....	166
5.1.1	Status Icon	167
5.1.2	Measured Value Display Items.....	168
5.1.3	Output Setting Display Items.....	169
5.1.4	Warning and Error Display	169
5.2	Menu Composition.....	169
5.2.1	Menus of the Continuous Function	170
5.2.2	Menus of the Sequence Function	171
5.2.3	Menus of the Simulation Function.....	172
5.2.4	Menus of the Memory Function.....	172
5.2.5	System menu	173
6.	Remote Control	175
6.1	Communication Interface	176
6.1.1	USB.....	176
6.1.2	RS232	178
6.1.3	GPIB.....	180
6.1.4	LAN	182
6.2	Remote/Local State Switching	184
6.2.1	Remote state.....	184
6.2.2	Local State	184
7.	Options	185
7.1	System Cable (for Multi-unit system)	186
7.2	Rack-Mount Adapter.....	186
7.3	Replacement Air Filter	190
7.4	Power Cable.....	190
8.	Troubleshooting.....	191

8.1	Error Messages and Error Handling	192
8.1.1	Error Message Screen	192
8.1.2	If An Error Message is Displayed	192
8.1.3	Protection Operation Types	193
8.1.4	Error Message List	194
8.2	When a Failure is Suspected	198
9.	Maintenance	205
9.1	Preface	206
9.2	Daily Maintenance	206
9.3	Repacking and transportation	207
9.4	Product Information Display	208
10.	Specifications	211
10.1	Output Phase Configuration	214
10.2	Output Function	214
10.3	Output Mode	214
10.4	Output Range	214
10.5	AC/DC Mode	215
10.6	Signal Source	216
10.7	Constant Voltage Output	217
10.7.1	AC Voltage Output (CV mode)	217
10.7.2	DC Voltage Output (CV mode)	218
10.8	Constant Current Output (custom)	220
10.8.1	AC Current Output (CC mode)	220
10.8.2	DC Current Output (CC mode)	221
10.9	Output Frequency	222
10.10	Output On and Off Phase, Phase Angle of Polyphase System	222
10.11	Soft Start and Soft Stop	223
10.12	Output Stability	223
10.13	Power Input	224
10.14	Withstand Voltage and Insulation Resistance	224
10.15	Measurement Function	225
10.16	Current Limiter (CV mode)	228
10.17	Voltage Limiter (CC mode)	229
10.18	Setting Range Limit Function	229
10.18.1	Voltage Setting Limit Function (CV mode)	230
10.18.2	Current Setting Limit Function (CC mode)	230
10.18.3	Frequency Setting Limit Function	231
10.19	Remote Sensing	232
10.20	AGC	232
10.21	Autocal (Output Voltage Compensation)	233
10.22	Sequence	234
10.23	Simulation	235

10.24	Clipped Sine Wave	236
10.25	External Signal Input	237
10.25.1	Voltage and Current Setting Signal Input (Signal Source VCA only)	237
10.25.2	External Synchronous Signal Input (Signal Source SYNC only)	238
10.26	General Function	239
10.27	Memory Function	240
10.28	Self-diagnosis/Protection Function	241
10.29	CONTROL I/O	242
10.30	External Interface	243
10.31	USB Memory Interface	244
10.32	Waveform Monitor Output	245
10.33	SHUT DOWN Input	245
10.34	Operation Environment	246
10.35	Externals, Mass, and Terminal Block	246
10.36	Option	247
10.37	Outline Dimensional Drawing	248

Figures and Tables

List of Figures

	Page
Figure 2-1 Power Input Connection	11
Figure 2-1 Voltage Sensing Terminal	12
Figure 2-2 Example of Connecting Cable to Voltage Sensing Terminal	12
Figure 2-3 Connecting Output and Sensing Cables	13
Figure 2-4 Maximum System Configuration	16
Figure 2-5 Connecting Outputs of Two Units Using 1P2W	19
Figure 2-6 1P3W System Connection	20
Figure 2-7 3P4W Connection of 3P4W System	20
Figure 2-8 3P3W Connection of 3P4W System	20
Figure 3-1 Component Name (Front)	26
Figure 3-2 Component Name (Rear)	26
Figure 3-3 Component Name (Control Panel)	27
Figure 3-4 Self-Test Screen when Started in a Different System than Before	29
Figure 3-5 The Rated Power Icon	30
Figure 3-6 The Root Menu	31
Figure 3-7 The Example of a Selection Box	31
Figure 3-8 The Example of a Data List Box	32
Figure 3-9 Soft-key Function	32
Figure 3-10 Switching Major Items	32
Figure 3-11 The Example of the Window with the [OK]/[Cancel] Button	33
Figure 3-12 Value Change Screen	33
Figure 3-13 The Numerical Entry Box	33
Figure 3-14 String Change Screen	34
Figure 3-15 Setting Items of Master/Slave Function	37
Figure 3-16 Output Off Operation during Soft Start	53
Figure 3-17 Output Off Operation during Soft Stop	53
Figure 4-1 Step-control Parameters and Intra-Step Parameters	70
Figure 4-2 Step Behavior	71
Figure 4-3 Stop Phase	74
Figure 4-4 Example of Sequence (CV mode)	75
Figure 4-5 Process Flow in Sequence Step	76
Figure 4-6 Branch Operation/Stop Operation	76
Figure 4-7 Sequence Edit View	89
Figure 4-8 Sequence Control View (Output Off State)	89
Figure 4-9 Sequence Control View (Output On State/Sequence in Execution)	89
Figure 4-10 Sequence Control View (Output On State/Sequence Stopped)	90
Figure 4-11 Simulation Function Steps	93

Figure 4-12 Voltage Dip Simulation Example	95
Figure 4-13 Voltage Change Simulation Example	96
Figure 4-14 Process Flow through Simulation Steps	97
Figure 4-15 Stop Operation	97
Figure 4-16 Simulation Edit View.....	109
Figure 4-17 Simulation Control View (Output Off State, Simulation Stopped)	109
Figure 4-18 Simulation Control View (Output On State, Simulation Running)	109
Figure 4-19 Simulation Control View (Output On State, Simulation Stopped)	110
Figure 4-20 Current Waveform Containing Many Harmonic Components	110
Figure 4-21 Inrush Current Example	112
Figure 4-22 Clipped Sine Wave	114
Figure 4-23 USB Memory Folder Structure	125
Figure 4-24 The Message Window to be Shown Before the Automatic Output-On After the Power-On	153
Figure 4-25 Example of Connecting SHUT DOWN Connector.....	157
Figure 5-1 Component Name (Display Areas on the Screen)	166
Figure 5-2 Menu Composition	169
Figure 7-1 Outline Dimensional Drawing (Rack-mount Adapter [inch])	187
Figure 7-2 Outline Dimensional Drawing (Rack-mount Adapter [mm]).....	187
Figure 7-3 Assembly Diagram (Rack-mount Adapter [inch])	188
Figure 7-4 Assembly Diagram (Rack-mount Adapter [mm])	189
Figure 7-5 Front Grills.....	190
Figure 8-1 Error Message Screen Example	192
Figure 10-1 Maximum system configuration *1	213
Figure 10-2 Range of Ambient Temperature/Humidity	246
Figure 10-3 DP020AGS.....	248

List of Tables

	Page
Table 2-1 List of Content.....	6
Table 2-2 Maximum Power/Current Consumption	10
Table 2-3 Role of Each Unit in a Multi-unit system	15
Table 2-4 Number of Units in System Configuration and Combinations.....	18
Table 3-1 Component Name (Front)	26
Table 3-2 Component Name (Rear).....	27
Table 3-3 Component Name (Control Panel).....	28
Table 3-4 Character String Entry List.....	34
Table 3-5 Shortcut Operations	35
Table 3-6 Master/Slave Settings when 9 Units Connected	38
Table 3-7 Description of the AC/DC Mode	41
Table 3-8 The Description of the Signal Source	41
Table 3-9 List of the Selectable Combinations of the AC/DC Mode and the Signal Source	42
Table 3-10 The Setting Range per Output Range (CV mode)	44
Table 3-11 The Setting Range per Output Range (CC mode)	44
Table 3-12 Output On/Off Phase and Soft Start / Soft Stop Setting Icons.....	54
Table 3-13 Main Measurement Functions.....	55
Table 3-14 Measurement Value Display Format (1P2W Output)	56
Table 3-15 Measurement Value Display Target (Polyphase Output)	58
Table 4-1 Parameters of Sequence Function	72
Table 4-2 Example of Editing Sequence (CV mode)	75
Table 4-3 Simulation Function Parameters	93
Table 4-4 Simulation Function Steps and Settable Step Parameters	94
Table 4-5 Voltage Dip Simulation Edit Example	95
Table 4-6 Voltage Change Simulation Edit Example	96
Table 4-7 Different Output Voltage Settings Depending on Clip Depth Setting Method	114
Table 4-8 Content Saved in Sequence Memory	123
Table 4-9 Content Saved in Simulation Memory.....	124
Table 4-10 Modes in Which Can Turn On Remote Sensing, AGC, and Autocal	129
Table 4-11 Setting Range of DC Offset Adjustment Value (CV Mode)	137
Table 4-12 Setting Range of DC Offset Adjustment Value (CC Mode)	138
Table 4-13 CONTROL I/O Pin Assignment	145
Table 4-14 Step Sync Code	145
Table 4-15 Memory Specification.....	145
Table 4-16 CV/CC Mode, High Impedance Output Off, and Output Relay Control	151
Table 4-17 Setting Items to be Reset	160
Table 5-1 Component Name (Display Areas on the Screen)	166
Table 5-2 Status Icons	167
Table 5-3 Measured Value Display Items	168

Table 5-4 Output Setting Display Items	169
Table 5-5 Menus of the Continuous Function	170
Table 5-6 Menus of the Sequence Function	171
Table 5-7 Menus of the Simulation Function	172
Table 5-8 Menus of the Memory Function	172
Table 5-9 System Menus	173
Table 7-1 System Cable Model Names	186
Table 7-2 Rack-Mount Adapter Model Names	186
Table 7-3 Replacement Air Filter Model Names	190
Table 7-4 Power Cable Model Names	190
Table 8-1 Description of the Error Message Screen	192
Table 8-2 Error Message List.....	194
Table 8-3 Actions When a Failure is Suspected	198

1. Outline

1.1	Overview	2
1.2	Features	2

1.1 Overview

The programmable AC power source DP020AGS is a single-phase 2 kVA AC / 2 kW DC stabilized power source that can flexibly configure boost-up and polyphase system, and can switch between constant voltage output (hereinafter referred to as CV) and constant current output (hereinafter referred to as CC). Like the existing DP-G series, it is equipped with various interfaces such as external control terminals and communication interfaces, and programmable functions such as sequence and power fluctuation tests, enabling testing of various types of electrical equipment.

1.2 Features

■ Flexible system configuration

DP020AGS single-unit output capacity is 2 kVA. DP020AGS multiple units can be connected by system cables to configure boost-up or polyphase systems. Up to two phase masters can be connected. Two boosters can be connected to each phase master. Multi-unit system of up to nine units can be built. The DP020AGS has master and booster functions, allowing flexible expansion or division of the system with a single model.

Note, however, that different models cannot be combined.

■ CC mode

By customizing, the CC mode can be selected with a maximum current of 20 A / 10 A and a maximum output frequency of 550 Hz. AC/DC mode and signal source can be selected. Sequence function is available.

■ High output voltage

Phase voltage of single-phase two-wire can be output up to 350 Vrms, three-phase line voltage up to 600 Vrms, and single-phase three-wire line voltage up to 700 Vrms. The single-phase three-wire DC output can output a maximum of 908 V line-to-line voltage.

■ Sequence function

User can program a sequence to change output voltage, frequency, waveforms and so on with this function, which provides automation of switching continuously a number of testing conditions. This function is also available in CC mode.

■ Various interfaces to address a variety of usage

The interface to use for the remote controlling from a computer or sequencer is equipped. USB, RS232, GPIB, and LAN interface are standard. You can use a contact/TTL signal to turn the output on/off or switch the memory without using a computer. The product also offers the status output for showing the device status and the output which is synchronized with Sequence or Simulation step. With these functions you can achieve various types of systemization and automatization. The AGC function and Autocal function for calibrating the output voltage drop are also provided.

■ Power fluctuation test (=Simulation) function

User can simulate power line abnormalities, such as blackout, voltage rise, voltage drop, abrupt phase change, abrupt frequency change, and so on.

■ Direct recall function

The RECALL key and numeric keypad can be used to directly recall the basic setting memory from No. 0 to No. 9.

■ Variable limiter

This function can limit the effective value and the positive/negative peak value of the output current/voltage where the limiting value is variable. You can set the limiter so that the output is turned off when the limited condition continues for a certain time.

■ Feature-rich measurement function

On the panel the product displays the effective value, peak value, average DC value, and peak-hold value of the output voltage/current. Furthermore, the power factor, crest factor, active/apparent power, and harmonic current are also measured and displayed.

■ Control Software

User can perform the following operations by using Control Software:

- Operations same as those performed on the control panel
 - Data logging (importing the measured values)
 - Editing/transferring/exporting* /performing Sequence
 - Editing/transferring/exporting* /performing Simulation
- *Exporting the data to USB memory allows the data to be set to DP020AGS.

The control software can be downloaded from the support page of our website.

<https://www.nfcorp.co.jp/english/>

■ USB memory support (supported format type: FAT32)

User can write/read the following data to/from a commercial USB memory stick:

- Basic setting
- Sequence
- Simulation

■ Restriction of power usage

The efficiency is improved by about 30 % compared to the linear amplifier method by adopting the switching amplifier method.

■ High impedance output off function

When the high impedance output off function is enabled, the output is switched off in a high impedance state, so that the output can be switched off without discharging the electric charge of the capacitors or batteries connected to the output terminals.

If the high impedance output off function is disabled, the output voltage is set to 0 V before the output is switched off, thereby suppressing voltage surges when the output is switched off.

In CC mode, it is fixed to Disable, the output is switched off after the output current is set to 0 A.

■ Options (partial)*

- System Cable
Connect multi units by this cable to configure a polyphase output system.
- Rack-Mount Adapter
A set of brackets used to mount the product on the EIA or JIS standard compliant rack.
- Power Cable
Cables for the power input.

* These are dedicated options.

2. Preparation before Use

2.1	Check before Use	6
2.2	About Installation Environment	7
2.3	Cautions during Moving and Transportation	8
2.4	Grounding and Power Connections	9
2.5	Output, Sensing, and System Cable Connections	12
2.6	Simple Operation Check	22
2.7	Calibration	23

2.1 Check before Use

■ Check the safety.

To ensure equipment operator's safety, be sure to read the following sections of the instruction manual.

- *Safety Precautions* (Page ii)
- *2.4 Grounding and Power Connections*

■ Check the appearance and contents.

If there is any problem, contact the seller (NF Corporation or our agent) from whom you purchased this product.

● Appearance check

Make sure that there is no damage or dent made during the transportation on the LCD screen, keys, or dial of the control panel, or rear connectors.

● Contents (main unit and accessories) check

The contents are listed in *Table 2-1*. Make sure that all of the main unit and accessories are included.

Table 2-1 List of Content

Content		Quantity
Main unit	Main unit	1
Accessories	DP020AGS Instruction Manual	1
	Ferrite core	1
	Cable tie	1
	Connector for SHUT DOWN	1

■ Download documentation and software.

The following documents and software are available from our website.

[\(https://www.nfcorp.co.jp/english/\)](https://www.nfcorp.co.jp/english/)

Download for remote control of the product.

- Control Software for DP020AGS
- LabVIEW Driver
- Instruction Manual (Remote Control)
- Control Software for DP020AGS Instruction Manual

2.2 About Installation Environment

To use safely and maintain the reliability, take the followings into consideration:

- Install the product where the exhaust heat will not damage surroundings.
 - This product performs forced air cooling using a fan. Keep the front and rear, on which the air inlet and outlet are located, away from the wall at least 50 cm to secure air circulation.
 - This product exhausts the heat from the air outlet on the rear. Do not place heat-sensitive objects around the outlet.
 - If you install the product in a closed narrow room, air conditioning equipment is required. The heat value is 0.4 kW. (Estimated at power input single-phase 200 V, rated output.)
- Install the product on a sturdy place.
 - The floor needs to have enough strength to support the weight of this product. The mass of DP020AGS is approximately 20 kg.
 - Do not install this product on a sloped surface.

■ About arrangement

Stacking arrangement

- Do not stack a total of four or more units.
- The center of gravity becomes high, which poses a risk of falling down.
- This product does not have a structure for supporting a heavy load.



Tandem arrangement

- Placing this product one behind another causes overheating by exhaust heat, which reduces the product's lifespan.



- Do not place the product on its side, back or top.
- Do not place it in front or back of the other (arrangement which makes the unit placed behind inhale the exhaust heat of the other).
- A total of up to three units of only DP020AGS can be stacked.
- When building a multi-unit system by connecting multiple units together, there is no constraint regarding the order in which units are arranged. Arrange them in your convenient order within the range of the length of the System Cable.

■ Other installation location conditions

- Use the product indoors, at altitude up to 2000 m.
- Use the product where the temperature is 0 to +50 degrees Celsius, and the humidity is 5 to 85%RH (the absolute humidity should be 1 to 25 g/m³, without condensation). However, on some specifications, the temperature range limit is more strict.
- Do not install the product in the following places:
 - Place exposed to inflammable gas
→This may pose a risk of explosion. Never install and use the product in such a place.
 - Outdoors, place exposed to direct sunlight, or place near fire or heat source
→This may reduce the performance, or cause failure.
 - Place exposed to briny air
→ This may cause salt damage.
 - Place exposed to corrosive gas or water, or humid place
→This may cause corrode or failure.
 - Place near electromagnetic field source, high-voltage equipment, or power line
→This may cause malfunction.
 - Place of frequent vibration
→This may cause malfunction or failure.
 - Dusty place
→This may cause failure. Especially do not install the product in a place with conductive dust.
- This product may cause interference if used in residential areas. Such use must be avoided unless the user takes special measures to reduce electromagnetic emissions to prevent interference to the reception of radio and television broadcasts.

2.3 Cautions during Moving and Transportation

Follow the instructions below when moving or transporting this product.

- Remove all wirings connected to this product.

WARNING

- Before removing the wiring, be sure to turn off this product to cut the power from the distribution board. Otherwise, an electric shock might occur.
-

- Check before movement and transportation

- Check the weight before moving the product. The mass of DP020AGS is approximately 20 kg.

2.4 Grounding and Power Connections

■ Ensure to ground.

This product uses a line filter. If the product is not grounded, an electric shock might occur.

WARNING

- Ensure to connect the protective conductor terminal of the power input terminal of this product to an earth ground so that ground resistance is 100 Ω or less. If the product is not certainly grounded, an electric shock might occur.
 - To prevent electric shock, ensure that the protective grounding conductor is connected before you connect a cable to the power input terminals L and N.
 - For grounding, use the optional power cable or a power cable of sufficient ampacity for the maximum current consumption (see *Table 2-2*).
-

■ Before connecting the product to power source, check the followings.

WARNING

- The power supply for this product must be taken from the distribution board.
 - Before connecting this product to the distribution board, be sure to cut the power to the distribution board. Otherwise, an electric shock might occur.
 - Route the wire so that the distance between this product and the distribution board switch (breaker) is 3 m or less. If the distance with the distribution board exceeds 3 m, install another switch within 3 m from this product to connect. Use a switch complying with IEC 60947-1 and IEC 60947-3 which can shut the power input from all of L and N. (Protective grounding must not be disconnected.) Mark the switch with a sign indicating that it is a disconnecting device of power input for this product.
 - These are from requirements in IEC 61010-1.
-

CAUTION

- Condensation may form inside the product when the ambient temperature or humidity changes suddenly, for example, after transportation in winter. In such case, leave the product in room temperature enough time to evaporate the condensation, and then connect the product to the power source.
-

■ Check the power source

For safety, use the product in the ranges of input voltage and frequency described below.

Voltage range: Single-phase 100 to 230 V

Frequency range: 50 Hz/60 Hz

2. Preparation before Use

■ About power input terminal

The power input terminal screws are M5.

■ About power cable

Use a cable of sufficient ampacity for the maximum current consumption (see *Table 2-1*). A protective grounding cable should have ampacity higher than or equal to the power cable. For the optional power cable, see 7.4.

Table 2-2 Maximum Power/Current Consumption

Rated output	Maximum power consumption	Maximum current consumption	
		Power supply input Single-phase 90 V	Power supply input Single-phase 170 V
2.0 kVA	2.65 kVA	30 A	16 A

■ Power source connection procedure

Check the current capacity of the distribution board before wiring. The wiring must be performed by a professional engineer.

WARNING

- Before connecting this product to the power source, be sure to cut the power to the distribution board. Otherwise, an electric shock might occur.
-

1. Remove the resin-molded power input terminal cover.

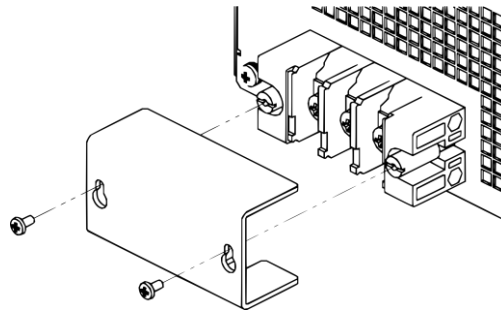

2. Connect the power cable to the power input terminal of this product. Be sure to tighten the screws firmly.

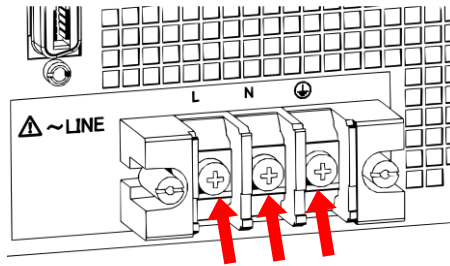

3. Attach the resin-molded power input terminal cover.
4. Ensure that the power switch of this product is turned off, and then connect the power cable to the distribution board.

⚠ WARNING

- Do not use this product when the resin-molded terminal cover is removed. Otherwise, an electric shock might occur.
- Use enough thick cables to prevent touching live conductive parts after attaching the resin-molded terminal cover. If a thin cable is connected, fingers may enter the gap between the resin-molded terminal cover and the cable, resulting in electric shock, therefore attach some additional guards.

⚠ CAUTION

- Be sure to check phases L and N are correctly connected between this product and the distribution board.

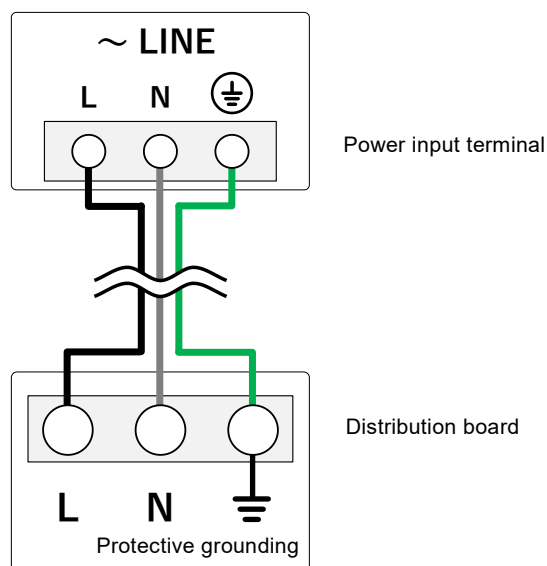

Figure 2-1 Power Input Connection

2.5 Output, Sensing, and System Cable Connections

- Before connecting, check the followings.

⚠ WARNING

- Before touching the output terminal, be sure to turn off the power switch of this product, and cut the power to the distribution board. Otherwise, an electric shock might occur.

⚠ CAUTION

- The output terminals that can be grounded are the Lo terminal. Do not ground the Hi terminal.

- About output terminal

The power output terminal screws are M5.

- About voltage sensing terminal

The conductor diameter of a cable that can be used with the voltage sensing terminal is AWG 24 to AWG 16. Strip approximately 10 mm of the sheath off the cable.

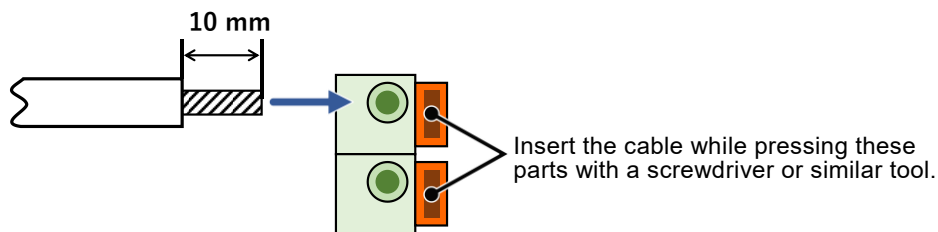

Figure 2-2 Voltage Sensing Terminal

⚠ CAUTION

- Connect the core wires of the cable properly so that they do not touch the unit sheet metal.

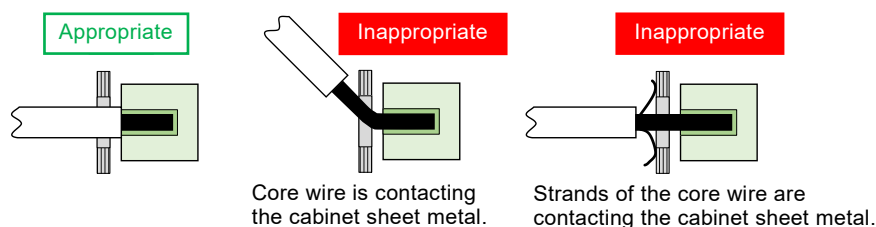

Figure 2-3 Example of Connecting Cable to Voltage Sensing Terminal

2.5.1 Single Output

Connect the output cable. When using the remote sensing function (see 4.11), also connect the sensing cable.

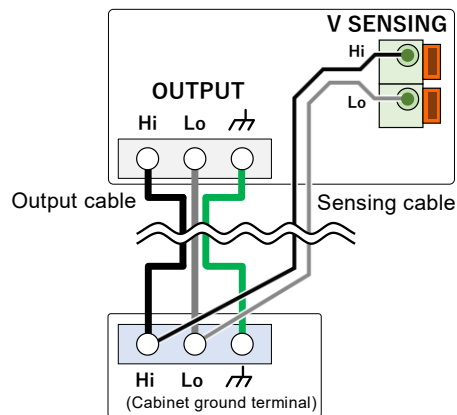
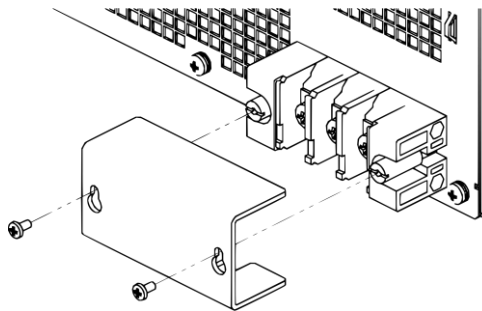

Figure 2-4 Connecting Output and Sensing Cables

■ Connection procedure (output cable)

1. Remove the resin-molded output terminal cover of the output terminal.



2. Connect the output terminal to the load with a cable. Be sure to tighten the screws firmly. If you want to ground the output terminal at one point only, ground the Lo terminal. The Hi terminal should not be grounded. If the load has a ground terminal, connect it to the chassis terminal of the output terminal of this product.

⚠ CAUTION

- The output terminal that can be grounded is the Lo terminals. Do not ground the Hi terminal.
- If you want to ground the output terminal at one point only, ground either one of the output terminal or load terminal.

3. Attach the resin-molded terminal cover.

2. Preparation before Use

⚠ WARNING

- Do not use this product when the resin-molded terminal cover is removed. Otherwise, an electric shock might occur.
 - Use enough thick cables to prevent touching live conductive parts after attaching the resin-molded terminal cover. If a thin cable is connected, fingers may enter the gap between the resin-molded terminal cover and the cable, resulting in electric shock, therefore attach some additional guards.
-

■ Connection procedure (sensing cable)

1. Remove the resin-molded terminal cover of the voltage sensing terminal.
2. Connect the voltage sensing terminal to the load with a cable.
3. Attach the resin-molded terminal cover.

⚠ WARNING

- Do not use this product when the resin-molded terminal cover is removed. Otherwise, an electric shock might occur.
 - Use the cable with an appropriate length of exposed wires to prevent touching live conductive parts. If the exposed wires are too long, an electric shock might occur.
-

Notes

- To prevent the cable from disconnecting from the connector, the cable can be secured to the projection on the underside of the connector with a cable tie or similar.
-

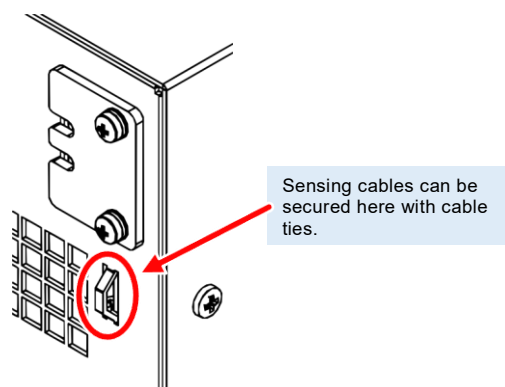

2.5.2 Multi-unit system

You can boost up and build a polyphase system by connecting optional system cables to the SYSTEM connector of this product. Change the role of each unit to one of the roles in *Table 2-3*. The phase master of the L1 phase (= system master) will be the master of the entire system, and other phase masters and boosters will operate as slaves.

Connect the system cables before turning on the power.

Table 2-3 Role of Each Unit in a Multi-unit system

		Description
System master		Master of entire system (master of L1 phase)
Slave	Phase master	Master of the L2 phase or L3 phase that operates with a control signal from the system master
	Booster	Unit for expanding the output capacity of the phase master

----- Notes-----

- For the procedure to set each unit to a master unit or slave unit, see 3.4.

■ System configuration

A polyphase system (single-phase three-wire system or three-phase four-wire system) can be built by installing one or two phase masters for one system master unit. Boost up (parallel operation) of up to two units per phase is possible. In addition, the system can be used as a single-phase two-wire system by outputting with all phases set as the same phase. Therefore, it is possible to configure a system of from 2 kVA to 18 kVA at a maximum with single-phase two-wire output, 4 kVA to 12 kVA at a maximum with single-phase three-wire output, and 6 kVA to 18 kVA at a maximum with three-phase four-wire output. In this document, unless otherwise noted, “1P2W” represents a single-phase two-wire, “1P3W” represents a single-phase three-wire, and “3P4W” represents a three-phase four-wire. For details on the master/slave setting of each unit, see 3.4.2.

Figure 2-5 shows the connection of the SYSTEM connector of each unit for the maximum system configuration.

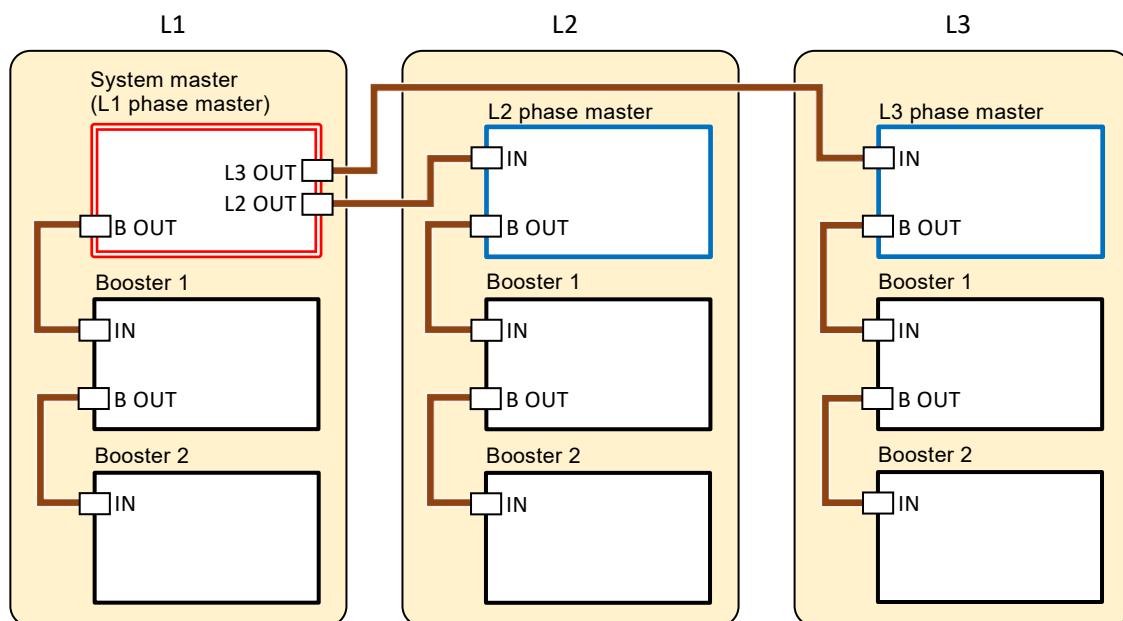

Figure 2-5 Maximum System Configuration



Notes

- Only DP020AGS can be connected.
 - Turn on the power of all units within the set time. (Time set by default: 10 seconds; see 3.4.2.)
 - Make sure that the number of boosters of each phase is the same. If the number differs, an error will occur and output will not be possible.
 - Do not connect anything to a SYSTEM connector that will not be used.
 - In the case of a single-phase three-wire system, the system can be built with the L1 and L2 phases only. Do not connect anything to the L3 OUT connector of the system master.
 - The phase masters and boosters in a multi-unit system are restricted in their operation as follows:
 - Cannot use the communication interface (USB, RS232, GPIB, LAN).
 - Cannot use the external control function and the shutdown function.
 - Cannot use a USB memory. (Except for saving a screenshot)
 - Starts up according to the contents of the Basic Setting Memory No.1 of the system master.
 - Does not accept the control panel key operations except for special cases.
 - Can only display the output measured value of their own unit in the measurement display. The display format of the measured value (3.6.13) follows that of the system master.
-

■ Number of units in configuration

The relationship between the system phase configuration and the number of units in the system configuration is as shown in *Table 2-4*. There are cases in which there are two combinations. Operation is possible with either of the combinations. For example, when building a 1P2W system with three units in the system configuration, you can build it using either combination (a) or (b).

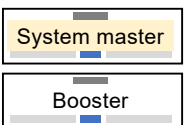
Table 2-4 Number of Units in System Configuration and Combinations

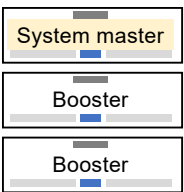
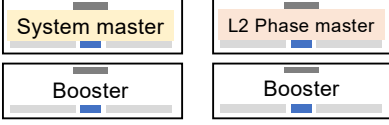
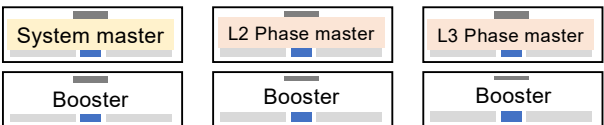
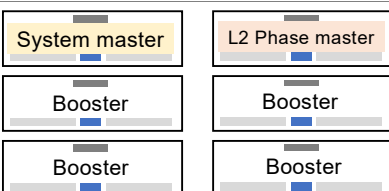
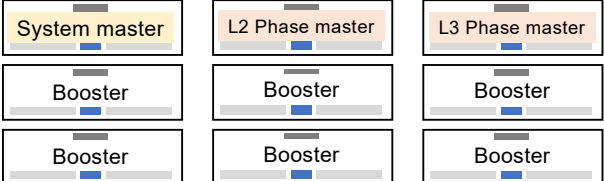
Number of units in entire system configuration	Combination Settable output phase configuration		Output phase configuration
2	(a)		1P2W 1P3W(*)
	(b)		1P2W(*)
3	(a)		1P2W 3P4W(*)
	(b)		1P2W(*)
4	(a)		1P2W 1P3W(*)
5	Configuration is not possible		
6	(a)		1P2W 3P4W(*)
	(b)		1P2W 1P3W(*)
7	Configuration is not possible		
8	Configuration is not possible		
9	(a)		1P2W 3P4W(*)

Note1: At initial startup, the system will start up in the output phase configuration marked with an asterisk (*).

Note2: If the number of units in entire system configuration is 3 (a), 6 (a), and 9 (a), the operation of the L3 phase master and the Booster connected to it is disabled when the output phase configuration is set to 1P3W. This means that the number of units in system configuration is the same as for 2(a), 4(a) and 6(b).

■ Load cable connection (1P2W system)

Connect each of the units to the load with a cable of the same length and thickness. When using a relay terminal block, connect from each of the units to the relay terminal block with a cable of the same length and thickness. For the cable to connect the relay terminal block and load, use a cable of a thickness that supports the flow of the total output current of the units.

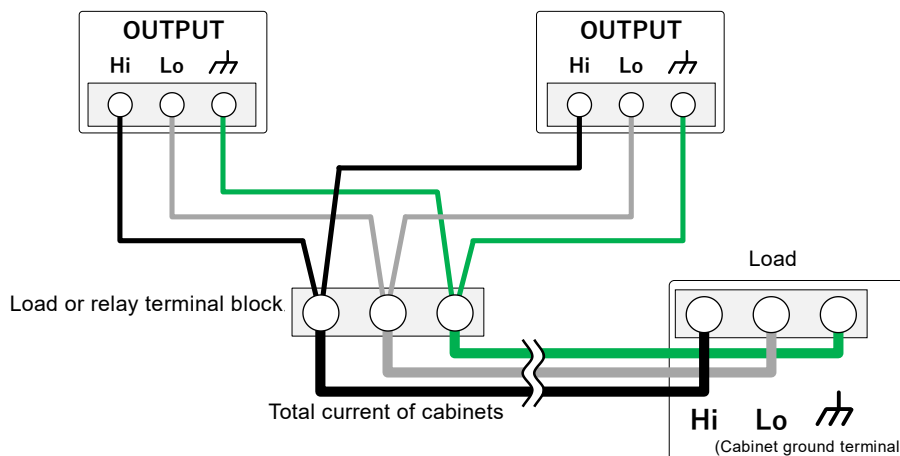

Figure 2-6 Connecting Outputs of Two Units Using 1P2W

■ Load cable connection (polyphase system)

Connect a voltage line to the output Hi terminal of each unit. The neutral line can be connected to the Lo terminal with two methods described below. The neutral line can be grounded. If the load has a ground terminal, connect it to the chassis terminal of each output terminal. Be sure to tighten the screws firmly. When boosting up each phase, each of the OUTPUT terminals in *Figure 2-7*, *Figure 2-8*, and *Figure 2-9* will be an output terminal with a booster connected. For details on booster connections, see *Figure 2-6*.

(a) When connecting the load with the neutral line (1P3W or 3P4W connection)

Connect the neutral point of load with the Lo terminal of each unit using cables with same length and diameter as the voltage line. Alternatively, connect between the Lo terminals of each unit by a cable which is as short as possible and has a diameter equal to or more than that of the voltage line, and then connect one of the Lo terminals with the neutral point of load by a cable with same length and diameter as the voltage line.

(b) When not connecting the load with the neutral line (3P3W connection)

Connect between the Lo terminals of each unit by a cable which is as short and thick as possible (with a diameter equal to or more than that of the voltage line).

Notes

- When operating in CC mode with a polyphase system, connect the neutral point (Lo terminal) to the load. If the neutral point (Lo terminal) is not connected, the product may not operate properly.

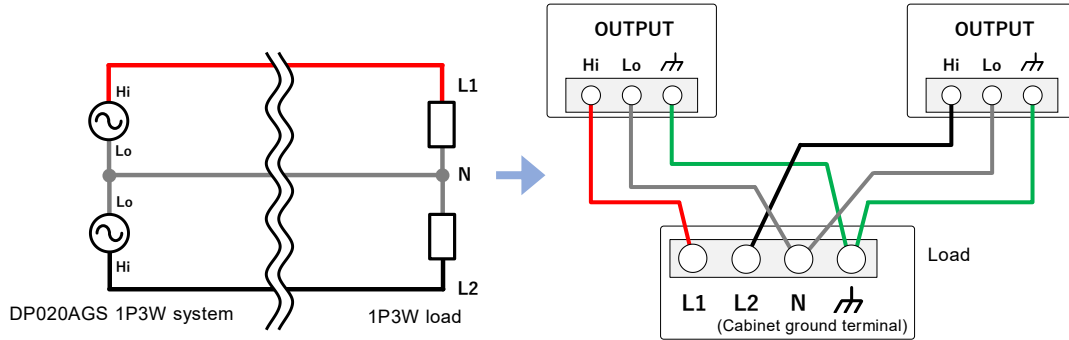

Figure 2-7 1P3W System Connection

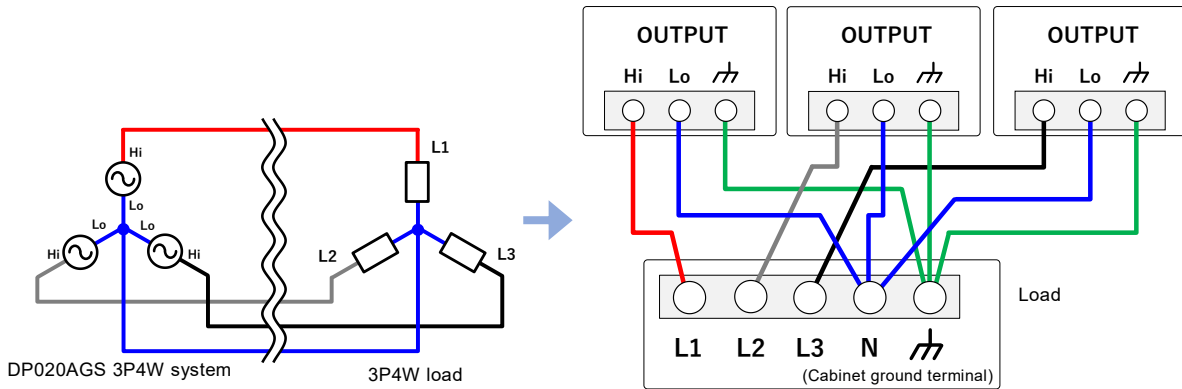

Figure 2-8 3P4W Connection of 3P4W System

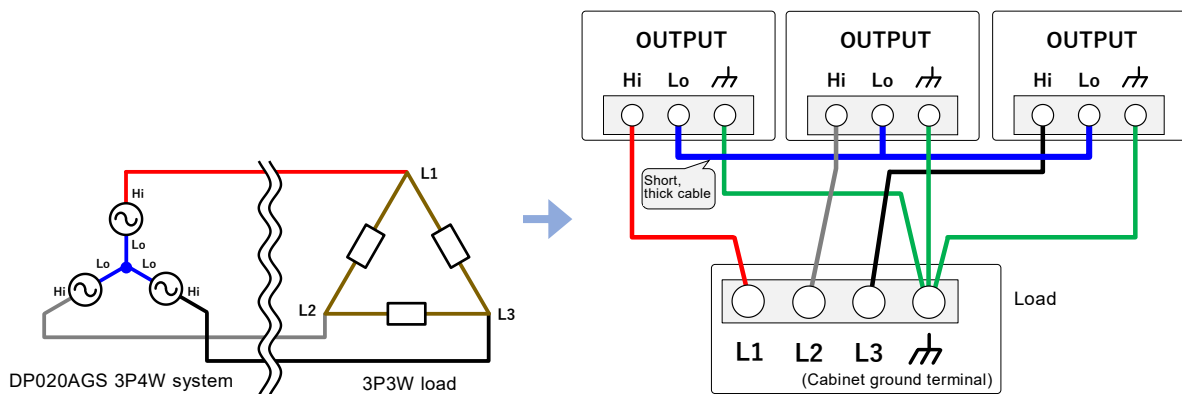
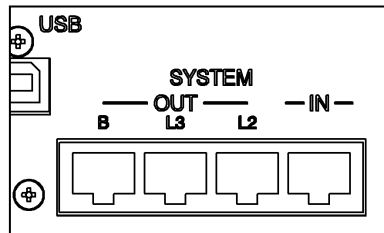

Figure 2-9 3P3W Connection of 3P4W System

■ Connection procedure

1. Connect the system cable to the SYSTEM connector while referring to *Figure 2-5*.



2. Remove the resin-molded output terminal cover of the output terminal of each unit.
3. Connect the output terminal to the load with a cable while referring to *Figure 2-6*, *Figure 2-7*, *Figure 2-8*, and *Figure 2-9*. Connect a voltage line to the Hi terminal of the output terminal of each unit.

⚠ CAUTION

- The terminal that can be grounded is the Lo terminal of each unit. Do not ground the Hi terminal.
- When grounding the Lo terminal of a multi-unit system, ground it at any one of the output terminals or load terminals of any one unit. Do not ground at more than one location.

4. Attach each of the resin-molded output terminal covers. Direct the folded part of the resin-molded terminal cover to the upper side of the product.

⚠ WARNING

- Do not use this product when the resin-molded terminal cover is removed. Otherwise, an electric shock might occur.
- Use enough thick cables to prevent touching live conductive parts after attaching the resin-molded terminal cover. If a thin cable is connected, fingers may enter the gap between the resin-molded terminal cover and the cable, resulting in electric shock, therefore attach some additional guards.

■ Grounding of output terminal

When grounding the Lo terminal of a multi-unit system, ground at the one point of either the output terminal or load terminal of one of the units.

2.6 Simple Operation Check

This section describes how to perform a simple operation check when you purchased a new product, or after storing the product for a long period. This check should be performed without load. For a multi-unit system, remove the system cable, and check the single-phase output for each unit. If you are not satisfied with the results verified at the operation check, please request the repair to us or our agent.

■ Operation procedure

1. Connect the power supply referring to 2.4.
2. Attach the resin-molded output terminal cover without connecting anything to the output terminals or any other terminal/connector. However, if the shutdown input function is enabled, short-circuit the terminals of the SHUT DOWN connector.

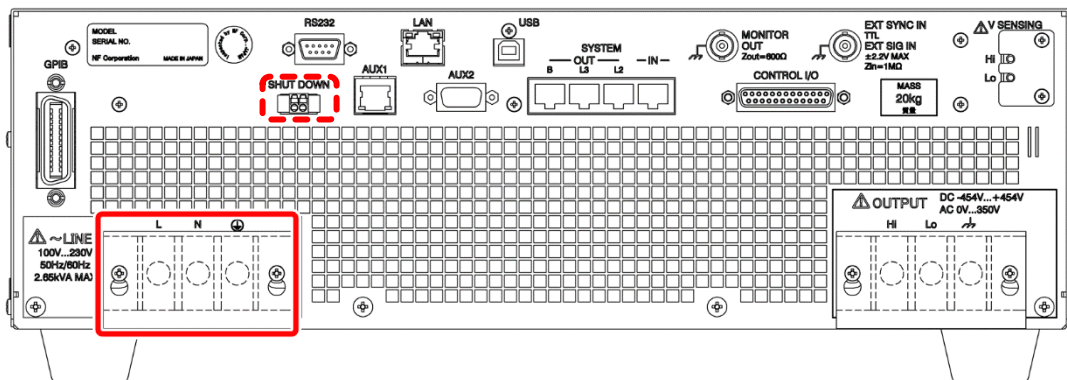

3. Turn on the switch of the distribution board, and then turn on the power switch of this product. Check that all LEDs on the control panel illuminate for several seconds, and then turn off, and that our logo mark appears on the LCD screen (see 3.2.3). After several seconds, the screen transitions to the Self-Test screen automatically. If you press the ENTER key, the startup process resumes.

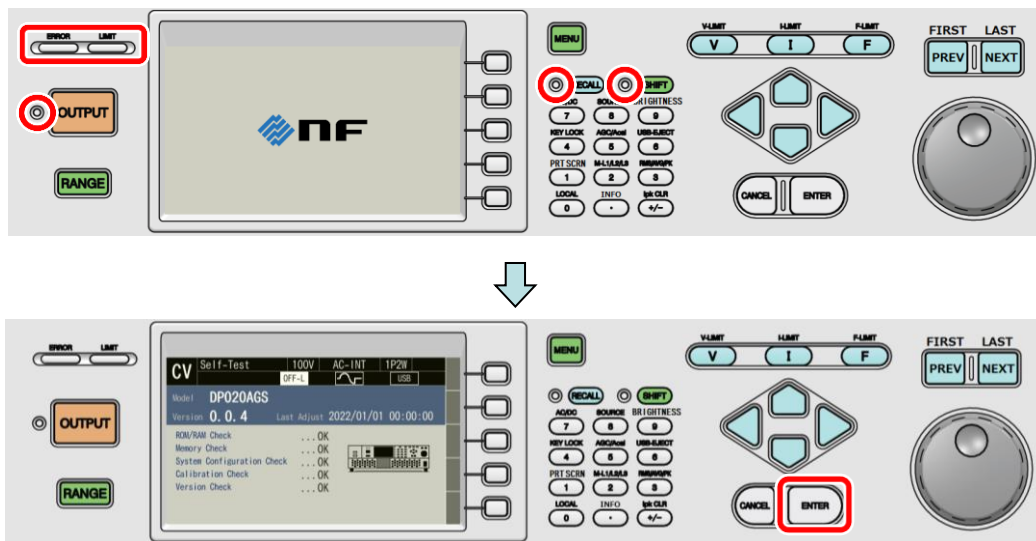

4. Except when you purchased a new product, refer to 4.28 to initialize the product to factory defaults. The product will be reset, and display the Continuous screen automatically.
5. When you purchased a new product, the product will start and then display the Continuous screen automatically.
6. Check that the measured values of CV, 100 V range, AC-INT, V, and I are displayed in RMS, and that the AC voltage (ACV) is set to 0 V.

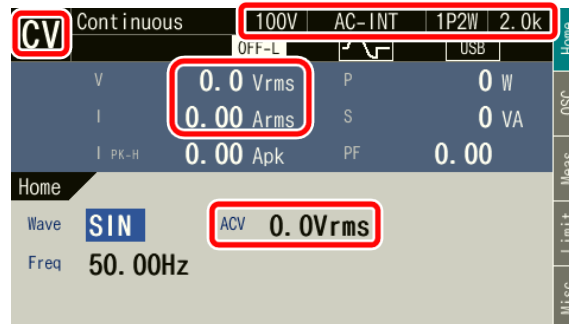

7. Press the OUTPUT key to turn the output on. Press the V key to open the numerical entry box for AC voltage (ACV). Raise the AC voltage setting value gradually by using the MODIFY dial, arrow keys, or numeric keypad, and check that the measured voltage value (V) has become about the same as the setting value.

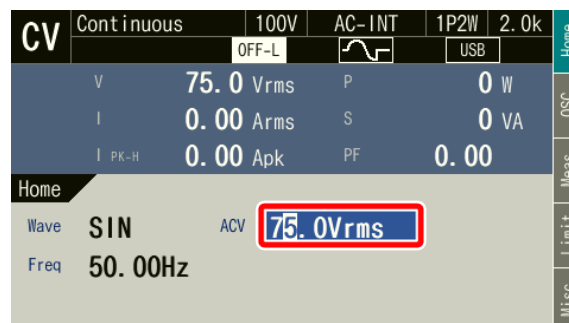

2.7 Calibration

When the product needs calibration, contact us or our agent.

3. Basic Operation

3.1	Component Name.....	26
3.2	Power On/Off.....	29
3.3	Basic Key Operations	31
3.4	Setting Master/Slave	36
3.5	Setting the Output Phase Configuration.....	39
3.6	Using the Continuous Function.....	40
3.7	Setting the CV/CC Mode	60

3.1 Component Name

3.1.1 Front

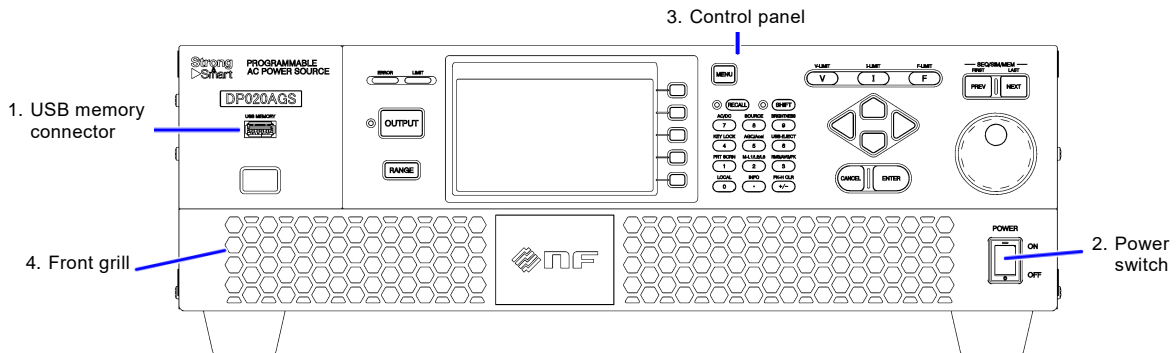

Figure 3-1 Component Name (Front)

Table 3-1 Component Name (Front)

Number	Name	Description	Refer to
1	Control panel	Configures the settings and turns the output on or off. Information such as setting values and measured values is displayed on the LCD screen.	3.1.3
2	USB memory connector	USB memory can be connected.	4.8
3	Front grill	The fresh air inlet. An air filter is attached.	9.2
4	Power switch	Turns the power on/off.	3.2

3.1.2 Rear

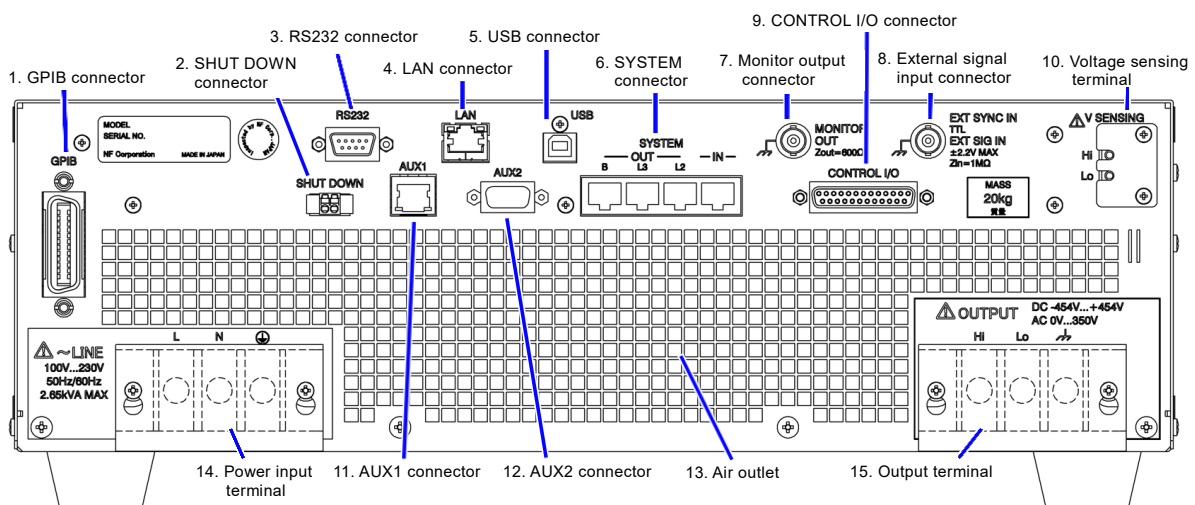

Figure 3-2 Component Name (Rear)

Table 3-2 Component Name (Rear)

Number	Name	Description	Refer to
1	GPIB connector	GPIB communication interface.	6.1.3
2	SHUT DOWN connector	Used to forcibly turn off the output to stop operation by using an external signal (or non-voltage contact).	4.26
3	RS232 connector	RS232 communication interface.	6.1.2
4	LAN connector	LAN communication interface.	6.1.4
5	USB connector	USB communication interface.	6.1.1
6	SYSTEM connector	Used to connect an optional system cable to build a multi-unit system with multiple DP020AGS units.	2.5.2
7	Monitor output connector	Can observe waveforms of the output voltage and output current when connected to a unit such as oscilloscopes.	4.10
8	External signal input connector	Used when controlling the voltage value setting by the external signal (VCA), and when synchronizing the output frequency with the external signal (SYNC).	4.17, 4.19
9	CONTROL I/O connector	Used to control this product externally by logic signal and non voltage contact. You can also get the product state by using the logic signal.	4.18
10	Voltage sensing terminal	Connect to the load end that is located in the distance from the main unit to detect its voltage.	4.11
11	AUX1 connector	This is a spare connector for expansion.	-
12	AUX2 connector	This is a spare connector for expansion.	-
13	Air outlet	Air outlet for exhausting the heat.	2.2
14	Power input terminal	Power input terminal.	2.4
15	Output terminal	Output terminal.	2.5

3.1.3 Control Panel

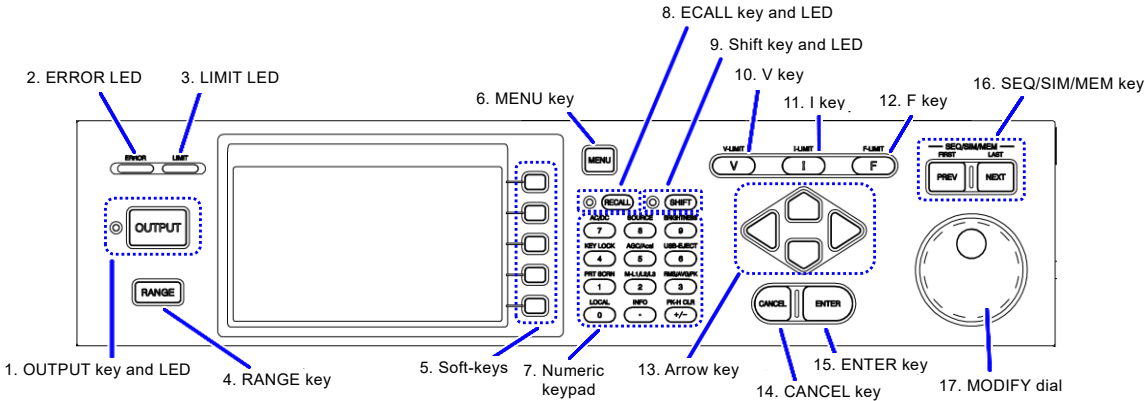

Figure 3-3 Component Name (Control Panel)

Table 3-3 Component Name (Control Panel)

Number	Name	Description	Refer to
1	OUTPUT key OUTPUT LED	Turns the output on or off. The LED illuminates in the output on state.	3.6.11
2	LIMIT LED	Illuminates when any of the limiters activates.	4.1
3	ERROR LED	Illuminates when an error is detected.	8.1
4	RANGE key	Switches between the 100 V and 200 V ranges.	3.6.2
5	Soft-keys	The functions displayed at the right of the LCD screen can be assigned.	5.1
6	MENU key	Displays the root menu.	3.3.1
7	Numeric keypad	Used to enter a value directly.	3.3.5
8	RECALL key RECALL LED	Turns on or off the state that enables the operation to recall from Basic Setting Memory. The LED illuminates when the RECALL state turns on.	4.7.3
9	SHIFT key SHIFT LED	Turns on or off the shift state, which enables Shortcut operations. The LED illuminates when the shift state turns on.	3.3.7
10	V key	Opens the numerical entry box for the output voltage setting when the output mode is CV.	3.6.4, 3.6.5
11	I key	Opens the numerical entry box for the output current when the output mode is CC.	3.6.6, 3.6.7
12	F key	Opens the numerical entry box for the frequency setting.	3.6.8
13	Arrow key	Used to move across the items or incrementing/decrementing the value by one step.	3.3
14	CANCEL key	Returns to the previous state without confirming the selection. Closes the numerical entry box when a value was incremented or decremented using the MODIFY dial or arrow keys.	3.3
15	ENTER key	Confirms the selection.	3.3
16	SEQ/SIM/MEM key	Allows switching steps with the Sequence and Simulation functions. Allows switching the selected memory number in the Memory View.	4.2.6, 4.3.6, 4.7.2
17	MODIFY dial	Used to move across the items or incrementing/decrementing the value by one step.	3.3

3.2 Power On/Off

3.2.1 Before Turning on the Power

This product can output AC 350 V / DC 454 V at a maximum with 1P2W output. With a 1P3W system, it can output AC 700 V at a maximum between the wires. The wrong operations may cause the electric shock or result in malfunction of your load. Please check the following before starting operations.

- When using this product for the first time, we recommend performing the test operation without any connection to the output (= CV, without load) with the instruction manual at your side.
- Double-check the connection to the power supply. Ensure that the cable is appropriate for the current consumption and firmly connected.
- Double-check the connection to the output. Ensure that the cable is appropriate for the output current and firmly connected.

3.2.2 Power On

Press “On” side of the power switch. If you build a multi-unit system, there is no constraint regarding the order in which units are turned on.

3.2.3 Screen Display and Operations at Starting Up

When you power on the unit, all LEDs in the control panel illuminate. The LEDs are lighted off after a while and the following contents are displayed in the order below.

1. The “NF” logo mark is displayed for a few seconds or more than 10 seconds.
2. The self check is performed and the result is displayed. If there was a problem with the result or if the multi-unit system connection has changed, the startup process halts at the Self-Test screen shown in *Figure 3-4*. Check the self check result and press the ENTER key to resume the startup process.

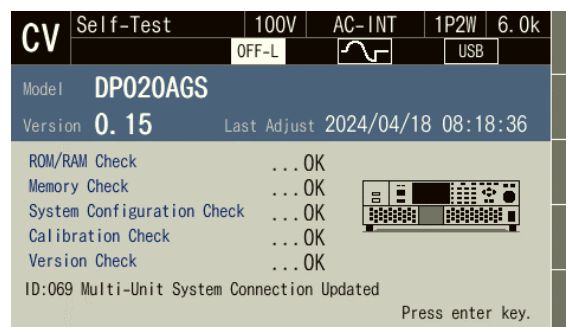

Figure 3-4 Self-Test Screen when Started in a Different System than Before

3. Depending on the output function selection setting at power-on, the Continuous function screen, Sequence function screen, or Simulation function screen is displayed. For detailed information about the output function selection at power-on setting, see 4.2.11 and 4.3.11.

4. If the output function selection is set to the Continuous function and the output-on at power-on setting is on, the output is turned on after the confirmation message to inform that the output is automatically turned on is displayed for about 10 seconds. If you press the ENTER key while this message is displayed, you can cancel the setting of automatic output-on. For detailed information about the output-on at power-on setting, see 4.22.

3.2.4 The Settings Loaded after Startup

For the Continuous function, the output settings are invoked from the Basic Setting Memory No.1 and other settings are loaded from the System Setting Memory. For details, see 4.7 and 10.27.

For the Sequence function and the Simulation function, the factory default settings are loaded for the content of each step.

If the output phase configuration of a multi-unit system has been changed, the settings that are loaded will be in accordance with the output phase configuration,

3.2.5 Checking the Rated Power

On the screen after startup, the rated power icon is displayed in the position shown in *Figure 3-5*. The value in the icon indicates the maximum electric power that can be output. In *Figure 3-5*, the maximum electric power is 2.0 kVA.

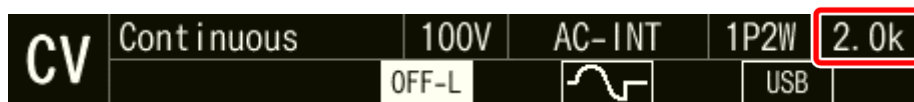

Figure 3-5 The Rated Power Icon

----- Notes -----

- For a multi-unit system, the system total rated power is displayed.

3.2.6 Power off

Disable the output and ensure the OUTPUT LED is off before pressing “OFF” side of the power switch. All screens disappear and all LEDs turn off, then the power input and the output are blocked inside the system. For a multi-unit system, although there is no constraint regarding the order in which units are turned off, a communication error message may appear if the difference in the time between turning off the units is too large. This does not cause any problem.

3.3 Basic Key Operations

3.3.1 Changing the Output Function (Continuous/Sequence/Simulation)

To change the Continuous/Sequence/Simulation function, press the MENU key. This operation displays the root menu shown in *Figure 3-6*.

Five icons are available in the root menu. Move the cursor to the function you want to select by using arrow keys or MODIFY dial. Each icon in upper line represents the Continuous function, Sequence function, and Simulation function from the left. When you press the ENTER key, the screen for the selected function is displayed. You cannot change the function in the output on state. However, you can move to the Memory function screen or System function screen.

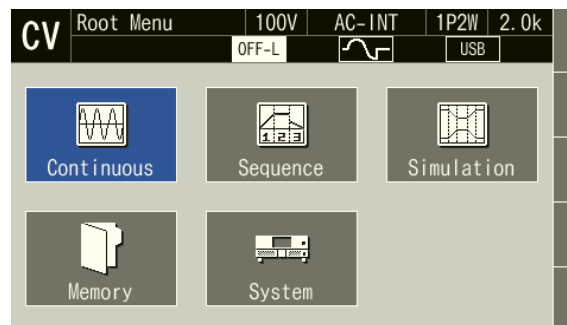

Figure 3-6 The Root Menu

3.3.2 Item Selection

Move the cursor by using arrow keys or MODIFY dial. However, some items cannot be selected depending on the settings. These items are skipped when moving the cursor. If you press the ENTER key, the item under the cursor is selected and run. If the item is a menu, the menu screen, window, or selection box is displayed. If you press the CANCEL key, the menu in the upper hierarchy is displayed without selection or execution of that item.

■ Selection box

If the menu has numbers before its menu items as shown in *Figure 3-7* (selection box), pressing the corresponding number on the numeric keypad also selects and runs the item.



Figure 3-7 The Example of a Selection Box

■ Data list box

When selecting data in the memory, the data list box shown in *Figure 3-8* is displayed. Use the arrow keys, numeric keypad, or Memory No. box to select data in the data list box, and press the ENTER key. This enables the state to enter a value. Press the ENTER key.

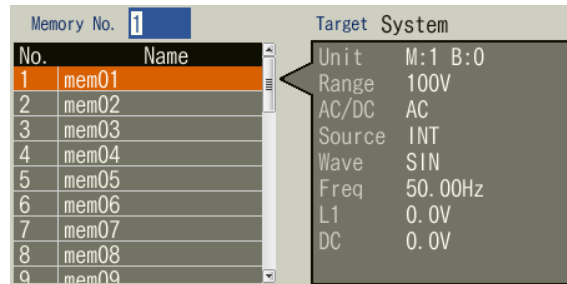

Figure 3-8 The Example of a Data List Box

3.3.3 Using Soft-keys

When soft-key functions are displayed at the right of the LCD screen as shown in *Figure 3-9*, pressing a soft-key performs the function assigned to that key.

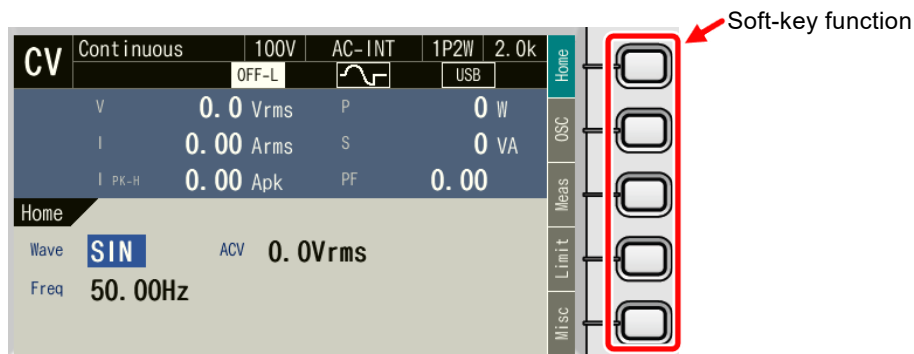

Figure 3-9 Soft-key Function

■ Switching between major items

For a setting function with major items in the setting items, you can switch the major item by moving the cursor with the arrow keys. Switching can also be performed by pressing the soft-key for that function.

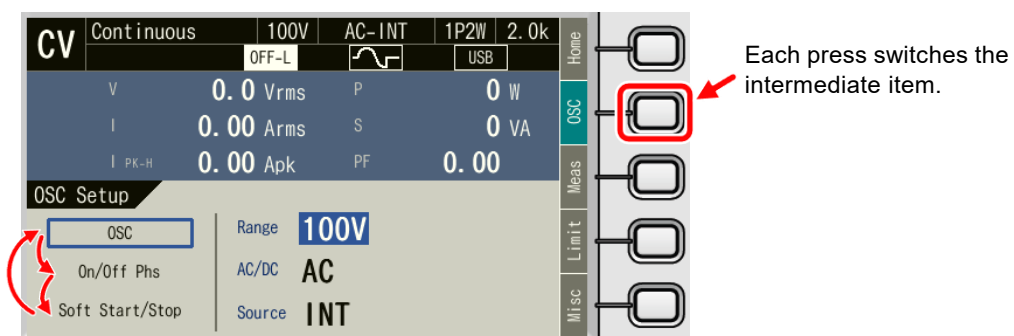

Figure 3-10 Switching Major Items

3.3.4 Closing Windows

■ Window with the [OK]/[Cancel] button

Following two methods are available to close the window with the [OK]/[Cancel] button shown in *Figure 3-11*.

- Move the cursor to the [OK] button or [Cancel] button in the window by using the arrow keys or MODIFY dial, and press the ENTER key.
- Press the CANCEL key. To do so, perform the same operation as you did to select the [Cancel] button.



Figure 3-11 The Example of the Window with the [OK]/[Cancel] Button

3.3.5 Entering Values

■ Input by arrow keys or MODIFY dial

For an item that sets a value, move the cursor to a value and press the ENTER key to switch to the state to change the value as shown in *Figure 3-12*. Move to the desired digit by using the right or left arrow key and increment/decrement the value by using the up or down arrow key or MODIFY dial. During the edit, the value is confirmed every time it is incremented or decremented. For voltage, frequency, and other output, the values are applied even during editing. If you press the ENTER key or CANCEL key, the state to change the value ends.



Figure 3-12 Value Change Screen

■ Enter values directly by using the numeric keypad

For an item required to set values, hover the cursor over a value and enter a new value by using the numeric keypad. A numerical entry box opens as you start entering a value, and the entered value is displayed. Press the ENTER key to confirm the value. The previous values for the voltage or frequency output are held until you press the ENTER key. If you press the CANCEL key, the settings are not changed.

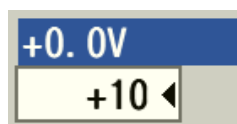

Figure 3-13 The Numerical Entry Box

----- Notes -----

- If you already know the value to set, the direct entry using the numeric keypad will be convenient.
- If you want to increment/decrement the value by one step at one time, use the up and down arrow key.
- If you want to increment/decrement the value by a large amount step by step, use the MODIFY dial.

3.3.6 Entering Strings (Character String Entry Box)

You can change the name of the data when saving it to the internal memory or USB memory. In this case, hover the cursor over the string and press the ENTER key. This enables the state to change the string as shown in *Figure 3-14*.

When you turn the MODIFY dial or press the up or down arrow key, the character at the cursor position is changed in the order of *Table 3-4*. When you press a key in the numeric keypad, the corresponding value or symbol is entered. To move the cursor position, use the right or left arrow key. When you press the ENTER key, the edited string is confirmed.

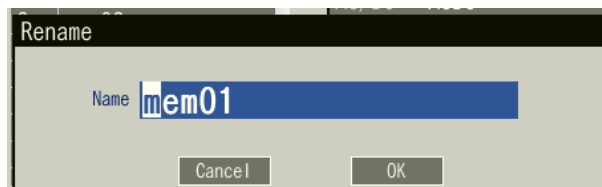

Figure 3-14 String Change Screen

Table 3-4 Character String Entry List

← Turning the MODIFY dial in the counterclockwise direction Pressing the down arrow key	Turning the MODIFY dial in the clockwise direction Pressing the up arrow key →
ABCDEFGHIJKLMNOPQRSTUVWXYZabcdefghijklmnopqrstuvwxyz 0123456789!#\$%&'()+,-.:=@[]^`{}~□	
(Note) □ indicates a space.	

----- Notes -----

- The name of the data which will be saved in the internal memory or USB memory must be 16 characters long at a maximum.

3.3.7 Using Shortcut Operations (SHIFT Key and RECALL key)

When you press the SHIFT key, the SHIFT LED illuminates. In this state (shift state), pressing one of the V, F, I, and any keys in the numeric keypad enables shown in *Table 3-5*.

If you press the SHIFT key once more in the shift state, the SHIFT LED is lighted off and the shift state exits.

When you press the RECALL key, the RECALL LED illuminates. Pressing keys 1 to 9 of the numeric keypad in this state recalls the basic settings of the corresponding number saved in internal memory.

In this instruction manual, pressing key X in the shift state is denoted by “**SHIFT** + X,” and pressing key X in the RECALL state is denoted as “**RECALL** + X.”

Notes

- The shift state or RECALL state is kept until you press the SHIFT key or RECALL key next time. Therefore, continuous Shortcut operations can be performed.
- You do not have to hold down the SHIFT key or RECALL key while you press another key.

Table 3-5 Shortcut Operations

Shortcut	Item	Description	Refer to
SHIFT + V	V-LIMIT	Opens the setting window for the voltage setting range limit in CV mode, and the peak voltage limiter in CC mode.	4.1.3
SHIFT + I	I-LIMIT	Opens the setting window for the peak current limiter in CV mode, and the current setting range limit in CC mode.	4.1.1
SHIFT + F	F-LIMIT	Opens the setting window for the frequency setting range limit.	4.1.3c)
SHIFT + 1	PRTSCRN	Saves a copy of the screen to USB memory.	4.9
SHIFT + 2	M-L1/L2/L3 [†]	Switches the target phase of which the measured value is displayed in the following order: L1, L2, L3, ALL, Line.	3.6.15
SHIFT + 3	RMS/AVG/PK [†]	Switches the display format of the measured value in the following order: RMS, AVG, PK.	3.6.13
SHIFT + 4	KEY LOCK	Enables/Disables the key lock.	4.23
SHIFT + 5	AGC/Acal	Opens the AGC/Autocal set window.	4.12, 4.13
SHIFT + 6	USB-EJECT	Performs the eject operation for removing a USB memory.	4.8
SHIFT + 7	AC/DC	Switches the AC/DC mode in the following order: AC, ACDC, DC.	3.6.1
SHIFT + 8	SOURCE	Switches the signal source in the following order: INT, VCA, SYNC.	
SHIFT + 9	BRIGHTNESS	Opens the brightness setting window for the LCD.	4.25
SHIFT + 0	LOCAL	Exits the Remote state between the device connected to the communication interface and enters the Local state in which the panel operations are accepted.	6.2
SHIFT + .	INFO	The Information window opens.	9.4
SHIFT + +/-	Ipk CLR	Clears the current peak-hold value.	3.6.14
SHIFT + PREV	FIRST	Moves to the first step when changing the step of the sequence or simulation. In addition, moves to the first number when changing the memory number in Memory View.	4.2.6, 4.3.6, 4.7.2
SHIFT + NEXT	LAST	Moves to the last step when changing the step of the sequence or simulation. In addition, moves to the last number when changing the memory number in Memory View.	
RECALL + 0	RECALL	Recalls the factory default basic settings.	4.7.3
RECALL + 1 to 9		Recalls the basic settings of the corresponding number saved in internal memory.	

Note 1: If you change the item presented with [†] symbol using a Shortcut operation, the setting is not saved in the System Setting Memory (see 10.27).

3.4 Setting Master/Slave

Set master or slave for each unit that makes up the multi-unit system.

3.4.1 Opening the Master-Slave Setting Window

When building a multi-unit system, enable the master/slave function.

1. Press the MENU key from the Continuous function to move to the root menu, and then select [System]. The system setting window opens.

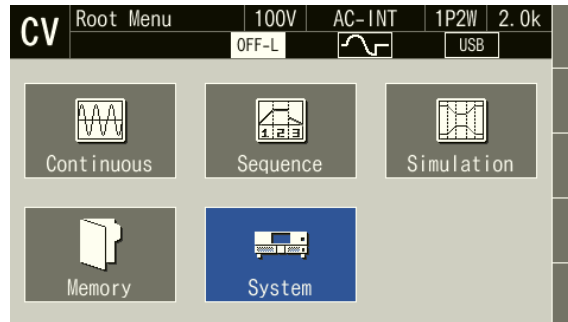

2. Select the [Master-Slave] item.

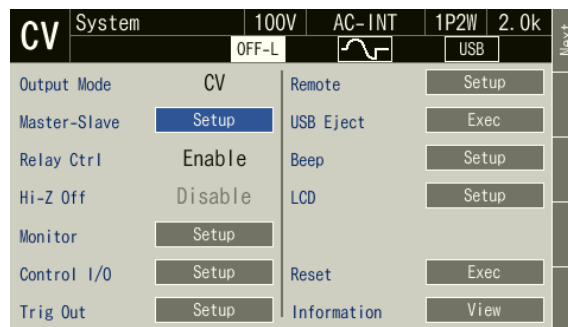

3. The Master-Slave setting window opens. Set the master/slave function in the [Master-Slave] item.

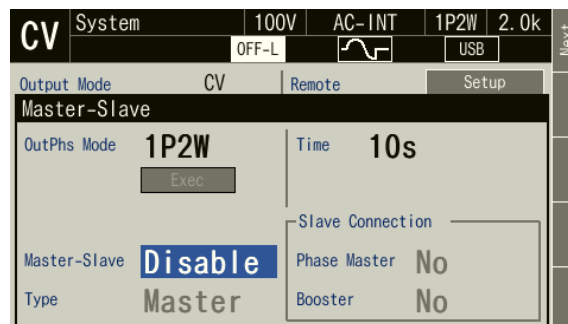

4. First turn the power off and then restart the system to reflect the settings. If you enable the master/slave function, set each item while referring to 3.4.2 and then restart the system.

Notes

- When using a single unit, disable the master/slave function.
- Move to the root menu from the continuous output state. Even if you move to the root menu from the sequence or simulation state, the setting cannot be set.
- For details on connecting the output cables and system cable, see 2.5.2. Be sure to connect the cables before startup. Do not connect and disconnected cables after startup.
- To prevent a contact failure between the system cable and system connector after startup, do not touch the system cable or sheet metal around the system connector.
- Avoid use in a location with a lot of noise. A communication failure may occur between units due to static electricity or noise. If a communication failure has occurred, the protection function is activated and the system is locked. (See 8.1)

3.4.2 Setting Master/Slave

Set the master or slave for each unit that makes up the multi-unit system. When you open the Master/Slave setting window and enable the master/slave function, this item becomes able to be set. Once the setting is complete on all units, first turn the power of all units off and then restart the system to reflect the settings.

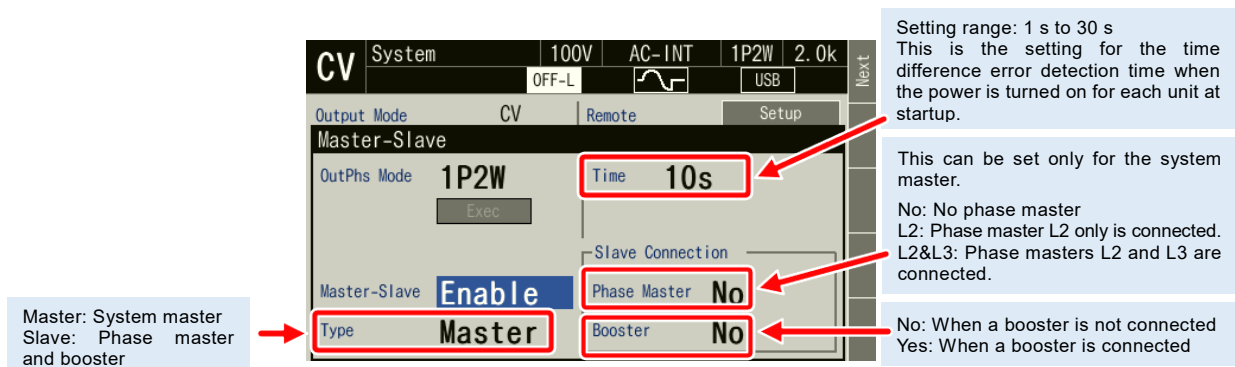

Figure 3-15 Setting Items of Master/Slave Function

Notes

- It takes approximately 3 seconds for the settings to be saved internally. Wait at least 3 seconds before turning the power off after setting completes.
- The output phase configuration at first startup after the master/slave setting will be that marked with an asterisk (*) in Table 2-4 (see 2.5.2).

Table 3-6 Master/Slave Settings when 9 Units Connected

<p>System master</p> <p>Type Master</p> <p>Phase Master L2&L3</p> <p>Booster Yes</p>	<table border="1"> <tr> <th>L1</th> <th>L2</th> <th>L3</th> </tr> <tr> <td>System master (L1 phase master)</td> <td>L2 phase master</td> <td>L3 phase master</td> </tr> <tr> <td>Booster 1</td> <td>Booster 1</td> <td>Booster 1</td> </tr> <tr> <td>Booster 2</td> <td>Booster 2</td> <td>Booster 2</td> </tr> </table>	L1	L2	L3	System master (L1 phase master)	L2 phase master	L3 phase master	Booster 1	Booster 1	Booster 1	Booster 2	Booster 2	Booster 2
L1	L2	L3											
System master (L1 phase master)	L2 phase master	L3 phase master											
Booster 1	Booster 1	Booster 1											
Booster 2	Booster 2	Booster 2											
<p>Phase master and booster 1</p> <p>Type Slave</p> <p>Phase Master No (Fixed)</p> <p>Booster Yes</p>	<table border="1"> <tr> <th>L1</th> <th>L2</th> <th>L3</th> </tr> <tr> <td>System master (L1 phase master)</td> <td>L2 phase master</td> <td>L3 phase master</td> </tr> <tr> <td>Booster 1</td> <td>Booster 1</td> <td>Booster 1</td> </tr> <tr> <td>Booster 2</td> <td>Booster 2</td> <td>Booster 2</td> </tr> </table>	L1	L2	L3	System master (L1 phase master)	L2 phase master	L3 phase master	Booster 1	Booster 1	Booster 1	Booster 2	Booster 2	Booster 2
L1	L2	L3											
System master (L1 phase master)	L2 phase master	L3 phase master											
Booster 1	Booster 1	Booster 1											
Booster 2	Booster 2	Booster 2											
<p>Booster 2</p> <p>Type Slave</p> <p>Phase Master No (Fixed)</p> <p>Booster No</p>	<table border="1"> <tr> <th>L1</th> <th>L2</th> <th>L3</th> </tr> <tr> <td>System master (L1 phase)</td> <td>L2 phase master</td> <td>L3 phase master</td> </tr> <tr> <td>Booster 1</td> <td>Booster 1</td> <td>Booster 1</td> </tr> <tr> <td>Booster 2</td> <td>Booster 2</td> <td>Booster 2</td> </tr> </table>	L1	L2	L3	System master (L1 phase)	L2 phase master	L3 phase master	Booster 1	Booster 1	Booster 1	Booster 2	Booster 2	Booster 2
L1	L2	L3											
System master (L1 phase)	L2 phase master	L3 phase master											
Booster 1	Booster 1	Booster 1											
Booster 2	Booster 2	Booster 2											

3.4.3 When differs from the connection of the system cable

When the master/slave settings differ from the connection of the system cable, the System Locked screen appears due to an error at startup. Press the [M/S] soft-key to open the Master-Slave setting window. Change the settings to match the connection of the system cable and then restart the system.

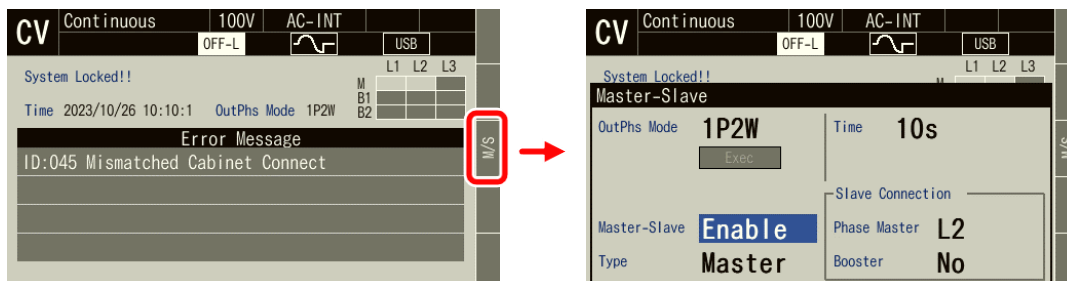

----- Notes -----

- When starting up the system, turn on the power of all units within the time set for the [Time] item.
 - For details on switching the output phase configuration, see 3.5.
-

3.5 Setting the Output Phase Configuration

When building a multi-unit system, set the output phase configuration. For details on connecting the output cables and system cable, see 2.5.2.

■ Setting the output phase configuration

1. Open the Master-Slave setting window and select the output phase configuration in the [OutPhs Mode] item.

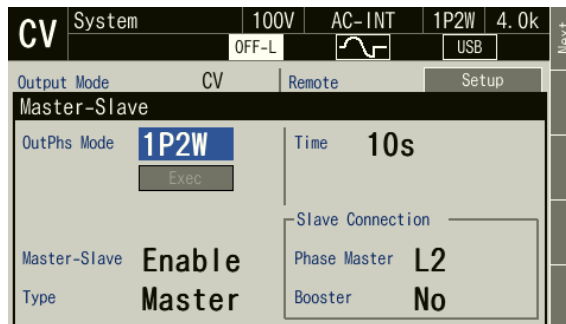

2. Move the cursor to [Exec], then press the ENTER key.

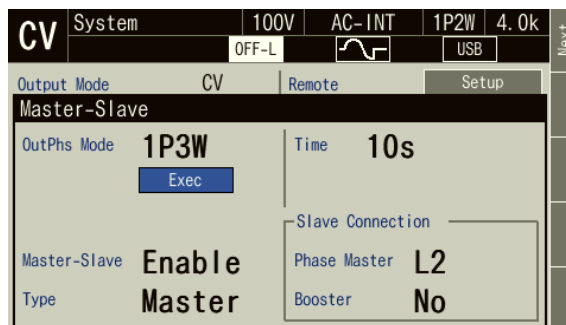

3. When the screen switches to the following screen, turn off the power and change the wiring (output cable and sensing cable).

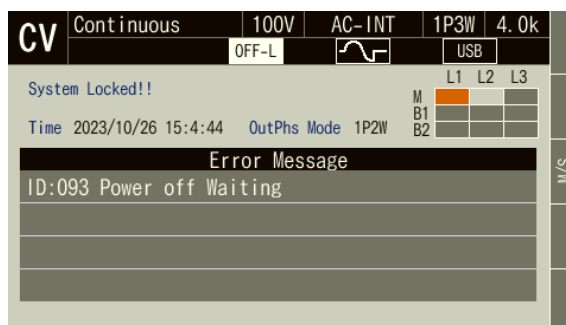

3.6 Using the Continuous Function

3.6.1 Setting the AC/DC Mode and the Signal Source

The description of the AC/DC mode is shown in *Table 3-7*. The description of the signal source is shown in *Table 3-8*. The selectable combinations of the AC/DC mode and the signal source are shown in *Table 3-9*.

----- Notes -----

- If the load is a transformer whose core saturates even with small amount of DC component, select the AC.
 - If you output AC less than 40 Hz, select the ACDC mode. You cannot set the frequency to less than 40 Hz in the AC.
 - In the AC mode, if the output is a waveform that has a long cycle or is dissymmetric in terms of positive and negative (e.g. when the phase is changed rapidly or the different values are set for the positive and negative in the peak current limiter), the waveform may be transformed by the DC component removing function of the AC. If you want to make the output waveform similar to the signal source, select the ACDC.
-

Table 3-7 Description of the AC/DC Mode

AC/DC mode	Description
AC	<p>The signal source and amplification section of this product are AC-coupled, and the DC component is canceled.</p> <p>Only the AC output setting of 40 Hz to 1500 Hz is available.</p> <p>The signal sources that can be combined are INT, VCA, and SYNC.</p>
ACDC	<p>The signal source and amplification section of this product are DC-coupled, and the DC component is also amplified.</p> <p>The AC and DC output settings of 1 Hz to 1500 Hz are available.</p> <p>The signal sources that can be combined are INT and SYNC.</p> <p>In a 3P4W system in CV mode, only the AC output setting is available.</p> <p>Fixed to this mode in the Simulation.</p> <p>Select this mode when you want to amplify a signal including DC, to superimpose DC (DC offset), or output a frequency of 40 Hz or lower. Also select this mode when the DC component temporally occurs, for example, by sudden change of voltage or phase.</p>
DC	<p>The signal source and amplification section of this product are DC-coupled.</p> <p>Only the DC setting is available.</p> <p>The signal sources that can be combined are INT and VCA.</p> <p>For other than 1P2W, the setting is possible only for 1P3W in CV mode.</p>

Table 3-8 The Description of the Signal Source

Signal source	Description
INT	<p>Uses the internal signal source.</p> <p>Sets the output voltage or output current, output waveform, frequency, output on phase, and output off phase by using the panel or the external interface such as USB.</p> <p>Fixed to INT in the Sequence and Simulation.</p>
VCA	<p>Uses the internal signal source.</p> <p>Controls the output voltage or output current setting of the internal signal source with the DC signal which is input to the external input terminal. The output voltage setting cannot be set from external interfaces such as the panel or USB. All conditions except for output voltage setting are same as INT.</p> <p>In the 1P3W system and 3P4W system, the setting is common to all the phases.</p> <p>Cannot be selected in the ACDC.</p>
SYNC	<p>Uses the internal signal source.</p> <p>Synchronizes the frequency of the internal signal source with the signal (EXT) from the external synchronization signal input terminal (also used as the external input terminal) or the power supply input frequency (LINE) of the product. The frequency setting cannot be set from external interfaces such as the panel or USB. All conditions except for output frequency setting are same as INT.</p> <p>Cannot be selected in the DC.</p>

Table 3-9 List of the Selectable Combinations of the AC/DC Mode and the Signal Source

Output phase configuration	AC/DC mode	Signal source		
		INT	VCA	SYNC
1P2W	AC	AC - INT	AC - VCA	AC - SYNC
	ACDC	ACDC - INT	-	ACDC - SYNC
	DC	DC - INT	DC - VCA	-
1P3W	AC	AC - INT	AC - VCA	AC - SYNC
	ACDC *1	ACDC - INT	-	ACDC - SYNC
	DC *1	DC - INT	DC - VCA	-
3P4W	AC	AC - INT	AC - VCA	AC - SYNC
	ACDC *1 *2	ACDC - INT	-	ACDC - SYNC
	DC *1	-	-	-

*1: In CC mode with a polyphase system, only AC can be set.

*2: The DC voltage cannot be set in the ACDC of 3P4W.

■ Operation procedures using soft-keys

1. Press the [Osc] soft-key and select [AC/DC].

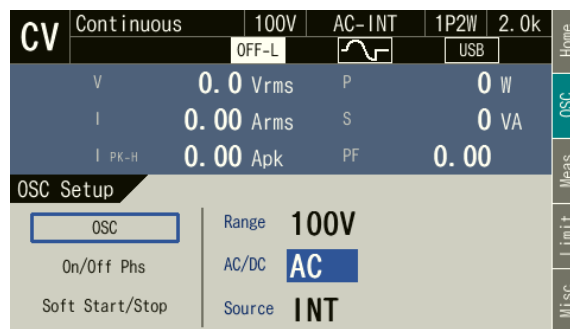

2. In the displayed selection box, select the desired AC/DC mode.

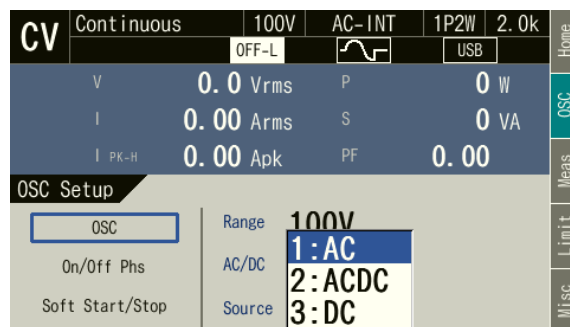

- Press the [Osc] soft-key and select [Source].

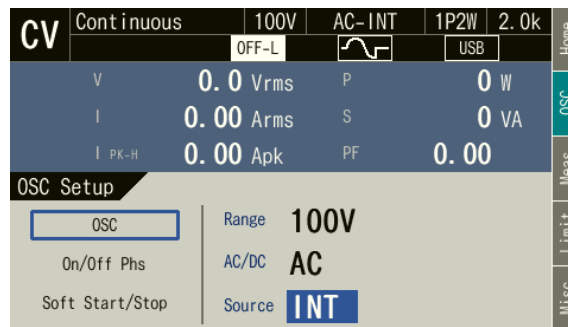

- In the displayed selection box, select the desired signal source.

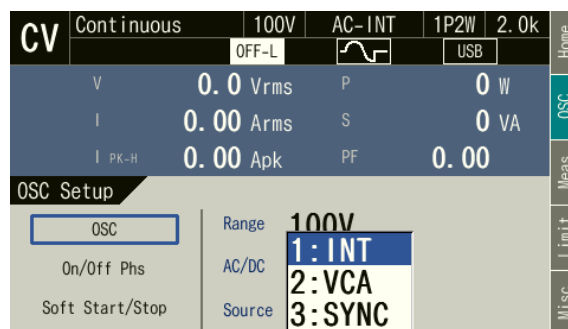

■ Operation procedures by using shortcuts

- SHIFT** + **7** Switching the AC/DC mode

Press the SHIFT key to enter the shift state (the SHIFT LED illuminates). When you press the 7 key of the numeric keypad during the shift state, the AC/DC mode is switched in the following order: AC, ACDC, DC, AC. Some modes may be skipped and cannot be selected depending on the signal source.

- SHIFT** + **8** Switching the signal source

Press the SHIFT key to enter the shift state (the SHIFT LED illuminates). When you press the 8 key of the numeric keypad during the shift state, the signal source is switched in the following order: INT, VCA, SYNC, INT. Some signal sources may be skipped and cannot be selected depending on the AC/DC mode.

3.6.2 Setting the Output Range

In CV mode, you can select the 100 V range or the 200 V range. In CC mode, you can select the 20 A range or 10 A range. *Table 3-10* and *Table 3-11* show the setting range for each range.

----- Notes -----

- You cannot switch the output range in the output on state.
-

Table 3-10 The Setting Range per Output Range (CV mode)

Setting Item	Output phase configuration	AC/DC	Waveform	Setting range		
				100 V range	200 V range	Unit
DC voltage	1P2W	ACDC, DC	-	-227.0 to +227.0	-454.0 to +454.0	V
	1P3W	ACDC, DC		-454.0 to +454.0	-908.0 to +908.0	V
AC voltage (Phase voltage)	1P2W	AC	SIN, CLP	0.0 to 175.0	0.0 to 350.0	Vrms
	1P3W	ACDC		0.0 to 160.0	0.0 to 320.0	Vrms
3P4W	AC			0.0 to 350.0	0.0 to 700.0	Vrms
AC voltage (Line voltage)	1P3W	ACDC		0.0 to 320.0	0.0 to 640.0	Vrms
		AC		0.0 to 303.0	0.0 to 606.0	Vrms
	3P4W	AC		0.0 to 277.2	0.0 to 544.2	Vrms
		ACDC	0.0 to 227.0	0.0 to 454.0	V/V	
External Input Gain				0.0 to 227.0	0.0 to 454.0	V/V
Peak current limiter (positive)				See 10.16		
Peak current limiter (negative)						
RMS current limiter						
Voltage Setting Limit				See 10.18.1		

Table 3-11 The Setting Range per Output Range (CC mode)

Setting Item	Output phase configuration	AC/DC	Waveform	Setting range		
				100 V range	200 V range	Unit
DC current	1P2W	ACDC, DC	-	-20.00 to +20.00	-10.00 to +10.00	A
AC voltage (Line current)	1P2W 1P3W 3P4W	AC, ACDC	SIN	0.00 to 20.00	0.0 to 10.00	Arms
External Input Gain				0.00 to 80.00	0.00 to 40.00	A/V
Peak voltage limiter (positive)				See 10.17		
Peak voltage limiter (negative)						
RMS voltage limiter						
Current setting limit				See 10.18.2		

Note: This is the setting range for a single unit. For the setting range for a multi-unit system, see *10.8.1*, *10.8.2*.

- Operation procedures using soft-keys

1. Press the [Osc] soft-key and select [Range].

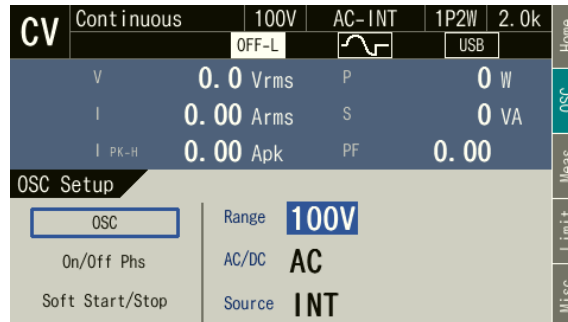

2. In the displayed selection box, select the desired output range.

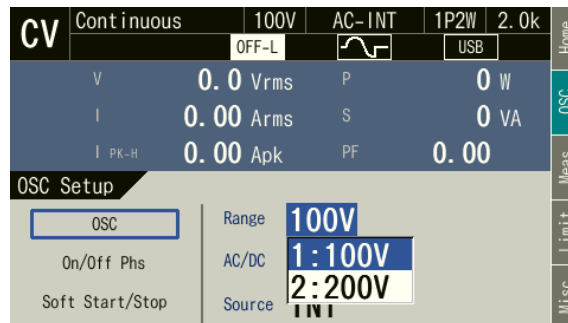

- Operation procedures using the RANGE key

The range is toggled between 100 V range and 200 V range every time you press the RANGE key.

3.6.3 Setting Waveforms

You can select a waveform of the internal signal source from sine wave (SIN) and clipped sine wave (CLP, three types available). See 4.6 for details on the clipped sine wave.

----- Notes -----

- The AC and DC voltage settings (ACV and DCV) are common regardless of the waveform setting.
 - The waveform can be changed in the output on state.
-

■ Operation procedure

1. Select the [Wave] item.

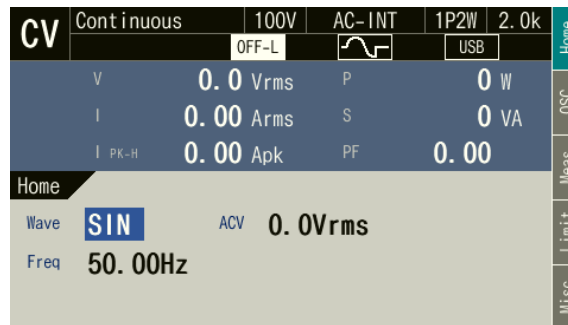

2. In the displayed selection box, select the desired waveform (SIN, CLP, ARB).

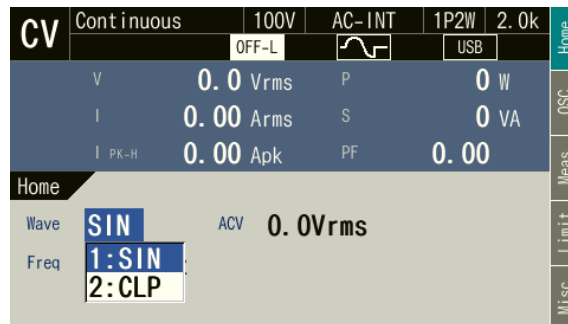

3. If you select CLP, the [Setup] icon () is displayed next to it. When you hover the cursor over the [Setup] icon, the clip ratio or crest factor is displayed. When you press the ENTER key, the setting window opens. In this window, set items.

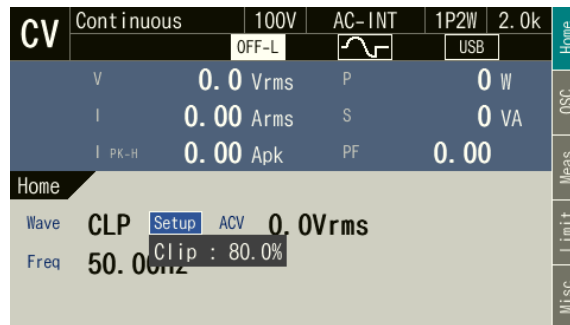

3.6.4 Setting the Output Voltage (Single-phase Output)

Set the AC component and DC component separately for the output voltage of the internal signal source. For the AC component, set the output voltage in the ACV item. For the DC component, set it in the DCV item.

----- Notes -----

- The AC and DC voltage settings (ACV and DCV) are common regardless of the waveform setting.
- In the ACDC, the voltage setting range limit is applied to the additional values of the AC voltage setting (recalculated to a peak value) and the DC voltage setting. For details, see 4.1.3.

■ Operation procedures for setting the AC voltage

Select the [ACV] item and then enter a numeric value. For how to enter values, see 3.3.5.

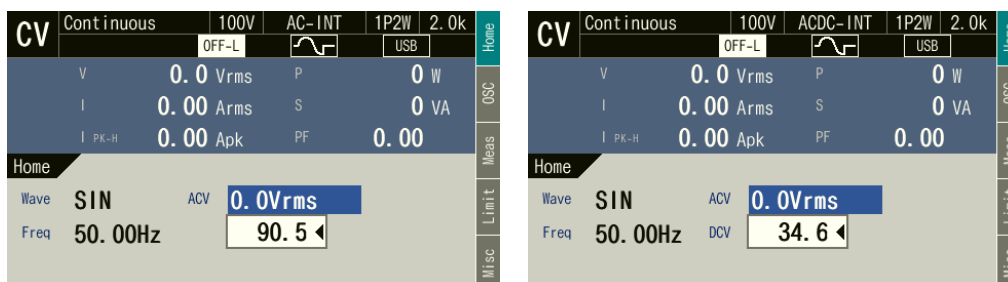

----- Notes -----

- Set the RMS values for the voltages of the sine wave (SIN) and the clipped sine wave (CLP) .

■ Operation procedures for setting the DC voltage

Select the [DCV] item and then enter a numeric value. For how to enter values, see 3.3.5.

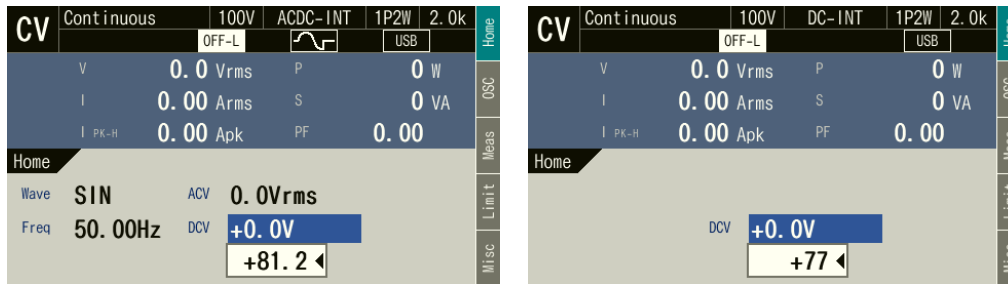

3.6.5 Setting the Output Voltage (Polyphase Output)

This section describes the operations in the balanced mode in a polyphase system. In the balanced mode, the phase voltage and the line voltage are set for all phases at once. To enter the balanced mode, press the [Osc] soft-key and open the phase mode setting window by selecting major item OSC → minor item PhsMode, and then select 1: BAL. For details on the unbalanced mode, see 4.15.

■ Operation procedures for setting the phase voltage

1. Press the [Osc] soft-key to open the OSC Setup screen. Select major item OSC → minor item Target Phs → 1: Phs.

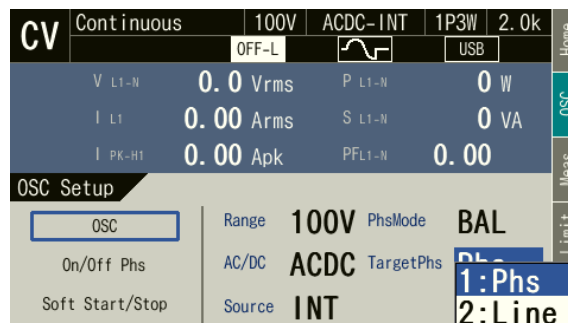

2. Press the [Home] soft-key to open the Home screen. Select the [L1-N] item and then enter a numeric value. For how to enter values, see 3.3.5.

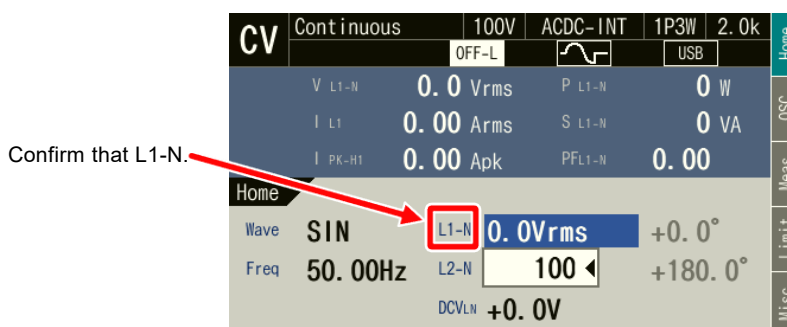

Notes

- With a 1P3W system, the DC components can be set. The value of DCVLN becomes the DC component between L1-N. The value obtained by multiplying DCVLN by -1 becomes the DC component between L2-N. Even in UNBALANCE mode, DCVLN cannot be set separately for L1-N and L2-N.
- With a 3P4W system, the DC components cannot be set.

■ Operation procedures for setting the line voltage

1. Press the [Osc] soft-key to open the OSC Setup screen. Select major item OSC → minor item Target Phs → 2: LINE.

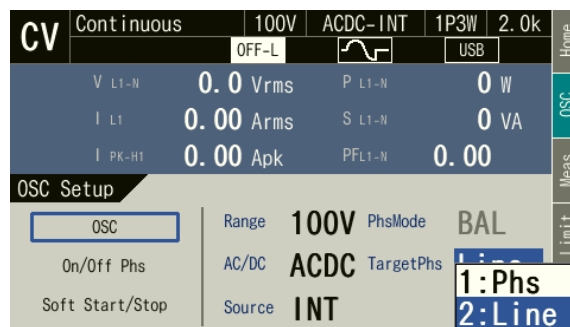

2. Press the [Home] soft-key to open the Home screen. Select the [L1-L2] item and then enter a numeric value. For how to enter values, see 3.3.5.

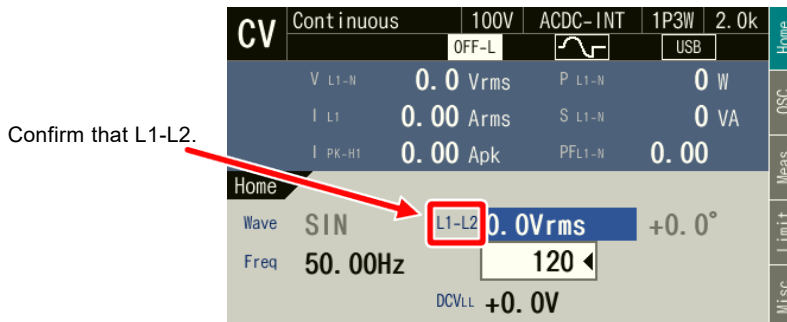

Notes

- The line voltage can be set only for the sine wave in the balanced mode.
- With a 1P3W system, the DC components can be set. The value of DCV_{LL} becomes the DC component between L1-L2.
- With a 3P4W system, the DC components cannot be set.

3.6.6 Setting the Output Current (Single Phase Output)

In CC mode, set the output current. For details on switching between CV mode and CC mode, see 3.7.

----- Notes -----

- In the ACDC, the effective value is calculated from the AC current setting and DC current setting, and the current setting range limit is applied to that value. For details, see 4.1.3.

■ Operation procedures for setting the AC current

Select the [ACI] item and then enter a numeric value. For how to enter values, see 3.3.5.

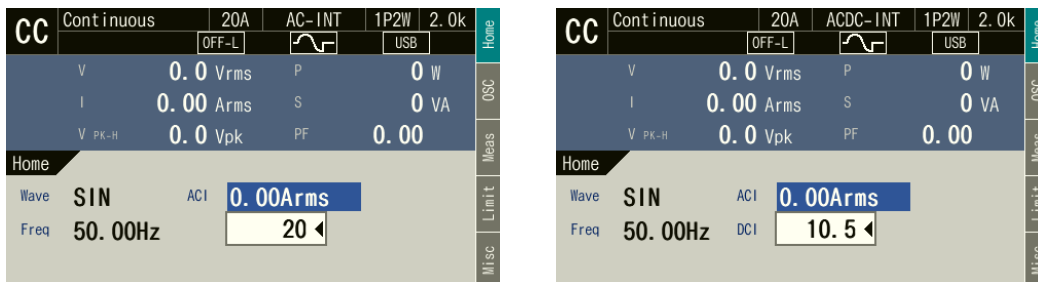

■ Operation procedures for setting the DC current

Select the [DCI] item and then enter a numeric value. For how to enter values, see 3.3.5.

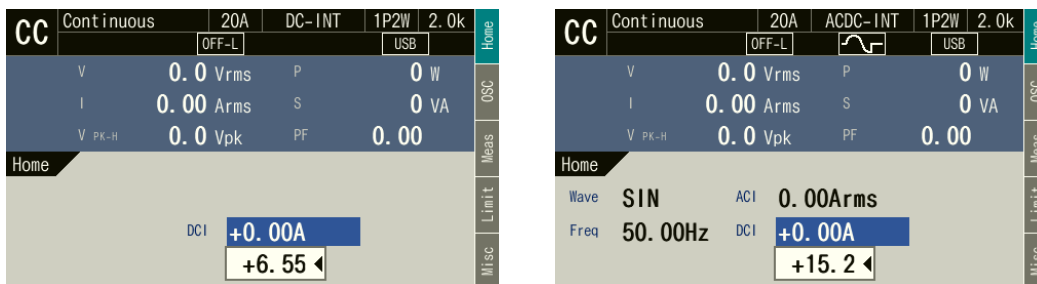

3.6.7 Setting the Output Current (Polyphase Output)

In CC mode, set the output current. This section describes the operations in the balanced mode in a polyphase system. In the balanced mode, the phase current is set for all phases at once. To enter the balanced mode, press the [Osc] soft-key and open the phase mode setting window by selecting major item OSC → minor item PhsMode, and then select [1: BAL]. For details on the unbalanced mode, see 4.15.

■ Operation procedure

Select the [L1] item and then enter a numeric value. For how to enter values, see 3.3.5.

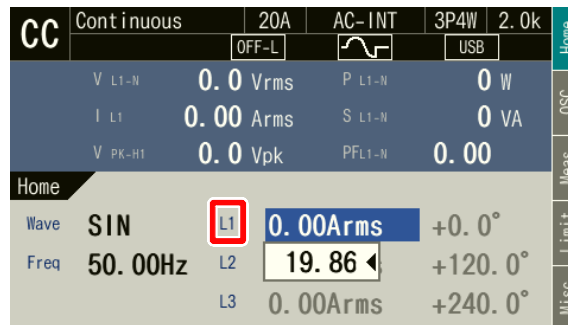

----- Notes -----

- With a polyphase system, setting of DC is not possible.

3.6.8 Setting the Output Frequency

Set the AC component frequency of the internal signal source.

■ Operation procedure

Select the [Freq] item and follow the instructions in 3.3.5 to enter a value.

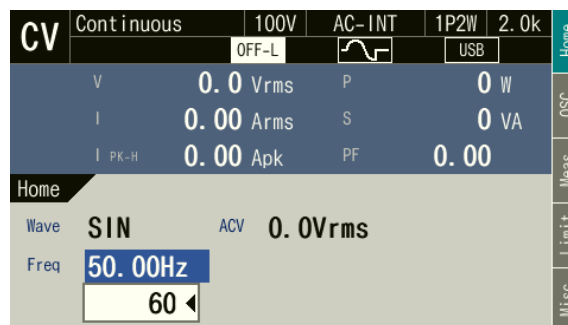

3.6.9 Setting the Output On/Off Phase

Set the phases when the output turns on/off. After the output-on operation, the voltage output is started from the output on phase. After the output off operation, the voltage output is completed when it reaches the output off phase. The output off phase can be disabled. If disabled, the output is turned off immediately after the operation of output off.

■ Operation procedure

1. Press the [Osc] soft-key and select [On/Off Phs]. The output on/off phase setting window opens.

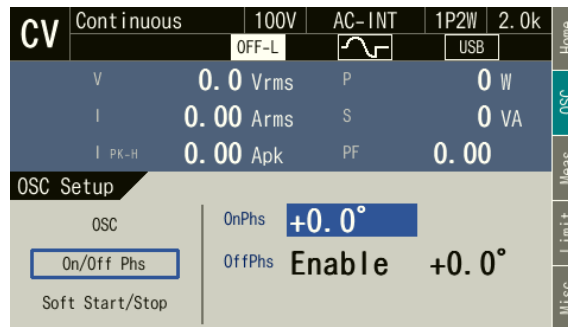

2. Set the on and off phase in the [On Phase] item and [Off Phase] item respectively. If you want to disable the off phase, select [1:Disable].

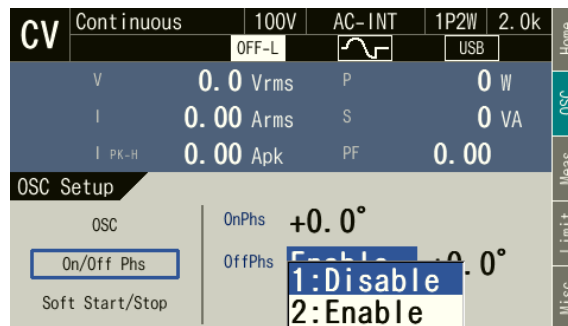

----- Notes -----

- The output on/off phase setting is invalid for the Sequence and the Simulation.
- When soft start is enabled, the output on phase is fixed at +0.0°.
- When soft stop is enabled, the output off phase is disabled.
- If you set output on/off phase or soft start/soft stop, the corresponding icons in *Table 3-12* will light up.

3.6.10 Setting Soft Start and Soft Stop

Soft start is a function to gradually increase the output when the output is turned on. Likewise, soft stop is a function to gradually decrease the output when output is turned off.

When the output off operation is performed during a soft start, a soft stop is implemented over the set time from the output at that point in time. (See *Figure 3-16*.) Also, if the output off operation is performing during a soft stop, output becomes 0 instantly.

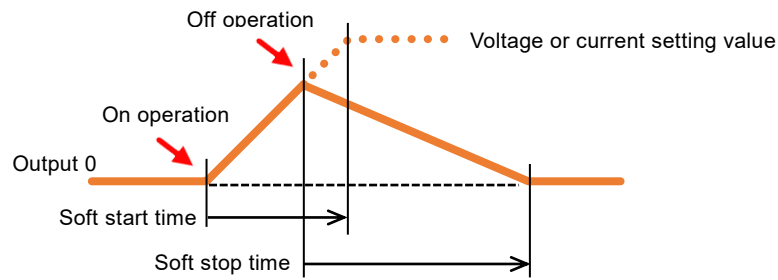

Figure 3-16 Output Off Operation during Soft Start

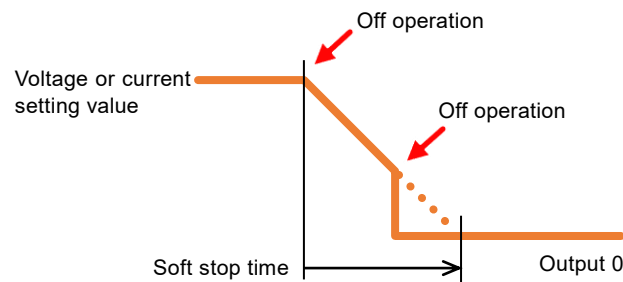

Figure 3-17 Output Off Operation during Soft Stop

----- Notes -----

- If any of the following conditions are met, the soft start and soft stop settings are disabled.
 - When the function of power supply is sequence or simulation
 - When VCA is selected for the signal source
 - AGC and Autocal are on
 - If the following condition is met, only the soft start setting is disabled.
 - When the setting value of the output on phase is a value other than 0°
 - If any of the following conditions are met, only the soft stop setting is disabled.
 - When the output off phase setting is enabled
 - When the high impedance output off function setting is enabled
 - If you set output on/off phase or soft start/soft stop, the corresponding icons in *Table 3-12* will light up.
-

Table 3-12 Output On/Off Phase and Soft Start / Soft Stop Setting Icons

Icon	Output on phase	Output off phase	Soft start	Soft stop
	+0.0° (Factory default setting)	Enabled	Disabled	Disabled
			Enabled	
	Other than +0.0°	Disabled	Disabled	Disabled
				Enabled
	Other than +0.0°	Enabled	Disabled	Disabled
				Enabled
	+0.0° (Factory default setting)	Disabled	Enabled	Disabled
			Disabled	Enabled
			Enabled	Enabled
None			Disabled	Disabled

■ Operation procedure

1. Check that in the state of not meeting the conditions in the notes above.
2. Press the [Osc] soft-key and select [Soft Start] or [Stop]. The output on/off phase setting window opens.

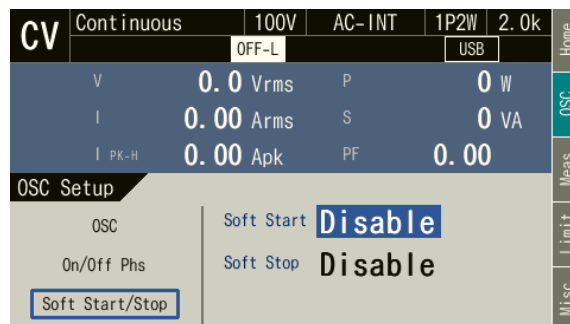

3. Set each of soft start in the [Soft Start] item and soft stop in the [Soft Stop] item.

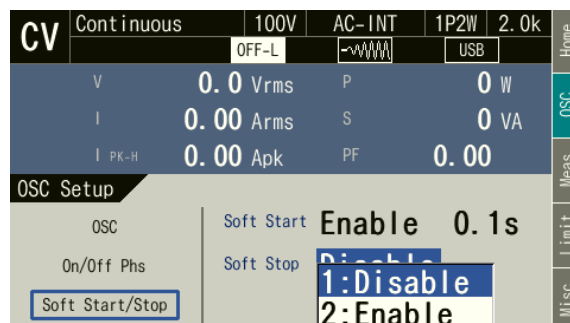

3.6.11 Turning the Output On or Off

Use the OUTPUT key to turn the output on or off. The OUTPUT LED illuminates in the output on state.

When soft stop is enabled, even if the output off operation is performed with the OUTPUT key, output continues for the soft stop period (while decreasing). If the OUTPUT key is pressed once again during the soft stop operation, output turns off instantly.

----- Notes -----

- For how to turn the output on or off rapidly, see 4.20.

3.6.12 Using the Measurement Function

The measured values are displayed in the measured value area (see 5.1). The main measurement functions of this product are shown in *Table 3-13*. For details of the display items of the measured value, see 5.1.2.

Table 3-13 Main Measurement Functions

Item		Description	Unit
V	Output voltage	The output voltage on the output terminal. There are the effective value, average value, maximum value, minimum value, and peak value. For a polyphase system, the output phase is displayed.	Vrms Vavg Vmax Vmin
I	Output current	The output current. There are the effective value, average value, maximum value, minimum value, and peak value. For a polyphase system, the output phase is displayed.	Arms Aavg Amax Amin
V _{PK-H}	Output voltage peak-hold value	The hold value of whichever of the maximum value and minimum value of the output voltage has the largest absolute value.	Vpk
I _{PK-H}	Output current peak-hold value	The hold value of whichever of the maximum value and minimum value of the output current has the largest absolute value.	Apk
P	Active power	The active power provided to the load.	W
S	Apparent power	The apparent power provided to the load.	VA
PF	Power factor	The power factor of the load.	—
CF _I	Crest factor	The crest factor of the output current (peak value/effective value).	—
CF _V	Crest factor	The crest factor of the output voltage (peak value/effective value).	—
Freq	Synchronization frequency	The measured frequency value of the synchronization signal source when the signal source is SYNC.	Hz

3.6.13 Switching the Display Format (RMS/PK/AVG) of the Measured Value

You can switch the display format of the measured value (RMS/PK/AVG) for the output voltage and output current. The items which are displayed in each measuring mode are shown in *Table 3-14*. For a multi-unit system, the display format set in the system master is applied also for the slaves (phase masters and boosters).

Table 3-14 Measurement Value Display Format (1P2W Output)

Measuring mode	Items to be Displayed
RMS	V (effective value), I (effective value), $I_{PK-H}^{(*)}$, P, S, PF
PK	V (maximum and minimum values), I (maximum and minimum values), $I_{PK-H}^{(*)}$, $CF_I^{(*)}$
AVG	V (average value), I (average value), $I_{PK-H}^{(*)}$, P, S, PF

Note : In CC mode, the items marked with (*) are replaced with the following items.

$I_{PK-H} \rightarrow V_{PK-H}$, $CF_I \rightarrow CF_V$

■ Operation procedures using soft-keys

1. Push the [Meas] soft-key. The [Meas Setup] window opens.



2. Select the [Type] item. In the displayed selection box, select the desired measuring mode.

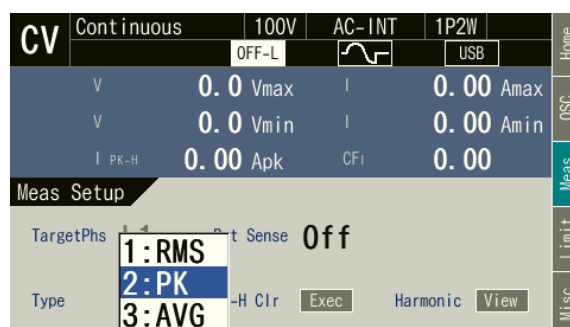

■ Operation procedures by using shortcuts

SHIFT + **3** Switching the display format of the measured values

Press the SHIFT key to enter the shift state (the SHIFT LED illuminates). When you press the 3 key of the numeric keypad during the shift state, the display format is switched in the following order: RMS → AVG → Peak → RMS. Some display formats may be skipped and cannot be selected depending on the CV/CC mode, output phase configuration, and AC/DC mode.

3.6.14 Clearing the Peak-hold Value

The peak-hold value is the maximum absolute value of the measured peak value, which is then updated appending signs and held. The current peak value is held in CV mode, and the voltage peak value in CC mode. This held value can be cleared. After the held value is cleared, it is updated with the value measured after that. The held value is cleared when the power is turned off.

■ Operation procedures using soft-keys

1. Push the [Meas] soft-key. The [Meas Setup] window opens.

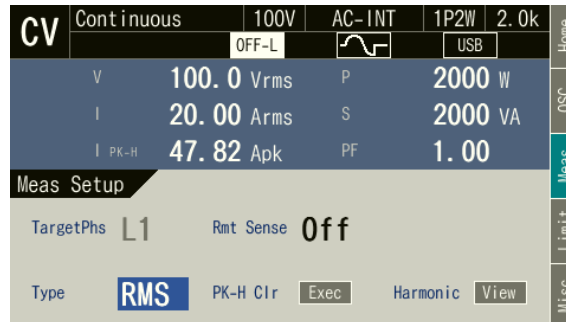

2. Move the cursor to [Exec] of the [PK-H Clr] item and press the ENTER key.

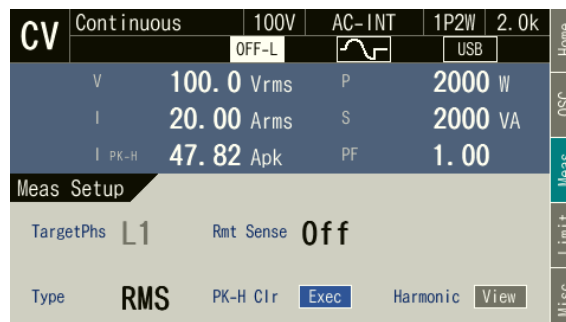

■ Operation procedures by using shortcuts

SHIFT + **+/-** Clear the current peak-hold value

Press the SHIFT key to enter the shift state (the SHIFT LED illuminates). When you press the +/- key in the numeric keypad in the shift state, the output current peak-hold value is cleared.

3.6.15 Switching the Target Phase of which the Measured Values are Displayed (Polyphase Output)

With a polyphase system, you can switch the target phase of which the measured values are displayed. You can also display the phase voltage or line voltage for all phases at once. With display for all phases at once (ALL or Line), the display formats for the measurement values are RMS/PK/AGG, and there are two types of each. There are modes to display both the voltage for all phases and current for all phases (RMS1/PK1/AVG1) and modes to display the voltage for all phases or current for all phases and the output of the entire multi-unit system (RMS2/PK 2). When (RMS2/PK 2), the voltage for all phases is displayed in CV mode and the current for all phases is displayed in CC mode.

Table 3-15 Measurement Value Display Target (Polyphase Output)

Measurement value display target	Measuring mode	Items to be Displayed
L1, L2, L3	RMS AVG PK	Output phase voltage, output current, etc. of each of the L1, L2 and L3 phases (See <i>Table 3-14</i>)
All Line	RMS1	V (effective value), I (effective value), $I_{PK-H}^{(*1)(*2)}$
	RMS2	$V^{(*1)}$ (effective value), $I_{PK-H}^{(*1)}$, P, S
	PK1	V (maximum value), I (maximum value), $I_{PK-H}^{(*1)(*2)}$, $CF_I^{(*1)(*2)}$
	PK2	V (minimum value), I (minimum value), $I_{PK-H}^{(*1)(*2)}$, $CF_I^{(*1)(*2)}$
	AVG1	V (average value), I (average value), $I_{PK-H}^{(*1)}$
	AVG2	$V^{(*1)}$ (average value), $I_{PK-H}^{(*1)}$, P, S

Note 1: In CC mode, the items marked with (*1) are replaced with the following items.

$$I_{PK-H} \rightarrow V_{PK-H}, CF_I \rightarrow CF_V$$

Note 2: When phase-three four-wire output, the items marked with (*2) cannot be displayed.

Note 3: When phase-three four-wire output, AVG1 and AVG2 cannot be selected.

Note 4: The output voltage is phase voltage display when the display target is All, and it is line voltage display when the display target is Line.

Note 5: When display target is Line, PK1 and PK2 cannot be selected.

Note 6: In CC mode, Line cannot be selected for the display target.

----- Notes -----

- Only the system master screen can be switched. A booster displays the output measurement values of that unit, and a phase master displays the measurement values of that phase.
- The line voltage display is not the line voltage value that is measured directly. This is the value that is calculated based on the phase setting value and the measured phase voltage value.
- In the line voltage display, the measured output current value indicates the phase current.
- In the line voltage display, the power factor and crest factor are not displayed.

■ Operation procedures using soft-keys

1. Push the [Meas] soft-key. The [Meas Setup] window opens.

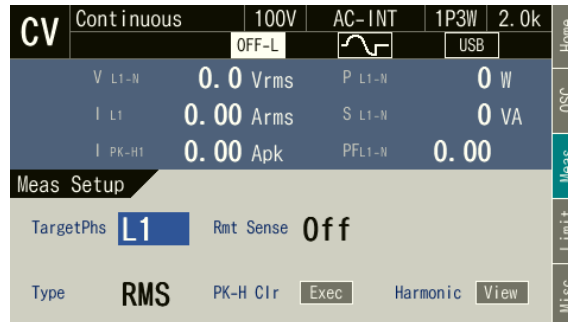

2. In the [Target Phs] item, select the phase of which the measured value is to be displayed.

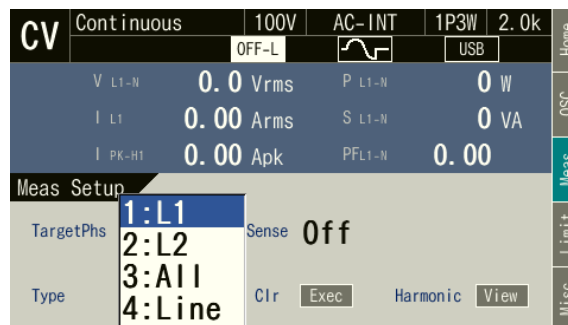

3. Close the window. For how to close the window, see 3.3.4.

■ Operation procedures by using shortcuts

SHIFT + **2** Switching the target phase of which the measured values are displayed

Press the SHIFT key to enter the shift state (the SHIFT LED illuminates). When you press the 2 key in the numeric keypad in the shift state, the phase is switched in the order of L1→L2→All→Line→L1 ... in the 1P3W. In the 3P4W, it is switched in the order of L1→L2→L3→All→Line→L1 ...

3.7 Setting the CV/CC Mode

Through customization, CC mode with a current of 20 A / 10 A at a maximum and output frequency of 550 Hz at a maximum becomes selectable.

■ Setting the CV/CC mode

1. Press the MENU key from the Continuous function to move to the root menu, and then select [System]. The system setting window opens.

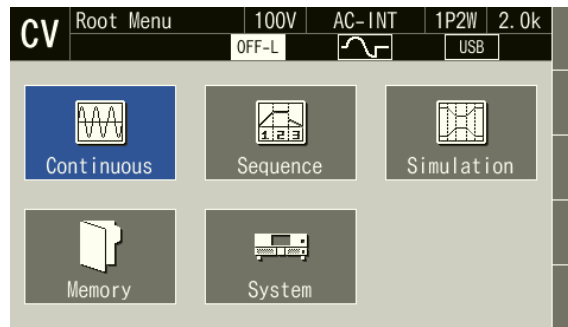

2. In the [Output Mode] item, select [CV] or [CC].

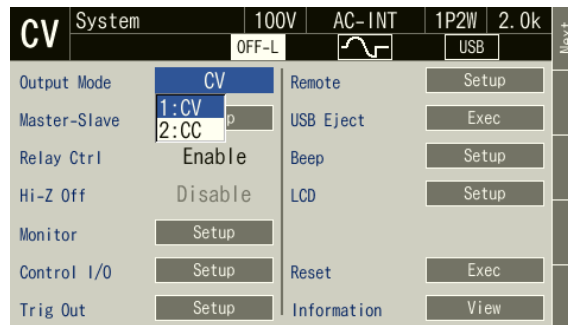

3. The Continuous view with CV/CC switched is redisplayed.

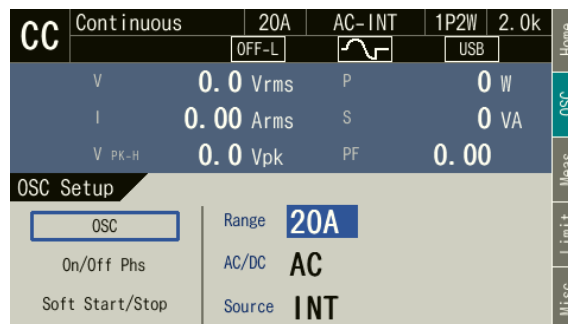

----- Notes -----

- When switching CV/CC with the sequence function, set the function to the Continuous function first before switching.

4. Advanced Operation

4.1	Using Limiter, Setting Limiter.....	62
4.2	Using Sequence Function.....	69
4.3	Using Power Fluctuation Testing (Simulation) Function	92
4.4	Measuring Harmonic Current	110
4.5	Measuring Inrush Current.....	112
4.6	Using Clipped Sine Wave	114
4.7	Using Memory Function	117
4.8	Using USB Memory Function	125
4.9	Saving a Screenshot	126
4.10	Using Monitor Function	127
4.11	Using Remote Sensing Function	129
4.12	Using AGC Function.....	131
4.13	Using Autocal Function	134
4.14	Adjusting DC Offset.....	137
4.15	Using for Unbalanced Polyphase Output	139
4.16	Using as DC Power Supply.....	140
4.17	Setting Voltage or Current using External DC Input Signal	141
4.18	Control Using External Control Function	144
4.19	Synchronizing the Output Frequency with the Power Line or the External Signal	148
4.20	Turning the Output On or Off Rapidly.....	150
4.21	Turning Output Off in the High Impedance State ...	151
4.22	Enabling Automatic Output-On at Power-On.....	152
4.23	Key Lock.....	153
4.24	Beep	154
4.25	Changing the Screen Brightness.....	155
4.26	Using the Shutdown Function.....	157
4.27	Setting the Date and Time	158
4.28	Restoring Initial Settings	160

4.1 Using Limiter, Setting Limiter

4.1.1 Using Peak Limiter

When CV mode, the peak value of output current is limited by the peak current limiter. While the limiter is working, the icon  is displayed and LIMIT LED illuminates. Setting values of limiter are variable, and kept independently for each of 100 V and 200 V ranges.

When CC mode, the peak value of output voltage is limited by the peak voltage limiter. While the limiter is working, the icon  is displayed and LIMIT LED illuminates. Setting values of limiter are variable, and kept independently for each of 20 A and 10 A ranges.

You can choose whether to make the output off or not upon the triggering of the peak limiter. If you choose to set the output off, specify the continuous operation time of limiter until the output off becomes effective. Whether output off is set or not and the time setting are common regardless of the output ranges.

For the default setting range, see 10.16, 10.17.

Notes

- Output current value may be limited by a value that is different from the setting value, depending on the load.
 - For an inductive load, overvoltage protection may be triggered due to the operation of peak current limiter. Overvoltage protection may be avoided by lowering the limiter setting value both for negative and positive values.
 - If the output off after the continuous operation of the limiter for the specified duration is enabled, the setting of output-off phase is ignored.
 - In the case that the peak current limiter operates when the setting value of the peak current limiter is set as asymmetry between positive and negative in the AC, the DC component is generated in the output. Although the function to remove the DC component of the output works in the AC, when the peak current limiter operates intermittently, the DC component may not be removed sufficiently, or the output waveform may be modified.
 - In a multi-unit system, limiter setting values are per phase.
 - In a polyphase system, peak limiter settings are common to all phases.
 - The limiter setting value is retained for each of the CV and CC modes and each of output phase configurations.
-

■ Operation procedure

1. Push [Limit] soft-key to select PK Limiter. Opens the peak limiter set window. The operation can also be performed with shortcut keys.

In CV mode, press **SHIFT** + **I** to open the peak current limiter set window.

In CC mode, press **SHIFT** + **V** to open the peak voltage limiter set window.

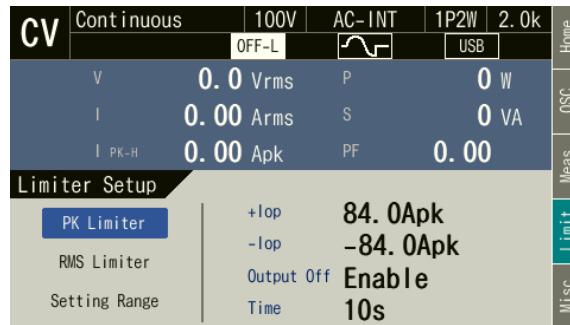

Note: The view is when in CV mode.

2. In CV mode, set the peak current limiter values of positive/negative in the [+Iop]/[-Iop] item.
In CC mode, set the peak voltage limiter values of positive/negative in the [+Vop]/[-Vop] item.

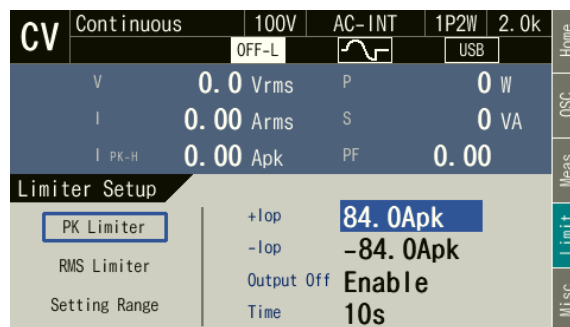

Note: The view is when in CV mode.

3. Set the [Output OFF] item as [Enable] or [Disable]. When setting to [Enable], also set the time from the start of limiter operation to the output off.

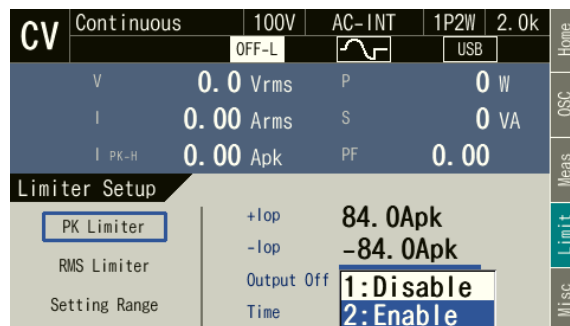

Note: The view is when in CV mode.

4.1.2 Using RMS Limiter

In CV mode, the effective value of output current is limited by the RMS current limiter. While the limiter is working, the icon  is displayed and LIMIT LED illuminates. Setting values of limiter are variable, and kept independently for each of 100 V and 200 V ranges.

In CC mode, the effective value of output current is limited by the RMS voltage limiter. While the limiter is working, the icon  is displayed and LIMIT LED illuminates. Setting values of limiter are variable, and kept independently for each of 20 A and 10 A ranges.

You can choose whether to make the output off or not upon the triggering of the RMS limiter. If you choose to set the output off, specify the continuous operation time of limiter until the output off becomes effective. Whether output off is set or not and the time setting are common regardless of the output ranges.

For the default setting range, see 10.16, 10.17.

Notes

- It will take time from the limiter starting operation to the output current or output voltage being restricted sufficiently, because the RMS limiter needs to calculate the effective value. If you want to limit the output at a faster speed, use the peak limiter. For peak limiter, see 4.1.1.
 - If the output off after the continuous operation of the limiter for the specified duration is enabled, the setting of output-off phase is ignored.
 - In a multi-unit system, limiter setting values are per phase.
 - When the output phase configuration is polyphase, peak current limiter settings are common to all phases.
 - The limiter setting value is retained for each of the CV and CC modes and each of output phase configurations.
-

CAUTION

- In CV mode, for loads with very low impedance (e.g. output short circuit), the RMS current limiter cannot sufficiently limit the output current and may exceed the rated current. Use within the rated current range by checking the current measured value and using the peak current limiter together etc.
-

■ Operation procedure

1. Push [Limit] soft-key to select RMS Limiter. Opens the RMS limiter set window. The operation can also be performed with shortcut keys.

In CV mode, press **SHIFT** + **I** to open the RMS current limiter set window.

In CC mode, press **SHIFT** + **V** to open the RMS voltage limiter set window.

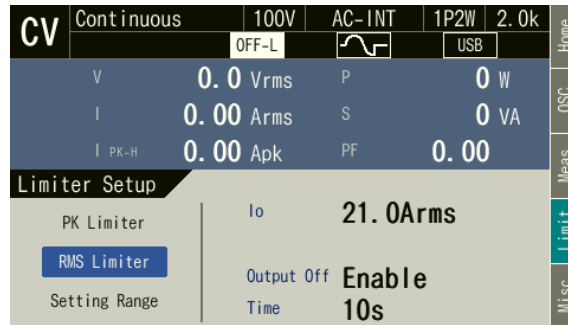

2. Set the value of RMS current limiter in [Io] item.
Set the value of RMS voltage limiter in [Vo] item.

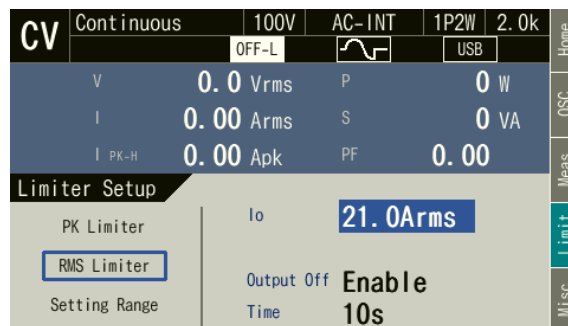

3. Set the [Output Off] item as [Enable] or [Disable]. When setting to [Enable], also set the time from the start of limiter operation to the output off.

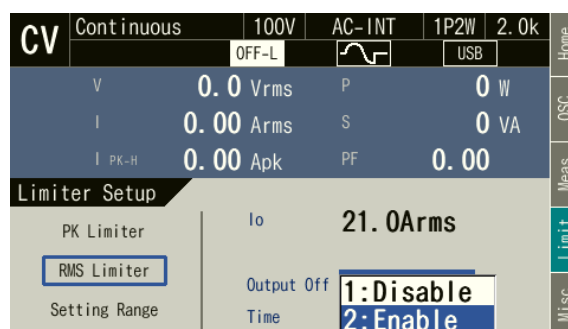

4.1.3 Using Setting Range Limit

You can limit the ranges of output setting values (output voltage in CV mode or output current in CC mode and frequency). A setting range limit is useful for the prevention of an excessive output when the output setting value is rapidly increased or decreased with the MODIFY dial.

a) Voltage setting range limit (CV mode)

For the Continuous function, when the signal source is INT or SYNC, the range of the output voltage setting value to the internal signal source can be limited. Even if trying to set a voltage that exceeds the limit, the setting value is restricted to the limiting value. This can prevent mis-setting when you do not want to set values outside the range.

As for the voltage setting range limiting values, each value is kept independently for the following settings for 100 V and 200 V ranges respectively: AC, ACDC, and DC.

In a multi-unit system, the setting of the voltage setting range limit is a setting per phase, and is common for all phases. When the line voltage setting (effective value setting) is selected in CV mode, the setting of the voltage setting range limit is converted into the effective value setting of the phase voltage according to the following formula and kept as the effective value of the phase voltage in this product.

Balanced three-phase output:

$$\text{Phase voltage} = \frac{1}{\sqrt{3}} \times \text{Line voltage}$$

Balanced single-phase output:

$$\text{Phase voltage} = \frac{1}{2} \times \text{Line voltage}$$

The limiting value should be set using the effective value or the positive and negative peak value. The effective value can be used only when in the AC. When the output phase configuration of a multi-unit system is polyphase, the limiting value can be set using the line voltage when in the CV, AC, and balanced modes, and the output voltage setting is a line setting. In other cases, set using the positive and negative peak values of phase voltage.

For the default setting range, see **10.18.1**.

----- Notes -----

- In ACDC, set the voltage setting range limit setting using the positive and negative peak values of the phase voltage regardless of the settings of the waveform, balanced/unbalanced mode, phase voltage/line voltage.
- In ACDC, the limit is applied to the additional values of the AC setting (recalculated to a peak value) and the DC setting.
- The Sequence and the Simulation function do not include the setting range limiting function.
- A setting range limit that does not include an output voltage or output current already set cannot be set.
- In a polyphase system, the setting range limit is common to all phases.

b) Current setting range limit (CC mode)

For the Continuous function, when the signal source is INT or SYNC, the range of the output current setting value to the internal signal source can be limited. Even if trying to set a current that exceeds the limit, the setting value is restricted to the limiting value. This can prevent mis-setting when you do not want to set values outside the range.

As for the setting range limiting values, each value is kept independently for the following settings for 20 A and 10 A ranges respectively: AC, ACDC, and DC.

In a multi-unit system, the setting of the setting range limit is a setting per phase, and is common for all phases.

The limiting value should be set using the effective value or the positive and negative peak value. The effective value can be used only when in AC or ACDC. In DC, set using the positive and negative peak values of phase current.

In ACDC, the effective value is calculated according to the following formula from the AC setting and DC setting, and the limit is applied to that value.

$$\text{RMS} = \sqrt{(\text{AC setting value})^2 + (\text{DC setting value})^2}$$

For the default setting range, see *10.18.2*.

----- Notes -----

- The Sequence and the Simulation function do not include the setting range limiting function.
- A setting range limit that does not include an output voltage or output current already set cannot be set.
- In a polyphase system, the setting range limit is common to all phases.

4. Advanced Operation

c) Frequency setting range limit

You can limit the range of the frequency setting value for the internal signal source by using the frequency setting range limit. Even if trying to set a frequency that exceeds the limit, the setting value is restricted to the limiting value. This can prevent mis-setting when you do not want to set values outside the range.

The frequency setting range limiting value is common to both output ranges.

For the default setting range, see *10.18.3*.

Notes

- The frequency setting range limit is useful for the prevention of an unintended frequency setting when a setting value is rapidly increased or decreased with the MODIFY dial.

■ Operation procedure

1. Press the [Limit] soft-key and select [Setting Range]. Opens the setting window for the setting range limit. The operation can also be performed with shortcut keys.

In CV mode, press **SHIFT** + **V** or **SHIFT** + **F** to open the setting range limit window.

In CC mode, press **SHIFT** + **I** or **SHIFT** + **F** to open the setting range limit window.

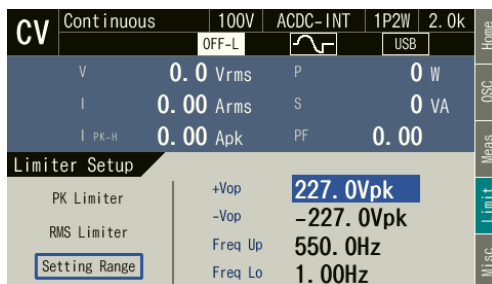

CV mode

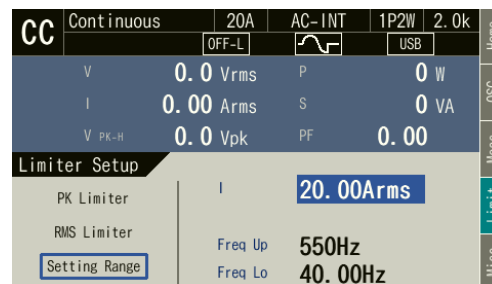

CC mode

2. In CV mode, set values in the [+Vop]/[-Vop] and [Freq Up]/[Freq Lo] items so that the upper value of the frequency setting range limit is higher than or equal to the lower limit.

In CC mode, set values in the [I] and [Freq Up]/[Freq Lo] items so that the upper value of the frequency setting range limit is higher than or equal to the lower limit.

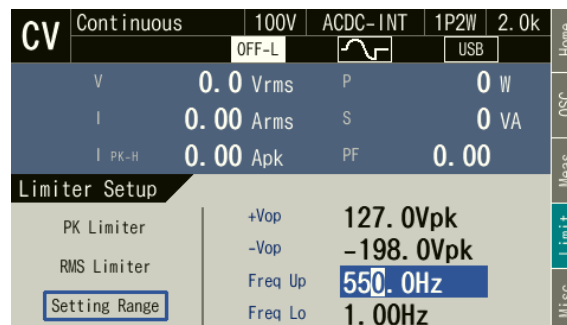

Note: The view is when in CV mode.

4.1.4 About Wattage Limiter

The wattage limiter operates when trying to output the power exceeding the rated power. When the wattage limiter operates, the output voltage or output current is suppressed until the output active power per unit is 2,100 W (reference value). While the limiter is working, the icon  is displayed and LIMIT LED illuminates.

----- Notes -----

- If the wattage limiter operates, suppress the output wattage within the rated output power by lowering the output voltage setting value.
- Active power (unit: W) is restricted by the wattage limiter, however, reactive power (unit: var) is not restricted. Therefore, the apparent power (unit: VA) may exceed the rated power depending on the power factor of the load. Set the output voltage so that the apparent power does not exceed the rated power, regardless of the operation of the wattage limiter.
- The value of the wattage limiter cannot be changed. To limit the output power to a value that is lower than the rating, use the peak (current/voltage) limiter or the RMS (current/voltage) limiter.

4.2 Using Sequence Function

4.2.1 Basics

By using Sequence function, an output setting can be changed step-by-step according to the program (sequence) created beforehand. This section describes the basics for using the Sequence function.

■ AC/DC Mode and Signal Source

With the Sequence function, the selections for the CV/CC mode, AC/DC mode, and signal source are kept independently from Continuous function/Simulation function. AC/DC mode can be selected from AC/ACDC/DC. A signal source is fixed as INT.

■ Keep a sequence setting

The sequence setting is kept per AC/DC mode. Every time AC/DC mode is changed, the sequence setting that is already kept is loaded. The sequence setting is cleared when the power is turned off. To save the setting, you need to save it in internal memory or USB memory (see 4.8).

■ Step

One sequence consists of a series of two or more steps. To use Sequence function, first set each step.

■ Step-control parameters and --Step parameters

There are the following two major types of parameters in Sequence function:

- Step-control parameter

Parameter to control the flow between two or more steps. These parameters determine the step duration time and the next step. Settings of step synchronous code and trigger output are included in step-control parameter for convenience.

- Intra-Step parameter

Parameter to define output state in each step. Along with basic parameters, such as waveform, frequency, and amplitude, it determines how these parameters change within each step.

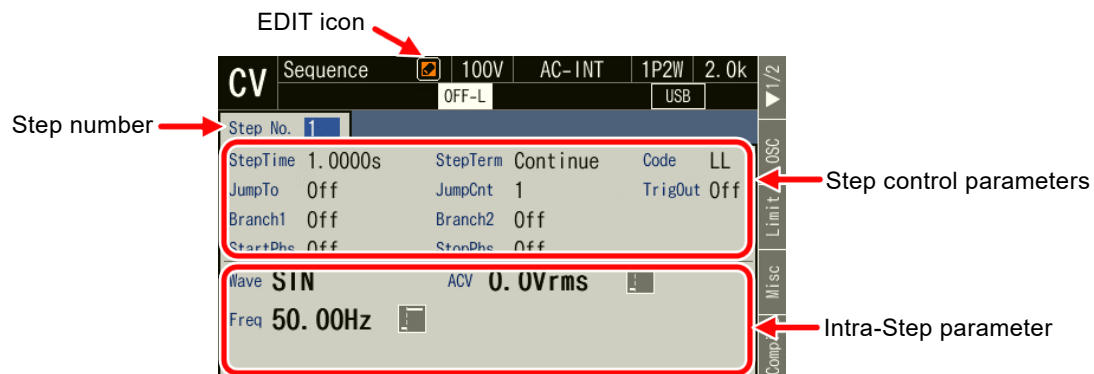

Figure 4-1 Step-control Parameters and Intra-Step Parameters

■ Step No. 0

Step No. 0 is assigned to the stand-by state before the sequence starts. If the terminal specification of the step other than No. 0 is End, the execution transitions to step No. 0 and enters into the stand-by state. Step Time and the Step Behavior setting of No. 0 specifies the action to transit to No. 0 at the end of a sequence.

■ Step Behavior (Const, Sweep, Keep)

For the intra-Step parameter other than waveforms and phases, the following three patterns can be set as the method to change values in the step.

- Constant (Const)

Fixed to the value set in the step.

- Sweep

It changes linearly from the value immediately before transitioning to the value set in the step, taking the Step Times. This means, after the lapse of the Step Time in that step, the value reaches the set value. The starting value changes according to the status of the previous step.

- Keep

Keeping the value immediately before transitioning to the step. This means, the value changes according to the status of the previous step. Although the parameter value can be set even if the operation type setting is Keep, the parameter setting value is ignored when sequence is executed.

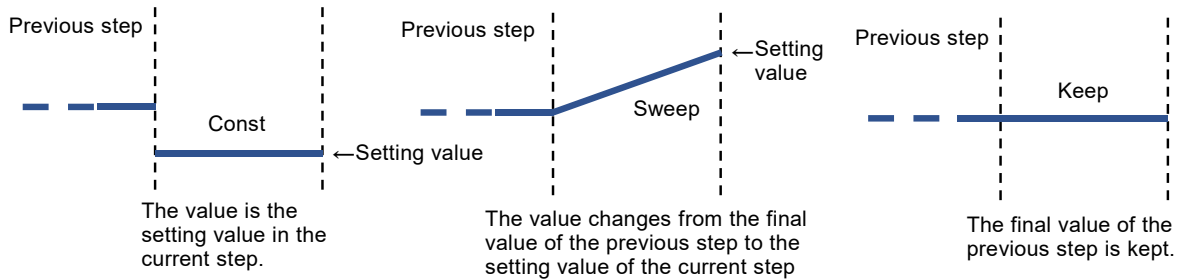
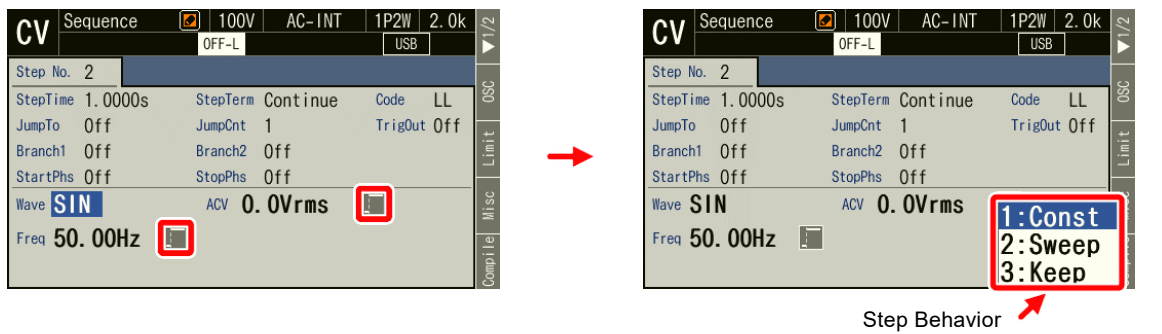

Figure 4-2 Step Behavior

Notes

- The Step Behavior for the waveform and phase is always Constant (Const).
- Keeps as many intra-Step parameter setting values as the number of phases in each step based on the output phase configuration.
- Cannot be set using line voltage in the 1P3W output and three-phase output.
- The rate of crest factor/clip ratio cannot be changed though a clipped sine wave can be selected as an output waveform in Sequence function. Set these parameters beforehand using Continuous function.
- Sequence function displays the measured value in Sequence function, which is equivalent to that of the Continuous function. However, harmonic current measurement (see 4.4) cannot be displayed.

4.2.2 Parameters of Sequence Function

Table 4-1 shows the parameters of Sequence function. The common parameters are common to one sequence. In Sequence function, signal source is fixed to INT. In each step, set the step-control parameter and the intra-Step parameter. As for intra-Step parameter, the item and range that can be set differ depending on the output range (100 V/200 V range) and output mode (AC-INT/ACDC-INT/DC-INT) as in the case of Continuous function. This section describes intra-Step parameters and step-control parameters separately.

Table 4-1 Parameters of Sequence Function

Common parameter	Step control parameters	Intra-Step Parameter
Output range CV/CC mode AC/DC mode	Step Time Specification of the Jump-to step Jump count (1 to 9999, or infinite) Specification of the branch step Step termination Step sync code output (2bit) Start Phase Stop Phase Trigger output	Frequency Waveform Phase angle AC phase voltage DC voltage

- Frequency (Freq), waveform (Wave), phase angle (Phase), AC phase voltage (ACV), DC voltage (DCV)

The setting for the output of each step. In a polyphase system, the output (voltage of CV or current of CC) and phase angle can be set for each phase. In the phase angle, set the phase difference with the L1 phase. Phase angle can also be set per step. The phase angle of L1 phase cannot be set, and is fixed as 0°.

- Step Time (Step Time)

Set the output time of that step. Unit can be selected from [s] or [ms].

- Jump-to step (Jump To)

When selected, the destination step of the jump at the end of the step can be specified. By specifying the Jump count ([Jump Cnt]), you can set up a loop to repeat the same step. After jumping for the times specified for one sequence, the action at the end of step follows the step termination setting.

If Jump-to is set to off, the action at the end of step follows the step termination setting.

----- Notes -----

- When the step termination is set as [Hold], the hold status is enabled before the jump.

- Jump count (Jump Cnt)

Number of times of jumps to jump to the step specified in Jump-to. This can be set when Jump-to ([Jump To]) is selected. When the Jump count is set to 0, infinite times of jumps occur.

----- Notes -----

- The number of times that a particular step is repeated is Jump count +1.

■ Branch step (Branch1, Branch2)

When the step is under execution or in the hold state, the step to transition when the branching instruction through panel operation or CONTROL I/O is detected can be specified. There are two systems of branch instructions (Branch1 and Branch2), and an instruction can be set for each.

----- Notes -----

- Transition using branch is executed immediately after a branching instruction is detected. Step Time, Stop Phase, and step termination setting are ignored.

■ Step termination (Step Term)

Specifies the action when the step completes. When [Continue] is selected, transitions to the step of the next number. When [End] is selected, the sequence is terminated and the execution transitions to step No. 0 and enter into the stand-by state. When [Hold] is selected, the output at the end of the step is suspended, and the execution transitions to the step of the next number when Resume instruction is detected.

----- Notes -----

- When [Step Term] is set to [Hold], the execution enters into hold state before jump. Jumps when Resume instruction is detected.
- When [Step Term] is set to [Hold], after the jumps repeated for the specified Jump count, the execution transitions to the step of the next number when Resume instruction is detected in hold state.
- While in the hold state due to the step termination in a step where step termination phase is enabled, the execution transitions to Jump-to step or the step of next number when Resume instruction is detected, after the hold state is kept until Stop Phase.

■ Step sync code output (Code)

State output to CONTROL I/O connector. Code to output while the execution of the step, which is specified by 2-bit H/L.

■ Start Phase (StartPhs)

Determines the phase of AC waveform of L1 phase when the step starts. The phase when a step starts in L2 and L3 phase of polyphase system is the addition of the setting value of intra-Step parameter Phase and the setting value of the step Start Phase.

----- Notes -----

- Step Start Phase setting can be disabled. In that case, the phase when the phase starts becomes the phase when the previous step ended.
- In DC, the step Start Phase cannot be set.

■ Stop Phase (Stop Phs)

Determines the phase of AC waveform when the step ends. The phase when a step ends in L2 and L3 phase of polyphase system is the addition of the setting value of intra-Step parameter Phase and the setting value of the step Stop Phase. When the stop phase setting is active, the execution waits for the Step Time that was set pass, and keeps the output setting until it reaches the Stop Phase that was set, and then transitions to the next step. As the result, the actual Step Time is longer by one cycle at a maximum than the set Step Time. *Figure 4-3* shows an example where both the Stop Phase of the previous step and the Start Phase of the next step are set to 0° .

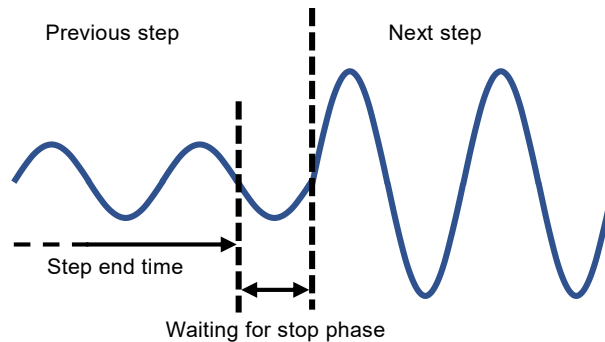

Figure 4-3 Stop Phase

Notes

- When the Step Behavior is set to [Sweep], output is constant while waiting for the step Stop Phase after the Step Time passes.
- Step Stop Phase setting can be disabled. In this case, when the set Step Time has passed, the execution transitions to the next step without waiting for step Stop Phase.
- In DC, the step Stop Phase cannot be set.

■ Trigger output(Trig Out)

State output to CONTROL I/O connector. This specifies whether the trigger output presents when the step starts. Polarity and pulse width of the trigger output complies with the trigger output setting (see 4.2.5).

4.2.3 Example of Output Using Sequence Function

As an example, consider the sequence that gradually changes DC voltage like *Figure 4-4*.

Set the output mode to DC-INT. Edit the sequence like *Table 4-2*. Parameters not included in this table should be left as the factory default setting.

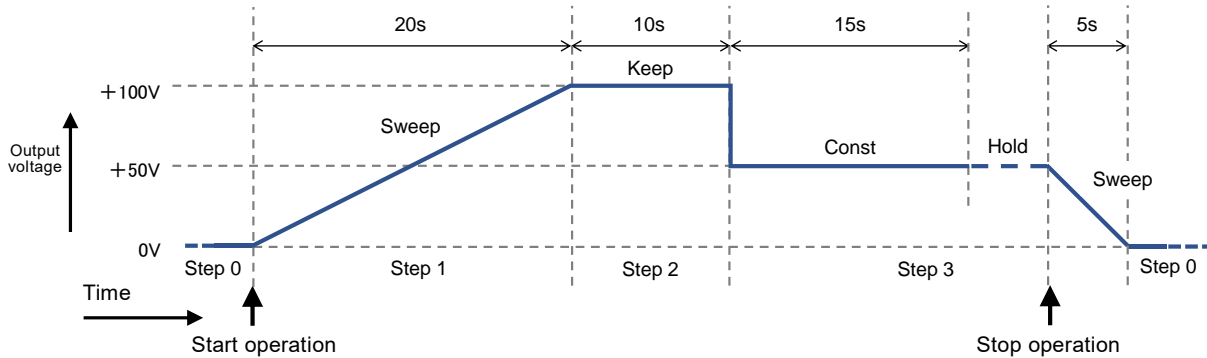

Figure 4-4 Example of Sequence (CV mode)

Table 4-2 Example of Editing Sequence (CV mode)

Step number		0	1	2	3
Step control parameters	Step Time (Time)	5 s	20 s	10 s	15 s
	Jump-to (Jump To)	–	OFF	OFF	OFF
	Step termination (Step Term)	–	Continue	Continue	Hold
Intra-Step parameter	DC Voltage (DCV)	0 V	+100 V	(Optional)	+50 V
	Step Behavior	Sweep	Sweep	Keep	Const

Notes

- Step Time and the Step Behavior of step No. 0 specifies the action after the transition to step No. 0 at the end of a sequence.
- Jump-to of step No. 0 cannot be specified. The execution always transitions to step No. 1 when the sequence starts.
- In the case that the step termination is set to [Hold] (No. 3), and when the execution is in the Hold state, it transitions to step No. 0 and enters into the stand-by state if the Stop operation is executed. If you perform Resume operation here, the execution transitions to the step of the next number (No. 4).

4.2.4 Process Flow in a Step

Figure 4-5 shows the process flow in one step. The transition such as *Figure 4-6* occurs by branch operation or stop operation, regardless of the flow in the step.

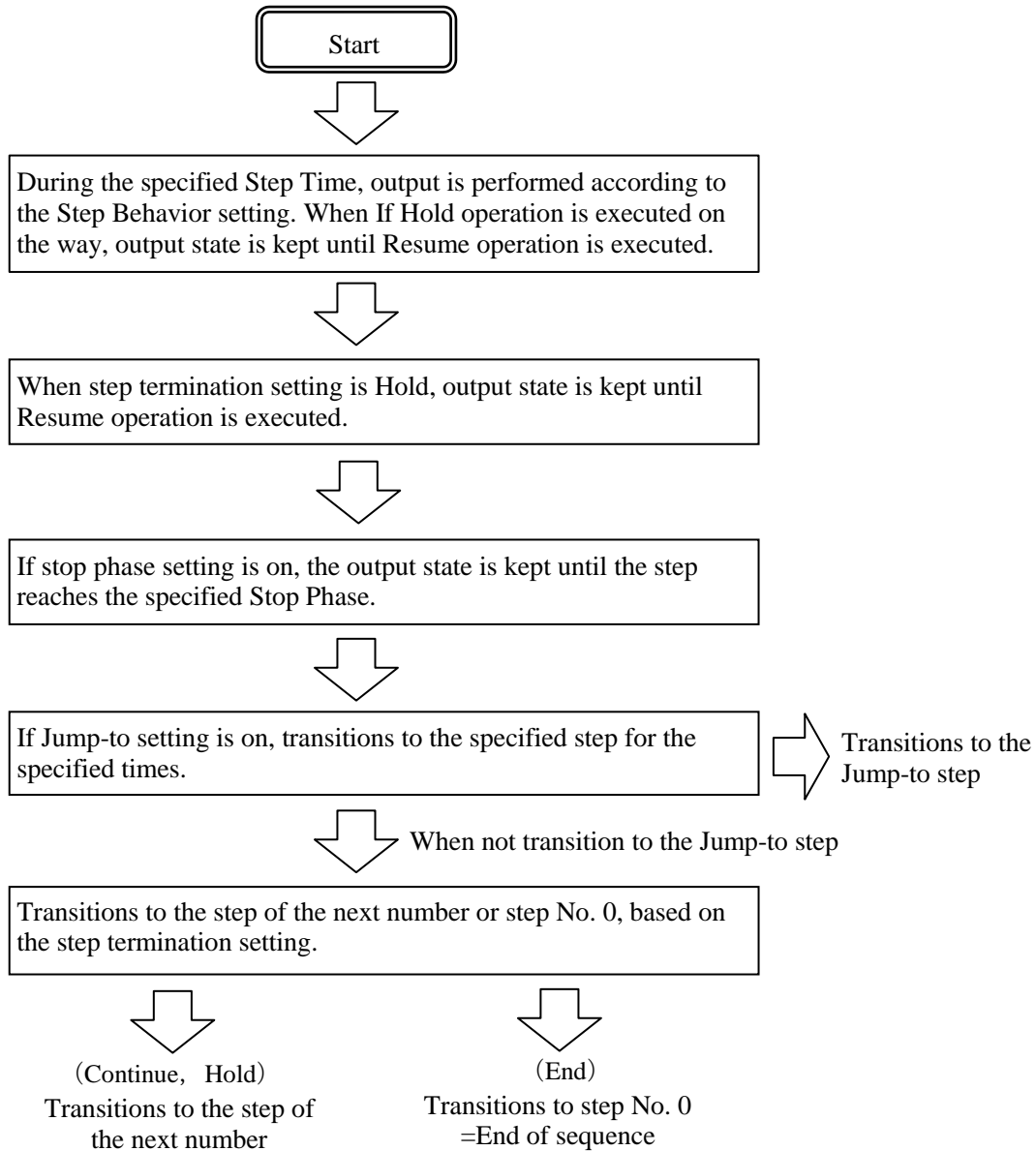

Figure 4-5 Process Flow in Sequence Step

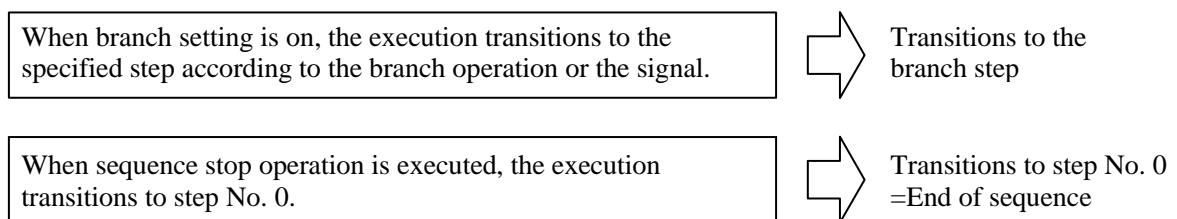

Figure 4-6 Branch Operation/Stop Operation

4.2.5 Edit a Sequence

----- Notes -----

- A sequence being edited is kept per AC/DC mode. If AC/DC mode is changed, the edited contents of sequence are loaded based on the change.
- When the power is turned off, edited contents of the sequence are cleared, and all sequences have the default setting values when it is started next time. To keep the edited contents of sequence, save them in the Sequence Memory (see 4.2.9).
- When the sequence is loaded from Sequence Memory, the sequence being edited at that time is discarded.
- You can also turn the output on in the Sequence Edit View. In this case, the output will be set to the state set in the Step No.0 when the sequence was last compiled. (See 4.2.8)

■ Transit to Sequence Edit View

Press the MENU key to open the root menu, then select [Sequence] (see 3.3.1). While the Sequence Control View is displayed, if you push the [Edit] soft-key, the execution transitions to the Sequence Edit View.

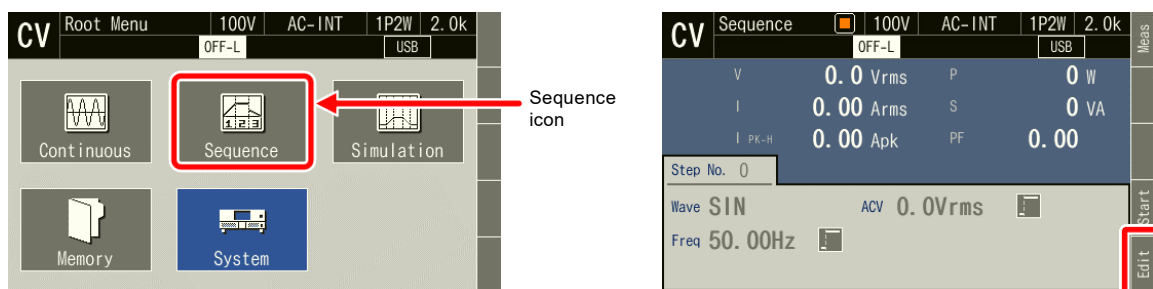

■ Edit a sequence

1. Push [OSC] soft-key on Sequence Edit View, then select AC/DC mode and 100 V/200 V range. To edit the saved sequence, load the sequence (see 4.2.7).

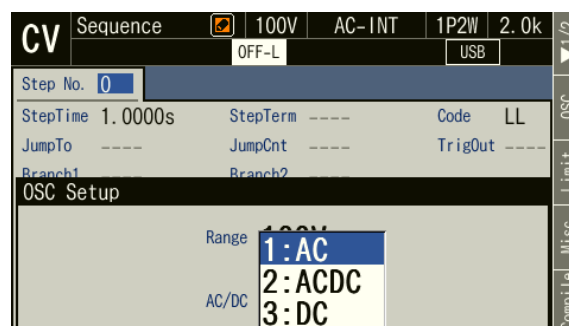

4. Advanced Operation

2. Set the parameter of each step. You can move between each step by changing [Step No.].

Also, even if the cursor is not on the [Step No.] item, you can move to the previous step by pressing **PREV**, and to the next step by pressing **NEXT**.

Also, you can move to the first step by pressing **SHIFT** + **PREV**, and last step by pressing **SHIFT** + **NEXT**.

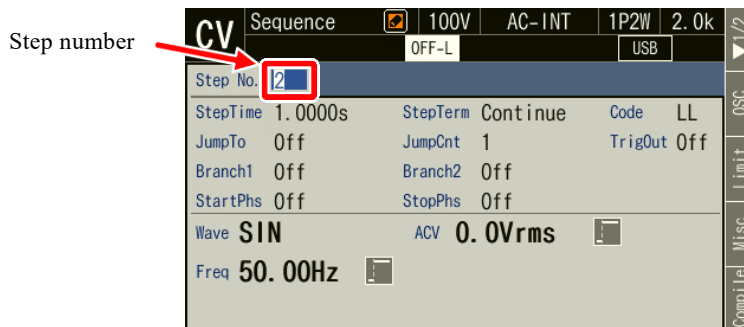

3. Press the [Misc] soft-key to open the Misc Setup window. You can set the polarity and pulse width of the trigger output in [Trig Out]. You can select s or ms as the unit of Step Time in [TimeUnit].

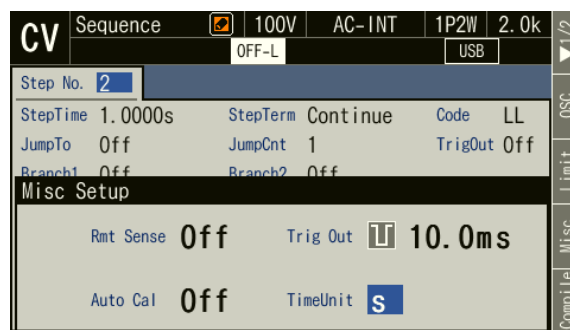

4.2.6 Displaying Data List View of Sequence Memory

You can access this product's internal memory and USB memory to save, recall, clear, and rename sequences.

■ Displaying a saved sequence

1. In Sequence Edit View, select [File] on soft key page 2. Sequence Memory View opens.

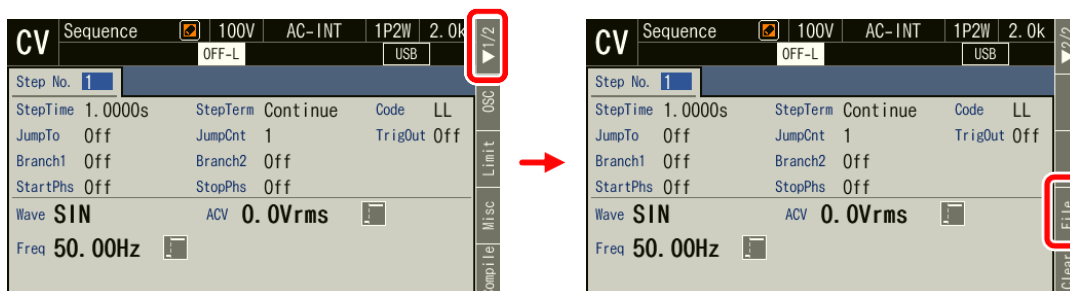

2. The sequence memory data list appears. Select reference target [1: System] (internal memory) / [2: USB] (USB memory) in the [Target] item.

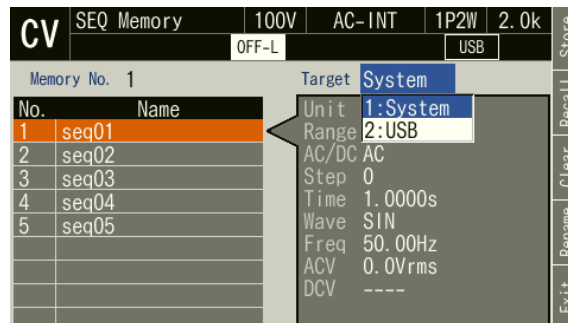

3. Specify the memory number to reference in the [Memory No.] item.

Even if the cursor is not on the [Memory No.] item, you can move to the previous number by pressing **PREV**, and to the next number by pressing **NEXT**.

Also, you can move to the first number by pressing **SHIFT** + **PREV**, and last number by pressing **SHIFT** + **NEXT**.

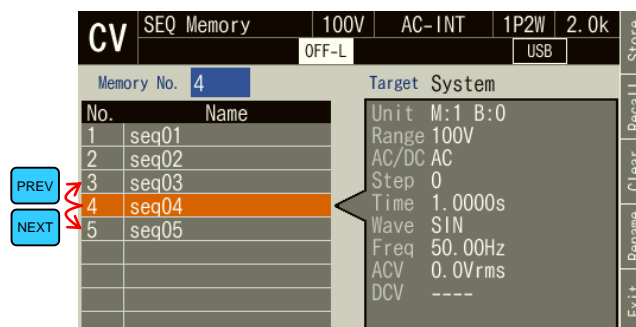

4. If you push the [Exit] soft-key, the execution transitions back to the Sequence Edit View.

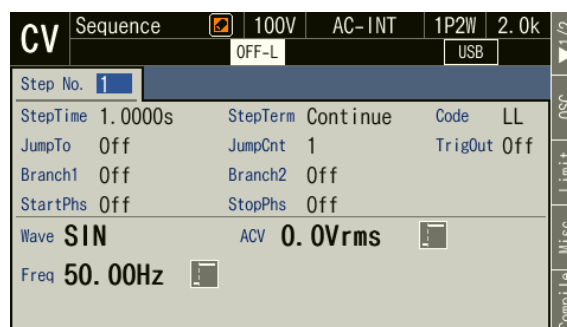

Notes

- You can also open Sequence Memory View by pressing the menu key to move to the root menu and then selecting Memory → Sequence Memory (see 4.7.4). In this case, pressing the [Exit] soft-key returns to Memory View.

4.2.7 Load a Sequence

----- Notes -----

- When the sequence is loaded, the sequence being edited at that time is discarded.
- In Sequence Control View, a sequence cannot be loaded.
- For how to connect USB memory to this product, and how to disconnect from this product, see 4.8.
- The number of sequence data files saved in a USB memory should be 500 or less. If the number of files exceeds this limit, this product cannot recognize the sequence data files in the USB memory.

■ Recalling a saved sequence

1. Open Data List View of sequences (see 4.2.6). Select the [Target] and [Memory No.] items and specify the sequence to recall, then press the [Recall] soft-key.

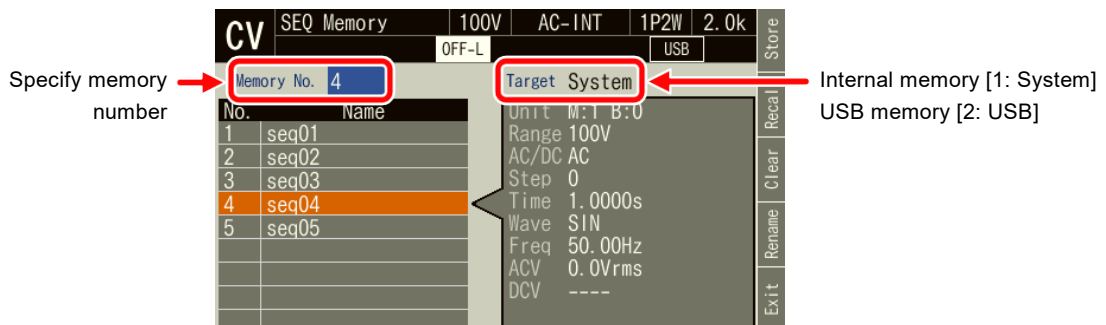

2. The confirmation window for loading the sequence opens. Select [OK]. The sequence with the specified memory number is loaded.

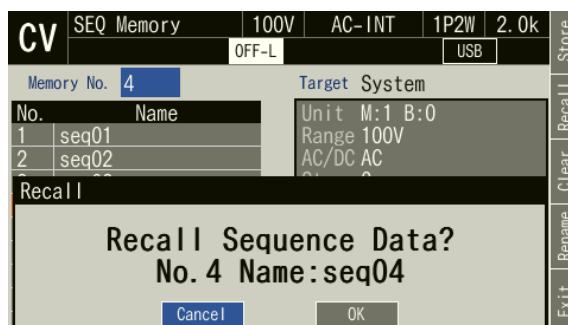

4.2.8 Execute a Sequence

The edited sequence can be executed after converted to executable program by compile operation.

■ Transition to Sequence Control View

When pushing [Compile] soft-key in the Sequence Edit View, the edited sequence is compiled, and then the screen transitions to Sequence Control View. If output is turned on in the Sequence Edit View, the output transitions to the state set in the step No.0 at the same time as compiling.

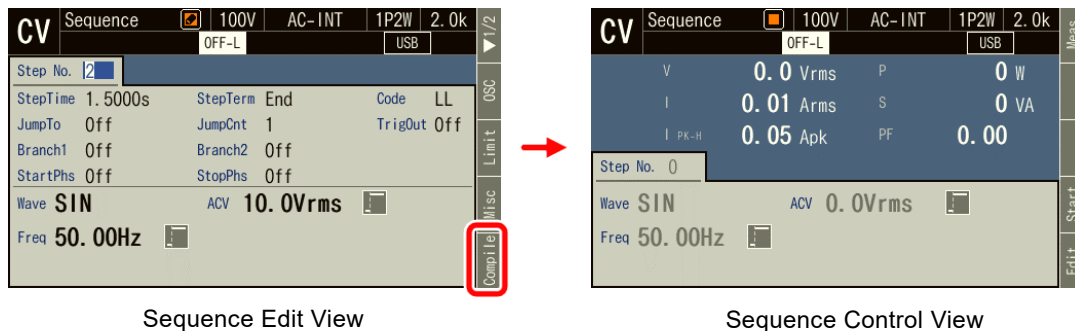

----- Notes -----

- If an improper setting is detected during compilation, an error message is displayed and the screen does not transition to the Sequence Control View.

■ Start/Terminate a sequence

1. If output is turned off in the Sequence Edit View, the sequence can be executed when output is turned on in the Sequence Control View. At this point, the output is in the state set in the step No. 0.

When a sequence is stopped, the icon is displayed.

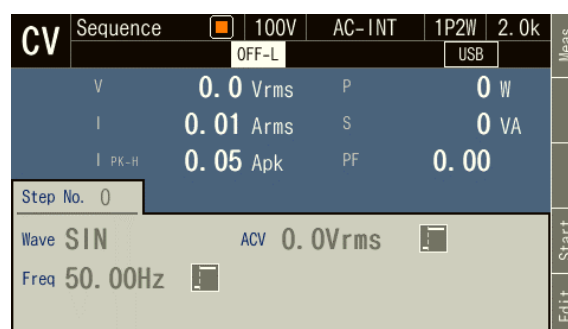

4. Advanced Operation

- When pushing [Start] soft-key, the sequence is started. While the sequence is executed, the icon  is displayed.

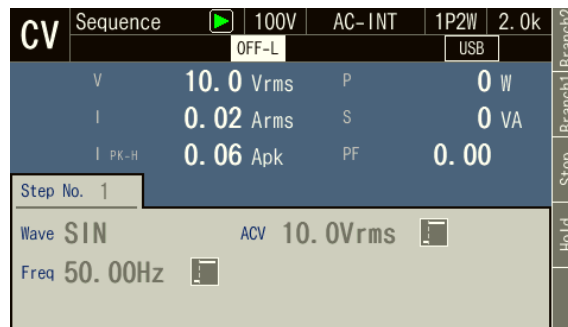

- When [Stop] soft-key is pushed while sequence is executed, the execution transitions to the output state that is set in the step No. 0, and then sequence is terminated. The output remains on.

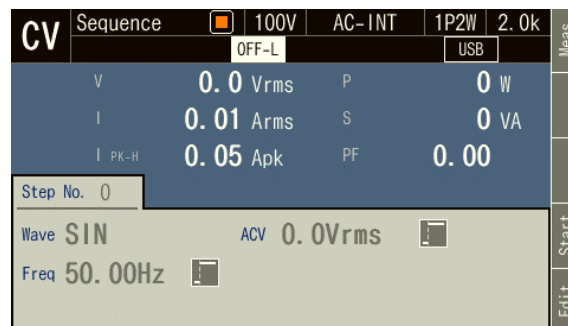

Notes

- In the output off state, the sequence cannot be started.
- Output on/off setting is not active in sequence.

Return to Sequence Edit View

If you push the [Edit] soft-key, the execution transitions back to the Sequence Edit View.

Suspend a sequence

- When pushing [Hold] soft-key while a sequence is executed, the sequence is suspended. The output state is kept while suspended. Icon  is displayed.

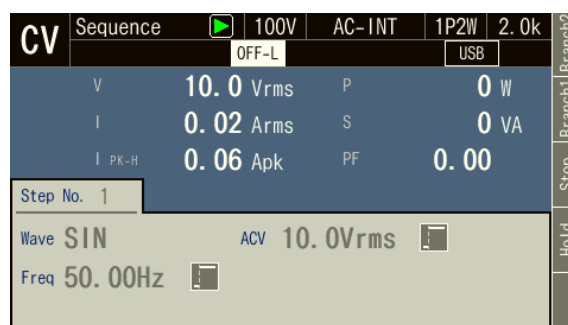

- To restart the sequence, push [Resume] soft-key. If you push [Stop] soft-key, the execution transitions to step No. 0 and the sequence is terminated.

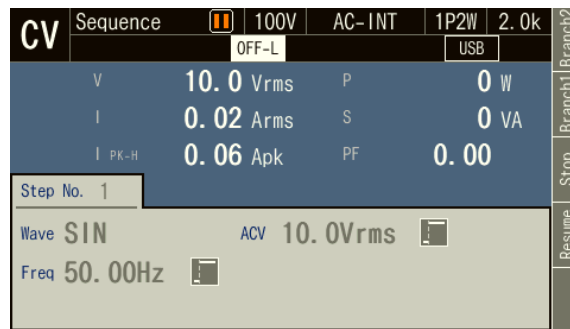

■ Branch a sequence

If you push [Bran1] or [Bran2] soft-key while a sequence is executing, the execution transitions to the branch step 1 or 2 that is set in the step being executed.

Example: In step 3, set Branch 1 to step 5

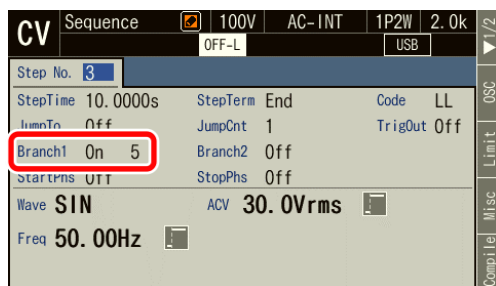

Sequence Edit View

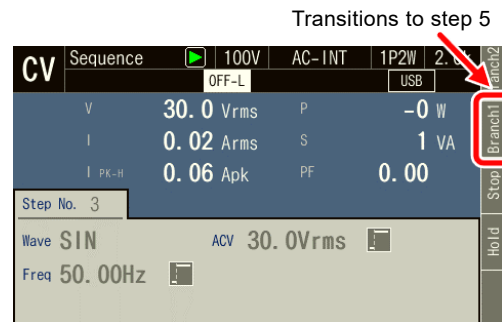

Sequence Control View

4.2.9 Save a Sequence

----- Notes -----

- In Sequence Control View, a sequence cannot be saved.
- All sequence data that are edited in each mode of AC/DC mode are saved as one memory number/file by one save operation.

■ Save a sequence to internal memory

1. Open Data List View of sequences (see 4.2.6). Select the [Target] and [Memory No.] items and specify the sequence to save, then press the [Store] soft-key.

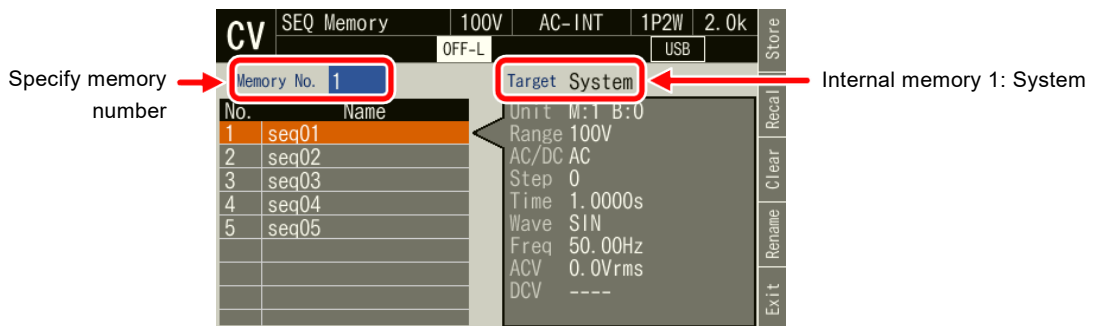

2. A window to confirm saving opens. Select [OK].

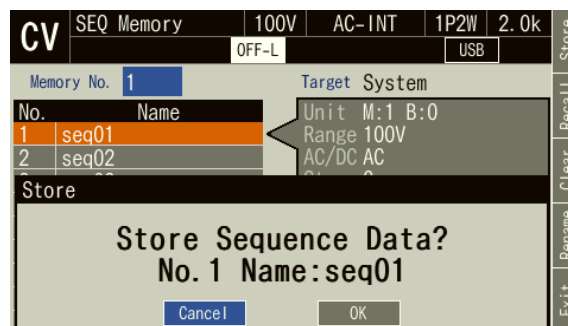

■ Save a sequence to USB memory

For how to connect USB memory to this product, and how to disconnect from this product, see 4.8.

1. Open Data List View of sequences (see 4.2.6). Select the [Target] and [Memory No.] items and specify the sequence to save, then press the [Store] soft-key. When saving a new sequence, specify a number for which [Name] is blank in the data list.

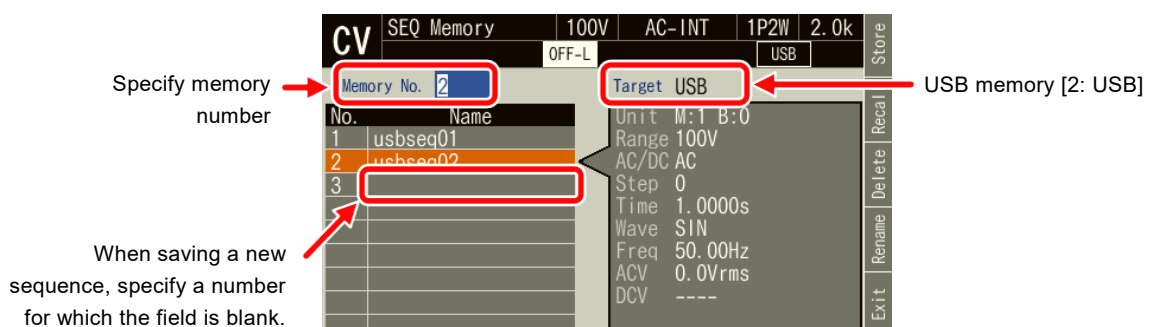

- When overwriting a sequence, a window to confirm saving opens. Select [OK]. When saving a new sequence, a window to enter the name for saving opens. Enter the name, and then select [OK]. For how to enter a string, see 3.3.6.

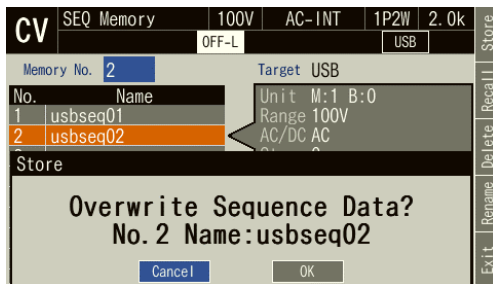

Confirmation window
(when overwriting a sequence)

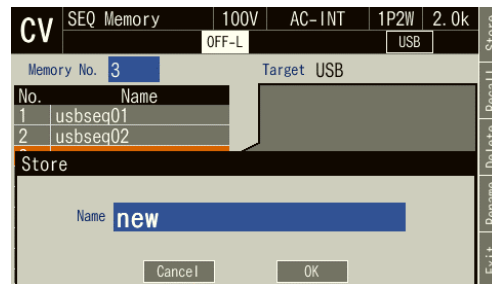

Confirmation window
(when saving a new sequence)

Notes

- The number of sequence data files saved in a USB memory should be 500 or less. If the number of files exceeds this limit, this product cannot recognize the sequence data files in the USB memory.

4.2.10 Clear/Rename Sequence

■ Clear/Rename a sequence saved in internal memory

- Open Data List View of sequences (see 4.2.6). Select the [Target] and [Memory No.] items and specify the sequence to clear or rename.



4. Advanced Operation

- To clear, push [Clear] soft-key. Confirmation message is displayed. Select [OK]. In the cleared number of the memory, the sequence data at factory shipment is stored.

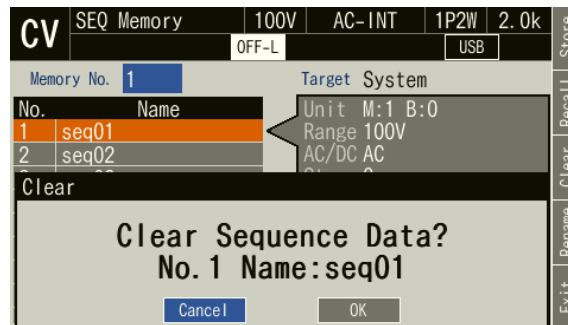

- To rename, push [Rename] soft-key. Rename window opens. Enter a new name and then select [OK]. For how to enter a string, see 3.3.6.

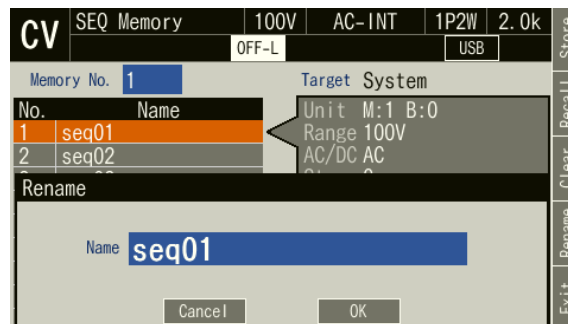

■ Delete/Rename a sequence saved in USB memory

For how to connect USB memory to this product, and how to disconnect from this product, see 4.8.

- Open Data List View of sequences (see 4.2.6). Select the [Target] and [Memory No.] items and specify the sequence to clear or rename.

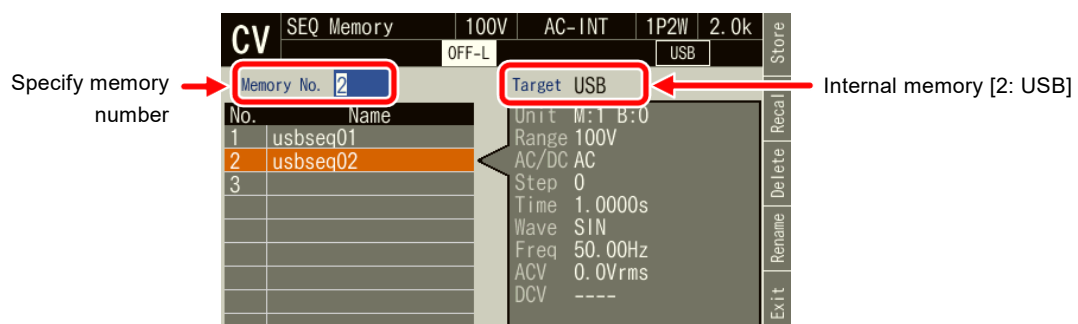

- To clear, push [Delete] soft-key. Confirmation message is displayed. Select [OK]. The corresponding file in USB memory is deleted.

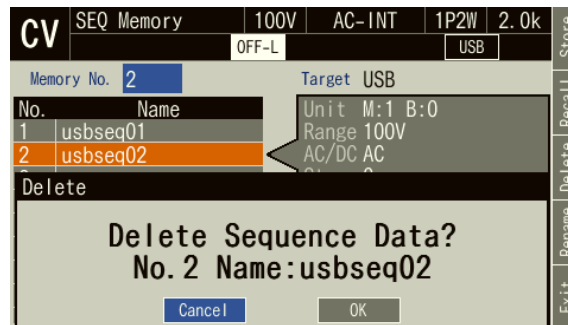

- To rename, push [Rename] soft-key. Rename window opens. Enter a new name and then select [OK]. For how to enter a string, see 3.3.6.

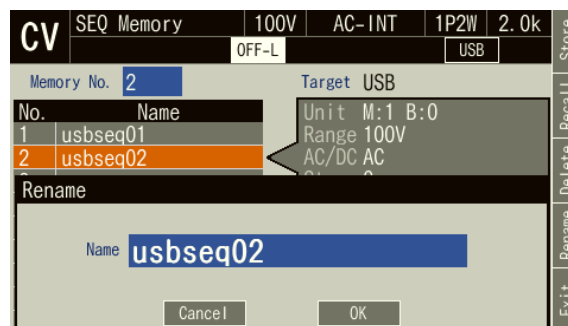

4.2.11 Set so as the Sequence Function is Selected at Power-on

You can set so as the Sequence function is selected at power-on.

■ Operation procedure

- Press the MENU key to move to the root menu, and then select [System]. The system setting window opens.

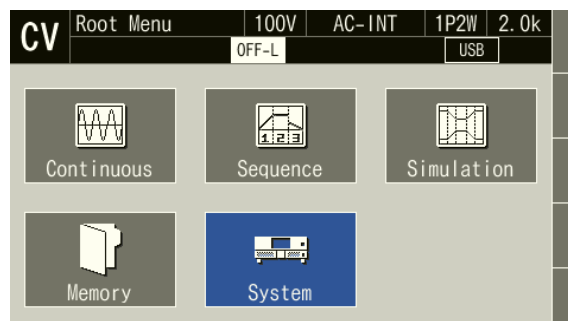

- In the [PwOn Mode] item on page 2 of the system setting window, select [2: Sequence].

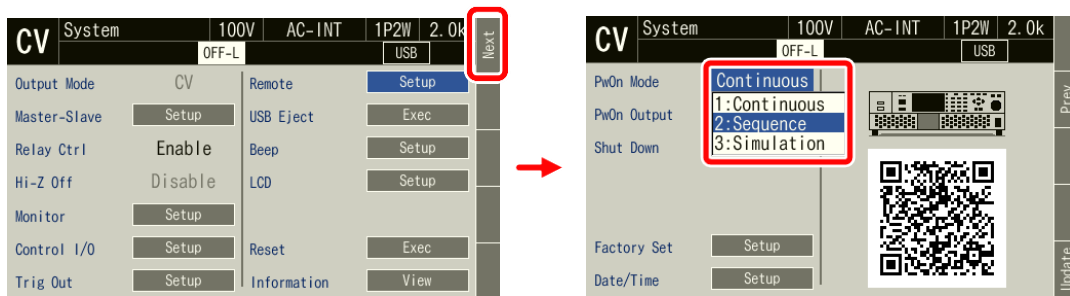

----- Notes -----

- To set so as to Continuous function is selected at power-on, select [1: Continuous] in [PwOn Mode] item.

4.2.12 Sequence Control by CONTROL I/O

CONTROL I/O enables to start/stop/suspend/branch a sequence and to recall the memory. For details, see 4.18.

4.2.13 Screen Overview

The Sequence function view is broadly separated into the Sequence Edit View and the Sequence Control View. It is Sequence Edit View that is displayed when sequence icon is selected from the root menu. After pushing [Compile] soft-key in Sequence Edit View, the screen transitions to the Sequence Control View.

----- Notes -----

- You cannot transition to root menu by pushing the MENU key in the Sequence Control View. To transition to the root menu, first move to the Sequence Edit View and then push the MENU key.

■ Sequence Edit View

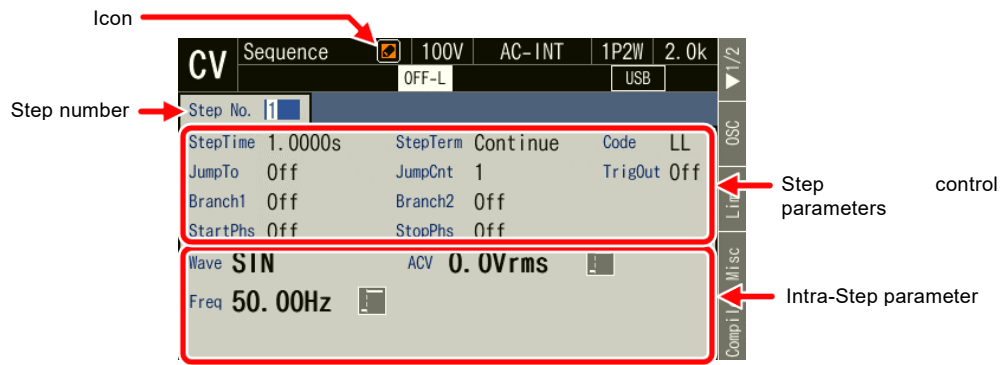

Figure 4-7 Sequence Edit View

■ Sequence Control View (output off state/sequence stopped)

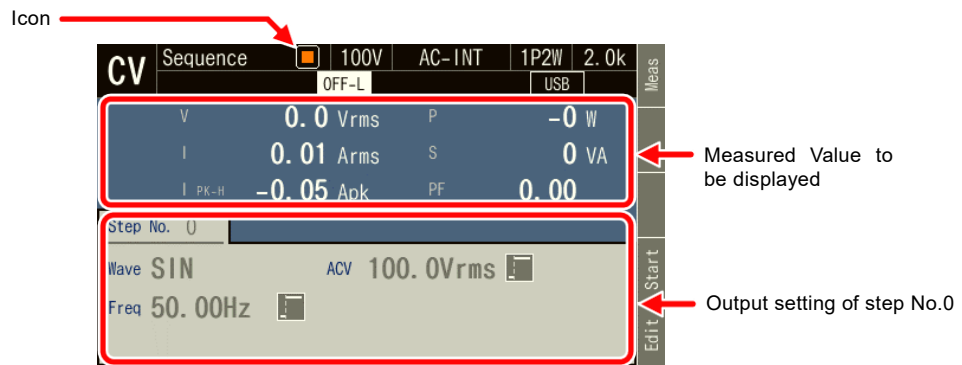

Figure 4-8 Sequence Control View (Output Off State)

■ Sequence Control View (output on state/sequence in execution)

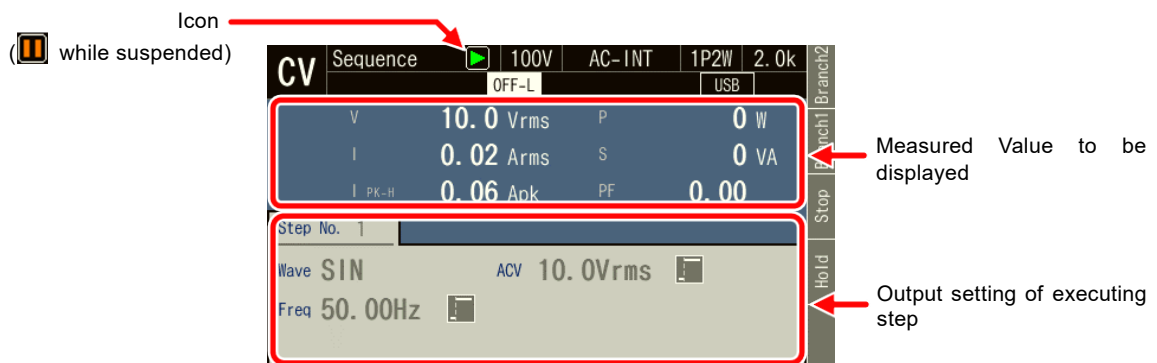

Figure 4-9 Sequence Control View (Output On State/Sequence in Execution)

■ Sequence Control View (output on state/sequence stopped)

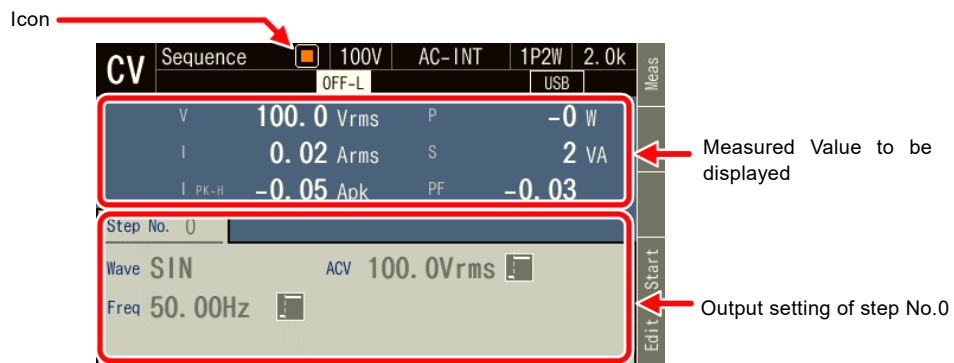
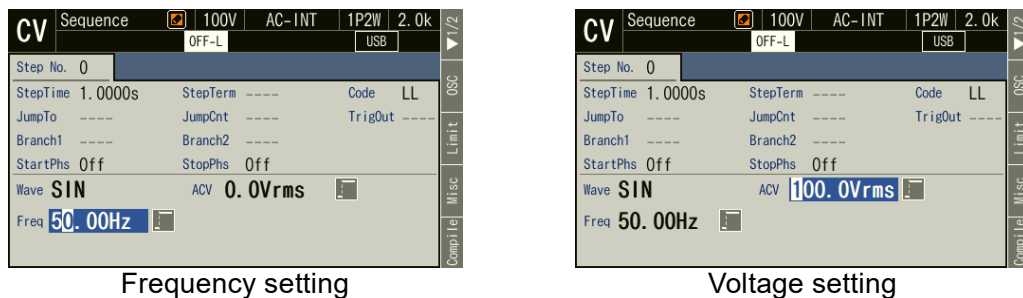

Figure 4-10 Sequence Control View (Output On State/Sequence Stopped)

4.2.14 Change Output Parameter during Output ON

Frequency and voltage of step No.0 can be changed on Sequence Edit View and it can be used like Continuous output function. Remote Sensing function and Autocal function can be enabled. See 4.11 and 4.13 for detail of Remote Sensing function and Autocal function.

1. Select frequency and voltage, input them in the Sequence Edit View step No.0 and turn ON output, setting voltage will be output. Changing setting value, it will be applied soon.



2. When pushing [Compile] soft key in the Sequence Edit View, moved to Sequence Control View. You can check measurements in step No.0. When pushing [Start] soft-key, the sequence is started.

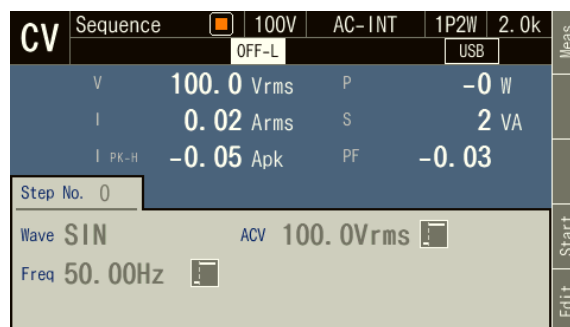

3. Remote Sensing function and Autocal function can be enabled in step No.0 in the Sequence Edit View and the Sequence Control View.

■ Turning on the Remote Sensing Function

1. Shortcut operation: Press **SHIFT** + **5** or the [Misc] soft-key to open the Misc Setup window.
2. Use the [Rmt Sense] item to set the Remote sensing function to on or off.
3. Close the window.



Sequence Edit View



Sequence Control View

■ Turning on the Autocal function

1. Turn on the output.
2. Shortcut operation: Press **SHIFT** + **5** or the [Misc] soft-key to open the Misc Setup window.
3. Use the [Rmt Sense] item to set the Remote sensing function to on or off, if necessary.
4. Select [2: On] in the [Auto Cal] item. In case within operating range of Autocal when [ON] is selected here, the calibration factor of the Autocal function is calculated, and the calibration is started.
5. Close the window.



Sequence Edit View



Sequence Control View

Notes

- The Remote Sensing Function or Autocal function can be set to on in the AC-INT, ACDC-INT and DC-INT modes. However, for the AC or ACDC, it can be set to on only when the waveform is a sine wave. If changing waveform to clipped sine wave when Remote Sensing setting is ON, Remote Sensing and Autocal setting is forcibly turned off.
- In ACDC, Remote Sensing and Autocal setting cannot be enabled unless either AC voltage setting value or DC voltage setting value is 0 V. Also when such a setting is made by sequence memory recall, Remote Sensing and Autocal setting is forcibly turned off.
- When the AC/DC mode is changed, Remote Sensing and Autocal settings are first turned off. Turn ON it again when you need.
- If changing setting by sequence memory recall or memory clear, the screen display will be changed, but the output will be applied after compile.

4.3 Using Power Fluctuation Testing (Simulation) Function

4.3.1 Basics

The Power fluctuation testing (Simulation) function allows you to edit and output voltage patterns that simulate power line anomalies such as blackout, voltage rise, voltage drop, abrupt phase change, and abrupt frequency change. This section describes the basics for using the Simulation function.

This function can be used in CV mode only.

■ AC/DC Mode and Signal Source

Simulation function sets the AC/DC mode and a signal source, independently from Continuous function/Sequence function. The setting is fixed to ACDC-INT.

■ Keep simulation setting file

The simulation setting is cleared when the power is turned off. To save the setting, you need to save it in internal memory or USB memory (see 4.8).

■ Step

The output by the Simulation function consists of six types of steps: Initial, Normal 1, Trans 1, Abnormal, Trans 2, and Normal 2. Before the simulation starts, the DP020AGS stands by at the Initial Step. During the simulation, the step changes in the order of Initial, Normal 1, Trans 1, Abnormal, Trans 2, and Normal 2. After the simulation ends, the DP020AGS returns to the Initial Step and stands by.

■ Step parameter

Each parameter of Step Time, AC voltage, frequency, Start Phase, Stop Phase, trigger output, and synchronization output can be set for each step. However, some parameters cannot be set in some steps.

■ Initial Step

Initial Step is assigned to the stand-by state before the simulation starts. The DP020AGS also moves to the Initial Step and becomes stand-by state after the simulation ends, except when the repeat count is specified to 0 (= infinite count).

■ Transition Step (Trans 1 and Trans 2)

The Step Times of Trans 1 and Trans 2 can be set to zero for simulating the abrupt voltage and phase changes. When the Step Time is set to the value other than zero, the set voltage and frequency are swept linearly at the previous and next steps. Note that the AC voltage, frequency, Start Phase, and Stop Phase cannot be set in the Transition Steps.

■ Other issues

- The Exit operation is available during the simulation. Performing the Exit operation moves to the Initial Step. The output remains on.
- You can set the repeat on/off and repeat count for the simulation. When the repeat is set to on and the repeat count to zero (0), the testing repeats infinitely.

----- Notes -----

- The Simulation function does not support the standard tests defined by organizations such as IEC. Use this function for a preliminary testing.
-

4.3.2 Simulation Function Parameters

Table 4-3 shows the parameters of Simulation function. The common parameters are common to one simulation. In the Simulation function, the signal source is fixed to INT sine wave and the ACDC mode to ACDC. When in polyphase, the balanced mode is always used. In each step, set the step-control parameter and the intra-Step parameter. As for intra-Step parameter, the range that can be set differ depending on the output range (100 V/200 V range) as in the case of Continuous function.

Table 4-3 Simulation Function Parameters

Common parameter	Step control parameters	Intra-Step parameter
Output range AC/DC mode (Fixed to ACDC) Waveform (Fixed to sine wave)	Step Time Start Phase Stop Phase Trigger output Step sync code output (2bit) Repeat count (1 to 9999 or infinite)	Frequency AC voltage

■ Relationship between each step and settable Step parameters

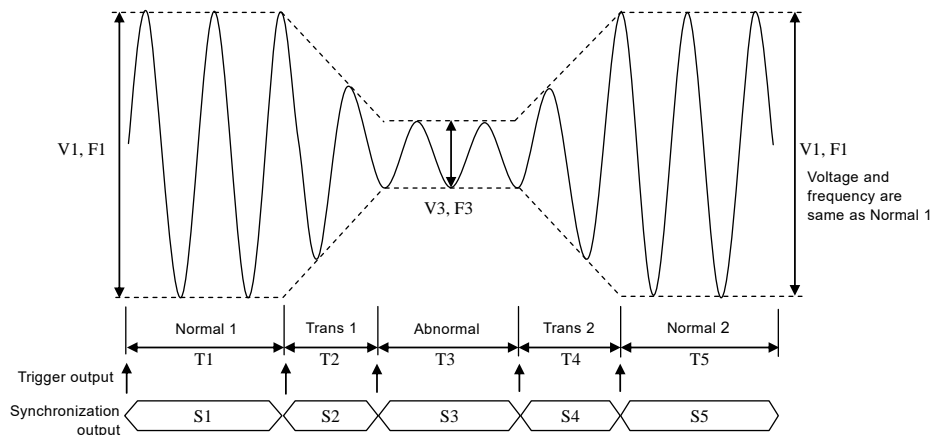

Figure 4-11 Simulation Function Steps

Table 4-4 Simulation Function Steps and Settable Step Parameters

Step	Initial	Normal 1	Trans 1	Abnormal	Trans 2	Normal 2
Step Time	—	T1	T2	T3	T4	T5
AC voltage	V0	V1	—	V3	—	— (=1)
Frequency	F0	F1	—	F3	—	— (=1)
Start Phase	ON/OFF P0	ON/OFF P1	—	ON/OFF P3	—	ON/OFF P5
Stop Phase	ON/OFF Q0	ON/OFF Q1	—	ON/OFF Q3	—	ON/OFF Q5
Trigger output	—	ON/OFF	ON/OFF	ON/OFF	ON/OFF	ON/OFF
Synchronization output	S0	S1	S2	S3	S4	S5

Note: “—” means that this parameter cannot be set.

■ Start Phase (StartPhs)

ON or OFF can be selected for the Start Phase. When ON is selected, the step starts at the specified Start Phase. When OFF is selected, the step starts at the phase in which the previous step ended. When selecting ON, a numerical entry box in which you can specify the Start Phase opens.

The Start Phase can be set at the Normal 1, Normal 2, and Abnormal steps. For other steps, the Start Phase is fixed to OFF and cannot be specified.

■ Stop Phase (Stop Phs)

ON or OFF can be selected for the Stop Phase. When ON is selected, the step ends at the specified Stop phase. If the phase is not the specified Stop Phase after the Step Time elapsed, the execution continues the output of that step until reaching the specified Stop Phase, then performs the next step. When OFF is selected, the step transitions to the next step when the Step Time has elapsed regardless of the phase. When selecting ON, a numerical entry box in which you can specify the Stop Phase opens.

The Stop Phase can be set at the Normal 1, Normal 2, and Abnormal steps. For other steps, the Stop Phase is fixed to OFF and cannot be specified.

■ Trigger output (Trig Out)

State output to CONTROL I/O connector. This specifies whether the trigger output presents when the step starts. Polarity and pulse width of the trigger output complies with the trigger output setting (see 4.3.5). At the Initial Step, the trigger output cannot be specified and thus no trigger is output.

■ Step sync code output (Code)

State output to CONTROL I/O connector. Code to output while the execution of the step, which is specified by 2-bit H/L. The step synchronization code can be specified also at the Initial Step.

■ Repeat (Repeat)

You can set to repeat the simulation in a series from the Normal 1 step to the Normal 2 step. Specify the ON or OFF of repeat and the repeat count. When Repeat is set to ON, the simulation repeats for the specified count. The simulation in a series is repeated for the repeat count + 1. Setting the repeat count to zero (0) means an infinite count. When Repeat is set to OFF, the DP020AGS executes the simulation only once and finishes it without performing the repeat operation.

4.3.3 Output Examples Using Simulation Function

■ Voltage dip simulation

In this simulation, the 50 Hz 100 V power source repeats a 70% voltage dip for 0.5 seconds three times at 10-second intervals as shown in *Figure 4-12*. For this case, set so that the total of Normal 1 and Normal 2 Step Times becomes 10 seconds and set the repeat count to 3. Set the Trans 1 and Trans 2 Step Times to zero (*Table 4-5*).

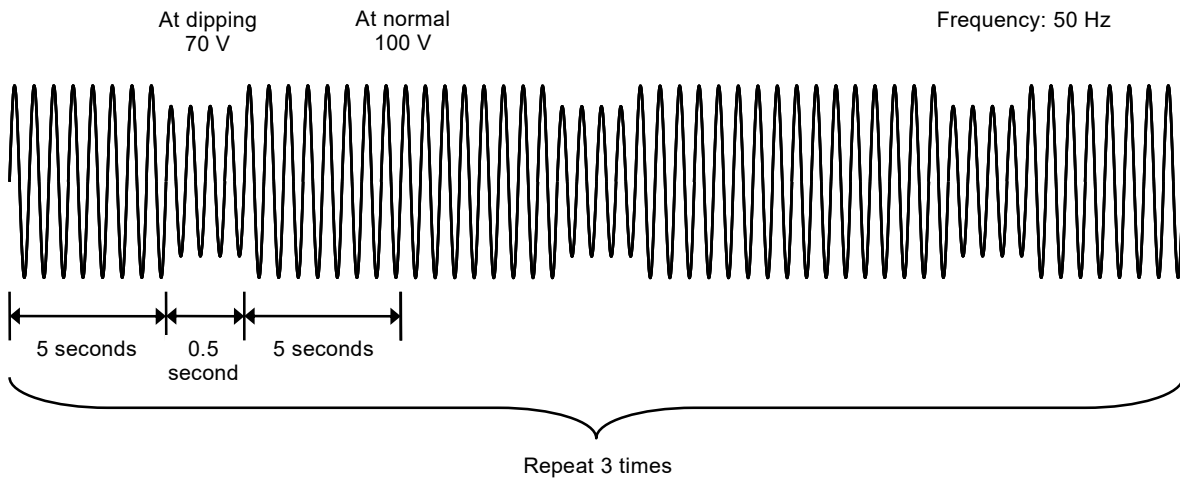

Figure 4-12 Voltage Dip Simulation Example

Table 4-5 Voltage Dip Simulation Edit Example

Step	Initial	Normal 1	Trans 1	Abnormal	Trans 2	Normal 2
Step Time	–	5 s	0 s	0.5 s	0 s	5 s
AC voltage	100 V	100 V	–	70 V	–	–
Frequency	50 Hz	50 Hz	–	50 Hz	–	–
Start Phase	OFF	OFF	–	OFF	–	OFF
Stop Phase	OFF	OFF	–	OFF	–	OFF
Repeat count	2 times					

■ Voltage change simulation

In this simulation, the 50 Hz 100 V power source repeats the voltage change three times at 10-second intervals, while the voltage drops to 70% and then linearly recovers in 0.5 seconds during one cycle as shown in *Figure 4-13*. For this case, set so that the total of Normal 1 and Normal 2 Step Times becomes 10 seconds and set the repeat count to 3. Set the Trans 1 Step Time to zero (Table 4-6).

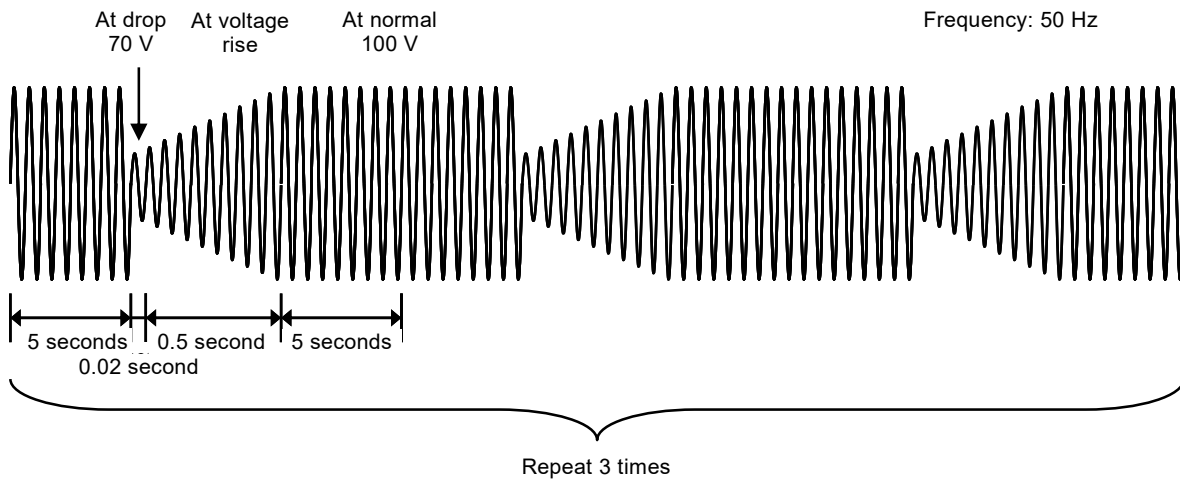

Figure 4-13 Voltage Change Simulation Example

Table 4-6 Voltage Change Simulation Edit Example

Step	Initial	Normal 1	Trans 1	Abnormal	Trans 2	Normal 2
Step Time	–	5 s	0 s	0.02 s	0.5 s	5 s
AC voltage	100 V	100 V	–	70 V	–	–
Frequency	50 Hz	50 Hz	–	50 Hz	–	–
Start Phase	OFF	OFF	–	OFF	–	OFF
Stop Phase	OFF	OFF	–	OFF	–	OFF
Repeat count	2 times					

4.3.4 Process Flow in a Step

Figure 4-14 shows the process flow in one step. The End operation causes the transition as shown in Figure 4-15.

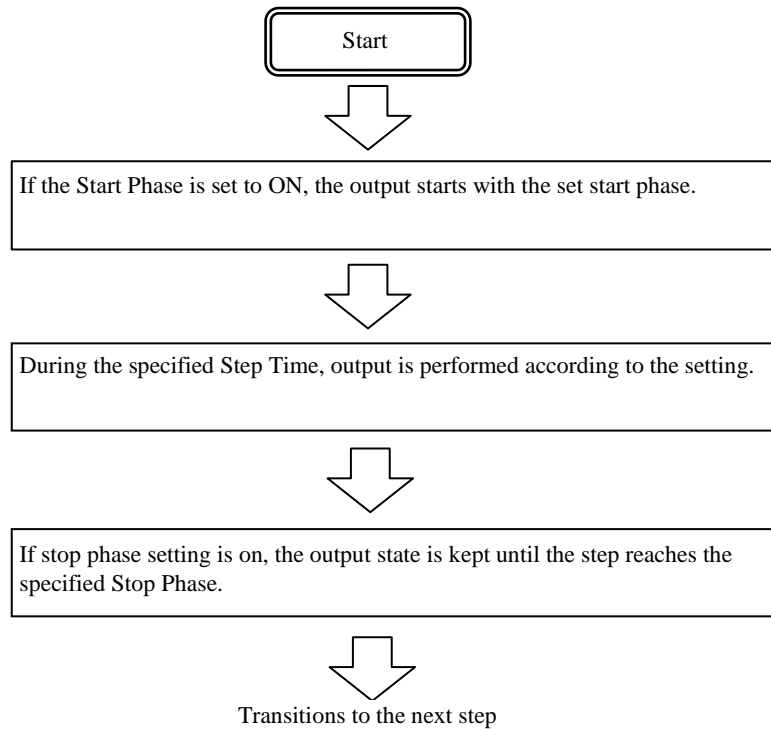

Figure 4-14 Process Flow through Simulation Steps

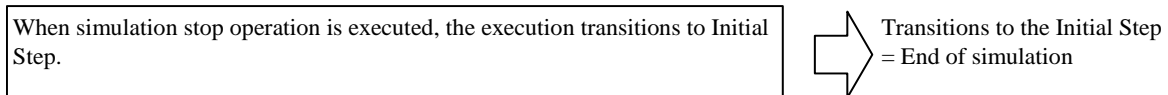

Figure 4-15 Stop Operation

4.3.5 Editing Simulation

----- Notes -----

- When the power is turned off, edited contents of the simulation are cleared, and all simulations have the default setting values when it is started next time. To keep the edited contents of simulation, save them in the Simulation Memory (see 4.3.9).
 - When a simulation is loaded from memory, the simulation you are editing is discarded.
 - You can also turn on output on the Simulation Edit View. At this point, output will be the value set in the initial step.
-

■ Transition to Simulation Edit View

Press the MENU key to open the root menu, then select [Simulation] (see 3.3.1). While the Simulation Control View is displayed, if you push the [Edit] soft-key, the execution transitions to the Simulation Edit View.

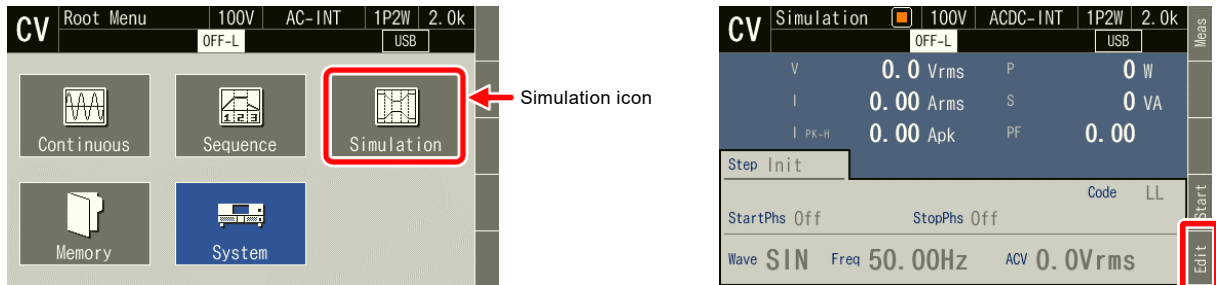

■ Creating (editing) a simulation

1. In the Simulation Edit View, press the [OSC] soft-key, and then select 100 V or 200 V range. In addition, specify On or Off for repeat and the repeat count in the [Repeat] item. To create a new simulation from an existing one, load the existing one (see 4.3.7).

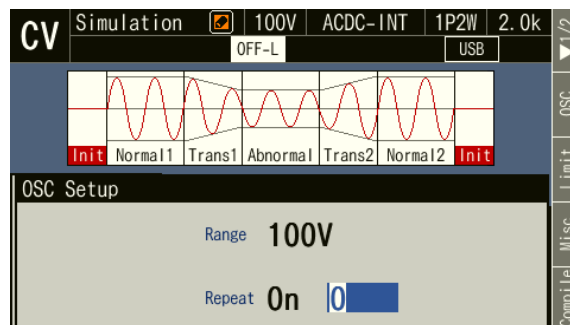

2. Set the parameter of each step. You can move between each step by changing [Step] item. Also, even if the cursor is not on the [Step No.] item, you can move to the previous step by pressing **PREV**, and to the next step by pressing **NEXT**. Also, you can move to the first step by pressing **SHIFT** + **PREV**, and last step by pressing **SHIFT** + **NEXT**.

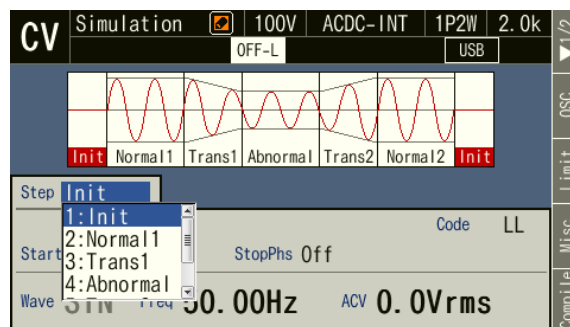

- Press the [Misc] soft-key to open the Misc Setup window. You can set the polarity and pulse width of the trigger output in [Trig Out]. You can select s or ms as the unit of Step Time in [TimeUnit].

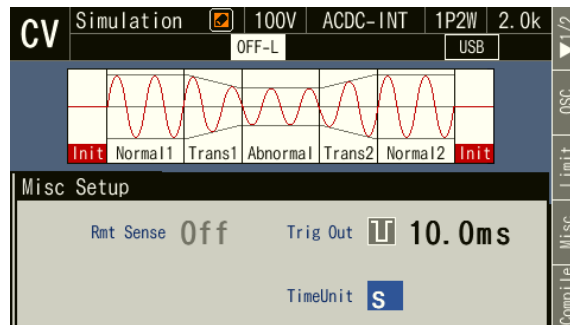

- Press [Clear] on soft-key page 2 to clear all the steps you are editing and return to the factory default settings.

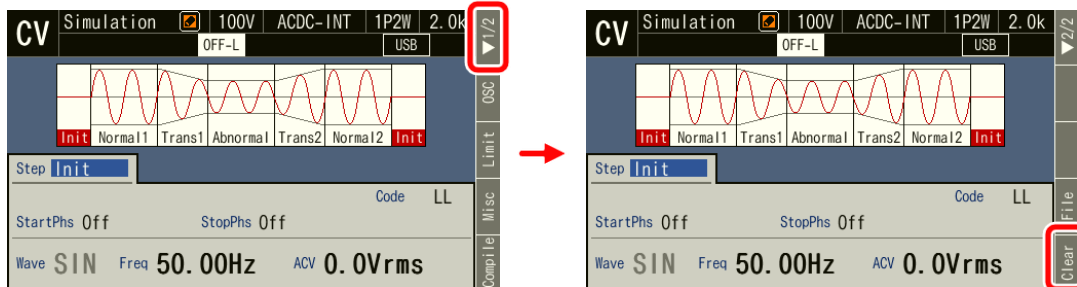

4.3.6 Opening Data List View of Simulation Memory

You can access this product's internal memory and USB memory to save, recall, clear, and rename simulations.

■ Displaying saved simulations

- In Simulation Edit View, select [File] on soft-key page 2. Simulation Memory View opens.

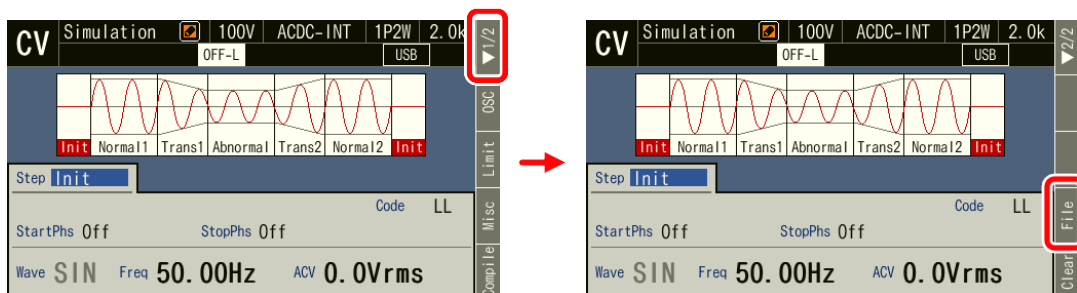

4. Advanced Operation

- The simulation memory data list appears. For the [Target] item, select the destination [1: System] (internal memory) or [2: USB] (USB memory).

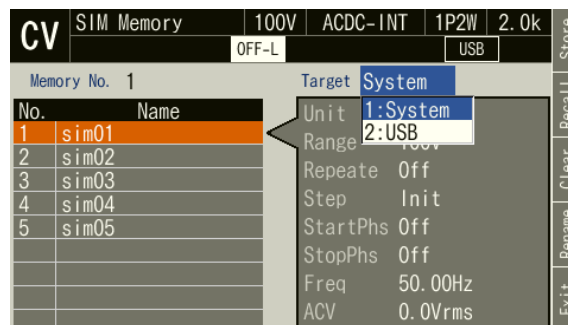

- Specify the memory number to reference in the [Memory No.] item. Even if the cursor is not on the [Memory No.] item, you can move to the previous number by pressing **PREV**, and to the next number by pressing **NEXT**. Also, you can move to the first number by pressing **SHIFT** + **PREV**, and last number by pressing **SHIFT** + **NEXT**.

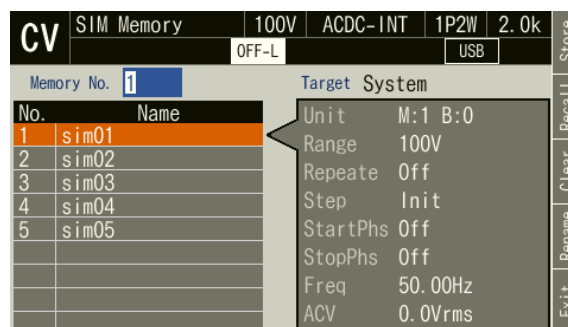

- If you push the [Exit] soft-key, the execution transitions back to the Simulation Edit View.

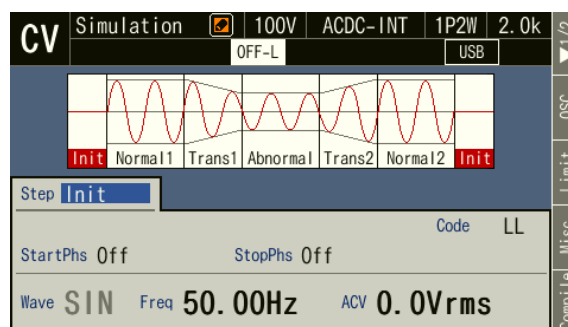

- Notes -----
- You can also open Simulation Memory View by pressing the menu key to move to the root menu and then selecting [Memory] → [Simulation Memory]. (see 4.7.4) In this case, pressing the [Exit] soft-key returns to Memory View.
-

4.3.7 Loading a Simulation

----- Notes -----

- When a simulation is loaded, the simulation you are editing is discarded.
- Simulation cannot be loaded in the Simulation Control View.
- For how to connect USB memory to this product, and how to disconnect from this product, see 4.8.
- The number of simulation data files saved in a USB memory should be 500 or less. If the number of files exceeds this limit, this product cannot recognize the simulation data files in the USB memory.

■ Recalling a saved simulation

1. Open Simulation Memory View (see 4.3.6). Select the [Target] and [Memory No.] items and specify the simulation to recall, then press the [Recall] soft-key.

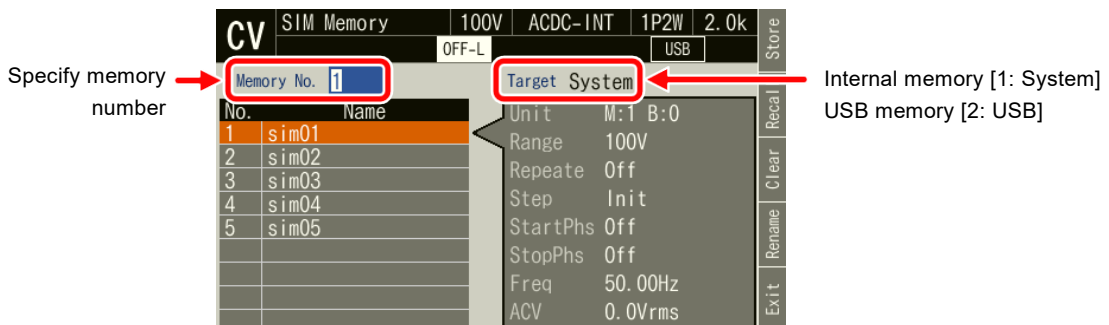

2. The confirmation window for loading the simulation opens. Select [OK]. The simulation with the specified memory number is loaded.

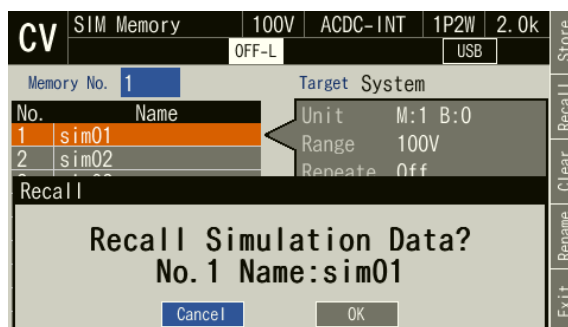

4.3.8 Executing Simulation

The edited simulation can be executed after converted to executable program by compile operation.

■ Transition to Simulation Edit View

When pushing [Compile] soft-key in the Simulation Edit View, the edited power fluctuation is compiled, and then the screen transitions to Simulation Control View.

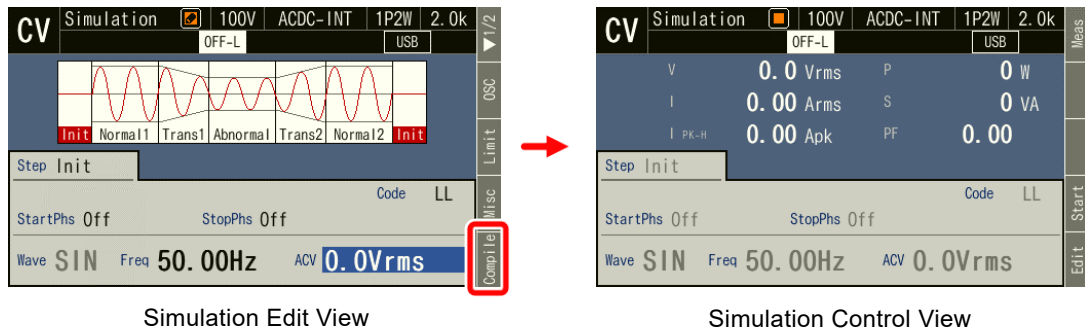



- Notes -----
- If an improper setting is detected during compilation, an error message is displayed and the screen does not transition to the Simulation Control View.
-

■ Starting/ending a simulation

1. If output is turned off in the Simulation Edit View, the Power Fluctuation Test can be executed when output is turned on in the Simulation Control View.

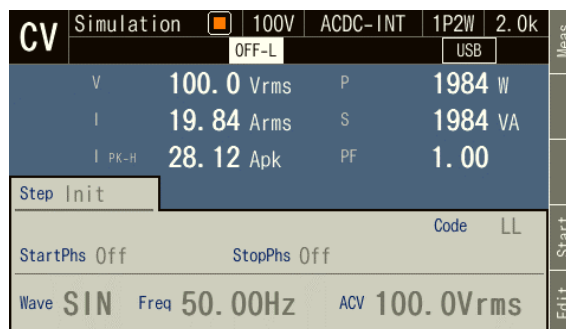
When a simulation is stopped, the icon  is displayed.



- Press the [Start] soft-key to start the simulation. While the simulation is executed, the icon  is displayed.

CV	Simulation		100V	ACDC-INT	1P2W	2.0k	Meas	
			OFF-L		USB			
	V	70.0	Vrms	P	972	W	Stop	
	I	13.89	Arms	S	972	VA		
	I _{PK-H}	28.13	Apk	PF	1.00			
	Step	Abnormal						Start
	Time	10.0000s				Code	LL	
	StartPhs	Off	StopPhs	Off	TrigOut	Off		
	Wave	SIN	Freq	50.00Hz	ACV	70.0Vrms	Edit	

- When [Stop] soft-key is pushed while simulation is executed, the execution transitions to the output that is set in the Initial Step, and then simulation is terminated.

CV	Simulation		100V	ACDC-INT	1P2W	2.0k	Meas	
			OFF-L		USB			
	V	100.0	Vrms	P	1984	W	Stop	
	I	19.84	Arms	S	1984	VA		
	I _{PK-H}	28.12	Apk	PF	1.00			
	Step	Init						Start
	Time					Code	LL	
	StartPhs	Off	StopPhs	Off	TrigOut	Off		
	Wave	SIN	Freq	50.00Hz	ACV	100.0Vrms	Edit	

Notes

- In the output off state, the simulation cannot be started.
- The output on/off phase setting is invalid for the Simulation.

■ Returning to Simulation Edit View

If you push the [Edit] soft-key, the execution transitions back to the Simulation Edit View.

CV	Simulation		100V	ACDC-INT	1P2W	2.0k	Meas	
			OFF-L		USB			
	V	100.0	Vrms	P	1984	W	Stop	
	I	19.84	Arms	S	1984	VA		
	I _{PK-H}	28.12	Apk	PF	1.00			
	Step	Init						Start
	Time					Code	LL	
	StartPhs	Off	StopPhs	Off	TrigOut	Off		
	Wave	SIN	Freq	50.00Hz	ACV	100.0Vrms	Edit	

4.3.9 Saving Simulation

----- Notes -----

- Simulation cannot be saved in the Simulation Control View.

■ Saving the simulation in the internal memory

1. Open Simulation Memory View (see 4.3.6). Select the [Target] and [Memory No.] items and specify the simulation to save, then press the [Store] soft-key.



2. A window to confirm saving opens. Select [OK].

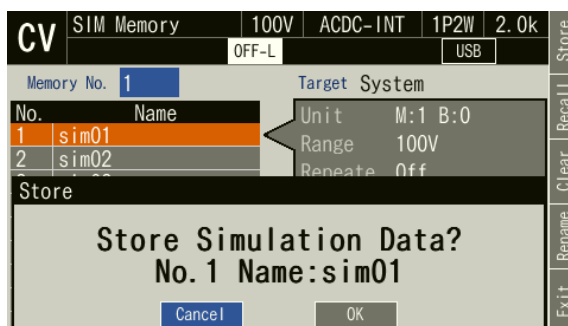

■ Saving the simulation in the USB memory

For how to connect USB memory to this product, and how to disconnect from this product, see 4.8.

1. Open Simulation Memory View (see 4.3.6). Select the [Target] and [Memory No.] items and specify the simulation to save, then press the [Store] soft-key. When saving a new simulation, specify a number for which [Name] is blank in the data list.

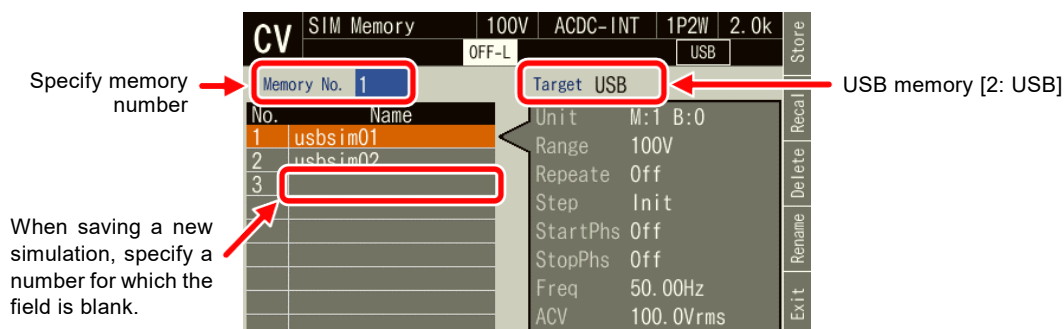

- When overwriting a simulation, a window to confirm saving opens. Select [OK]. When saving a new simulation, a window to enter the name for saving opens. Enter the name, and then select [OK]. For how to enter a string, see 3.3.6.

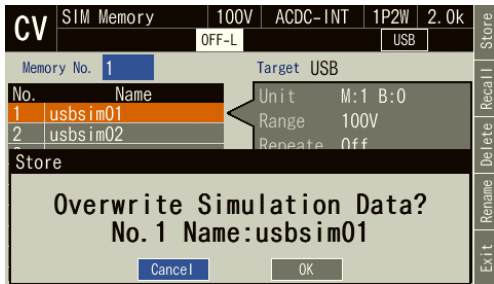

Confirmation window
(when overwriting a simulation)

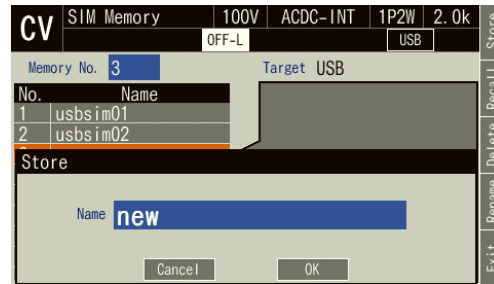

Confirmation window
(when saving a new simulation)

- Notes -----
- The number of simulation data files saved in a USB memory should be 500 or less. If the number of files exceeds this limit, this product cannot recognize the simulation data files in the USB memory.
-

4.3.10 Clear/Rename Simulation

■ Clearing/renaming a simulation saved in internal memory

- Open Simulation Memory View (see 4.3.6). Select the [Target] and [Memory No.] items and specify the simulation to clear or rename.

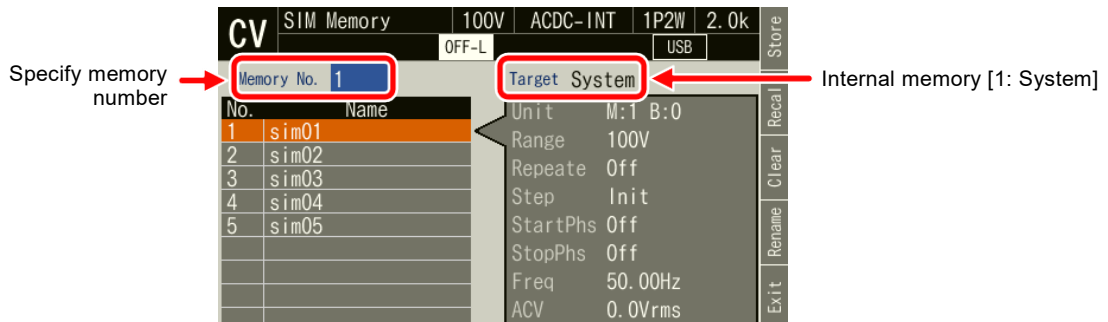

4. Advanced Operation

2. To clear, push [Clear] soft-key. Confirmation message is displayed. Select [OK]. In the cleared number of the memory, the simulation data at factory shipment is stored.

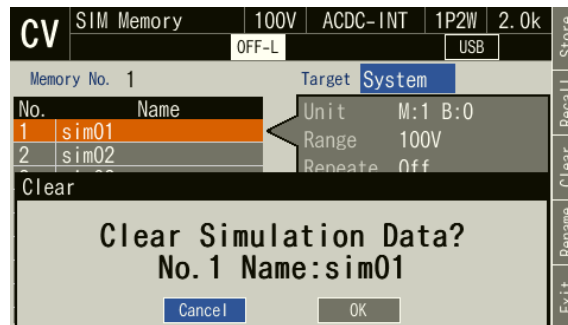

3. To rename, push [Rename] soft-key. Rename window opens. Enter a new name and then select [OK]. For how to enter a string, see 3.3.6.

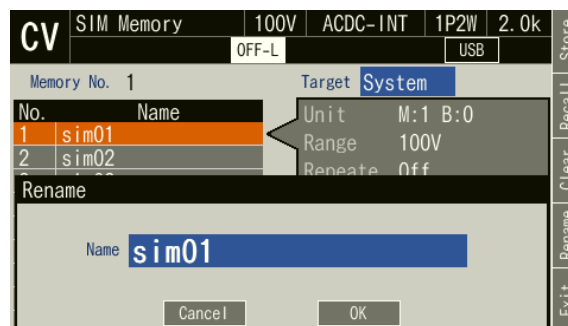

■ Erasing/renameing a simulation saved in USB memory

For how to connect USB memory to this product, and how to disconnect from this product, see 4.8.

1. Open Simulation Memory View (see 4.3.6). Select the [Target] and [Memory No.] items and specify the simulation to recall.

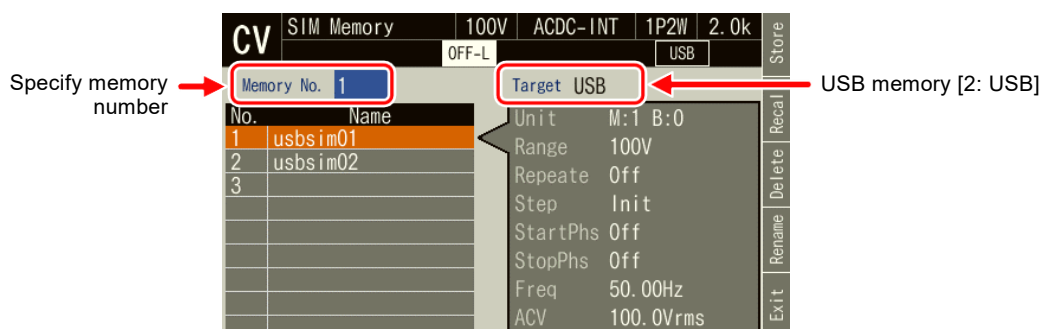

- To clear, push [Delete] soft-key. Confirmation message is displayed. Select [OK]. The corresponding file in USB memory is deleted.

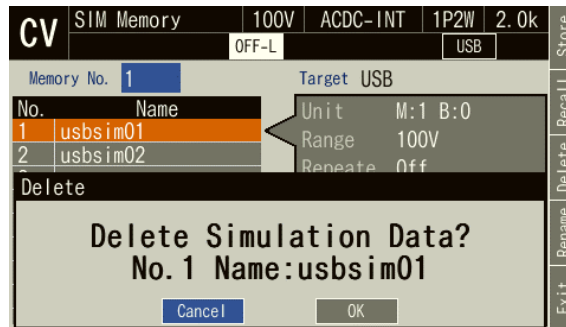

- To rename, push [Rename] soft-key. Rename window opens. Enter a new name and then select [OK]. For how to enter a string, see 3.3.6.

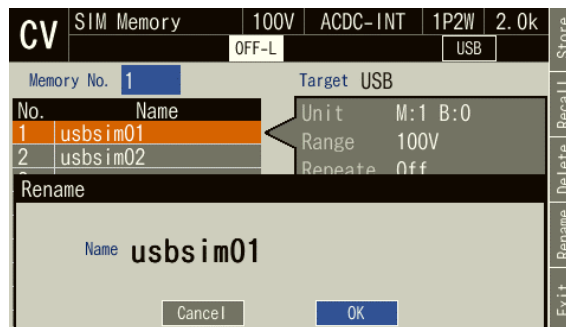

4.3.11 Set so as the Simulation Function is Selected at Power-on

You can set so as the Simulation function is selected at power-on.

■ Operation procedure

- Press the MENU key to move to the root menu, and then select [System]. The system setting window opens.

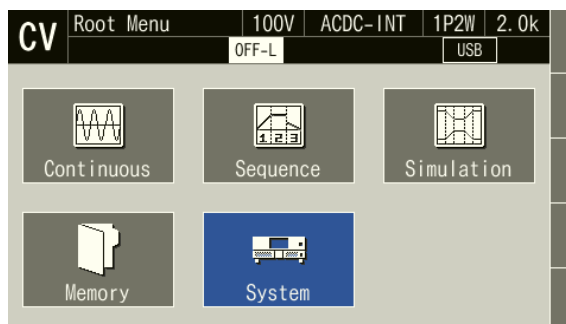

- In [PwOn Mode] item, select [3:Sim].

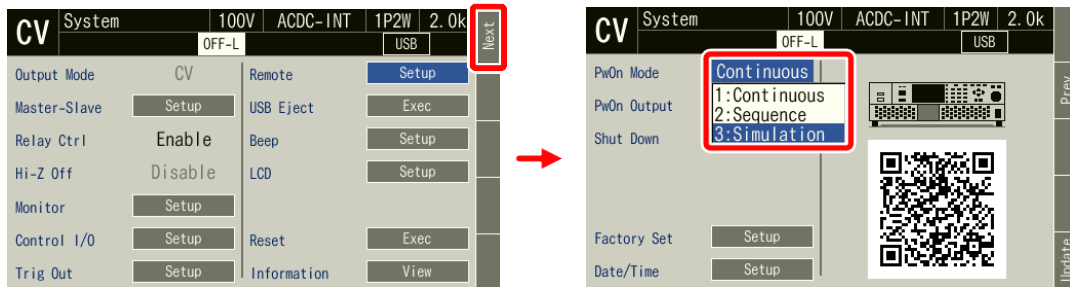

Notes

- To set so as to Continuous function is selected at power-on, select [1:Continuous] in [PwOn Mode] item.

4.3.12 Simulation Control by CONTROL I/O

CONTROL I/O enables to start/stop a simulation and to recall the memory. For details, see 4.18.

4.3.13 Screen Overview

The Simulation function screen is broadly divided to the Simulation Edit View and the Simulation Control View. The Simulation Edit View opens when you select the power fluctuation testing (Simulation) icon from the root menu. After pushing [Compile] soft-key in Simulation Edit View, the screen transitions to the Simulation Control View.

Notes

- You cannot transition to root menu by pushing the MENU key in the Simulation Control View. To transition to the root menu, first move to the Simulation Edit View and then push the MENU key.

■ Simulation Edit View

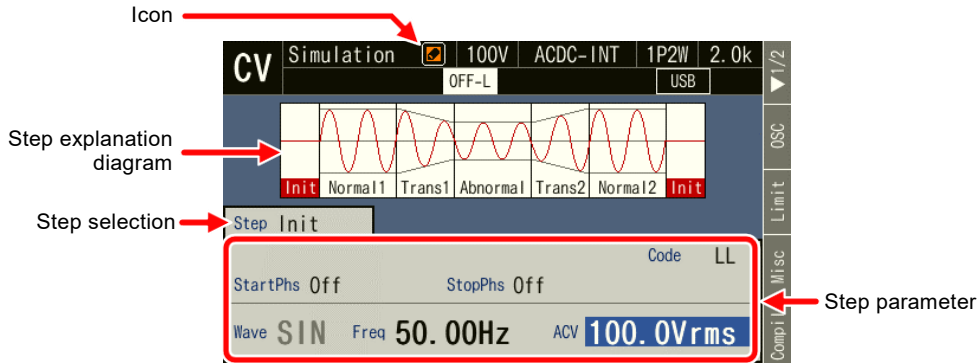

Figure 4-16 Simulation Edit View

■ Simulation Control View (output off state, simulation stopped)

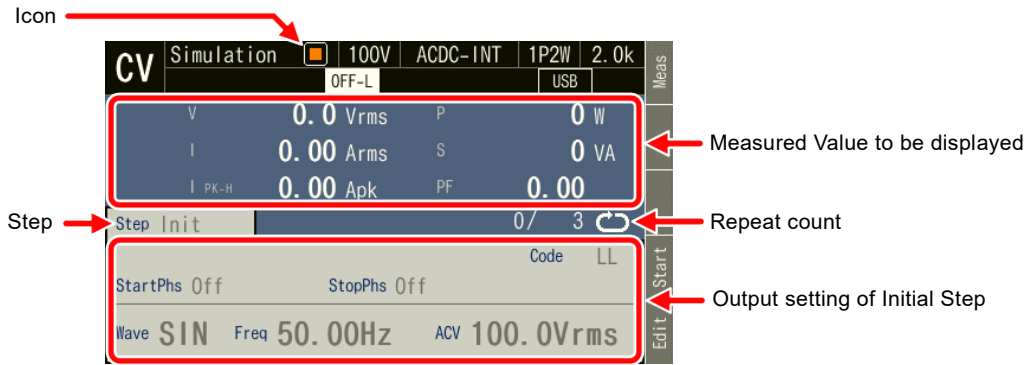

Figure 4-17 Simulation Control View (Output Off State, Simulation Stopped)

■ Simulation Control View (output on state, simulation running)

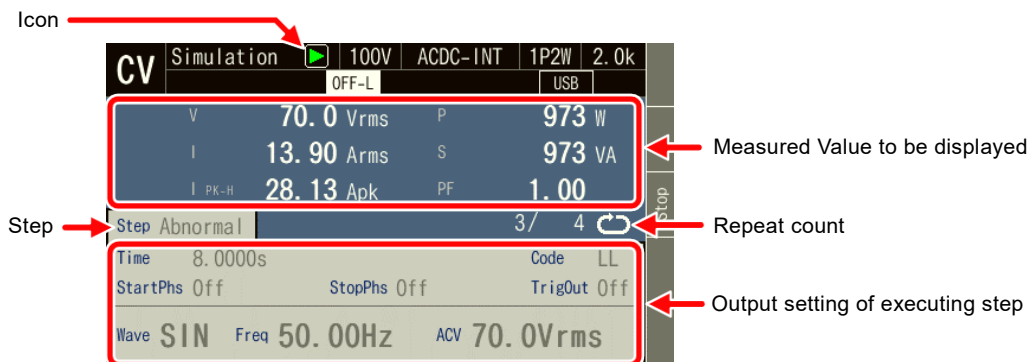

Figure 4-18 Simulation Control View (Output On State, Simulation Running)

■ Simulation Control View (output on state, simulation stopped)

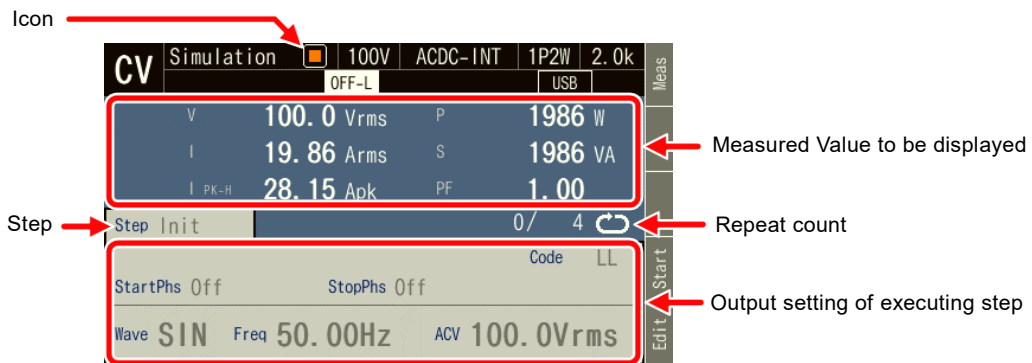

Figure 4-19 Simulation Control View (Output On State, Simulation Stopped)

4.4 Measuring Harmonic Current

Some electric devices of AC power input have its input current waveform greatly distorted from the sine wave. For example, when the power input section uses a capacitor input type rectifier circuit, the input current is generally distorted as shown in *Figure 4-20 Current Waveform Containing Many*. A waveform distorted like this contains many harmonic components. If a current with many harmonic components is supplied to the power line in high volume, the line voltage is distorted, causing problems such as malfunction of devices and overheated transformer which may result in accidents.

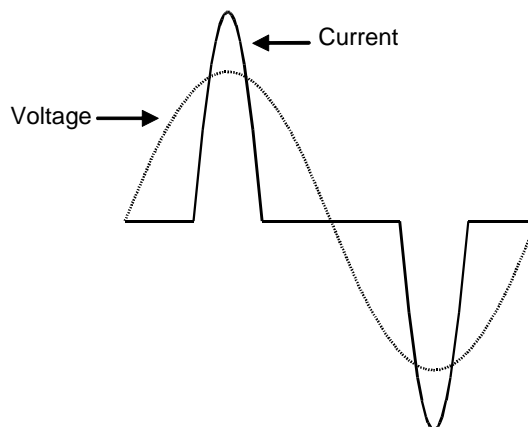

Figure 4-20 Current Waveform Containing Many Harmonic Components

4.4.1 Harmonic current

The components contained in output voltage and output current can be measured.

The harmonic current measurement function is available only for the Continuous function, AC-INT, and set frequency of 40 Hz to 550 Hz.

The maximum frequency that can be analyzed is 5000 Hz. The upper limit of the analysis order varies depending on the frequency of the fundamental wave. The components are displayed as an RMS and a percentage in respect to the fundamental wave component.

----- Notes -----

- The Harmonic current measurement function does not support the standard tests defined by organizations such as IEC. Use this function for a preliminary testing.

4.4.2 Measured Value Display Method

■ Operation procedure

1. In the Continuous function, select the [Measure] soft-key, put the cursor on [View] of the [Harmonic] item, and press the ENTER key.

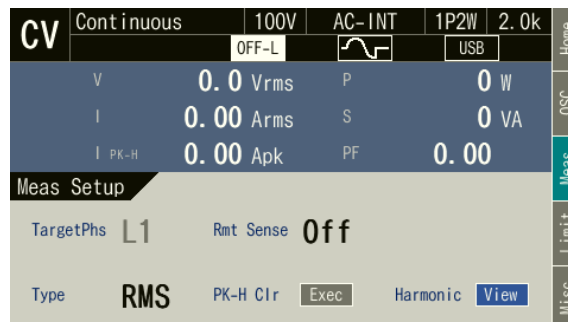

2. The view opens populated with the measured harmonic components of orders 1 to 10 on the left side and orders 11 to 20 on the right side.

CV		Harmonic View	100V	AC-INT	1P2W	2.0k
		OFF-L			USB	
L1	I (rms)	nth/1st		I (rms)	nth/1st	
1st	14.67A	100.0%		11th	0.47A	3.2%
2nd	0.00A	0.0%		12th	0.00A	0.0%
3rd	1.60A	10.9%		13th	0.38A	2.6%
4th	0.00A	0.0%		14th	0.00A	0.0%
5th	1.32A	9.0%		15th	0.38A	2.6%
6th	0.00A	0.0%		16th	0.00A	0.0%
7th	1.00A	6.8%		17th	0.37A	2.5%
8th	0.00A	0.0%		18th	0.00A	0.0%
9th	0.70A	4.8%		19th	0.33A	2.2%
10th	0.00A	0.0%		20th	0.00A	0.0%

Note: The view is when in CV mode.

In CC mode, the view will be harmonic voltage measurement values.

- Press the [Next] soft-key to switch to the view populated with the measured values for orders 11 to 20 on the left side and orders 21 to 30 on the right side. Press the [Prev] soft-key to return to the original view. Switch the view in the same manner for the measured values over order 21.

CV	Harmonic View		100V	AC-INT	1P2W	2.0k	next
	OFF-L				USB		
L1	I (rms)	nth/1st		I (rms)	nth/1st		Volt Prev Exit
11th	0.47A	3.2%	21st	0.28A	1.9%		
12th	0.00A	0.0%	22nd	0.00A	0.0%		
13th	0.38A	2.6%	23rd	0.25A	1.7%		
14th	0.00A	0.0%	24th	0.00A	0.0%		
15th	0.38A	2.6%	25th	0.24A	1.7%		
16th	0.00A	0.0%	26th	0.00A	0.0%		
17th	0.37A	2.5%	27th	0.25A	1.7%		
18th	0.00A	0.0%	28th	0.00A	0.0%		
19th	0.33A	2.2%	29th	0.23A	1.6%		
20th	0.00A	0.0%	30th	0.00A	0.0%		

- Press the [Volt] soft-key or [Curr] soft-key to switch to harmonic voltage or harmonic current.
- Press the CANCEL key or [Exit] soft-key to return to the Continuous function view.

4.5 Measuring Inrush Current

4.5.1 Inrush Current

On an electric device using a capacitor input type rectifier circuit for power input, an excessive current in comparison to the Normal state may flow for a short period of time immediately after the start of power supply. This current is called inrush current. If such a big current flows to the power line, the supply voltage may drop due to the impedance of the power line. Therefore, the inrush current is restricted below a certain level in some standards.

Figure 4-21 shows the inrush current waveform of a small electric drill. The inrush current flows at 14 A peak, which is about four times of the rated current of 3.5 A.

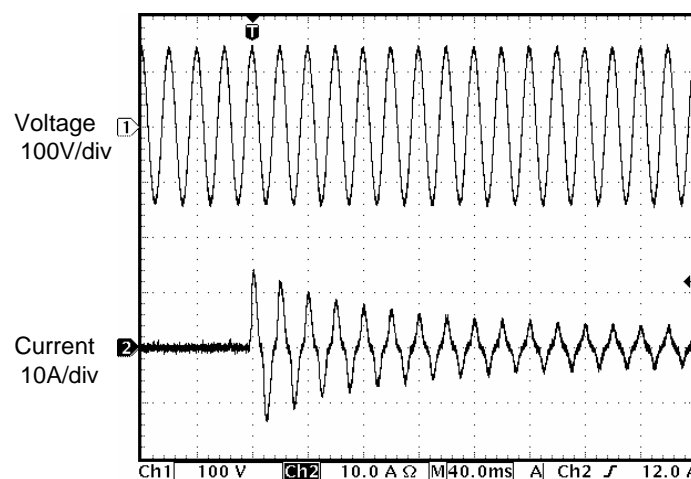

Figure 4-21 Inrush Current Example

It is necessary for an electric device with a large inrush current to use a power source with a sufficient current supplying capability. With a power source that cannot supply a sufficient inrush current, some electric devices may not start as they are not supplied with necessary power.

This product has the ability to supply peak current up to four times of the RMS rating. You can measure the maximum inrush current value using the current peak-hold function of the product.

4.5.2 Peak-hold function

- A current peak hold function is available in CV mode, and a voltage peak hold function in CC mode.
- Peak-hold function holds either a positive or negative peak value, whichever is larger in absolute value.
- Clearing function for the peak-hold value is provided. The clear operation clears the peak-hold value (all phases) to 0 Apk.

----- Notes -----

- The peak hold value starts to update again immediately after the clear operation. The clear operation may not turn the current peak-hold value to 0 Apk even when no current is being output, because of noise or other reasons.

4.5.3 Measurement Method

■ Operation procedure

1. Before turning on the output, clear the peak-hold value. Following two methods are available.
 - (a) Shortcut operation: **SHIFT** + **+/-**
 - (b) Push the [Measure] soft-key. Hover the cursor over [Exec] of the [PK-H Clr] item and press the ENTER key.

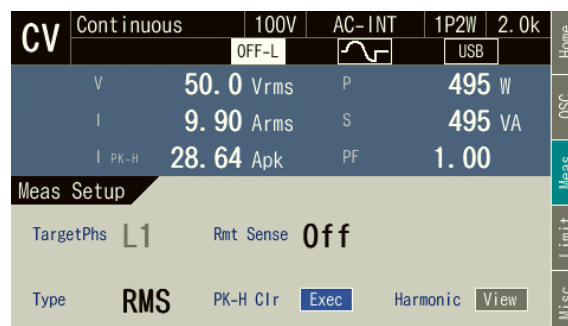

2. Turn on the power switch of the object to be measured.
3. Turn on the output.
4. Read current peak-hold value (I_{PK-H}). This is the maximum inrush current value.

4.5.4 Measurement Tips

- In CV mode, you can see the difference among inrush currents at each power-on phase by changing the phase setting at output on (see 3.6.9) before turning on the output.
- The object inrush current cannot be measured correctly when the maximum peak voltage/current exceeds the one that can be supplied by this product or the peak voltage/current limiter is activated.
- In CV mode, the correct peak value measurement may not be accomplished for a very small load impedance, such as when there is a short at the output terminal.

4.6 Using Clipped Sine Wave

This function can be used in CV mode only.

Clipped sine wave is the waveform that has its sine wave peak clipped as shown in *Figure 4-22*. This product can select the clipped sine wave as the output waveform.

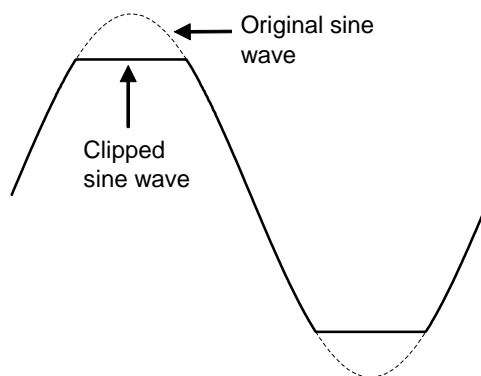

Figure 4-22 Clipped Sine Wave

The depth of clip is set using the crest factor or clip ratio. Each of them is defined by the following expression. The clip ratio is set in percentage.

$$\text{Crest factor} = \text{Peak value/RMS value}$$

$$\text{Clip ratio} = \text{Clipped sine wave peak value/Original sine wave peak value}$$

As shown in *Table 4-7*, the output voltage setting method differs depending on the clip depth setting method. Therefore, a clip ratio less than 100% makes the output voltage smaller than the setting.

Table 4-7 Different Output Voltage Settings Depending on Clip Depth Setting Method

Clip Depth Setting Method	Output Voltage Setting Method
Crest factor	Sets the RMS of the clipped waveform
Clip ratio	Sets the RMS of the sine wave before clipping

Notes

- When the clipped sine wave is output in the AC, the clip of the output waveform may be tilted by the DC component remove function in the AC. To avoid this, switch to the ACDC.

■ Operation procedure

- In the [Wave] item, select [CLP].

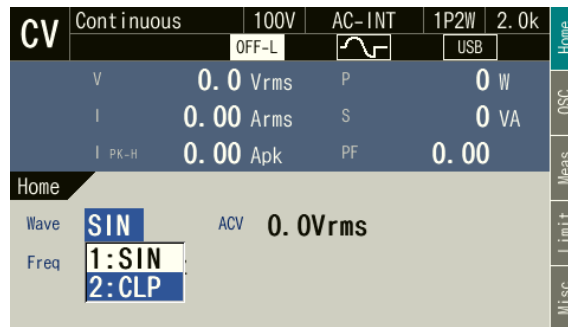

- Move the cursor to [Setup], then select it. The clipped sine wave setting window opens.

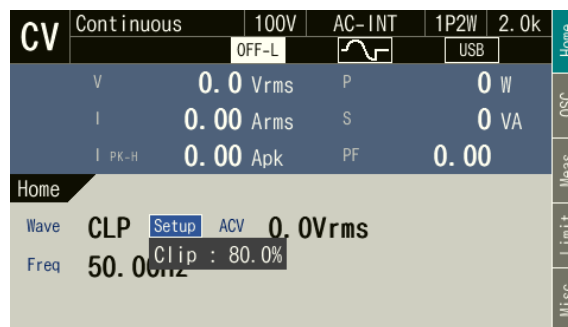

- In the [No.] item, select the clipped sine wave to load.

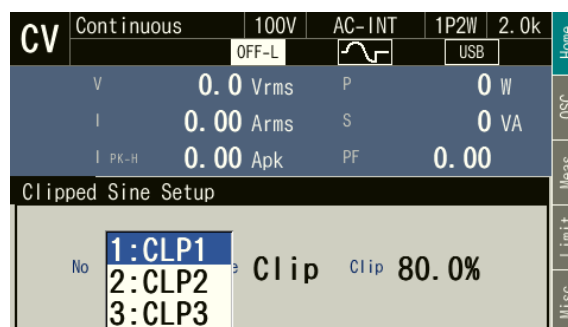

4. In the [Type] item, select [1: Clip] (clip ratio) or [2: CF] (crest factor).

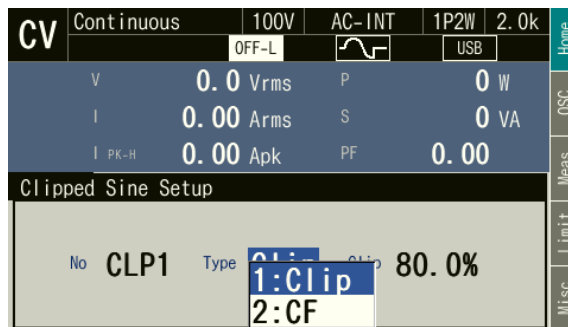

5. In the [CF] (or [Clip]) item, enter the crest factor (or clip ratio).

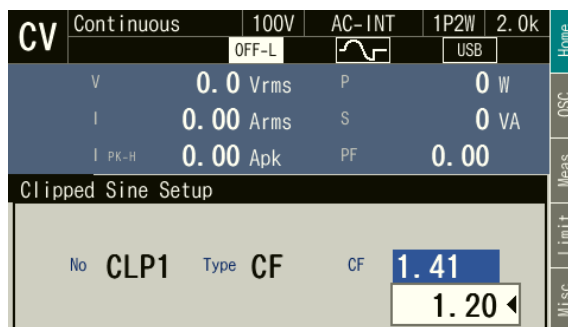

6. Press the CANCEL key. The clipped sine wave setting window closes.

- Notes -----
- All the settings from CLP1 to CLP3 are saved into the internal memory.
 - The clip ratio setting value and the crest factor setting value are held independently of each other. The setting value switch as the Type is changed. Each setting value is saved per waveform when the settings are saved into the internal memory.
-

4.7 Using Memory Function

Using the Memory function, you can access this product's internal memory and USB memory to save, load, clear, and rename the basic setting, sequence, and simulation.

4.7.1 Basic Setting Memory

The Basic Setting Memory collectively stores the output-related settings in the Continuous function (e.g. AC/DC mode, signal source, output range, AC setting, DC setting, current limiter, setting range limit). User is required to perform some operations to save these settings into the Basic Setting Memory. Both the internal and USB memories can be selected as the Basic Setting Memory.

There are 31 internal Basic Setting Memories for each output phase configuration from No. 0 to No. 30. The memory No. 0 stores the factory defaults. The internal memory No. 1 settings are loaded at power-on of this product. User can save the settings to the memories from No. 1 to No. 30. Clearing a Basic Setting Memory resets it to the factory defaults (same as the one of No. 0). Clearing a Basic Setting Memory in the USB memory deletes the applicable file in the USB memory.

For the set content saved in the Basic Setting Memory and factory defaults, see 10.27.

----- Notes -----

- The Basic Setting Memory content cannot be copied directly between the internal and USB memories. To copy them, load them first, then save to a new destination.
- No overwrite confirmation message is displayed when you attempt to save under the same name as for the data that exists on the USB memory.
- The number of basic setting data files saved in a USB memory should be 500 or less. If the number of files exceeds this limit, this product cannot recognize the basic setting data files in the USB memory.

4.7.2 Displaying Data List View of Basic Setting Memory

■ Operation procedure

1. Select [Memory] from the root memory.

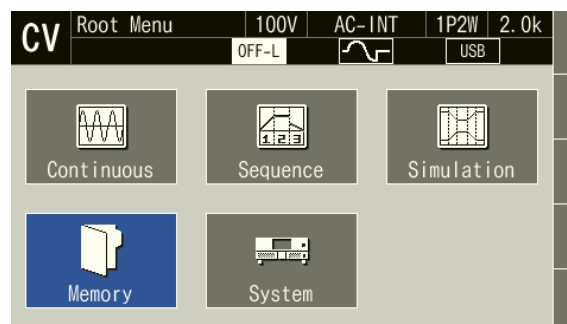

2. Displays the Memory View. Select [Setting Memory].

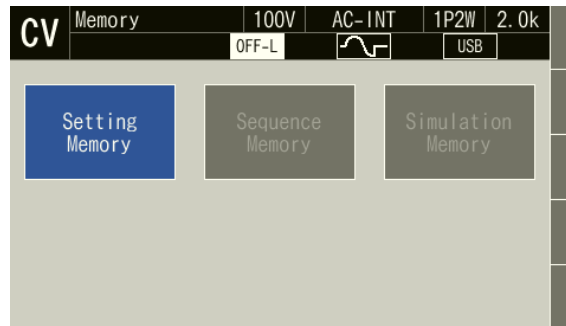

3. The Basic Setting Memory data list appears. Select reference target [1: System] (internal memory) / [2: USB] (USB memory) in the [Target] item.

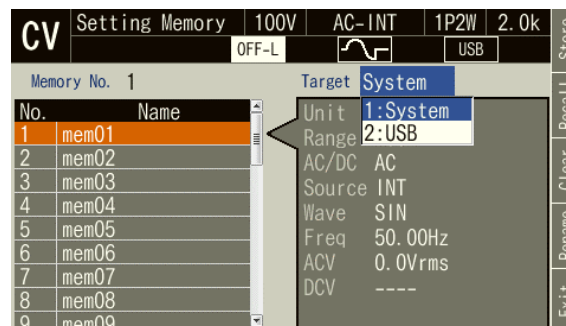

4. Specify the memory number to reference in the [Memory No.] item. Even if the cursor is not on the [Memory No.] item, you can move to the previous number by pressing **PREV**, and to the next number by pressing **NEXT**.

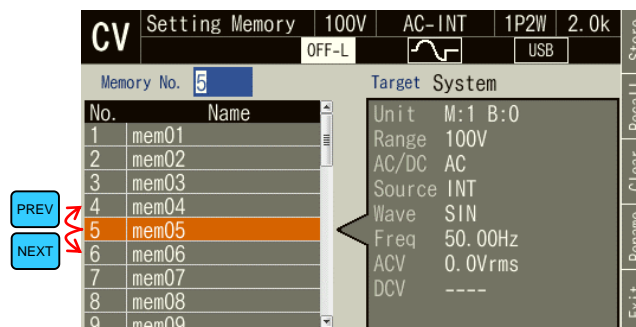

5. Press the [Exit] soft-key to return to Memory View.

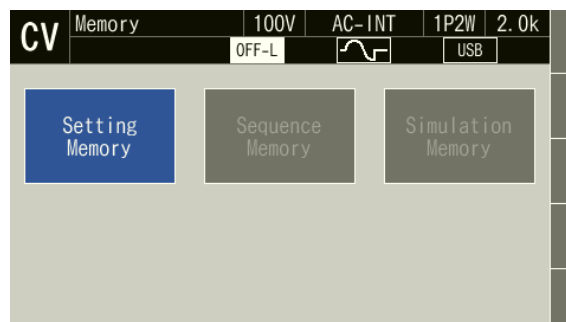

4.7.3 Saving, Recalling, and Clearing/Renaming of Basic Setting Memory

You can save the settings for the output of the Continuous function to internal memory or USB memory.

■ Saving basic settings to internal memory

1. Open Basic Setting Memory View (see 4.7.2). Select the [Target] and [Memory No.] items and specify the memory to save, then press the [Store] soft-key. When saving a new setting data, specify a number for which [Name] is blank in the data list.

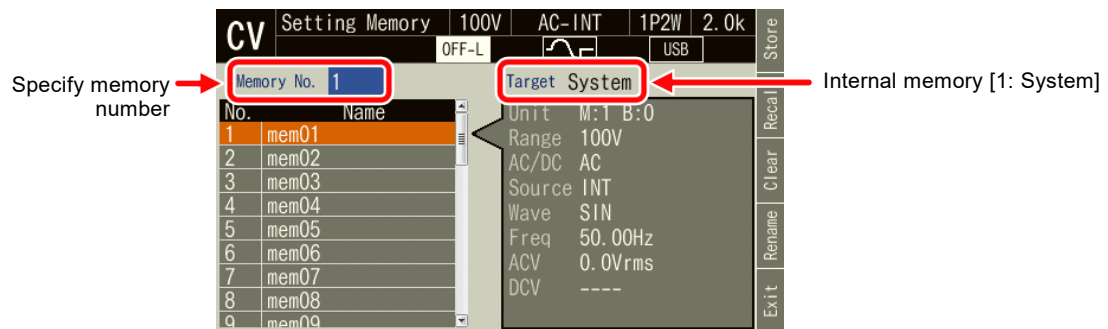

2. A window to confirm saving opens. Select [OK].

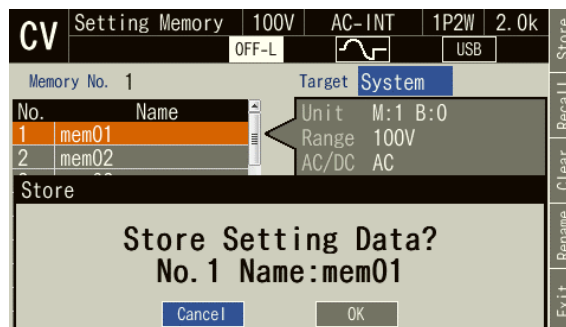

■ Saving basic settings to USB memory

For how to connect USB Memory to this product, and how to disconnect from this product, see 4.8.

1. Open Basic Setting Memory View (see 4.7.2). Push the [Store] soft-key. When saving a new setting data, specify a number for which [Name] is blank in the data list.

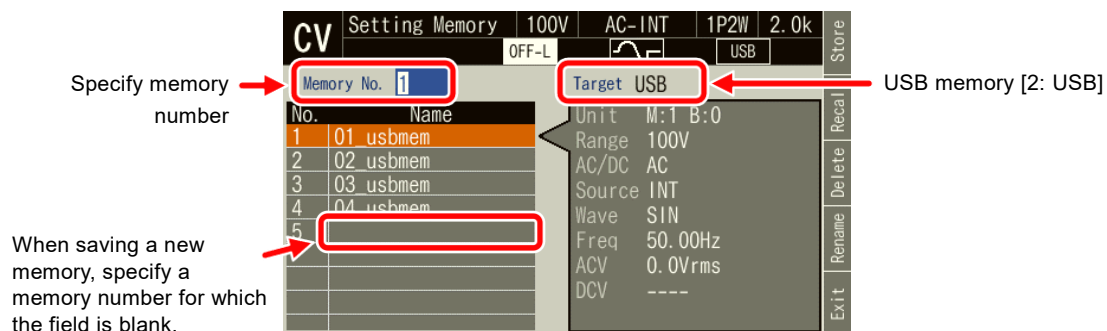

4. Advanced Operation

- When overwriting a memory, a window to confirm saving opens. Select [OK]. When saving a new setting data, a window to enter the name for saving opens. Enter the name, and then select [OK]. For how to enter a string, see 3.3.6.

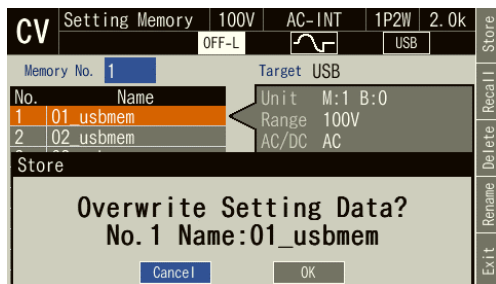

Confirmation window
(when overwriting a setting data)

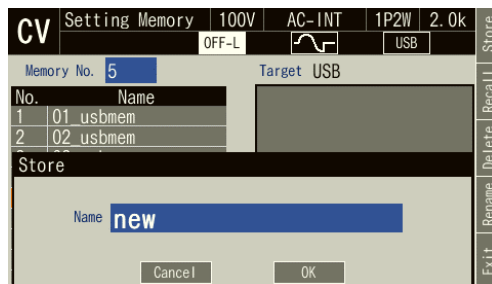

Confirmation window
(when saving a new setting data)

■ Recalling Basic Setting Memory by using a shortcut (RECALL key)

The Basic Setting Memory of memory numbers 1 to 9 saved in internal memory can be recalled by pressing shortcut keys **RECALL** + **1** to **9**.

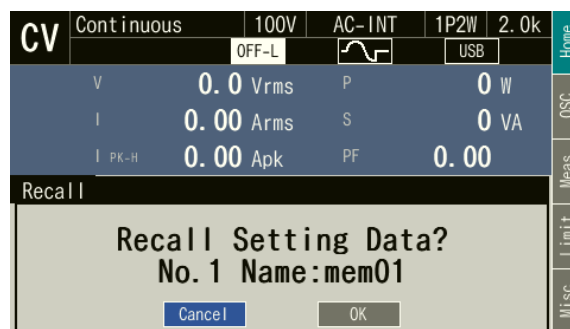

----- Notes -----

- The operation can be performed from the Continuous View.
- You do not have to hold down the RECALL key while you press a key of the numeric keypad.

■ Recalling from Data List View of Basic Setting Memory

- Open Basic Setting Memory View (see 4.7.2). Select the [Target] and [Memory No.] items and specify the memory to recall, then press the [Recall] soft-key.

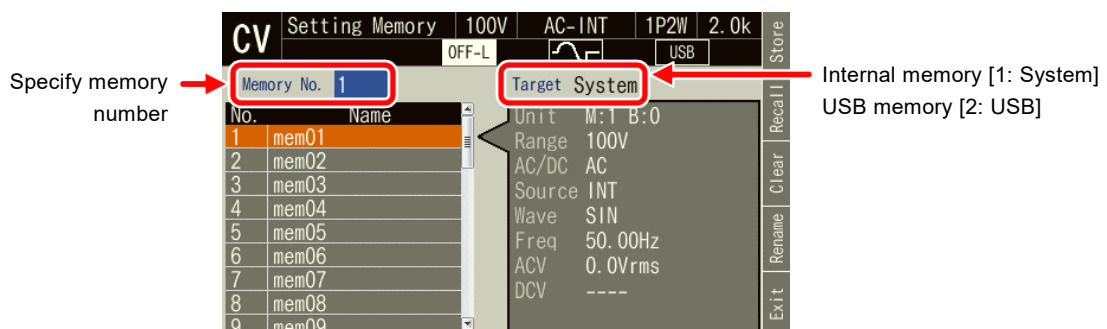

- The confirmation window for recalling opens. Select [OK]. The Basic Setting Memory with the specified number is recalled.

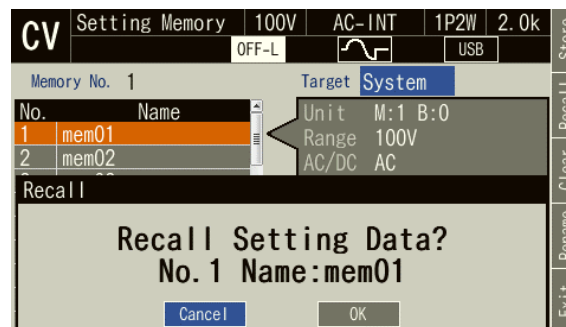

■ Clearing/rename Basic Setting Memory saved in internal memory

- Open Basic Setting Memory View (see 4.7.2). Select the [Target] and [Memory No.] items and specify the memory to clear or rename.

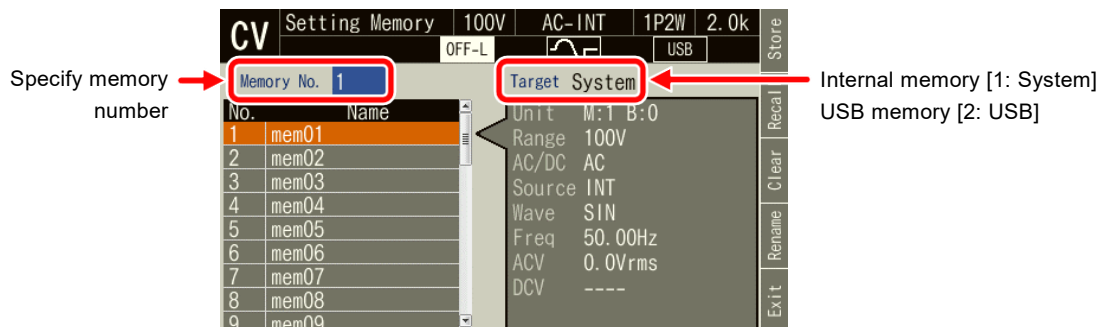

- To clear, push [Clear] soft-key. Confirmation message is displayed. Select [OK]. Clearing the internal memory resets the data to the factory default (same as the one of the internal memory No. 0).

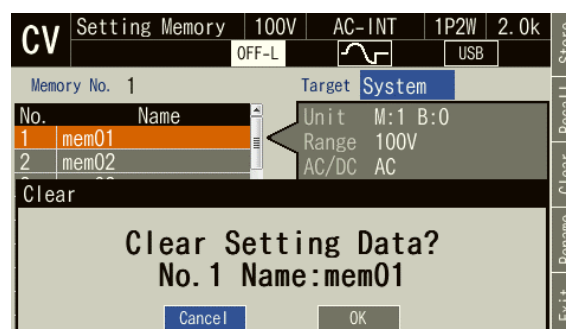

4. Advanced Operation

- To rename, push [Rename] soft-key. Rename window opens. Enter a new name and then select [OK].
For how to enter a string, see 3.3.6.

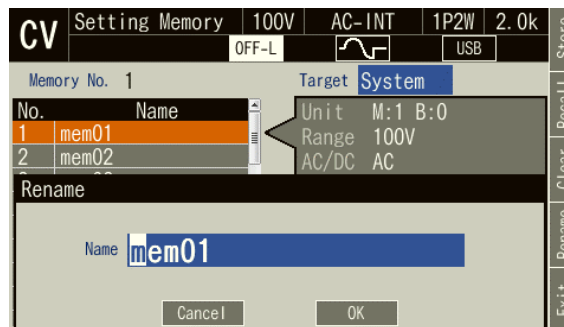

■ Clearing/rename Basic Setting Memory saved in USB memory

- Open Basic Setting Memory View (see 4.7.2). Select the [Target] and [Memory No.] items and specify the simulation to clear or rename.

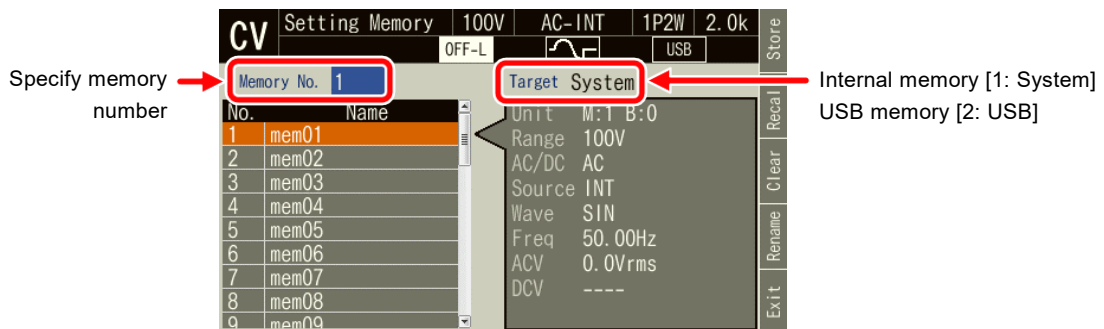

- To clear, push [Delete] soft-key. Confirmation message is displayed. Select [OK]. The corresponding file in USB memory is deleted.

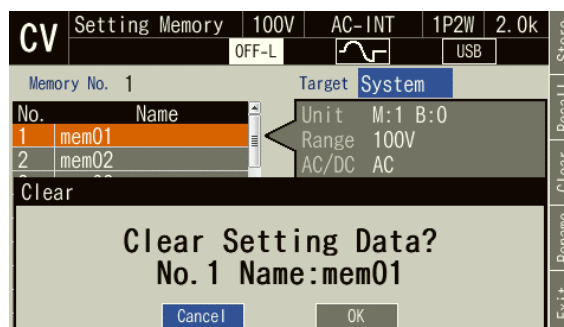

3. To rename, push [Rename] soft-key. Rename window opens. Enter a new name and then select [OK].
For how to enter a string, see 3.3.6.

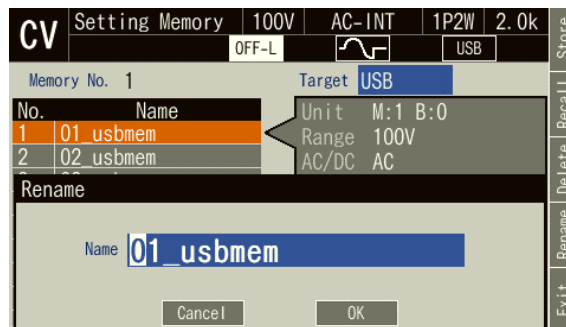

■ Loading the factory defaults

Press **RECALL** + **0** in the Continuous View. Confirmation message is displayed. Select [OK].
The current settings are cleared and the factory default basic settings are loaded.

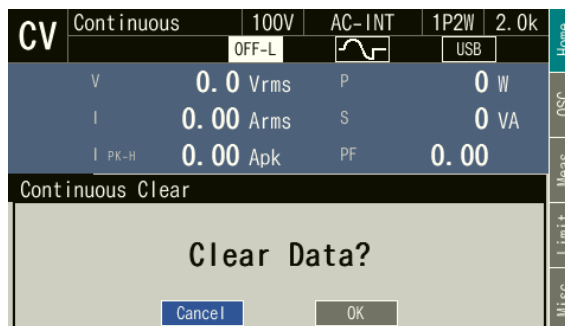

4.7.4 Sequence Memory

The user-created sequence can be saved into the Sequence Memory.

Both the internal and USB memories can be selected as the Sequence Memory. Creation and saving of a sequence are performed using the sequence menu (see 4.2) or the control software. For the content saved in the Sequence Memory, see *Table 4-8*.

The internal memory has 5 Sequence Memories from No. 1 to No. 5.

Table 4-8 Content Saved in Sequence Memory

Setting Item	Factory default setting
Output range selection	100 V
Output mode selection	AC-INT
Parameters of Sequence Function	Refer to 4.28

■ SEQ Memory

In the Memory View, select [Sequence Memory] to change to Sequence Save View. This allows you to recall, save, clear, and rename the sequence. For the operation method, see 4.2.9 and 4.2.10.

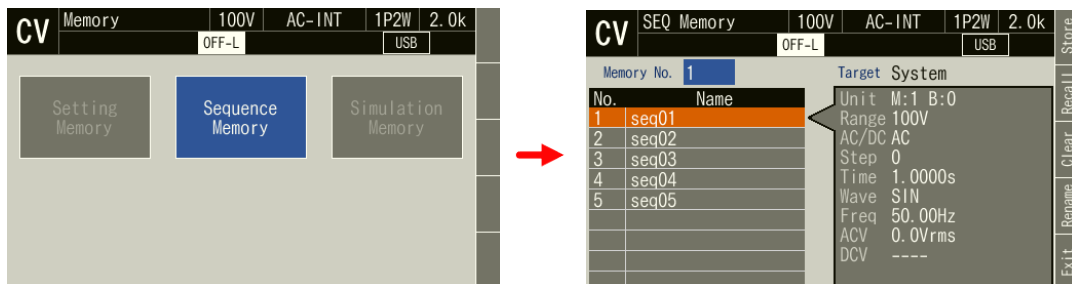

----- Notes -----

- For the Continuous function or Simulation function, first change to the Sequence function and then open the Memory View.

4.7.5 Simulation Memory

The user-created simulation can be saved in the Simulation Memory.

Both the internal and USB memories can be selected as the Simulation Memory. Creation and saving of a simulation are performed using the simulation menu (see 4.3) or the control software. For the content saved in the Simulation Memory, see Table 4-9.

The internal memory has 5 Simulation Memories from No. 1 to No. 5.

Table 4-9 Content Saved in Simulation Memory

Setting Item	Factory default setting
Output range selection	100 V
Simulation Function Parameters	See 4.28

■ SIM Memory

In the Memory View, select [Simulation Memory] to change to the Simulation Save View as below, allowing you to recall, save, clear, and rename the simulation. For the operation method, see 4.3.9 and 4.3.10.

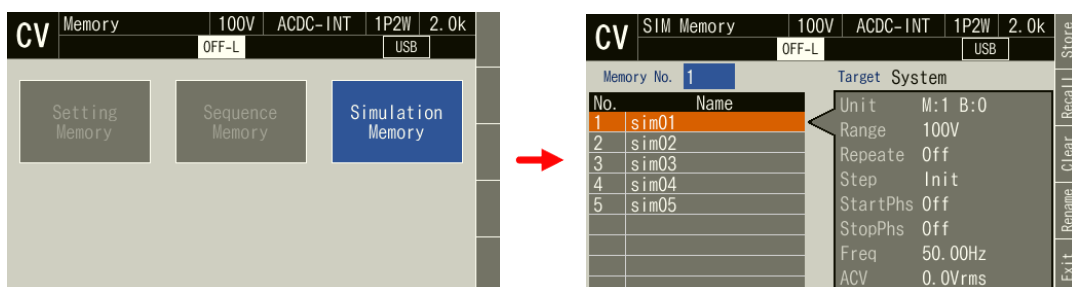

Notes

- For the Continuous function or Sequence function, first change to the Simulation function and then open the Memory View.

4.8 Using USB Memory Function

This product supports the mass storage class USB memory. The sequence data, simulation data, and Basic Setting Memory can be saved into and loaded from the USB memory.

When you connect a USB memory to this product, a window opens with the confirmation message “USB Memory Connected,” then closes after a while.

The root folder of the USB memory should have folders as shown in *Figure 4-23*. Otherwise, these folders are created automatically when the USB memory is connected to this product.

To remove the USB memory connected to this product, the eject operation is necessary as explained in this section.

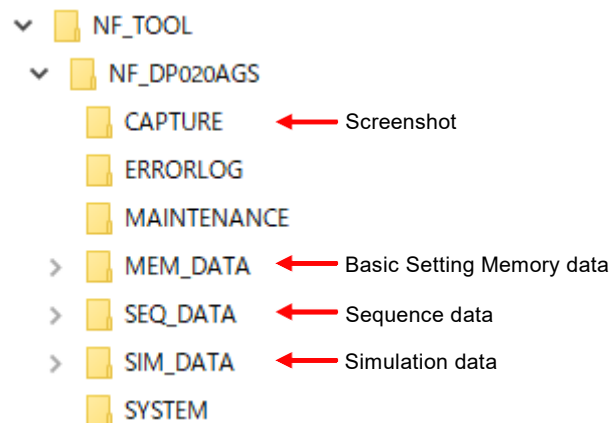

Figure 4-23 USB Memory Folder Structure



⚠ CAUTION

- Do not connect anything other than a USB memory to the front USB memory connector.
- Before removing the USB memory from this product, always perform the eject operation (see the next section). Removing the USB memory while it is being accessed may damage the data.
- Do not turn off this product while it is accessing the data in the USB memory.

----- Notes -----

- We do not guarantee that all USB memories can be operational with this product.
- Use a FAT32-formatted USB memory. This product does not support the exFAT format which began to be supported from Windows Vista SP1.
- This product does not have the USB memory formatting function.
- The file name should consist of one byte alphanumeric characters. A file name that contains any double-byte character cannot be recognized correctly.
- Loading by the external control function is not available.
- Limit the number of files to save in one USB memory up to 500 for each of the basic setting, sequence, and simulation data. If the number of files exceeds this limit, this product cannot recognize the data files in the USB memory.
- The ERRORLOG, MAINTENANCE, and SYSTEM folders in *Figure 4-23* are not used by the users. Do not delete these folders and files in them, as they are used for firmware updating of this product and other purposes.

■ Removing the USB memory from this product (eject operation)

1. Perform the eject operation. Following two methods are available.
 - (a) Shortcut operation:  + 
 - (b) Press the MENU key to move to the root menu, and then select [System]. In the System menu that opens, put the cursor on [Exec] next to the [USB Eject] item, then press the ENTER key.
2. The window opens with the confirmation message “USB Memory Disconnected.” The window closes after a while.
3. Remove the USB memory.



----- Notes -----

- The eject operation cannot be performed in the following cases:
 - When the Memory View is open
 - When the data list box shows the files in the USB memory

4.9 Saving a Screenshot

Save the current screen to USB memory.

■ Operation Method

Press  +  shortcut key.

■ Save destination

The image is saved in the NF_TOOL\NF_DP020AGS\CAPTURE folder. The file format of the saved image is bmp, the number of colors is 65,000, and the size of one file is 256 KiB. The file name is CAP_YYYYMMDD_hhmmss.bmp. YYYYMMDD of the file name is the date, and hhmmss is the time.

4.10 Using Monitor Function

The output voltage and current waveform can be monitored using an oscilloscope connected to the monitor output connector on the rear. For the monitor output specifications, see 10.32.

■ Switching the monitor output

1. Press the MENU key to move to the root menu, and then select [System].

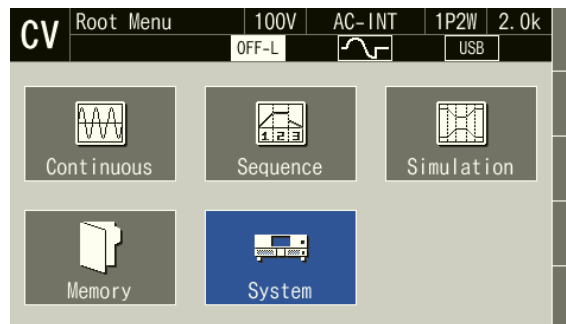

2. Put the cursor on [Setup] of the [Monitor] item, then press the ENTER key.

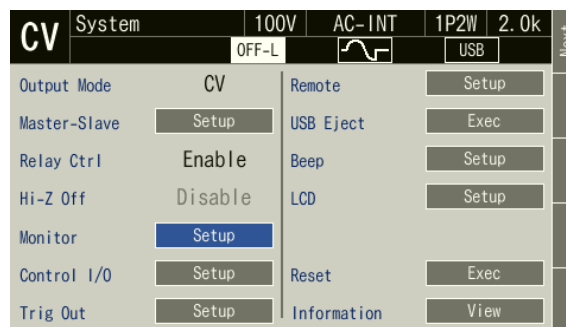

3. The window for selecting the output voltage or current opens. The gain of the signal output from the monitor output connector is displayed on the right side of the window.

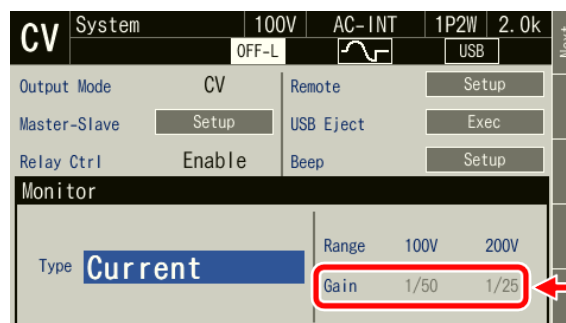

Units:
[V/V] for voltage gain
[V/A] for current gain

(a) When single unit operation

In the [Type] item, select [1:Current] or [3:Voltage].

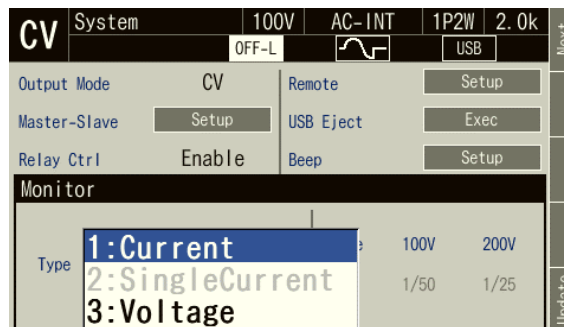

(b) When multi-unit system

In the [Type] item, select [1:Current], [2:SingleCurrent], or [3:Voltage]. For a polyphase system, the monitor output connector of each phase master outputs the monitor signal of that phase.

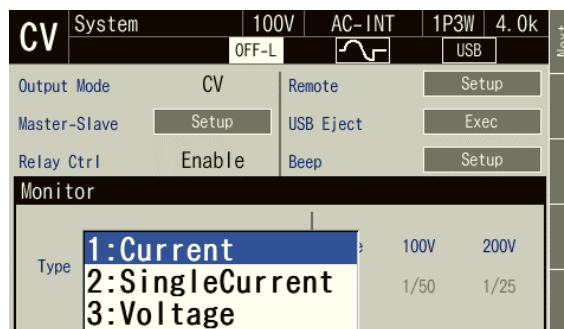

4. Push the [CANCEL] key to close the [Monitor] window.

----- Notes -----

- [When multi-unit system] Selecting [1: Current] outputs the monitor signal of the total output current, and selecting [2: SingleCurrent] outputs the monitor signal for the output current of that single unit.
 - [When multi-unit system] The boosters of a polyphase system (1P3W or 3P4W) and the slaves of a 1P2W system (phase masters and boosters) each outputs the monitor signal of its own single unit, respectively.
 - The output voltage monitor watches the voltage at the output terminal whether the remote sensing state is on or off.
-

4.11 Using Remote Sensing Function

The Remote sensing function detects the output voltage at the voltage sensing terminal. When the Remote sensing function is on, the measured value of the voltage is the voltage at the voltage sensing terminal, and the Sens icon is displayed beside the measurement items. The measured values of power (P, S) and power factor (PF) are also the values that are calculated using the measured voltage value at the voltage sensing terminal.

When the Remote sensing function is on, the output voltage at the voltage sensing terminal is calibrated by the AGC or Autocal function. Thus, by combining the Remote sensing function with the AGC/Autocal function, you can compensate the voltage drop due to wiring to the load.

The Remote sensing function can be turned on only when corresponds to *Table 4-10*. When the Remote sensing function is on, the waveform cannot be changed to other than a sine wave. When the mode is changed to ACDC or when the Sequence or Simulation function is selected, the Remote sensing function is forcibly set to off.

However it can be set to ON in the AC-INT, ACDC-INT and DC-INT modes and when the waveform is a sine wave or DC in case the stand-by state of Sequence mode (step0). In the ACDC mode, Remote sensing cannot be set to ON unless either the AC voltage or DC voltage is 0 V. In addition, when the AC/DC mode is changed, it is turned off first. Turn ON it again when you need.

Notes

- The on/off state of the Remote sensing function is kept even if the output range is changed.
- When the Remote sensing function is forcibly set to off, the settings saved in the System Setting Memory are not updated.

Table 4-10 Modes in Which Can Turn On Remote Sensing, AGC, and Autocal

CV/CC mode	AC/DC mode	Signal source		
		INT	VCA	SYNC
CV	AC *	✓	✓	✓
	DC	✓	✓	

* For AC, they can be set to on only when the waveform is a sine wave.

■ Cable connection for remote sensing

⚠ WARNING

- Before connecting the cable, turn off this product including its peripherals.

⚠ CAUTION

- Pay attention to the withstand voltage of the cable to be connected.
- Do not connect anything to the terminals that are not used.
- Do not input a signal having a different electric potential from the output terminal (for example, the signal at the secondary side of transformer) into the voltage sensing terminal.

Connect the voltage sensing terminal to the output voltage detecting end (for example, load end) using a cable. (See 2.5.) When not using the Remote sensing function, do not connect anything.

■ Turning on/off Remote sensing function

1. Press the [Meas] or [Misc] soft-key and turn on or off the function in the [Rmt Sense] item.

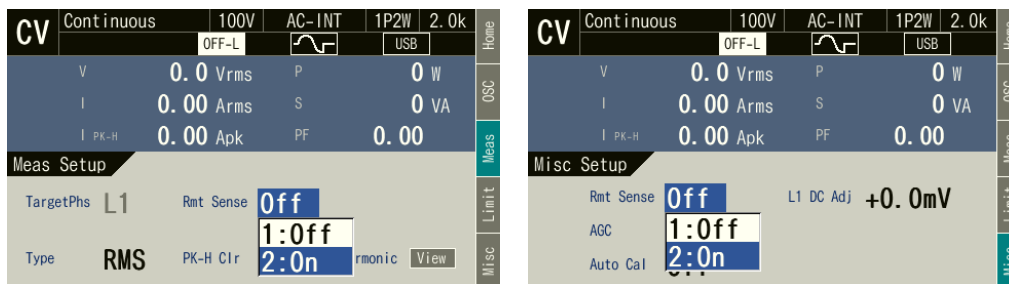

2. When the Remote sensing function is turned on, [Sens] is displayed beside the measurement items.

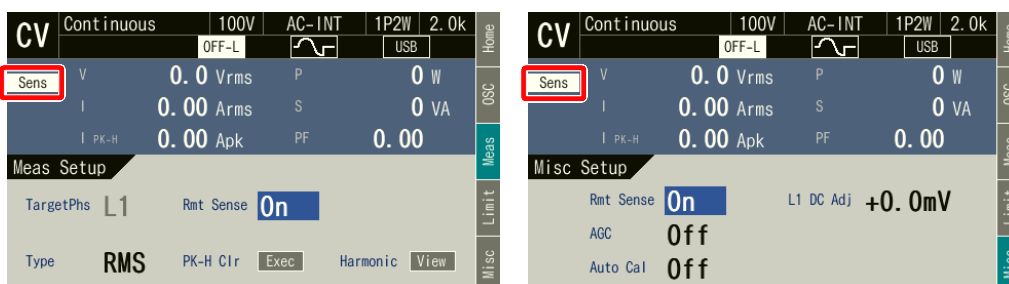

4.12 Using AGC Function



The AGC (Automatic Gain Control) function calculates the ratio (calibration factor) of the output voltage measured value (effective value) versus the output voltage setting value automatically and continuously while this function is on, and multiplies the gain of the output amplifier by the calculated value, intending to match the output voltage with the setting value. With this function, the output voltage fluctuation can be suppressed even when the load is fluctuated. When the AGC function is set to on, the icon  is displayed.

As the detected part of the output voltage calibrated by the AGC function, either the voltage sensing terminal (the Remote sensing function is on) or the output terminal (the Remote sensing function is off) can be selected. By combining the Remote sensing function with the AGC function, you can compensate the voltage drop due to wiring to the load.

The AGC function can be turned on only when corresponds to *Table 4-10*. When the AGC function is on, the waveform cannot be changed to other than a sine wave. When the mode is changed to ACDC, or when the Sequence or Simulation function is selected, the AGC function is forcibly set to off. When the Autocal function is on, the AGC function cannot be used.

For the specification of the AGC function, see *10.20*.

----- Notes -----

- If the output voltage setting is out of the “Operation range” shown in *10.20*, the calibration is not performed while the AGC function setting remains on and the  icon is still displayed.
- If the difference is out of the “Calibration range” shown in *10.20*, the AGC function is forcibly set to off the icon  does not disappear.
- If the limiter operates while the AGC function is on, the AGC calibration is not performed. When the limiter operation is completed, the AGC calibration restarts. If the protection function is activated, the output is turned off, but the AGC setting remains on.
- The on/off setting of the AGC function is kept even if the output range is changed.
- When the AGC function is forcibly set to off, the settings saved in the System Setting Memory are not updated.
- The AGC function updates the calibration factor continuously while the AGC function is on. In contrast, the Autocal function continues to use the calibration factor obtained when Autocal is turned on until Autocal is turned off. Therefore, in the AGC function, the output voltage is calibrated properly even when the load is fluctuated, but there is the response time to reflect the update of the calibration factor. Meanwhile, in the Autocal function, the output voltage may not be calibrated properly when the load is fluctuated, but once Autocal is turned on, there is no response time needed for calibration.

4. Advanced Operation

■ Turning on the AGC function

1. Turn on the output.
2. Open the AGC/Autocal set window. Following two methods are available.
 - (a) Shortcut operation: **SHIFT** + **5**
 - (b) Push the [Misc] soft-key.

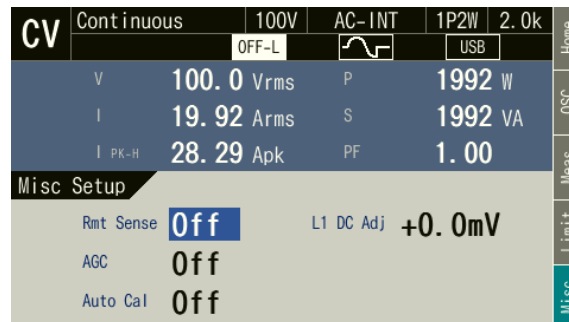

3. Use the [Rmt Sense] item to set the Remote sensing function to on or off, if necessary.

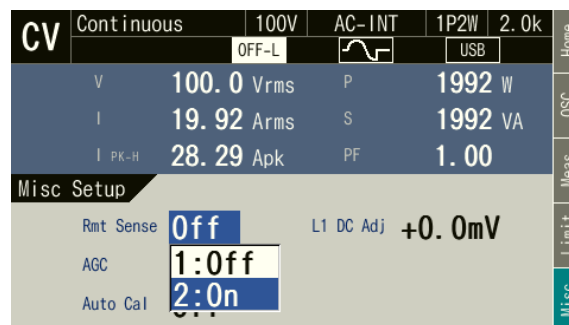

4. In the [AGC] item, select [2:ON]. If the output voltage setting is within the AGC operation range, the AGC calibration is started when [ON] is selected here.

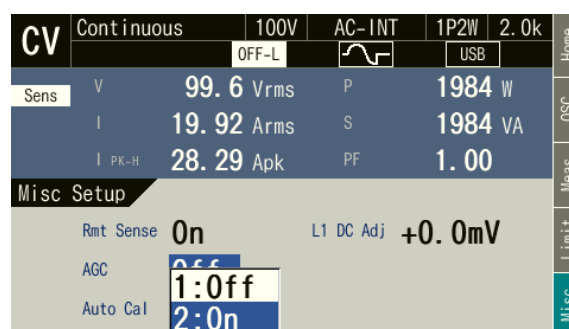

5. Close the window.

■ Turning off the AGC function

1. Open the AGC/Autocal set window. Following two methods are available.

(a) Shortcut operation: **SHIFT** + **5**

(b) Push the [Misc] soft-key.

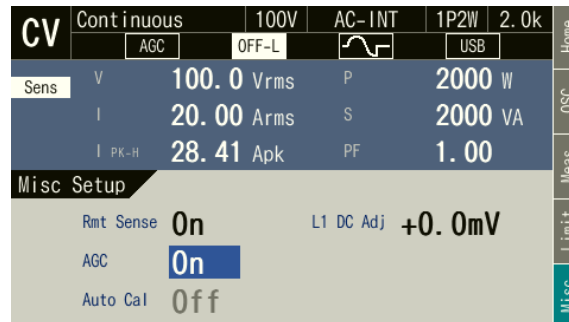

2. In the [AGC] item, select [1:OFF]. When [OFF] is selected here, the AGC calibration finishes.

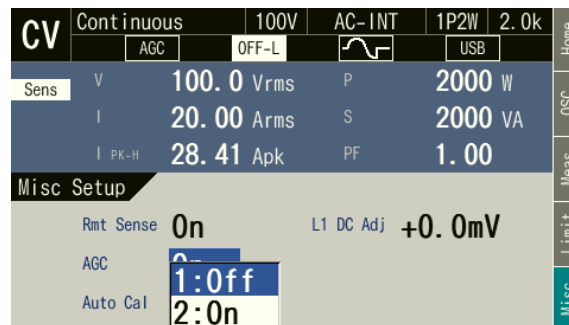

3. Use the [Rmt Sense] item to set the Remote sensing function to on or off, if necessary.

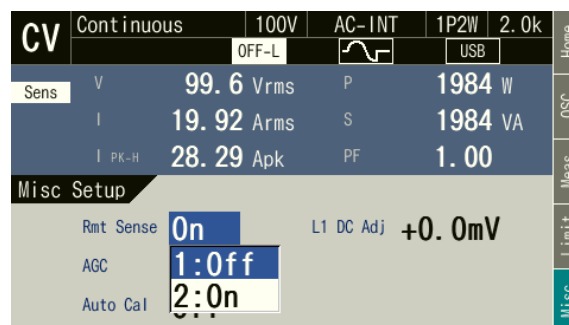

4. Close the window.

4.13 Using Autocal Function

The Autocal (Automatic Calibration) function calculates the ratio (calibration factor) of the output voltage measured value (effective value) versus the output voltage setting value when this function is turned on, and multiplies the gain of the output amplifier by the calculated value, intending to match the output voltage with the setting value. The calculated calibration factor is used as a fixed value until the Autocal function is turned off. Therefore, even when the Autocal function is on, the output voltage fluctuation may occur if the load is fluctuated. When the Autocal function is set to on, the icon  is displayed.

As the detected part of the output voltage calibrated by the Autocal function, either the voltage sensing terminal (the Remote sensing function is on) or the output terminal (the Remote sensing function is off) can be selected. Combining the Remote sensing function with the Autocal function, you can compensate the voltage drop due to wiring to the load.

The Autocal function can be turned on only when corresponds to *Table 4-10*. When the Autocal function is on, the waveform cannot be changed to other than a sine wave. When the mode is changed to ACDC, or when the Sequence or Simulation function is selected, the Autocal function is forcibly set to off. When the AGC function is on, the Autocal function cannot be used.

However it can be set to ON in the AC-INT, ACDC-INT and DC-INT modes and when the waveform is a sine wave or DC in case the stand-by state of Sequence mode (step0). In the ACDC mode, Autocal cannot be set to ON unless either the AC voltage or DC voltage setting is 0 V. In addition, when the AC/DC mode is changed, it is turned off first. Turn ON it again when you need.

For the specification of the Autocal function, see *10.21*.

 Notes

- When the Autocal function is on, the calibration factor is always used to perform the calibration as a multiplier.
 - If the conditions for setting the [Acal] to [On] shown in 10.21 are not satisfied, the Autocal function cannot be turned on. However, if any one of the conditions required for setting [Acal] to [On] becomes disabled while the Autocal function is on, the ON setting of the Autocal function is retained.
 - If the difference is out of the “Calibration range” shown in 10.21, the Autocal function is forcibly set to off.
 - If the limiter operates while the Autocal function is on, the Autocal calibration is still applied, but the limit is applied on the output. If the protection function is activated, the output is turned off, but the Autocal setting remains on.
 - When the output range is changed, the Autocal function is forcibly set to off.
 - When the Autocal function is forcibly set to off, the settings saved in the System Setting Memory are not updated.
 - The Autocal function continues to use the calibration factor obtained when Autocal is turned on until Autocal is turned off. In contrast, the AGC function updates the calibration factor continuously while the AGC function is on. Therefore, in the Autocal function, the output voltage may not be calibrated properly when the load is fluctuated, but once Autocal is turned on, there is no response time needed for calibration. Meanwhile, in the AGC function, the output voltage is calibrated properly even when the load is fluctuated, but there is the response time to reflect the update of the calibration factor.
-

■ Turning on the Autocal function

1. Turn on the output.
2. Open the AGC/Autocal set window. Following two methods are available.
 - (a) Shortcut operation: **SHIFT** + **5**
 - (b) Push the [Misc] soft-key.

CV	Continuous	100V	AC-INT	1P2W	2.0k	Home
		OFF-L		USB		OSC
V	100.0	Vrms	P	1992	W	Meas
I	19.92	Arms	S	1992	VA	Limit
I PK-H	28.29	Apk	PF	1.00		Misc
Misc Setup						
Rmt Sense	Off		L1 DC Adj	+0.0mV		
AGC	Off					
Auto Cal	Off					

4. Advanced Operation

- Use the [Rmt Sense] item to set the Remote sensing function to on or off, if necessary.

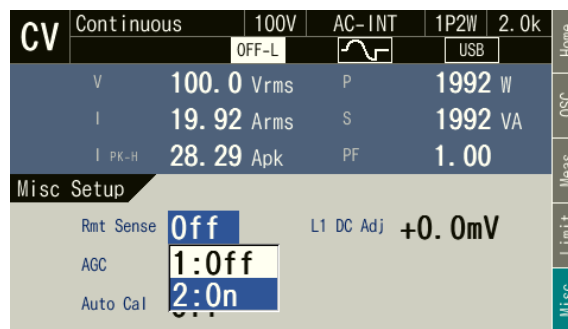

- Use the [Auto Cal] item to turn on or off the Autocal function. When [ON] is selected here, the calibration factor of the Autocal function is calculated, and the calibration is started.

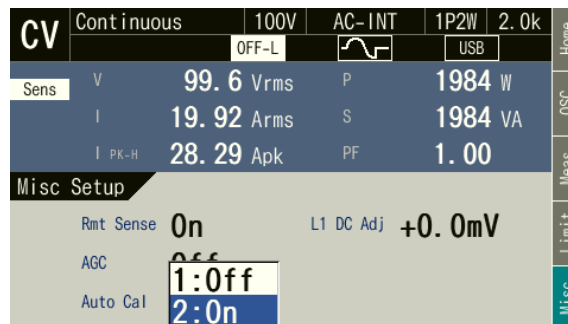

- Close the window.

■ Turning off the Autocal function

- Open the Autocal set window. Following two methods are available.
 - Shortcut operation: **SHIFT** + **5**
 - Push the [Misc] soft-key.

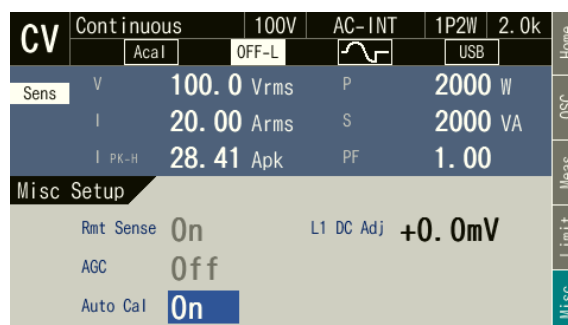

- In the [Auto Cal] item, select [1:OFF]. When [OFF] is selected here, the Autocal calibration finishes, and the calibration factor is cleared.

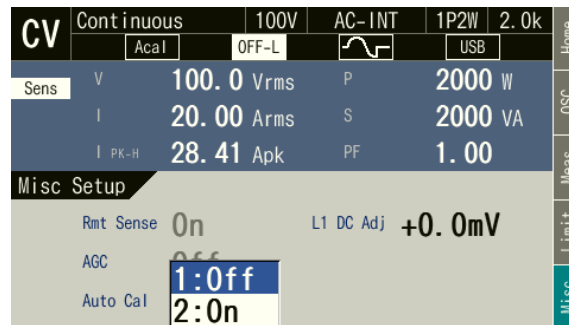

- Use the [Rmt Sense] item to set the Remote sensing function to on or off, if necessary.

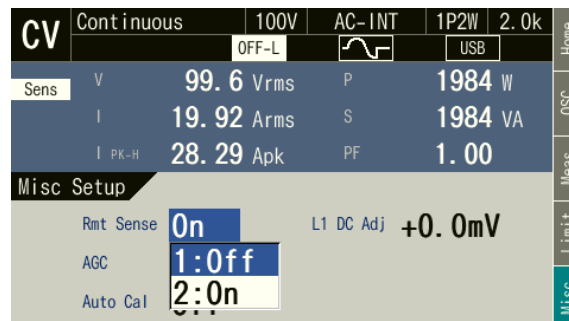

- Close the window.

4.14 Adjusting DC Offset

Even when the output voltage is set to 0 V, a slight DC offset may exist in the output. The DC offset adjustment function can reduce such DC offset close to zero.

For the DC offset adjustment, a total of six types of values are retained for each AC/DC mode in CV mode and for each output range and AC/DC mode in CC mode. For the polyphase system, the values need to be set for each phase. In CC mode, the setting range differs depending on the number of units configuring the multi-unit system. The setting range of the DC offset adjustment value is shown in *Table 4-11* and *Table 4-12*.

Table 4-11 Setting Range of DC Offset Adjustment Value (CV Mode)

Range	AC/DC mode	Minimum value	Maximum value	Resolution	Initial value	Unit
100 V range, 200 V range	AC	-50.0	+50.0	0.1	0.0	mV
	ACDC, DC	-250	+250	1	0	mV

Table 4-12 Setting Range of DC Offset Adjustment Value (CC Mode)

Range	AC/DC mode	Minimum value	Maximum value	Resolution	Initial value	Unit
20 A range	AC	-200×N or -200×(1+B)	+200×N or +200×(1+B)	1	0	mA
	ACDC, DC	-400×N or -400×(1+B)	+400×N or +400×(1+B)	1	0	mA
10 A range	AC	-100×N or -100×(1+B)	+100×N or +100×(1+B)	1	0	mA
	ACDC, DC	-200×N or -200×(1+B)	+200×N or +200×(1+B)	1	0	mA

Note: N is the number of units connected in the system when 1P2W configuration, and B the number of boosters per phase when polyphase system configuration.

■ Operation procedure

1. Push the [Misc] soft-key.

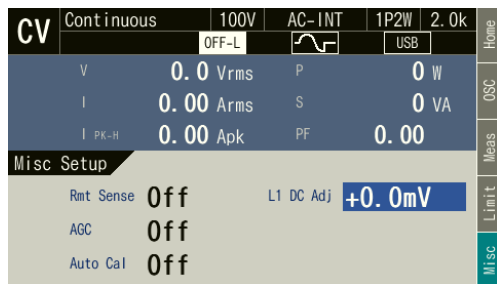

Single unit or single phase system

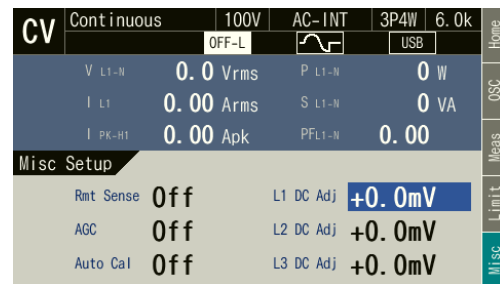

Polyphase system

2. While checking the DC offset of the output voltage, adjust the value in the [DC Adj] item so that the DC offset gets close to zero. For a polyphase system, set the adjustment value of each phase.

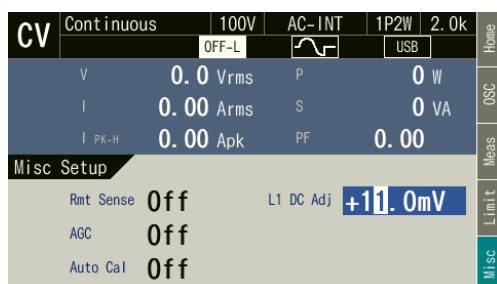

Single unit or single phase system

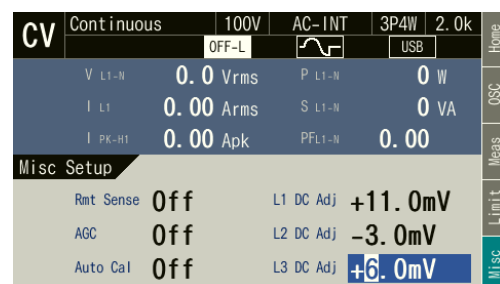

Polyphase system

3. Close the window.

4.15 Using for Unbalanced Polyphase Output

For the polyphase system, you can set the phase voltage and the phase to be unbalanced. The phase can be set to be unbalanced from 0.0 to 359.9 degrees for both L2 phase and L3 phase.

■ Operation procedure

1. Press the [Osc] soft-key and select [2: UNBAL] in the [PhsMode] item.

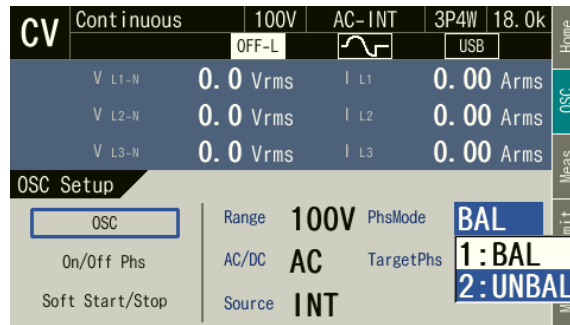

2. Press the [Home] soft-key to return to the Home screen, where you can set the phase voltage or phase current of each phase and the phases.

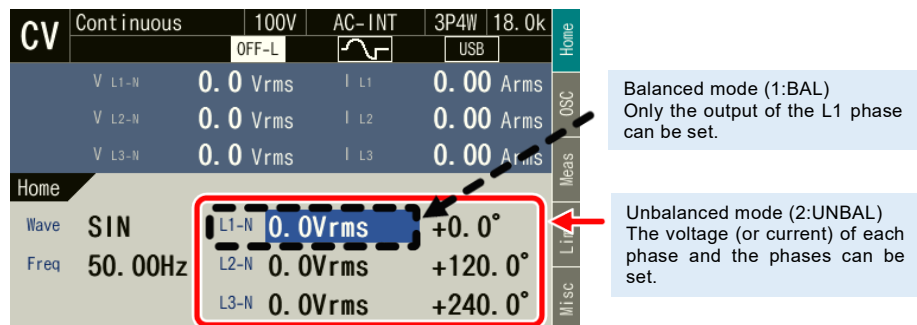

----- Notes -----

- When the unbalanced mode is switched to the balanced mode, the AC voltage of each phase becomes equal to the setting value of the L1 phase. The phase setting value is the value of the balanced mode (180 degrees for 1P3W output, and 120 degrees and 240 degrees for three-phase output).
- Switching between the unbalanced mode and balanced mode is possible even in the output on state.
- Depending on combined condition of the phase angle setting and load, an error message (ID: 53 Power Unit DCPS Overvoltage) may be displayed and the output may be turned off.
- For details on output in balanced mode, see 3.6.5 or 3.6.7.

4.16 Using as DC Power Supply

You can use this product as a DC power supply by switching from the AC/DC mode to the DC mode or the ACDC. For the output setting range, see 10.7.2, 10.8.2.

----- Notes -----

- A 3P4W system cannot be used as a DC power supply. The DC cannot be used. The DC voltage (DCV) of the ACDC also cannot be set.
- The signal sources that can be combined with the ACDC are INT and SYNC.
- The signal sources that can be combined with the DC are INT and VCA.

■ Operation Method

1. Moves to ACDC or DC. Following two methods are available.

(a) Shortcut operation: **SHIFT** + **7**

Every time you press the keys, the mode is switched to AC, ACDC, and DC in this order.

(b) Press the [Osc] soft-key and select [2: ACDC] or [3: DC] in the [AC/DC] item.

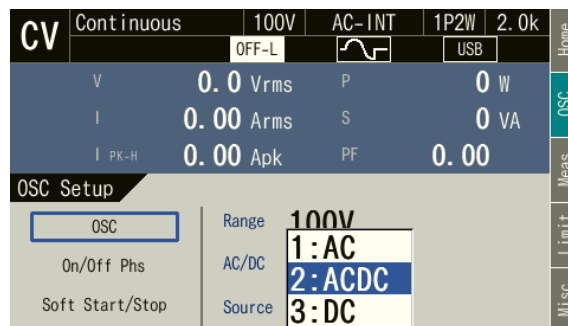

2. Set the output DC voltage in the [DCV] item. In CC mode, set the output DC current in [DCI].

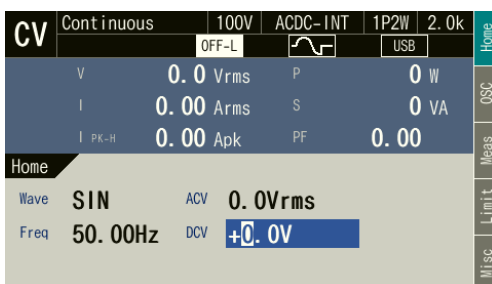

CV mode, ACDC

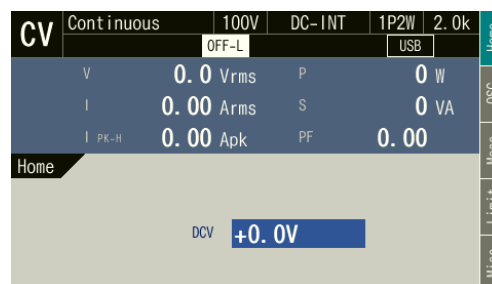

CV mode, DC

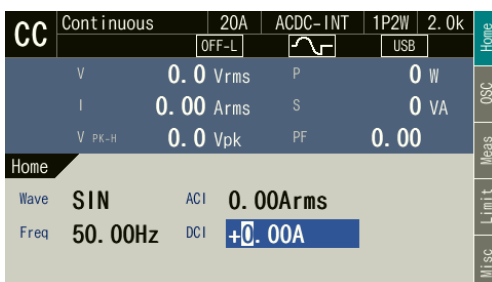

CC mode, ACDC

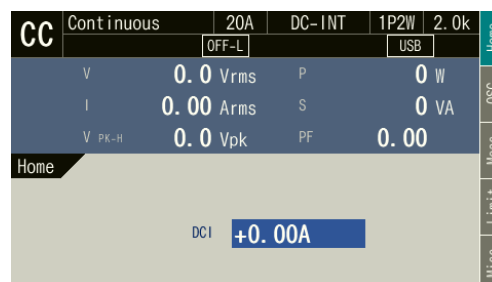

CC mode, DC

4.17 Setting Voltage or Current using External DC Input Signal

In AC-VCA, you can use the external DC input signal to set the AC output voltage or AC output current of the internal signal source. In the DC-VCA, you can use the external DC input signal to set the DC output voltage of the internal signal source. The external DC signal is input to this product through the external signal input connector. When the signal source is VCA, the specifications except the output voltage setting are same as when the signal source is INT.

4.17.1 Using External Signal in AC-VCA

You can set the output AC voltage (ACV) and output AC current (ACC). The peak values of the output AC voltage (ACV) and output AC current (ACC) are set according to the following formulas by using the gain setting value and the voltage of the external DC signal.

$$\text{ACV (Vpk)} = \text{Gain} \times \text{External DC signal voltage (V)}$$

$$\text{ACC (Apk)} = \text{Gain} \times \text{External DC signal voltage (V)}$$

For the specifications of the gain setting range and the external DC signal input voltage range, see 10.25.1.

----- Notes -----

- The gain setting value is retained for each of the output ranges, each of the AC/DC modes, each of the CV/CC modes, and each of the output phase configurations.
- Within the same range and the same mode, the same value is retained for the gain setting value.
- With a polyphase system, the ACV setting using VCA is common to all phases.

■ Examples

1. When the mode is CV, the waveform is SIN, the gain is 100, and the external DC signal voltage is 1 V, the output will be a sine wave of which the amplitude is 100 Vpk (= 70.7 Vrms).
2. When the mode is CV, the waveform is SIN, the gain is 100, and the external DC signal voltage is 1.41 V, the output will be a sine wave of which the amplitude is 141 Vpk (= 100 Vrms).
3. When the mode is CC, the waveform is SIN, the gain is 20, and the external DC signal voltage is 1 V, the output will be a sine wave of which the amplitude is 20 Apk (= 14.1 Arms).
4. When the mode is CC, the waveform is SIN, the gain is 20, and the external DC signal voltage is 1.41 V, the output will be a sine wave of which the amplitude is 28.3 Apk (= 20 Arms).

■ Operation procedure

1. Turn off the output, and set the AC/DC mode and signal source to the AC-VCA. See 3.6.1.
2. Press the [Home] soft-key to open the Home screen. Set the [Wave], [Freq] and [Gain] items.

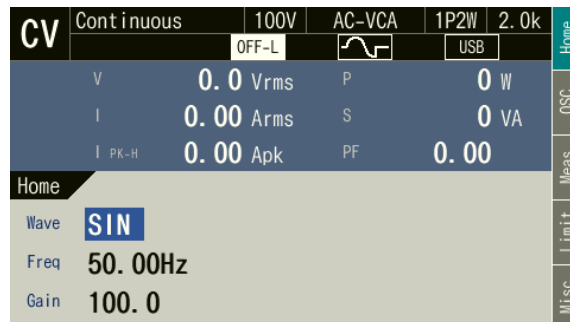

3. Supply a DC voltage to the external signal input connector.
4. Turn on the output.

4.17.2 Using External Signal in DC-VCA

In the DC-VCA, the setting value of the output DC voltage (DCV) or output DC current (DCC) is set according to the following formula, by using the gain setting value and the voltage of the external DC signal.

$$\text{DCV (V)} = \text{Gain} \times \text{External DC signal voltage (V)}$$

$$\text{DCC (A)} = \text{Gain} \times \text{External DC signal voltage (V)}$$

For the specifications of the gain setting range and the external DC signal input voltage range, see 10.25.1.

----- Notes -----

- The gain setting value is retained for each of the output ranges, each of the AC/DC modes, each of the CV/CC modes, and each of the output phase configurations.
 - Within the same range, the same value is retained for the gain setting value.
-

■ Examples

When the mode is CV, the gain is 100, and the external DC signal voltage is 1 V, a DC voltage of 100 V will be output.

When the mode is CC, the gain is 10, and the external DC signal voltage is 1 V, a DC current of 10 A will be output.

■ Operation procedure

1. Turn off the output, and set the AC/DC mode and signal source to DC-VCA. See 3.6.1.
2. Set the [Gain] item.

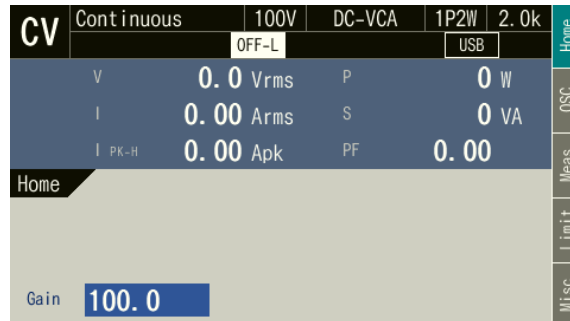

3. Supply a DC voltage to the external signal input connector.
4. Turn on the output.

4.18 Control Using External Control Function

The following functions can be selected.

Item	Description
Disabled	Disable the control input of the CONTROL I/O. The status output signal is output.
Active	Enable the CONTROL I/O.

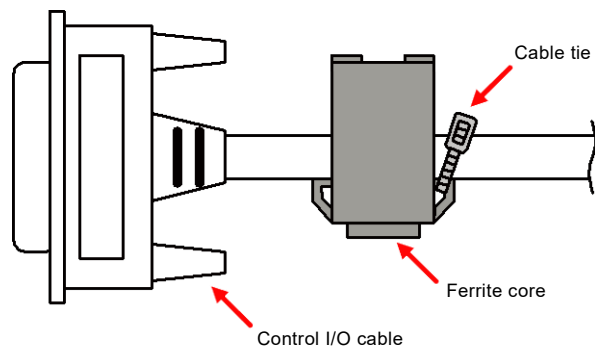

You can control the output on/off and the starting/stopping of Sequence by inputting the logic signal or the non voltage contact signal. You can also get the product state by using the logic signal. The polarity of state output can be switched. The connector to be used is DBLC-J25SAF-10L9E (D-sub, 25-pin, M2.6 mm screw) manufactured by JAE. For the specification of I/O signals, see [10.29](#), and for the pin assignment of the CONTROL I/O connector, see [Table 4-13](#). Attach the provided ferrite core to the product side of the cable connected to the connector. If the cable is thin, bind the cable and ferrite core with the provided cable tie.



Notes

- We recommend that when the external control function is not used, the function is set to [1:Disable] to avoid malfunctioning due to any exogenous noise.
- The external control input signal is ignored when the product is remote controlled via the communication interface.
- The memory 1 and 2 inputs are the inputs for specifying the memory number. For No. 1 to No. 4 memory, specify the 2 bit memory number of the Basic Setting Memory in the Continuous function, or of the Sequence Memory in the Sequence function, or of the Simulation Memory in the Simulation function.
- When the memory recall input is changed from high to low, this loads the data of the Basic Setting Memory in the Continuous function, or of the Sequence Memory in the Sequence function, or of the Simulation Memory in the Simulation function which has the number specified by the memory 1 and 2 inputs. For the Sequence and Simulation function, the compile is also performed.

Table 4-13 CONTROL I/O Pin Assignment

pin	I/O	Function	Remarks
1	Output	Power On/Off	Low: Off, High: On
2	Output	Output On/Off*	Low: On, High: Off (Negative) Low: Off, High: On (Positive)
3	Output	Protection operation*	Low: Active, High: None (Negative) Low: None, High: Active (Positive)
4	Output	Limiter operation*	Low: Active, High: None (Negative) Low: None, High: Active (Positive)
5	Output	AGC/Autocal setting state*	Low: On, High: Off (Negative) Low: Off, High: On (Positive)
6	Output	Software busy*	Low: Busy, High: Ready (Negative) Low: Ready, High: Busy (Positive)
7	Output	Output range	Low: 200 V, High: 100 V (CV mode) Low: 10 A, High: 20 A (CC mode)
8	Output	Output phase configuration	Low: 1P2W High: 1P3W or 3P4W
9	Output	Step sync code 1 (bit 0)	High level or Low level (See <i>Table 4-14</i>)
10	Output	Step sync code 2 (bit 1)	
11	Output	Trigger	Positive  or Negative 
12	Output	Output mode CV/CC	Low: CV, High: CC
13	Input	Output off	Falling Off
14	Input	Output on	Falling On
15	Input	Sequence start/resume	Falling Start
16	Input	Stop of sequence	Falling Stop
17	Input	Sequence is in the Hold status	Falling Hold
18	Input	Sequence branch 1	Falling Branch start
19	Input	Sequence branch 2	Falling Branch start
20	Input	Memory recall (+ compile)	Falling Recall
21	Input	Memory specification 1	Specify 0 to 3 (See <i>Table 4-15</i> , equivalent to memory 1 to 4, respectively)
22	Input	Memory specification 2	
23	Input	Clear the current peak-hold value	Falling Clear
24	–	GND	–
25	Reserved	Do not connect anything.	Do not connect anything.

Note 1: The polarity of state output marked with asterisk (*) can be switched.

Note 2: At 25th pin, +5 V is output for test in manufacturing, and the pin is not assumed to be used by user. Do not connect this pin to anything, or the product might become unstable.

Table 4-14 Step Sync Code

bit	Step sync code			
	LL	LH	HL	HH
0	Low	High	Low	High
1	Low	Low	High	High

Table 4-15 Memory Specification

	Memory No.			
	1	2	3	4
Specify	0	1	2	3
Memory specification 1	Low	High	Low	High
Memory specification 2	Low	Low	High	High

■ Enabling/disabling external control function

1. Press the MENU key to move to the root menu, and then select [System]. The system setting window opens.

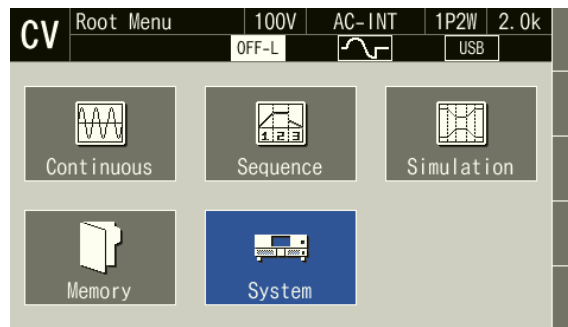

2. Select the [Control I/O] item to open the setting window.

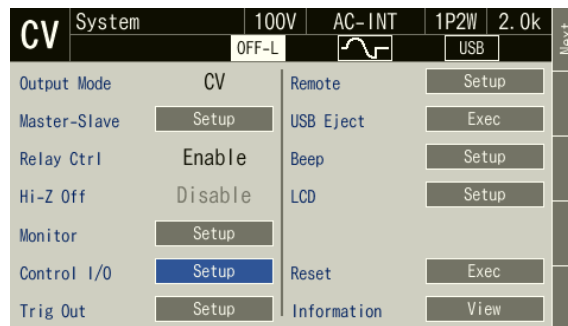

3. In the [Ext Ctrl] item, select [1:Disable] or [2:Enable].

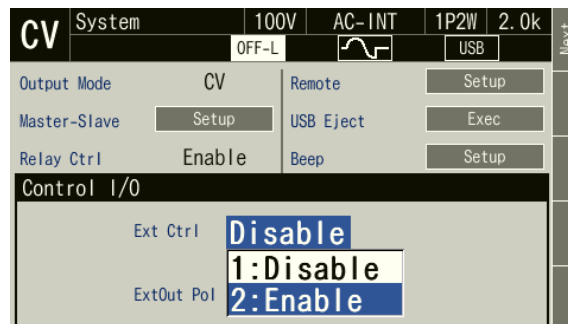

■ Setting the polarity of the state output

Open the setting window of Control I/O, and select [Negative] or [Positive] in the [ExtOut Pol] item.

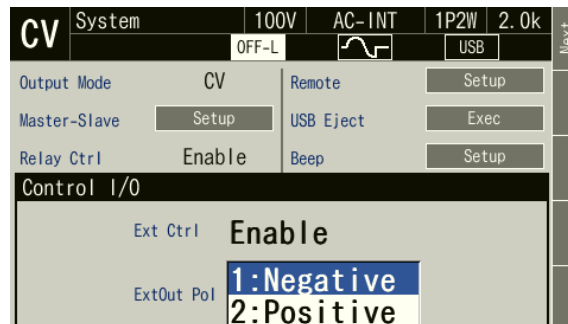

■ Setting the trigger output

1. Press the MENU key to move to the root menu, and then select [System]. The system setting window opens.

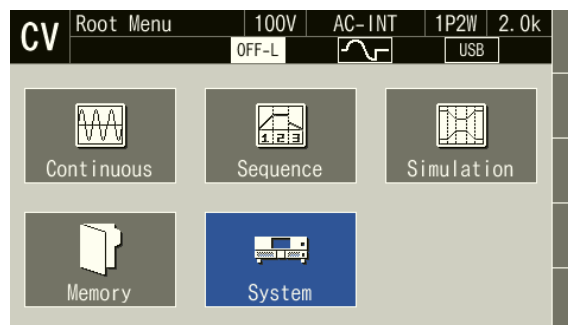

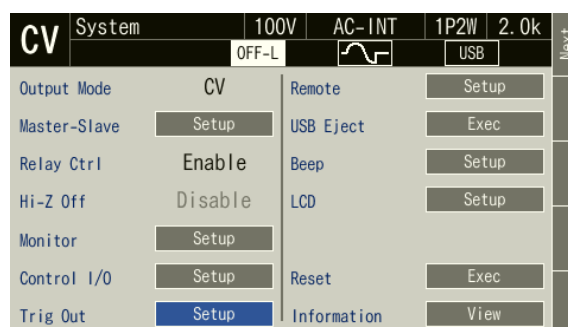

2. Select the [Trig Out] item to open the trigger output setting window.

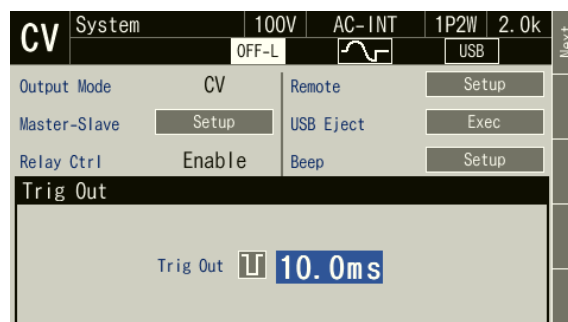

3. Set the pulse width.



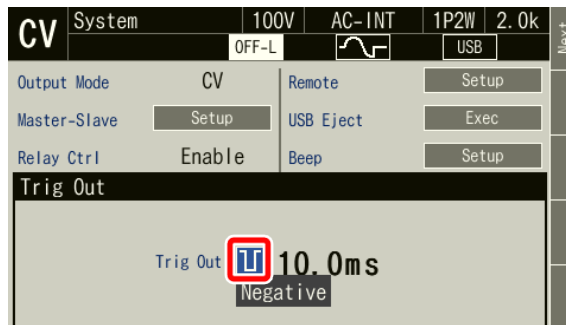

4. Move the cursor to the icon on the left side of the pulse width setting value to display the polarity of the trigger output (Negative  / Positive ). If you select the icon, you can change the polarity.



5. Press the CANCEL key. The setting window closes.

4.19 Synchronizing the Output Frequency with the Power Line or the External Signal

When you select SYNC for the signal source, you can synchronize the frequency of the internal signal source with the power line or the external signal. The icon  is displayed when the internal signal source is synchronized with the external signal. The icon  is displayed when the synchronization is not performed. See 10.15 for the measurement specification of the synchronization frequency and 10.25.2 for the interface specification of the external synchronization signal.

----- Notes -----

- The output on phase/off phase setting (3.6.9) is valid in SYNC also.
 - You cannot make the output on if synchronization is not performed.
-

■ Operation procedure

1. If you want to synchronize the internal signal source with the external signal, input the synchronization signal by using the external signal input connector. If you want to synchronize it with the power line, this step is not necessary.
2. Press the [Osc] soft-key and select [3:SYNC] from the [Source] item.

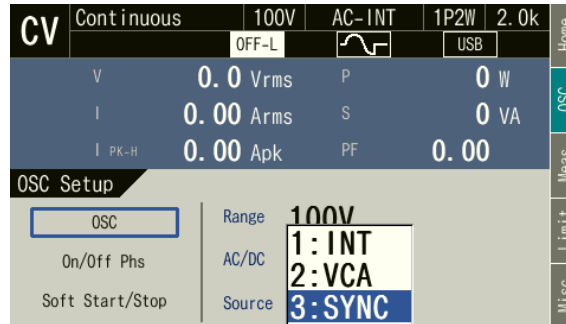

3. Press the [Home] soft-key to open the Home screen. In the [Source] item, select [1:Line] (power input) or [2:Ext] (external input signal) as the synchronization signal source.

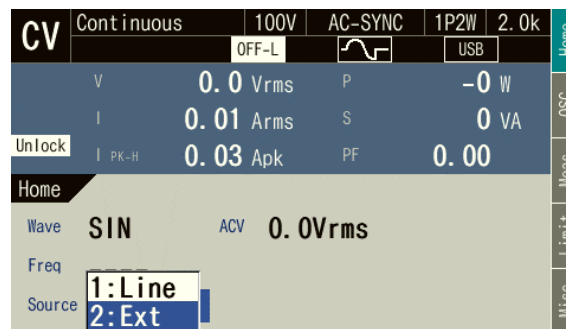

4. When the internal signal source is synchronized, the measured synchronization frequency value is displayed. Also, the icon is displayed.

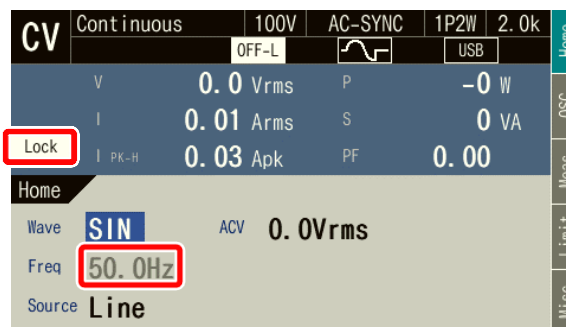

4.20 Turning the Output On or Off Rapidly

In the factory default settings, the internal output relay of this product is activated linking to the output on/off. In the output off state, the internal circuit and output terminal of this product are physically separated. On the other hand, if output relay chattering causes any problem or if you want to turn the output on or off rapidly, you can disable the control of the output relay. In that case, the output relay is fixed to the on state and the operation to turn the output on/off is performed by the semiconductor device. The output off state means the state of high impedance. The output terminal impedance in the output off state when the output relay control is disabled is 50 k Ω for the 100 V range and 20 A range, and 100 k Ω for the 200 V range and 10 A range (reference values of output terminal).

Notes

- Even when the output relay control is disabled, the output relay is turned off if the protection function is activated. While the error message appearing when the protection function is activated displays “Press Enter Key,” pressing the ENTER key clears the message and turns on the output relay again although the output remains off.
- The output relay is in the off state during the wait time at power-on even if the output relay control is disabled.
- In CC mode, the output relay control is disabled (fixed to the on state). For the combination of the CV/CC mode, high impedance output off, and output relay control that can be set, see *Table 4-16*.
- If the output relay control is disabled, the display of the icon  is inverted so that it has a black background.

■ Operation procedure

1. Press the MENU key to move to the root menu, and then select [System]. The system setting window opens.

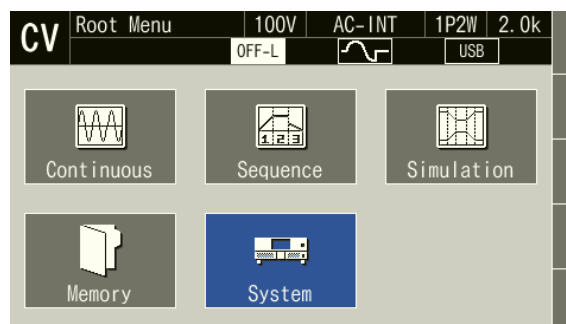

- In the [Relay Cntrl] item, select [1:Disable] or [2:Enable]. If you select [2:Enable], the activation of the output relay is enabled. If you select [1:Disable], the output relay is fixed to the on state and the operation to turn the output on/off is performed by the semiconductor device rapidly.

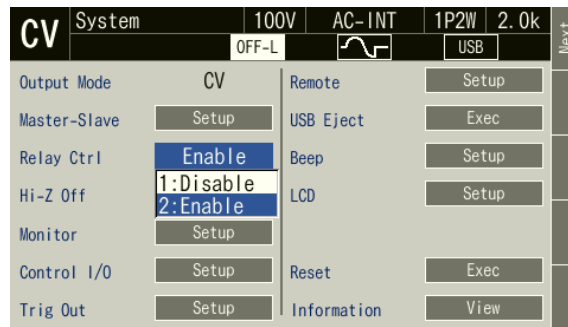

4.21 Turning Output Off in the High Impedance State

When the high impedance output off function is enabled, the output is off in the high impedance state. This enables turning off the output without discharging the electrical charge of a capacitor or battery connected to the output.

When the high impedance output off function is disabled, the output is turned off after the output voltage is set to 0 V. This enables controlling the voltage surge when the output is off.

In CC mode, this is disabled. For the combination of the CV/CC mode, high impedance output off, and output relay control that can be set, see *Table 4-16*.

Table 4-16 CV/CC Mode, High Impedance Output Off, and Output Relay Control

High impedance output off	CV/CC mode	Output relay control	
		Enabled (On/off operation)	Disabled (Fixed to on)
Enabled	CV mode	No	Yes
Disabled (Output off after 0 V)		Yes	Yes
	CC mode	No	Yes

■ Operation procedure

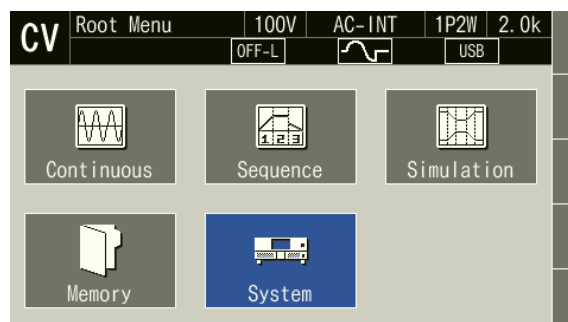

- Press the MENU key to move to the root menu, and then select [System]. The system setting window opens.

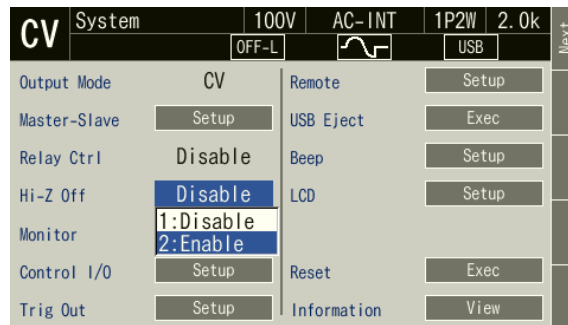

- In the [Hi-Z Off] item, select [1:Disable] or [2:Enable]. If you select [2:Enable], the high impedance output off function is enabled. If you select [1:Disable], it is disabled.



----- Notes -----

- When the high impedance output off function is enabled, the icon changes from  to .

4.22 Enabling Automatic Output-On at Power-On

You can set the automatic output-on after power-on. If you set the output-on at power-on setting to [ON], the message window as shown in *Figure 4-24* is displayed for about 10 seconds after you turn on the power and the self check at start-up, until the output becomes on automatically. If you press the ENTER key in the control panel or CANCEL key during this process, the output-on at power-on setting is set to off and the output is not enabled automatically. If you do not perform this key operation, the output on is enabled automatically after the message window is closed.

----- Notes -----

- The output-on at power-on setting is valid only in the Continuous function. If you set so that the Sequence or the Simulation function is selected at power-on (see 4.2.11 and 4.3.11), the output is not turned on automatically when turning on the power even if the output-on at power-on setting is set to on.
- If the unit is in the Remote state immediately after the start-up, the output-on at power-on setting is set to off and the output is not turned on automatically. The message window shown in *Figure 4-24* is not displayed.
- If the unit enters the Remote state while the message window shown in *Figure 4-24* is displayed, this message window closes and the output-on at power-on setting is set to off, therefore the output is not turned on automatically.

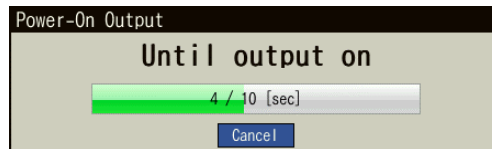
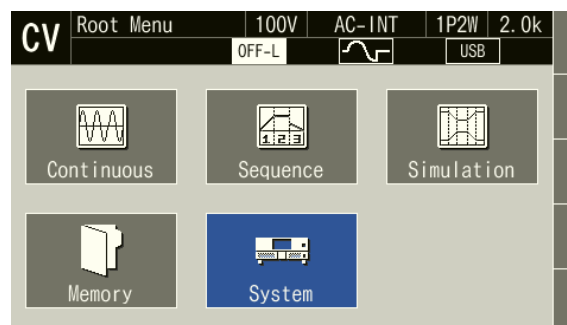

Figure 4-24 The Message Window to be Shown Before the Automatic Output-On After the Power-On

■ Operation procedure

1. Press the MENU key to move to the root menu, and then select [System]. The system setting window opens.



2. In the [PwON Output] item on page 2 of the system setting window, select [1: ON] or [2: OFF]. When you select [On], the automatic output-on at power-on is enabled.

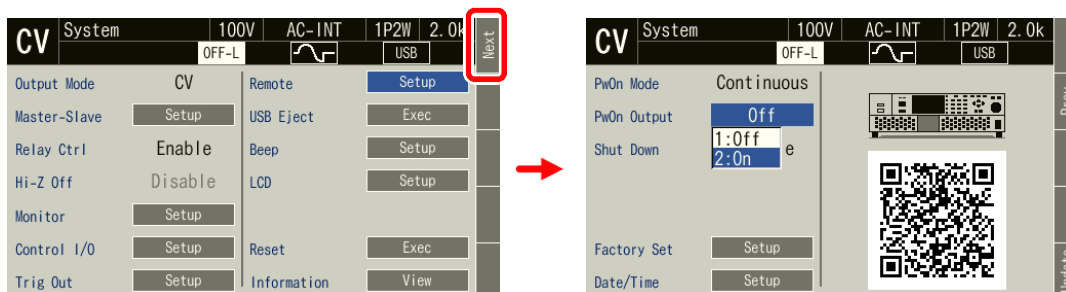

4.23 Key Lock

If the key lock is enabled, operations using the keys or MODIFY dial are not accepted. The acceptable operations are for enabling the output off and the key lock only. This function helps to avoid the incorrect user operations during running. The icon  is displayed when the key lock is enabled.

■ Operation procedure

The Shortcut operation  +  toggles between on/off of the key lock.

4.24 Beep

You can set whether or not a beep sounds when performing key operations or limiter operations. If the protection function is activated, the unit beeps regardless of the settings.

■ Operation procedure

1. Press the MENU key to move to the root menu, and then select [System]. The system setting window opens.

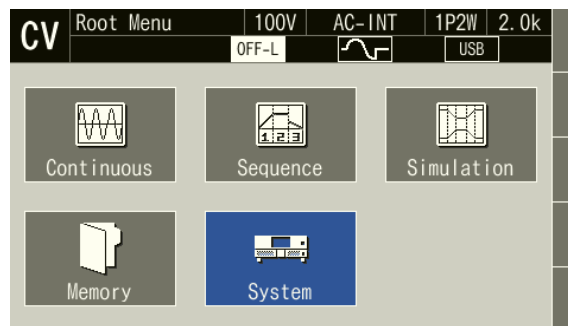

2. Select the [Beep] item to open the setting window.

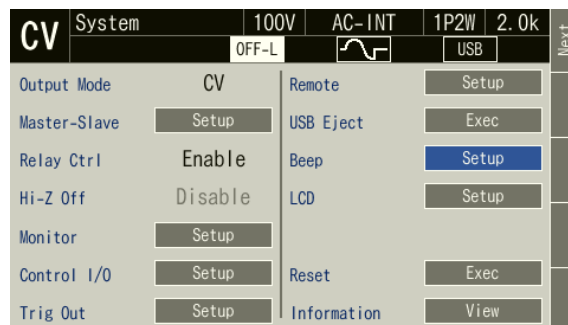

3. Set to On/Off the beep sound for limiter operations in the [Limiter] item, and the beep sound for key operations in the [Key] item.

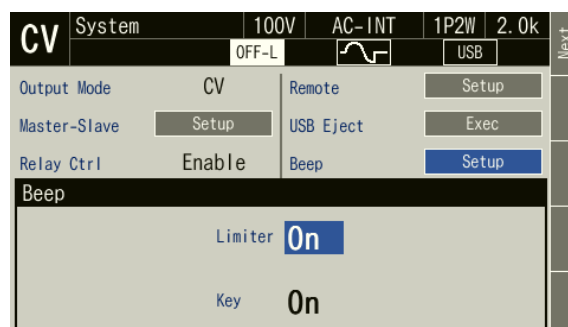

4.25 Changing the Screen Brightness

You can change the brightness of the LCD screen backlight. The brightness can be adjusted to any of 100 levels from 0 to 99. For the setting specifications, see 10.26.

■ Operation procedure (master)

1. Open the window for adjusting the LCD. Following two methods are available.
 - (a) Shortcut operation: **SHIFT** + **9**
 - (b) Press the MENU key to move to the root menu, and then select [System]. The system setting window opens. Put the cursor on [Setup] next to the [LCD] item, then press the ENTER key.

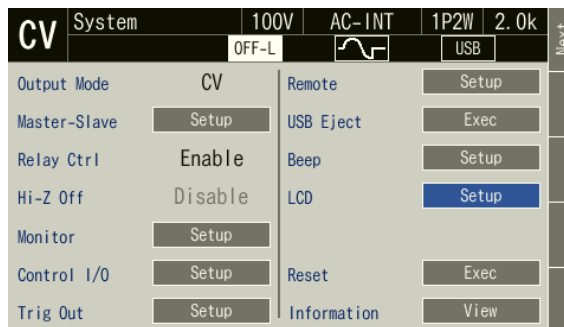

2. Adjust the brightness in the [Brightness] item. The larger the value, the brighter the screen.

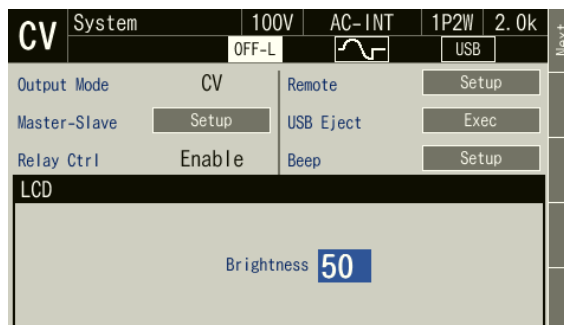

3. Push the [CANCEL] key to close the window.

----- Notes -----

- In a multi-unit system, you can set the brightness for each unit individually.

■ Operation procedure (slave)

1. Press the [LCD] soft-key to open the window for adjusting the LCD.



2. Adjust the brightness in the [Brightness] item in the same way as for a master.

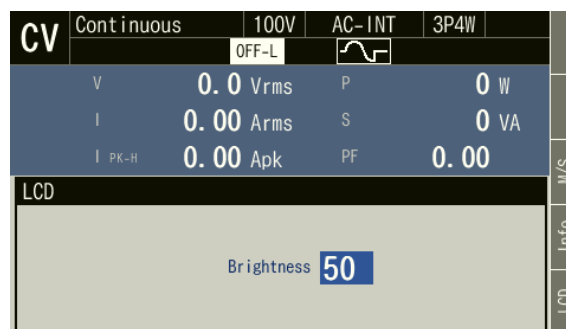

4.26 Using the Shutdown Function

This function forcibly turns off the output to stop operation by using an external signal (or non-voltage contact). Enable and disable can be selected by configuring a setting. An operation stop is performed when the input is high, and normal operation is performed when it is low. To recover after a shutdown, cycle the power.

Notes

- In the multi-unit system, phase master and booster are linked to the system master. The input terminals of the phase master or the booster are disabled.

■ Connection method

Connect the terminals of the provided SHUT DOWN connector so that it is short-circuited during normal operation and open during shutdown, and then insert it into the SHUT DOWN connector of the unit. For the specifications of the non-voltage contact, see 10.3.

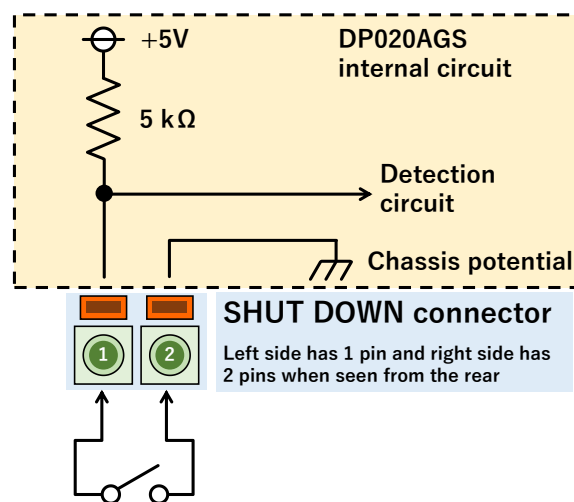
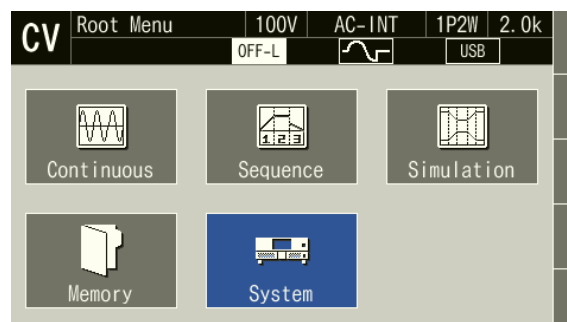

Figure 4-25 Example of Connecting SHUT DOWN Connector

■ Operation procedure (setting the shutdown function)

1. Press the MENU key to move to the root menu, and then select [System]. The system setting window opens.



4. Advanced Operation

- In the [Shut Down] item on page 2 of the system setting window, select [1: Disable] or [2: Enable].

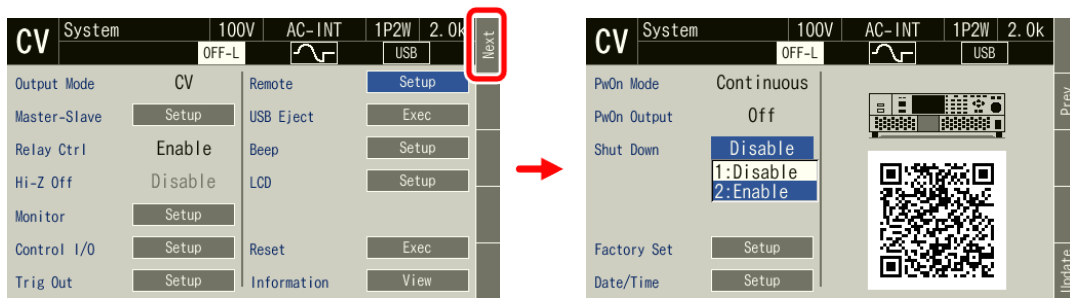

■ Operation procedure (recovering from shutdown)

The following two methods are available for recovery after shutdown.

- Restart the power when state of connected between the terminals of the SHUT DOWN connector.
- Disable the shutdown function to restart the power supply.

Press the [Sht Dn] soft-key to open the shutdown function setting window. Change the [Shutdown] item to [Disable].

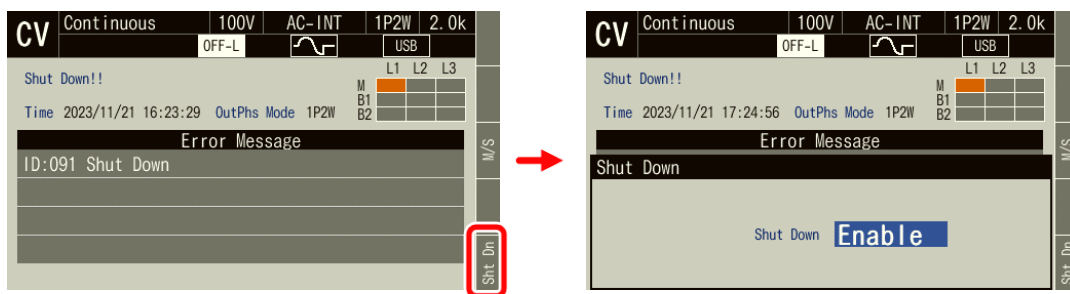

4.27 Setting the Date and Time

The date and time are used for the creation date and time of files saved by the memory function. The setting range is as follows.

00:00:00 on January 1, 2022, to 23:59:59 on December 31, 2099

■ Operation procedure

- Press the MENU key to move to the root menu, and then select [System]. The system setting window opens.

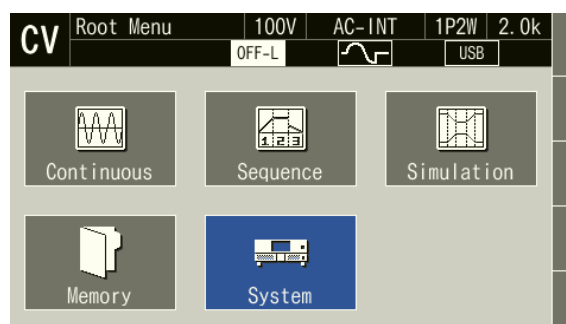

- Select the [Date/Time] item on page 2 of the system setting window. The date and time setting window opens.

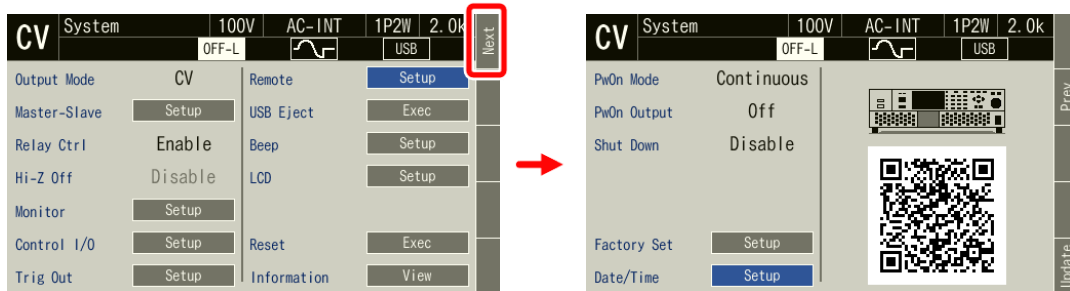

- Enter the date and time, and then finally select [OK].

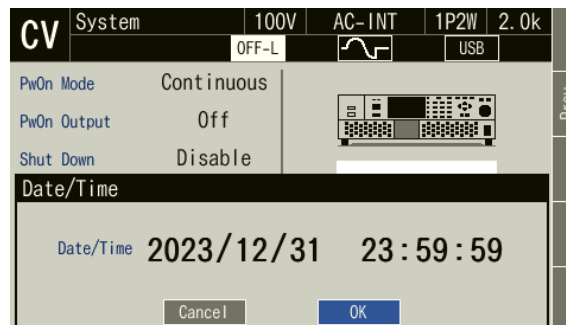

Notes

- This product has a built-in battery. As the battery depletes, the time will deviate. For replacement of the battery, contact the seller (NF Corporation or our agent) from whom you purchased this product.

4.28 Restoring Initial Settings

4.28.1 Resetting

If you perform a reset, the setting items marked with “○” in *Table 4-17* are restored to the setting values in the table. Ensure that you reset this product in the output off state.

Table 4-17 Setting Items to be Reset

Setting Item	Reset	Setting value
Output on/off	×	Off
Master/Slave	×	Disabled, 10 s
Output phase configuration	×	1P2W
Output range	○	100 V range
CV/CC mode	○	CV mode
AC/DC mode	○	AC
Signal source	○	INT
External synchronization signal (LINE or EXT)	○	LINE
AC voltage setting	○	0 V
Frequency	○	50 Hz
Output waveform	○	Sine wave
Output on phase	○	0.0°
Output off phase	○	Enabled, 0.0°
Soft start	○	Disabled
Soft stop	○	Disabled
Phase voltage/Line voltage setting selection	○	Phase voltage
Line voltage setting	○	0 V
Phase angle setting	○	1P3W: 180° 3P4W: 120°, 240°
Balanced/Unbalanced	○	Balanced
DC voltage setting	○	0 V
Current limiter	○	See 10.16
Voltage limiter	○	See 10.17
Setting range limit	○	See 10.18
External input gain	○	0
Output function	○	Continuous
DC Offset	×	0 mV (CV mode), 0 mA (CC mode)
Measurement display phase *1	○	L1
Measurement unit selection	○	RMS1
Remote sensing	○	Off
AGC	○	Off
Autocal	○	Off
Screen (LCD) brightness	×	50
Beep	○	Key operation sound on, limiter operation sound on
Key lock	○	Off
High impedance output off	○	Disabled
Output relay control	○	Enabled
Output setting at power-on	○	Off

Table 4-17 Setting Items to be Reset (Continued)

Setting Item	Reset	Setting value
Trigger output setting	○	Negative, 10 ms
Time unit	○	s
Monitor output target	○	Current
External interfaces	×	USB
External control function	×	Disabled
SHUT DOWN	×	Disabled
Clipped Sine Wave *2	○	Clip ratio specified Clip ratio: 100 % Crest factor: 1.41
Sequence parameters	○	Output range: 100 V AC/DC mode: AC-INT Step Time: 1 s Intra-Step behavior: Constant Waveform: SIN Frequency: 50 Hz DC voltage: 0 V AC phase voltage: 0 V Start Phase: Disabled, 0° Stop Phase: Disabled, 0° Phase angle: 1P3W 180° Three-phase 120, 240° Step termination: Continue Jump count: 1 Jump-to step specification: OFF Step sync output: LL Branch step specification: OFF Trigger output: Off
Simulation parameters	○	Output range: 100 V Step Time: 0.1 s Frequency: 50 Hz AC voltage: 0 V Start Phase: Disabled, 0° Stop Phase: Disabled, 0° Step sync output: LL Trigger output: Off Repeat count: Disabled 1

*1: The measurement display phase is L1 regardless of the output phase configuration.

*2: All three of the clipped sine waves are initialized.

■ Operation procedure

1. Press the MENU key to move to the root menu, and then select [System]. The system setting window opens.

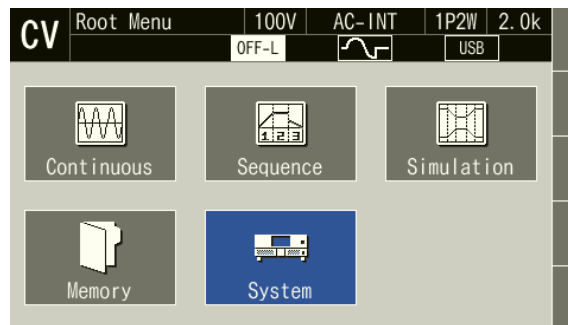

2. Put the cursor on [Exec] next to the [Reset] item, then press the ENTER key. The reset operation is performed.

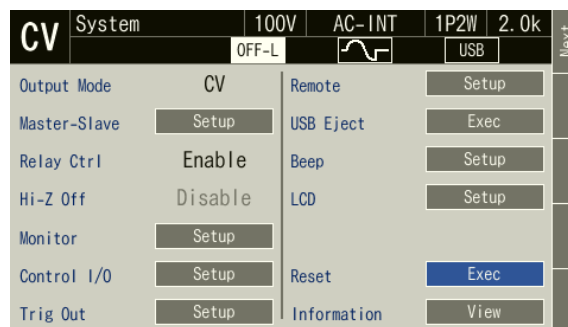

----- Notes -----

- If you reset the product, the content in the Basic Setting Memory will not be cleared. Once restarted, the setting of the Basic Setting Memory No.1 is recalled. To reset the setting after restart to the factory default setting, see 4.7.3 to clear the content of the Basic Setting Memory No.1.
-

4.28.2 Restoring the Factory Default State

If you perform a factory setup, all items in *Table 4-17* are restored to their setting values. In addition, all of the Basic Setting Memory, sequence memory, and simulation memory are returned to their initial settings.

Factory settings should be made with the output switched off during single-unit operation.

■ Operation procedure

1. Press the MENU key to move to the root menu, and then select [System]. The system setting window opens.

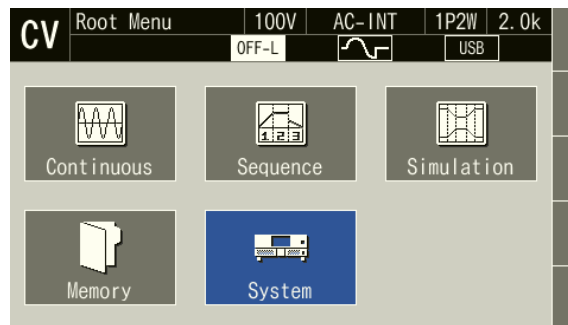

2. Put the cursor on [Exec] of the [Reset] item on page 2 of the system setting window, and then press the ENTER key.

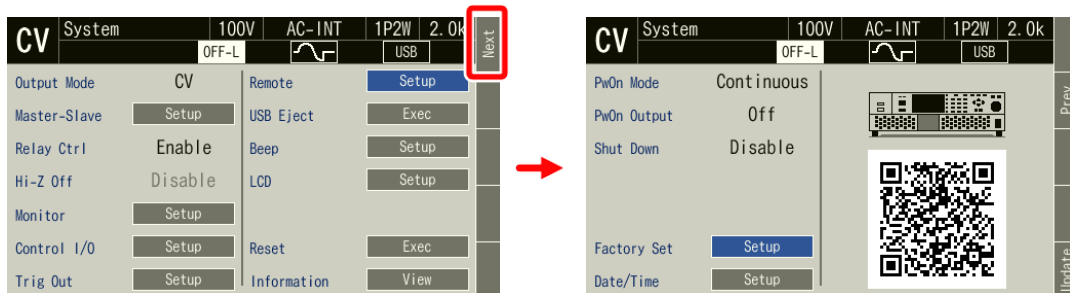

3. The execution dialog box opens. Press the Enter key to start initialization and set the factory default settings.

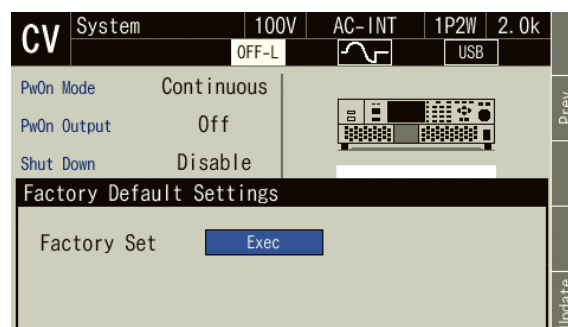

----- Notes -----

- A factory setup is not performed with a multi-unit system. Perform it during single unit operation.

5. Description of Screen and Menu

5.1	Screen Configuration.....	166
5.2	Menu Composition	169

5.1 Screen Configuration

Figure 5-1 shows the basic screen configuration. It consists of display areas marked as “a” to “i”. The description of each area is shown in Table 5-1.

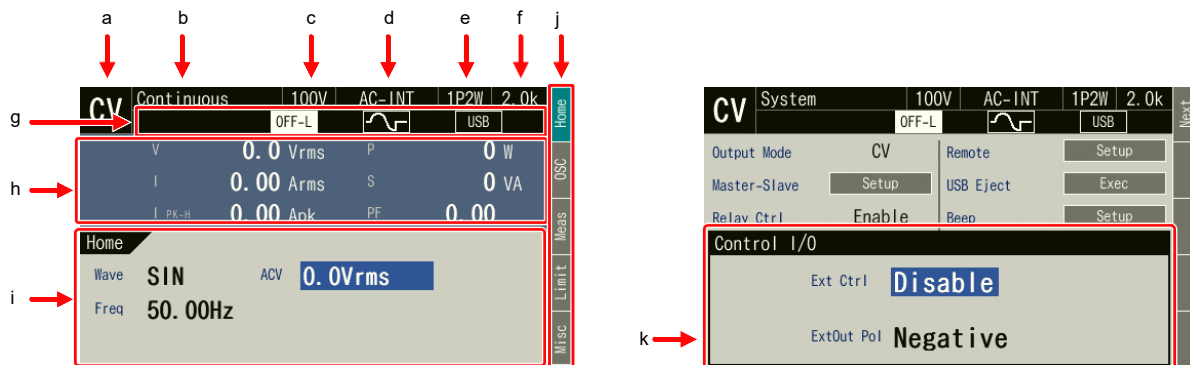

Figure 5-1 Component Name (Display Areas on the Screen)

Table 5-1 Component Name (Display Areas on the Screen)

Symbol	Area name	Description	Refer to
a	Output mode	Current output mode. CV or CC is displayed.	3.7
b	Screen title	Title of the currently displayed screen.	—
c	Output range	Current output range.	3.6.2
d	AC/DC mode and signal source	Displayed in the format of the current “AC/DC mode - Signal source.”	3.6.1
e	Output phase configuration	Current output phase configuration. 1P2W: Single-phase two-wire/ 1P3W: Single-phase three-wire/ 3P4W: Three-phase four-wire	3.5
f	Rated power	Rated output power of the current system.	3.4.2
g	Status icon	The area where an icon is displayed when the product enters the specific state, for example, when the limiter is activated.	5.1.1
h	Measured value area	The measured values are displayed.	3.6.13
i	Output display area	The output setting is displayed. Make the output settings in this area.	3.6
j	Soft-key function	Shows the functions assigned to the soft-keys on the right side of the screen.	3.3.3
k	Window	The window where the confirmation message is displayed or you change the settings. It is displayed as needed.	3.3.4

5.1.1 Status Icon

Table 5-2 shows icons displayed in specific states and their meanings.

Table 5-2 Status Icons



















Icon	Name	Meaning	Refer to
	Rated power	Indicates the maximum output power.	3.2.5
	AGC	The AGC setting is on.	4.12
	Autocal	The Autocal is on.	4.13
	Busy	The product does not accept key operations for changing the setting as it is performing the internal processing. Please wait for a moment.	–
	RMS current limiter	The RMS current limiter is activated.	4.1.2
	RMS voltage limiter	The RMS voltage limiter is activated.	
	Peak current limiter	The peak current limiter is activated.	4.1.1
	Peak voltage limiter	The peak voltage limiter is activated.	
	Active power Limiter	The wattage limiter is activated.	4.1.4
	Output relay control and high impedance output off	The background is white when output relay control is enabled, and black when it is disabled. The icon is OFF-L when the high impedance output off function is enabled, and OFF-H when it is disabled.	4.20, 4.21
	Output on/off phase setting and soft start/soft stop setting	These are the setting icons for the output on phase, output off phase, soft start, and software stop.	3.6.9, 3.6.10
	Key lock	The key lock is enabled.	4.23
	Remote	Displays the currently selected remote interface. In the local state, the icon is displayed in black. In the remote control state, the icon is lit in green.	6.

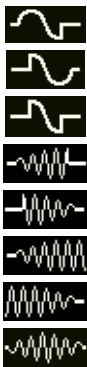
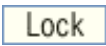

Table 5-2 Status Icons (Continued)

Icon	Name	Meaning	Refer to
	Editing	The edit view for the sequence or simulation is displayed.	4.2.13, 4.3.13
	Running	The sequence or simulation is running.	4.2.13, 4.3.13
	Stand by	The sequence or simulation stands by.	4.2.13, 4.3.13
	Sequence suspended	The sequence is suspended.	4.2.13, 4.3.13
	Unadjusted	Unadjusted. This icon means the abnormal state of the product. Contact us or our agent.	–

5.1.2 Measured Value Display Items

The items displayed in the measured value area are shown in *Table 5-3*.

Table 5-3 Measured Value Display Items

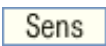
Item	Description
Icon 	With SYNC, the internal signal source is synchronized with the external signal or the power line. (See 4.19)
Icon 	With SYNC, the internal signal source is not synchronized with the external signal or the power line. (See 4.19)
Icon 	The Remote sensing function is enabled.
V *1	Output voltage
I *1	Output current
I _{PK-H}	Output current peak-hold value (CV mode)
V _{PK-H}	Output voltage peak-hold value (CC mode)
P	Output active power
S	Output apparent power
PF	Power factor of the output power
CF _I	Output current crest factor (CV mode)
CF _V	Output current crest factor (CC mode)

*1: For a polyphase system, the target output phase is displayed beside this.

For phase voltage display: L1-N, L2-N, or L3-N

For the line voltage: L1-L2, L2-L3, or L3-L1.

5.1.3 Output Setting Display Items

The items displayed in the output setting display area are shown in *Table 5-4*.

Table 5-4 Output Setting Display Items

Item	Description
Freq	Frequency of the output AC voltage
Wave	Waveform of the output AC voltage
ACV	Output AC voltage
DCV	Output DC voltage
Gain	Gain of the external signal
Source	Synchronization signal source

5.1.4 Warning and Error Display

If a warning or error occurs, an error message is displayed in the measured value area and the output display area. For details on error messages, see *8.1*.

5.2 Menu Composition

The menu composition of this product is shown in *Figure 5-2*. Press the MENU key to move to the root menu.

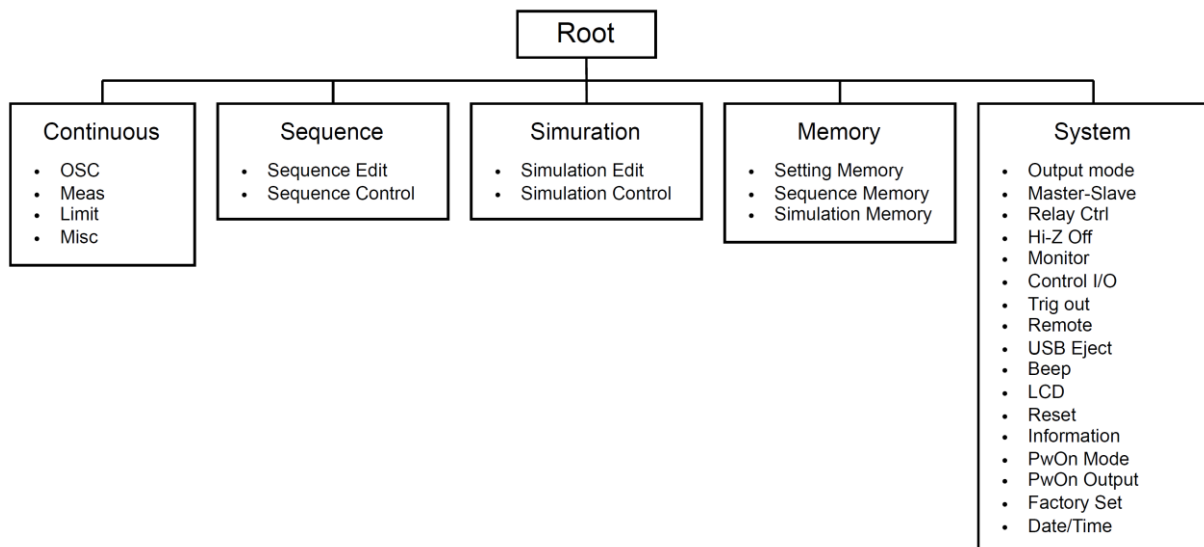

Figure 5-2 Menu Composition

5.2.1 Menus of the Continuous Function

The menus of the Continuous function are shown in *Table 5-5*. You can open each menu by using a soft-key.

Table 5-5 Menus of the Continuous Function

Menu		Description	Refer to	
OSC	OSC	Range	Switches the output voltage range.	3.6.2
		AC/DC	Switches the AC/DC mode.	3.6.1
		Source	Switches the signal source.	
		PhsMode	[Polyphase system] Switches between balanced mode and unbalanced mode.	4.15
		TargetPhs	[Polyphase system] Switches between the phase voltage setting and line voltage setting.	3.6.5
	On/Off Phs	OnPhs	Makes the on phase settings.	3.6.9
		OffPhs	Makes the off phase settings.	
	Soft Start/Stop	Soft Start	Sets the soft start.	3.6.10
Soft Stop		Sets the soft stop.		
Meas	TargetPhs	Switches the phase of the measurement value to display.	3.6.15	
	Rmt Sense	Sets the remote sensing function.	4.11	
	Type	Switches the type (effective value, average value, or peak) of the measurement value to display.	3.6.13	
	PK-H Clr	Clears the peak-hold value.	3.6.14	
	Harmonic	Displays the harmonic current measured values.	4.4	
Limit	PK Limiter	+Iop /-Iop	Sets the limit value of the peak current limiter.	4.1.1
		+Vop /-Vop	[In CC mode] Sets the limit value of the peak voltage limiter.	
		Output Off	You can set whether to make the output off or not upon the triggering of the peak limiter.	
		Time	Sets the limiter continuous operation time for when the output is turned off.	
	RMS Limiter	Io	Sets the limit value of the RMS current limiter.	4.1.2
		Vo	[In CC mode] Sets the limit value of the RMS voltage limiter.	
		Output Off	You can set whether to make the output off or not upon the triggering of the peak limiter.	
		Time	Sets the limiter continuous operation time for when the output is turned off.	
	Setting Range	V	Sets the setting range limit of the output voltage.	4.1.3
		I	[In CC mode] Sets the limit value of the setting range limit of the output current.	
		Freq UP Freq Lo	Sets the setting range limit of the output frequency.	
	Misc	Rmt Sense	Sets the remote sensing function.	4.11
AGC		Sets the AGC function.	4.12	
Aout Cal		Sets the Autocal function.	4.13	
DC Adj		Sets the DC offset adjustment.	4.14	

5.2.2 Menus of the Sequence Function

The menus of the Sequence function are shown in *Table 5-6*. You can open each menu by using a soft-key. For how to use the Sequence function, see *4.2*.

Table 5-6 Menus of the Sequence Function

Menu		Description	
Sequence Edit	Osc	Range	Switches the output voltage range.
		AC/DC	Switches the AC/DC mode.
	Limit	PK Limiter	Sets the peak limiter.
		RMS Limiter	Sets the RMS limiter.
	Misc	Rmt Sense	Sets the remote sensing function.
		Auto Cal	Sets the Autocal function.
		Trig Out	Sets the trigger output.
		Time Unit	Switches the time unit between ms and s.
	Compile	Compiles the edited sequence and moves to the Sequence Control View.	
	File	Saves to, recalls, clears, and renames the Sequence Memory.	
Clear	Resets the edited sequence to the factory default settings.		
Sequence Control	Start	Starts the sequence. It is displayed in the output on and sequence stopped states.	
	Stop	Ends the sequence. It is displayed in the sequence running state.	
	Hold	Suspends the sequence. It is displayed in the sequence running state.	
	Resume	Resumes the suspended sequence. It is displayed in the sequence suspended state.	
	Bran1	Branches to a step of the branch 1. It is displayed in the sequence running state.	
	Bran2	Branches to a step of the branch 2. It is displayed in the sequence running state.	
	Meas	Makes the measured value display settings. It is displayed in the sequence stopped state.	
	Edit	Displays the Sequence Edit View. It is displayed in the output off state.	

5.2.3 Menus of the Simulation Function

The menus of the Simulation function are shown in *Table 5-7*. You can open each menu by using a soft-key. For how to use the Simulation function, see 4.3.

Table 5-7 Menus of the Simulation Function

Menu		Description	
Simulation Edit	Osc	Range	Switches the output voltage range.
	Limit	PK Limiter	Sets the peak limiter.
		RMS Limiter	Sets the RMS limiter.
	Misc	Auto Cal	Sets the Autocal function.
		Trig Out	Sets the trigger output.
		Time Unit	Switches the time unit between ms and s.
	Compile		Compiles the edited simulation and moves to the Simulation Control View.
	File		Saves to, recalls, clears, and renames the Simulation Memory.
Clear		Resets the edited simulation to the factory default settings.	
Simulation Control	Start		Starts the simulation. It is displayed in the output on and simulation stopped states.
	Stop		Ends the simulation. It is displayed in the Simulation running state.
	Measure		Makes the measured value display settings. It is displayed in the simulation stopped state.
	Edit		Moves to the Simulation Edit View. It is displayed in the output off state.

5.2.4 Menus of the Memory Function

The menus of the Memory function are shown in *Table 5-8*. For how to use the Memory function, see 4.7.

Table 5-8 Menus of the Memory Function

Menu	Description
Setting Memory	Saves to, clears, and renames the Basic Setting Memory.
Sequence Memory	Saves to, recalls, clears, and renames the Sequence Memory.
Simulation Memory	Saves to, recalls, clears, and renames the Simulation Memory.

5.2.5 System menu

The System menus are shown in *Table 5-9*.

Table 5-9 System Menus

Menu	Description	Refer to
Output Mode	Switches the CV/CC mode.	3.7
Master- Slave	Enables/disables the master/slave functions.	3.4
Relay Cntrl	Enables/disables the output relay to coordinate with the output on/off.	4.20
Hi-Z Off	Enables/disables the high impedance off function.	4.21
Monitor	Makes the Monitor function settings.	4.10
Control I/O	Switches the control by the external control function to Enable/Disable.	4.18
Trig Out	Makes the trigger output settings in the Sequence and the Simulation.	4.2, 4.3
Remote	Makes the communication interface settings.	6.1
USB Eject	Disconnects the USB memory before removing it.	4.8
Beep	Turns the beep sound on or off.	4.24
LCD	Sets the screen color and the contrast.	4.25
Reset	Resets the system.	4.28.1
Information	Displays the system information.	9.4
PwOn Mode	Selects the output function (Continuous/Sequence/Simulation) at power-on.	4.2.11, 4.3.11
PwON Output	Enables/disables the function to turn on the output at power-on.	4.22
Shut Down	Enables/disables the shutdown function.	4.26
Factory Set	Restores the factory default settings.	4.28.2
Date/Time	Sets the date and time.	4.27

6. Remote Control

6.1	Communication Interface.....	176
6.2	Remote/Local State Switching.....	184

6.1 Communication Interface

This product is provided with the USB, RS232, GPIB and LAN communication interfaces as standard and is remote-controllable by a computer. The remote control allows almost all the operations available on the control panel to be performed. In addition, it can read the internal state such as setting values and errors. The command language is compliant with the SCPI Specification 1999.0.

Regardless of which communication interface is used, you can create and use a program that uses the Virtual Instrument Software Architecture (VISA) library. If you do not have a license to use VISA library, you need to obtain one (generally, it requires some cost).

For details of the remote control commands and programming, see “Instruction Manual (Remote Control).”

6.1.1 USB

This product is compliant with the USB Test and Measurement Class (USBTMC). Normally, the USBTMC class driver supports the sub class USB488 and can perform almost the same controls as GPIB on USB.

■ Preparation

The computer used for control needs a USBTMC class driver installed on it. The USBTMC class driver is included in the hardware and software product of each company that provides the VISA library.

■ Operation procedure

1. Press the MENU key to move to the root menu, and then select [System]. The system setting window opens.

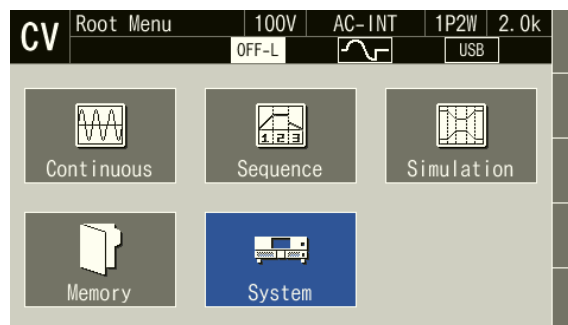

- Put the cursor on [Setup] next to the [Remote] item, then press the ENTER key. The remote setting window opens.

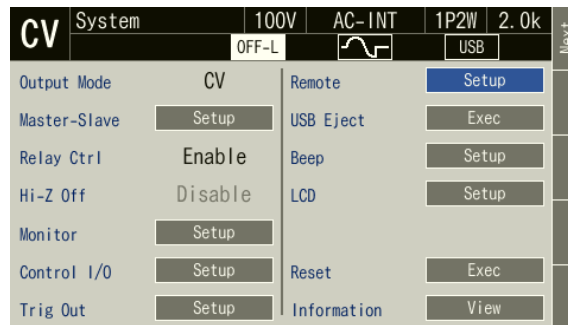

- In the [Interface] item, select [USB].

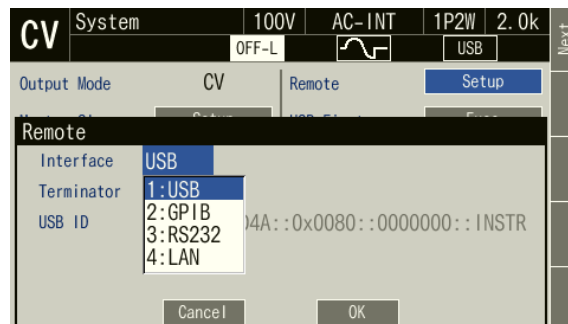

- The window shows [Terminator] and [USB ID]. For the USB ID, see the explanation in the next section. Select [OK] to close the window.

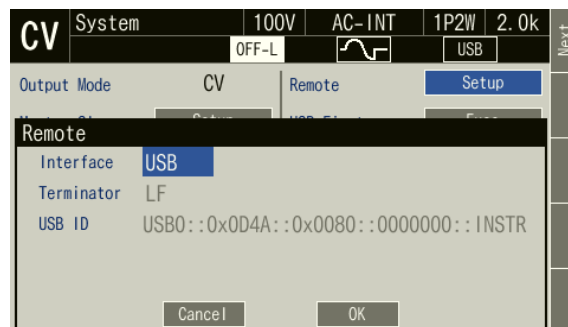

- Use a commercially available USB cable (Type A to B) to connect this product to the computer. USB connector is available on the rear of this product.

Notes

- Avoid use in a place under electrically noisy environment.
- It is recommended to use a fully-shielded, short cable.
- The use of USB hub may cause the product not to communicate properly.

■ About USB ID

Used to identify each product from the application when multiple DP020AGS units are connected through USB in the system. The USB ID is represented in the following format.

USB0::[Vendor number]::[Product number]::[Serial number]::INSTR

- Vendor number: Fixed to 3402 (0x0D4A)
- Product number: Fixed to 128 (0x0080)
- Serial number: A unique number (serial number) has been set for each product.

6.1.2 RS232

For the interface specifications, see 10.30.

■ Operation procedure

1. Press the MENU key to move to the root menu, and then select [System]. The system setting window opens.

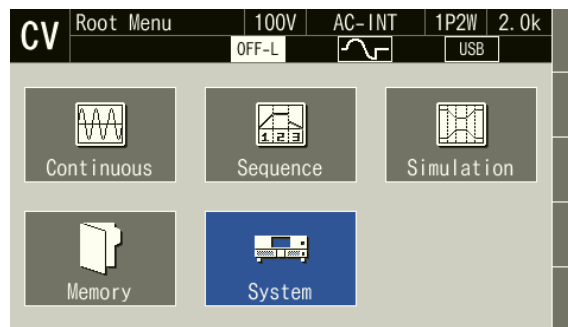

2. Put the cursor on [Setup] next to the [Remote] item, then press the ENTER key. The remote setting window opens.

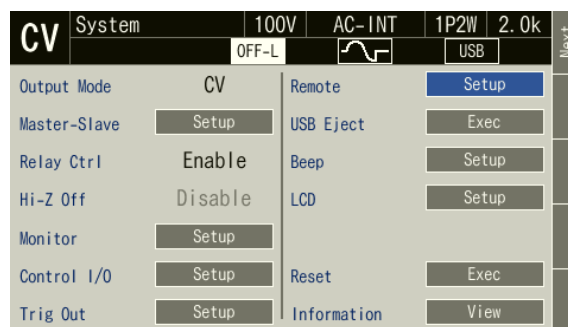

3. In the [Interface] item, select [RS232].

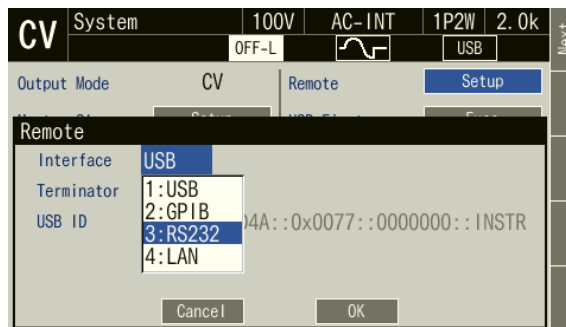

4. Set each item. Select [OK] after setting is complete.



5. Use a D-sub 9-pin cross cable to connect this product to the computer. RS-232 connector is available on the rear of this product.

----- Notes -----

- Avoid use in a place under electrically noisy environment.
 - Turn off this product and the computer before connecting or disconnecting the cable.
 - Binary transmission is not supported.
-

6.1.3 GPIB

This product is compliant with the GPIB IEEE Standard 488.1-1987. The GPIB-based remote control is available. For the interface specifications, see 10.30.

■ Operation procedure

1. Press the MENU key to move to the root menu, and then select [System]. The system setting window opens.

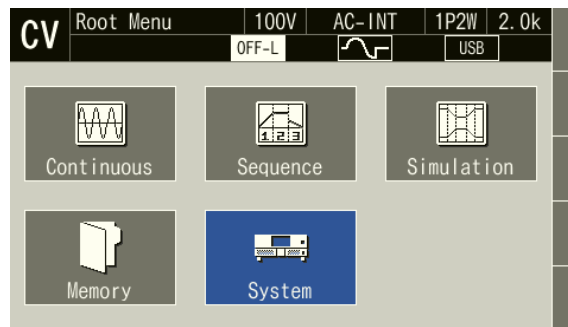

2. Put the cursor on [Setup] next to the [Remote] item, then press the ENTER key. The remote setting window opens.

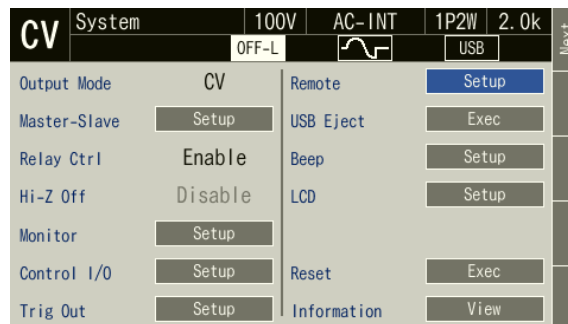

3. In the [Interface] item, select [GPIB].

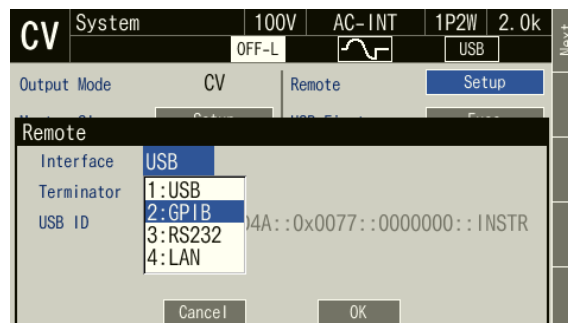

- [Terminator] is fixed to “LF”. In the [Address] item, set the address. Select [OK] after setting is complete.

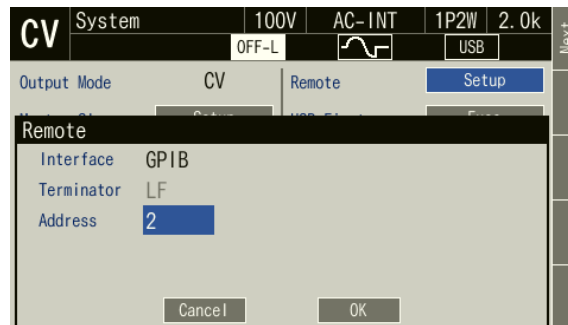

- Use a GPIB cable to connect this product to the computer. GPIB connector is available on the rear of this product. Turn off this product and the computer before connecting or disconnecting the cable.

----- Notes -----

- Avoid use in a place under electrically noisy environment.
 - Before connecting or disconnecting the cable, turn off the power to all devices on the bus.
 - When using the GPIB, turn on the power to all devices on the bus.
 - Ensure that the total cable length is within 20 meters.
 - Ensure that the length of one cable is within 4 meters.
 - Do not set the same address as the one used for any other device connected to the same bus. Otherwise, the product cannot communicate properly.
-

6.1.4 LAN

For the interface specifications, see 10.30. For how to set LAN interface, refer to the Instruction Manual (Remote Control).

■ Operation procedure

1. Connect this product and computer with LAN cable. LAN connector is available on the rear of this product. Turn off this product and the computer before connecting or disconnecting the cable.
2. Press the MENU key to move to the root menu, and then select [System]. The system setting window opens.

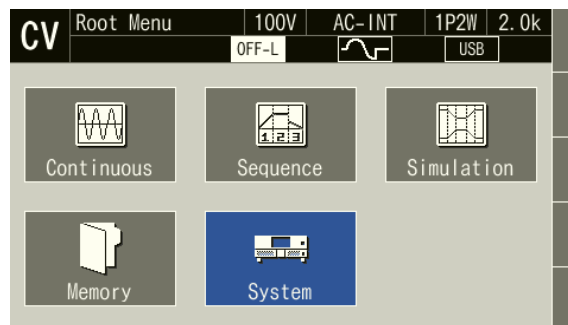

3. Put the cursor on [Setup] next to the [Remote] item, then press the ENTER key. The remote setting window opens.

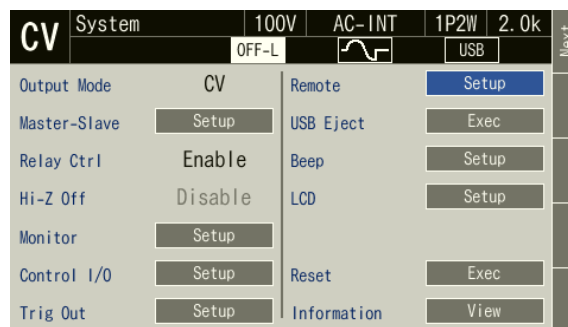

4. In the [Interface] item, select [LAN].

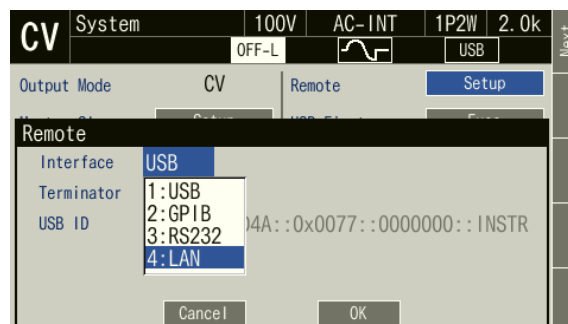

5. The current [MAC Address], [IP Address], [Subnet mask] and [Gateway] are displayed. To use a static IP address, set the [DHCP] item to [1: Disable]. To not use a static IP address, set the [DHCP] item to [2: Enable]. [Terminator] is fixed to LF. Select [OK] after setting is complete.

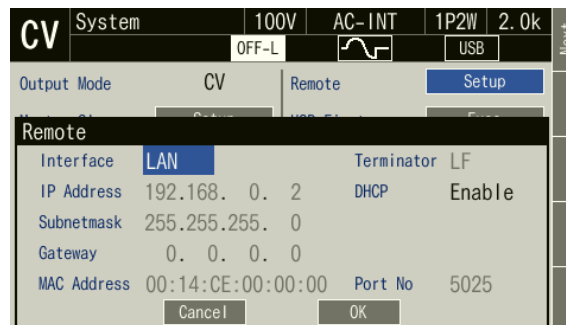

MAC Address: Device-specific address (physical address). It cannot be changed. It is 8 bit delimited, hexadecimal notation.

IP Address: In IP (Internet Protocol), you can check the address (logical address) for identifying the device. The range from 192.168.0.0 to 192.168.255.255 is a private IP address that you can freely use in a small local network (Class C).

Subnetmask: You can check the mask that separates the upper network address and the lower host address from the IP address.

Gateway : When accessing an external network, you can check the IP address of the gateway (repeater) to use implicitly.

6. When not using a static IP address, the remote icon will be blank immediately after switching the interface. When communication becomes possible, the LAN icon is displayed. See the Instruction Manual (Remote Control).





Notes

- Avoid use in a place under electrically noisy environment.
- Turn off this product and the computer before connecting or disconnecting the cable.
- Binary transmission is not supported.

6.2 Remote/Local State Switching

6.2.1 Remote state

In the Remote state, the control panel key operations are not accepted. However, the output off (OUTPUT key) and the switching to the Local state ( + ) are accepted.

■ Switching to the Remote state

When communication is established after the command is sent from the computer to this product, this product switches to the Remote state.

6.2.2 Local State

Control panel key operations are accepted.

■ Switching to the Local state

The Shortcut operation  +  switches to the state to Local.

7. Options

7.1	System Cable (for Multi-unit system)	186
7.2	Rack-Mount Adapter	186
7.3	Replacement Air Filter	190
7.4	Power Cable	190

7.1 System Cable (for Multi-unit system)

This cable is used to configure a multi-unit system by connecting multiple DP020AGS. This option can be requested at the time of order or added after the purchase. For how to configure a multi-unit system, see 2.5.2 and 3.4.

Table 7-1 System Cable Model Names

Model name	Product name
PA-001-3879	System Cable (0.5 m)
PA-001-3880	System Cable (1 m)
PA-001-3881	System Cable (2 m)

7.2 Rack-Mount Adapter

The rack-mount adapter is a set of brackets used to mount the product on the EIA or JIS standard compliant rack. This option can be requested at the time of order or added after the purchase.

Table 7-2 Rack-Mount Adapter Model Names

Model name	Product name
PA-001-3882	Rack-mount adapter (inch)
PA-001-3883	Rack-mount adapter (mm)

See *Figure 7-1*, *Figure 7-2*, *Figure 7-3*, and *Figure 7-4*, and then attach the adapter.

When storing the product in a rack, do not use only the rack-mount adapter to hold the main unit in place. Be sure to provide L-shaped brackets or a shelf on the rack side to hold the main unit in place.

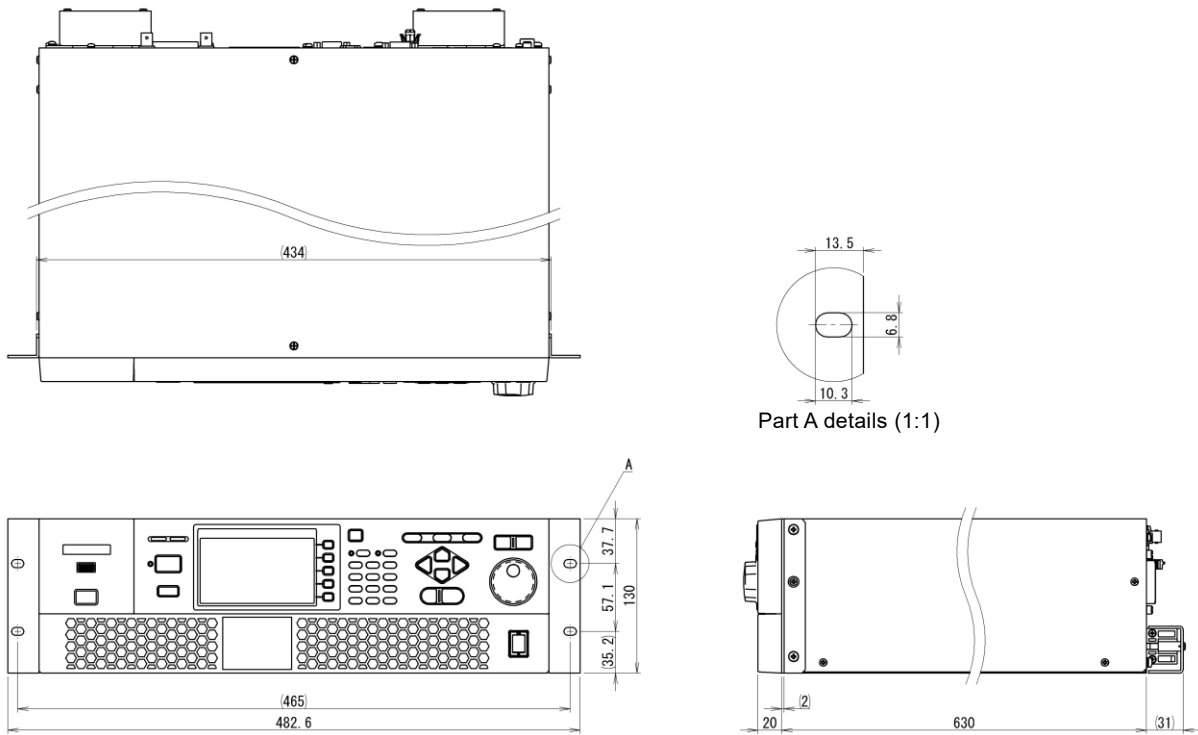

Figure 7-1 Outline Dimensional Drawing (Rack-mount Adapter [inch])

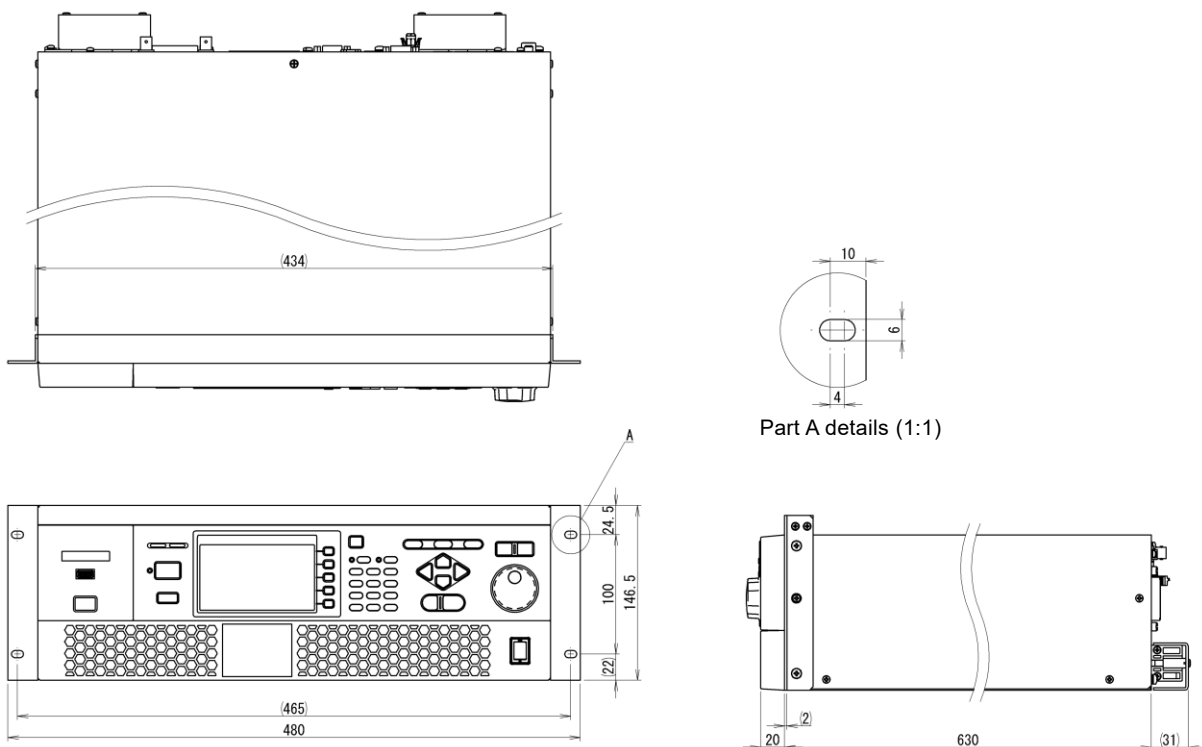

Figure 7-2 Outline Dimensional Drawing (Rack-mount Adapter [mm])

7. Options

Part No	Name	Qty
①	Rack mount, EIA, L	1
②	Rack mount, EIA, R	1
③	Countersunk machine screw (M4×8)	4

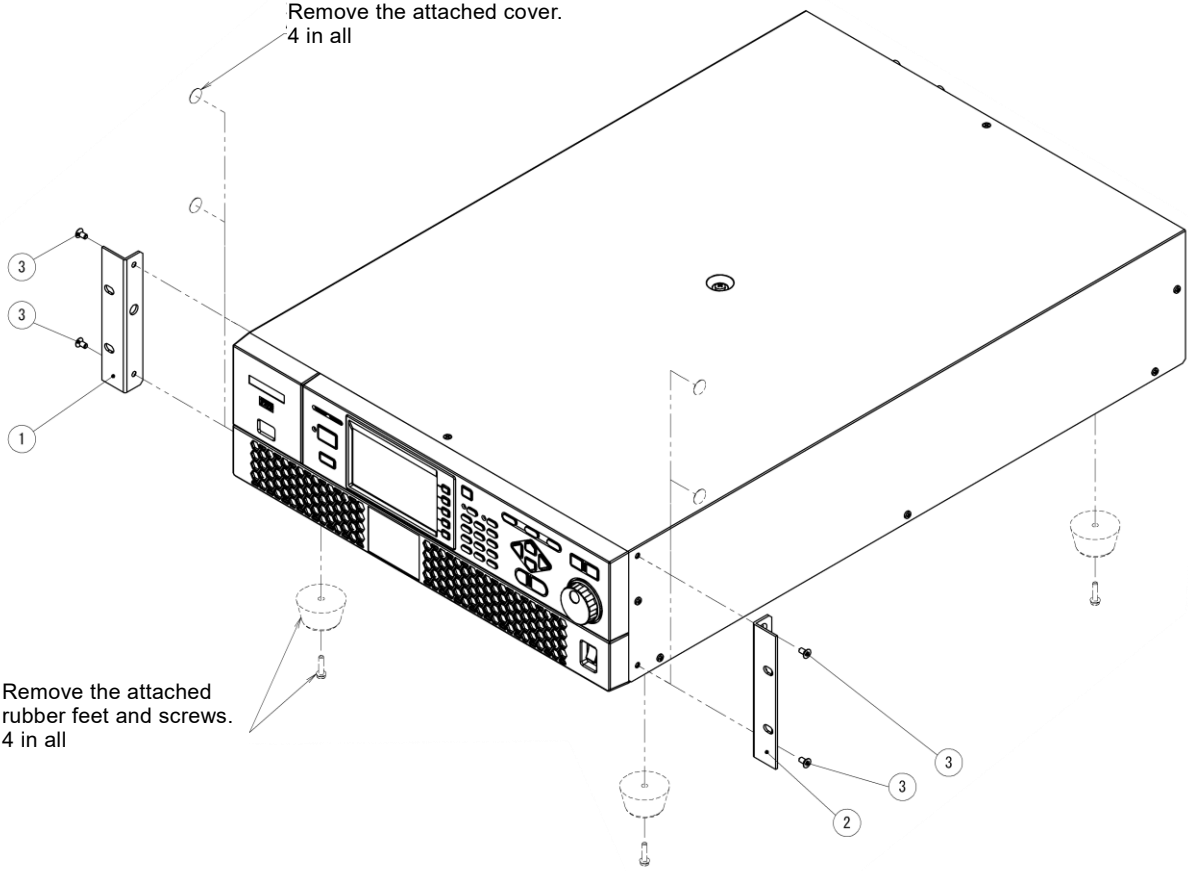

Figure 7-3 Assembly Diagram (Rack-mount Adapter [inch])

Part No	Name	Qty
①	Rack mount, EIA, L	1
②	Rack mount, EIA, R	1
③	Rack-mount JIS spacer	1
④	Countersunk machine screw (M4×8)	4
⑤	Countersunk machine screw (M3×8)	4

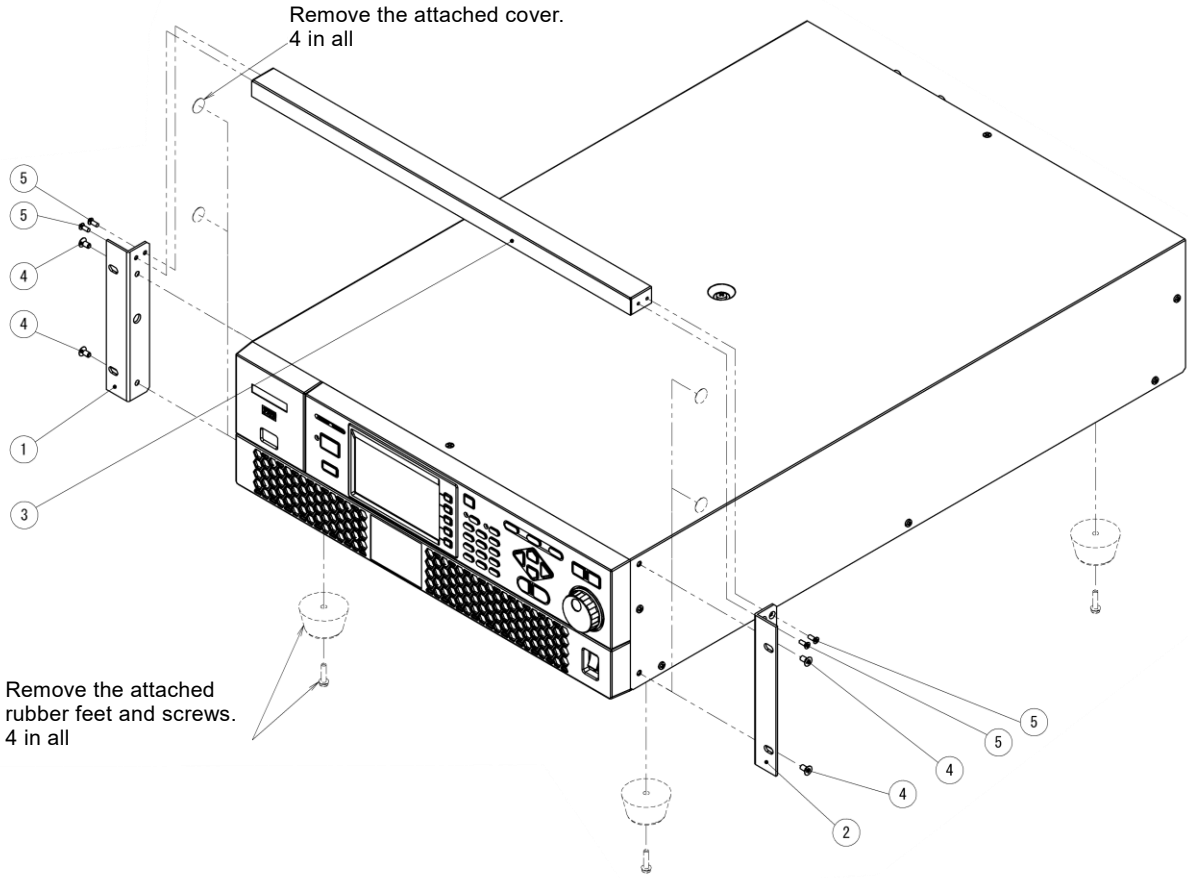

Figure 7-4 Assembly Diagram (Rack-mount Adapter [mm])

7.3 Replacement Air Filter

A set of replacement air filters on the front grill. This option can be requested at the time of order or added after the purchase. For how to replace the air filters, see 9.2.

Table 7-3 Replacement Air Filter Model Names

Model name	Product name
PA-001-3884	Replacement air filter

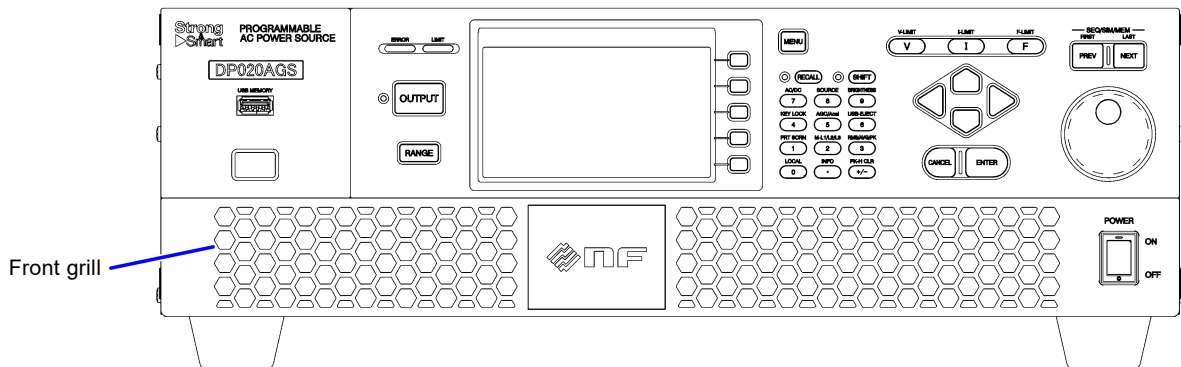

Figure 7-5 Front Grills

7.4 Power Cable

Cables for the power input. It can be requested at the time of order or added after the purchase.

The thickness, which is in accordance with the power input and rated output, is shown in *Table 7-4*. The cable has a crimp-type terminal attached to the end that is to be connected to the input terminal of this product. The length of the cable is 3 m.

- On the power cable, the end which is to be connected to the distribution board has no terminal attached. Use a crimp-type terminal appropriate for the terminal screw diameter of the distribution board to connect the cable firmly.
- The power cable is dedicated only to this product. Do not use it with any other product.

Table 7-4 Power Cable Model Names

Model name	Rated output power	Maximum power consumption	Terminal size	Nominal cross sectional area
PA-001-3885	2.0 kVA	2.65 kVA	M5	14 mm ² approx

8. Troubleshooting

8.1	Error Messages and Error Handling.....	192
8.2	When a Failure is Suspected.....	198

8.1 Error Messages and Error Handling

8.1.1 Error Message Screen

An error message screen opens as shown in *Figure 8-1*, for example, in case that the protection function is activated. The description of each item is shown in *Table 8-1*.

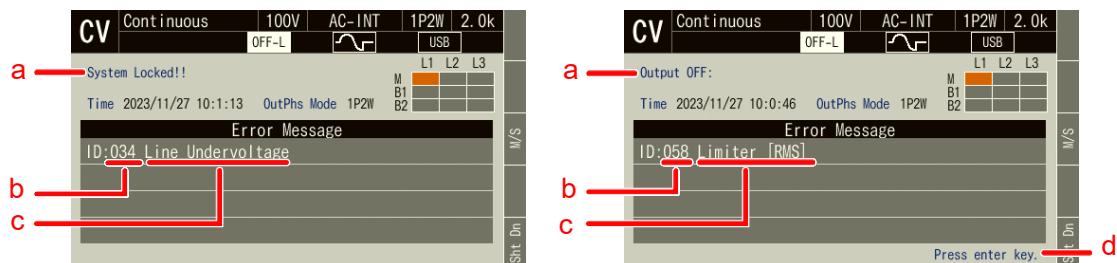

Figure 8-1 Error Message Screen Example

Table 8-1 Description of the Error Message Screen

Symbol	Name	Description	Refer to
a	Protection type	System Locked: System Lock Output OFF: Output off	8.1.3
b	Error ID	The number to identify an error.	8.1.4
c	Message	Describes the error details.	8.1.4
d	Press Enter Key View	Displayed for an error whose protection type is Output Off.	8.1.2

8.1.2 If An Error Message is Displayed

If an error message is displayed, handle it by the following procedure.

■ Handling procedure

1. Check on the error content and remove the reason of the error. For each message and its handling method, see *8.1.4*.
2. When the protection type says System Locked, cycle the power of the product.
3. When the protection type says Output OFF, press the ENTER key. The error message disappears.
4. Now the product is available.

8.1.3 Protection Operation Types

When the protection function is activated or an error is detected, the product applies one of the following five types of protection operation and error message, according to the error level.

- **System Lock**

No operations are accepted on the control panel. The panel says “System Locked.” To operate the product again, it is necessary to cycle the power of it.

- **Output Off**

The output turns off. The panel says “Output OFF” and “Press Enter Key.” When you press the ENTER key, you will return to the previous window for further operations if the cause of the error has been removed. Otherwise, the error message window will be displayed again.

- **Message display only**

The output state remains unchanged. The panel shows the error message window. Press the ENTER key to return to the previous screen for further operations.

- **Limiting action**

The output is limited. The panel shows the icon indicating the limiting action, without an error message. In addition, the LIMIT LED illuminates on the front panel. The output turns off after a given period according to the limiter setting. In this case, an error message appears after the output off.

- **Icon display**

The output state remains unchanged. The panel shows an icon instead of an error message. The panel operation is available as usual.

8.1.4 Error Message List

Error messages are listed in *Table 8-2*.

Table 8-2 Error Message List

ID	Message	Protection type	Cause or Necessary action
2	Invalid in This Output Mode	Message display only	This output mode does not allow the setting (execution). Change the output mode.
3	Invalid with Output ON	Message display only	The output on state does not allow the setting (execution). Turn the output off, then set (execute).
4	Invalid with Output OFF	Message display only	The output off state does not allow the setting (execution). Turn the output on, then set (execute).
5	Busy	Message display only	The busy state does not allow the setting (execution). Execute after the busy icon disappears.
6	Invalid with Remote Control	Message display only	The remote control state does not allow the setting (execution). Bring the state to local control, then set (execute).
11	Under Error State	Message display only	The protection operating state does not allow the setting (execution). Cancel protection, then set (execute).
13	Auto Cal Disabled	Message display only	The Autocal setting becomes off because of out of the calibration range.
15	AGC Disabled	Message display only	The AGC setting becomes off because of out of the calibration range.
16	Invalid in Sequence Edit	Message display only	The sequence editing state does not allow the setting (execution). Switch to the sequence control view, then set (execute).
17	Invalid in Sequence Control	Message display only	The sequence execution state does not allow editing. Switch to the sequence edit view, then edit.
18	Invalid in Simulation Edit	Message display only	The simulation editing state does not allow the setting (execution). Switch to the simulation control view, then set (execute).
19	Invalid in Simulation Control	Message display only	The simulation execution state does not allow editing. Switch to the simulation edit view, then edit.
20	Invalid	Message display only	The condition cannot be set (executed).
23	Option not Installed	Message display only	Setting (execution) is not allowed because CC mode (custom), etc. is not installed.
24	USB Memory Unconnected	Message display only	No USB memory is connected. Connect a USB memory.
25	USB Memory Removed illegally	Message display only	The USB memory was removed before the eject operation. Perform the eject operation before removing a USB memory.

Table 8-2 Error Message List (Continued)

ID	Message	Protection type	Cause or Necessary action
26	USB Memory Access Error	Message display only	The USB memory has an access error.
27	Too Many Files	Message display only	There are too many files in the USB memory. Each folder can contain 500 files or less.
28	Out of Measurement Range	Message display only	The measurable range has been exceeded.
29	Sync Frequency Unlocked	Message display only	The output cannot be turned on because of not locking to the synchronization frequency.
31	Configure Memory Error	Message display only	The internal memory has an error.
33	Line Overvoltage	System Lock	The power input voltage is excessive. Check if the power input is appropriate.
34	Line Undervoltage	System Lock	The power input voltage is insufficient. Check if the power input is appropriate.
36	Communication Failure Power Unit	System Lock	There is a communication error between the firmware and the power unit. Cycle the power. If it still occurs, contact the seller (NF Corporation or our agent) from whom you purchased the product.
37	Internal Communication Failure	System Lock	There is an internal communication error. Cycle the power. If it still occurs, contact the seller (NF Corporation or our agent) from whom you purchased the product.
38	Communication Failure Between Cabinets	System Lock	There is a multi-unit system communication error. Make sure the System Cable is connected properly.
41	Mismatched Firmware Versions	System Lock	In a multi-unit system, the main firmware versions of the units do not match.
42	Mismatched Internal Versions	System Lock	The firmware versions of the internal modules do not match.
43	Mismatched Pair of HW/SW Versions	System Lock	The internal board version and firmware version do not match.
44	Unsupported Power Unit Version	System Lock	A power unit of unsupported version is connected.
45	Mismatched Cabinet Connect	System Lock	In a multi-unit system, the system configuration is out of spec. Check the number of units comprising the multi-unit system and whether any models other than DP020AGS are connected. Furthermore, if there is a unit for which the system cable connection and the master slave setting do not match, the entire multi-unit system cannot start up. Check the master/slave setting of each unit. see 3.4.2, 3.4.3.
48	Output Overvoltage	Output off	The output voltage is excessive. This may occur at an abrupt change in the output current due to the inductive load.

Table 8-2 Error Message List (Continued)

ID	Message	Protection type	Cause or Necessary action
50	Output Overcurrent [RMS]	Output off	The output current RMS value is excessive on a module in the power unit. This may occur when the output terminal is short-circuited.
51	Output Overcurrent [Peak]	Output off	The output current peak value is excessive.
52	Power Unit DCPS Error	Output off	The DC power supply in the power unit is abnormal.
53	Power Unit DCPS Overvoltage	Output off	The voltage of the DC power supply in the power unit is excessive. This may occur when the power flows back from the load.
54	Power Unit DCPS Undervoltage	Output off	The voltage of the DC power supply in the power unit is insufficient. This may occur when the overload output activated the protection function on the DC power supply.
55	Overheat	Output off	The temperature in the power unit is abnormally high. Check if the ambient temperature is appropriate. Check the filters for clogging. For filter cleaning, see 9.2.
56	Sensing Voltage Error	Output off	The sensing voltage is abnormal. Make sure the cable is properly connected to the voltage sensing terminal.
57	Sync Frequency Error	Output off	The frequency went out of the synchronizable range, and thus the output turned off.
58	Current Limiter [RMS]	Output off	The RMS current limiter was activated, and thus the output was turned off according to the setting.
59	Current Limiter [Peak]	Output off	The peak current limiter was activated, and thus the output was turned off according to the setting.
60	Power Unit Internal Error	Output off	This is a power unit internal error. If it occurs repeatedly, contact the seller (NF Corporation or our agent) from whom you purchased the product.
61	↑WAT	Limiting action	The wattage limiter is activated.
62	↑I _{rms} , ↑V _{rms}	Limiting action	The RMS current limiter or RMS voltage limiter is activated.
63	↑I _{pk} , ↑V _{pk}	Limiting action	The peak current limiter or peak voltage limiter is activated. The internal operation differs from that for ID 64.
64	↑I _{pk}	Limiting action	The peak current limiter is activated. The internal operation differs from that for ID 63.

Table 8-2 Error Message List (Continued)

ID	Message	Protection type	Cause or Necessary action
67	Battery Depleted	Message display only	The built-in battery has depleted. Contact the seller (NF Corporation or our agent) from whom you purchased this product.
68	Current Parameters Rounded	Message display only	When the output parameters read from the memory do not match the number of currently connected units, the output parameter are set to the initial values and a message is displayed.
69	Multi-Unit System Connection Updated	Message display only	The multi-unit system is detected that is different from the previous one.
70, 71	Unca	Icon display	The power unit or the system has not been adjusted.
75	Calibration Data Error in Control Unit	Message display only	The adjustment data is abnormal.
76	Property Data Error in Control Unit	Message display only	The property data is abnormal.
77	USB Memory Connected	Message display only	A USB memory was inserted.
78	USB Memory Disconnected	Message display only	The USB memory eject operation was performed, and thus the USB memory can be removed now.
80	Invalid Character	Message display only	An invalid character has been used for the file name of memory.
82	Sequence Compile Error	Message display only	Sequence compilation failed.
83	Simulation Compile Error	Message display only	Simulation compilation failed.
84	System Updated Please Reboot	System Lock	The firmware was updated.
88	Auxiliary Power Failure	System Lock	An internal auxiliary power failure was detected.
90	Mismatched System Setting	System Lock	In a multi-unit system, a system setting mismatch has occurred between the units.
91	Shut Down	Shutdown	The shutdown function operated.
99	Output OverPower	Output off	Output overpower protection activated, and the output turned off.
-200	EXECUTION ERROR	Message display only	The panel operation (or remote command) could not be executed.
-	No screen display All LEDs on the panel are lit.	System Lock	There is an internal ROM error.
-	No screen display All LEDs on the panel are lit.	System Lock	There is an internal RAM error.

8.2 When a Failure is Suspected

When a symptom occurs that suspects a failure, take an action according to *Table 8-3*. If it does not solve the problem, contact the seller (NF Corporation or our agent) from whom you purchased the product.

Table 8-3 Actions When a Failure is Suspected

Category	Symptom	Possible cause	Necessary Actions
Problem at power on/off	The product does not start operating when the power switch is turned on.	The power is not connected.	Connect the product to the power supply. →2.4
		The power supply is out of the rated range.	Use the power supply within the rated range. →2.4
		The internal fuse is blown.	Ask us or our agent for repair.
	The product does not stop immediately when the power switch is turned off.	It is not abnormal. The product automatically stops after the internal voltage decreases to a sufficiently safe level.	Please wait for a moment. It will stop in about ten seconds.
Problem at key operation	Panel operations cannot be performed.	The key lock is set to on.	Set the key lock to off. →4.23
		Keys or dials are deteriorated.	Ask us or our agent for repair.
	Numerical values cannot be entered through the numeric keypad.	In the shift state (the LED beside the SHIFT key LED is lit). Or, in the RECALL state (the LED beside the RECALL key is lit).	Press the SHIFT key to exit from the shift state. Or, press the RECALL key to exit from the RECALL state. →3.3.7
Problem at output setting	At start-up, the previous settings are not kept.	They are not saved in the setting memory No. 1.	At start-up, the settings in the setting memory No. 1 are recalled. →4.7.3
	The output voltage range cannot be switched.	The output is on.	Turn the output off before switching the output voltage range. →3.6.2
	The output voltage cannot be set.	The signal source is set to VCA.	Change the signal source. →3.6.1
		You are trying to set a value that is out of the setting range.	Check for the voltage setting range limit (→4.1.3).
	The output frequency cannot be set.	The signal source is set to SYNC.	This value cannot be set when the signal source is SYNC. Change the signal source. →3.6.1
		You are trying to set a value that is out of the setting range.	Check for the frequency setting range limit (→4.1.3c)).

Table 8-3 Actions When a Failure is Suspected (Continued)

Category	Symptom	Possible cause	Necessary Actions
Problem at output setting	The line synchronization cannot be set.	The signal source is not set to SYNC.	Set the signal source to SYNC and the external synchronization signal source to LINE. →4.19
	The output on state cannot be achieved.	An error message is on-screen.	The output cannot be turned on while there is an error message. If the protection function is activated, remove the cause (→8.1.2). Press the ENTER key to clear the error message. When the message says “System Locked”, cycle the power.
Output-related problem	The output voltage does not come up.	The state is the output off (the OUTPUT key LED illuminates)	Press the OUTPUT key to turn the output on.
		The output voltage is set to zero.	Check for the output voltage setting. →3.6.4, 3.6.5
		The external signal source is not connected.	When the signal source is VCA, connect the signal source to the external signal input terminal, and set the external input gain appropriately. →4.17
		The external input gain is zero.	
	The measured voltage is different from the setting value.	Unnecessary items are set (for example, the AC voltage setting remains for the DC output).	Check for the setting again.
		The limiter is activated (the limiter icon is displayed).	For a load with lower impedance, the limiter is activated to make the output lower than the setting value. Check on the limiter setting. →4.1
Output-related problem	The measured voltage is different from the setting value.	The waveform is set to CLP (clipped sine wave) and the Type is set to Clip (specified clip ratio mode).	In the specified clip ratio mode, the output voltage setting means a value for the waveform before being clipped. To set a value for the clipped waveform, set the Type to the specified crest factor mode (Type: CF). →4.6
		An error message is displayed.	The protection function was activated due to overload.
	The ambient temperature is high.		Decrease the ambient temperature when using the product. The maximum current may decrease over 40 °C.
	Air filters are clogged.		Clean the air filters by referring to 9.2.
	Around the front panel air inlet or rear panel air outlet, there is something blocking the air flow.	Install the product so as to satisfy the installation conditions described in 2.2.	

Table 8-3 Actions When a Failure is Suspected (Continued)

Category	Symptom	Possible cause	Necessary Actions
Measurement function-related problem	The measured voltage or current is not displayed correctly.	The display selection is not right.	Select RMS for AC. Otherwise, the correct value is not displayed.
	The measured value is displayed as "-- --".	It is out of the synchronization frequency measurement display range.	Set the synchronization signal source frequency to a value within the synchronization frequency measurement display range. → 10.15
	The measured value fluctuates.	A low frequency (less than 40 Hz) is set.	For a frequency lower than 40 Hz, the measurement cycle is a fixed value and thus the measured value may not be stable.
Limiter/setting range limitation-related problem	The output current peak-hold value (measured) is larger than the peak current limiter setting value.	The output current overshoot occurred for the limit value.	While the peak current limiter is activated, the overshoot may occur depending on the load. → 4.1.1
Remote sensing problem	The Remote sensing function cannot be turned on.	The output mode is incorrect.	The Remote sensing function can be turned on only when corresponds to Table 4-10 . It is turned off when the Sequence or Simulation function is selected. However it can be set to ON in the AC-INT, ACDC-INT and DC-INT modes and when the waveform is a sine wave or DC in case the stand-by state of Sequence mode (step0). In the ACDC it cannot be set to ON unless either AC voltage or DC voltage setting is 0 V. → 4.11
		The waveform setting is incorrect.	
		The mode is not the Continuous mode.	
		The mode is not the stand-by state of Sequence mode.	
		In the stand-by state of Sequence mode (step0) and ACDC either AC voltage or DC voltage setting is not 0 V.	

Table 8-3 Actions When a Failure is Suspected (Continued)

Category	Symptom	Possible cause	Necessary Actions
Problem of AGC function	The AGC function cannot be turned on.	The output mode is incorrect.	The AGC function can be set to on in the AC-INT, AC-VCA, AC-SYNC, DC-INT, and DC-VCA modes. However, for the AC, it can be set to on only when the waveform is a sine wave. It is turned off when the Sequence or Simulation function is selected. →4.12
		The waveform setting is incorrect.	
		The mode is not the Continuous mode.	
		The Autocal function is on.	When the Autocal function is on, the AGC function cannot be used. Turn off the Autocal function. →4.13
Problem of Autocal function	The Autocal function cannot be turned on.	The output mode is incorrect.	The Autocal function can be turned on only when corresponds to <i>Table 4-10</i> . It is turned off when the Sequence or Simulation function is selected. However it can be set to ON in the AC-INT, ACDC-INT and DC-INT modes and when the waveform is a sine wave or DC in case the stand-by state of Sequence mode (step0). In the ACDC mode it cannot be set to ON unless either AC voltage or DC voltage setting is 0 V. →4.13
		The waveform setting is incorrect.	
		The mode is not the Continuous mode.	
		The mode is not the stand-by state of Sequence mode.	
		In the stand-by state of Sequence mode (step0) and ACDC either AC voltage or DC voltage setting is not 0 V.	
		The AGC function is on.	When the AGC function is on, the Autocal function cannot be used. Turn the AGC function off. →4.12
Problem of remote control	See the Instruction Manual (Remote Control).		
Problem of CONTROL I/O	The product cannot be controlled by the CONTROL I/O.	The external control is disabled.	Enable the external control. →4.18
		The Remote state is set by the communication interface.	The external control is disabled in the Remote state.

Table 8-3 Actions When a Failure is Suspected (Continued)

Category	Symptom	Possible cause	Necessary Actions
Problem of USB memory	Files in the USB memory do not appear on the screen.	USB eject operation was performed.	Perform the USB eject operation (4.8) again just in case, and remove the USB memory. Reconnect the USB memory and make sure the file names are displayed.
		One folder contains over 500 files.	Reduce the number of files in a folder to 500 or less.
		The format is illegal.	Use a FAT32-formatted USB memory.
Problem at driving an inductive load (e.g., transformer)	The current waveform is abnormal (e.g., asymmetrical or excessive) when the transformer is connected as the load and the AC voltage is output.	The output offset voltage (DC component) caused the load transformer core to reach the magnetic saturation.	In the AC, the control function works to eliminate the offset voltage (DC component). When the product is used in the ACDC, switch it to the AC (→3.6.1). If it does not bring much improvement, adjust the DC offset (→4.14).
	The output overvoltage error occurs for an inductive load (e.g., transformer).	An abrupt change in the output current generated a back electromotive force.	When the output is off or the peak current limiter is activated, the load current may change abruptly, which generates a back electromotive force to cause the output overvoltage error. To avoid the abrupt current change, reduce the setting value of the peak current limiter sufficiently for a smaller output current, or conversely set it to a sufficiently large value to disable the limiter to be activated, or sufficiently reduce the amplitude before turning off the output. →4.1.1
Memory function-related problem	The memory cannot be recalled.	The output is on.	The output on state does not allow the recall. Turn the output off.

Table 8-3 Actions When a Failure is Suspected (Continued)

Category	Symptom	Possible cause	Necessary Actions
Sequence/ Simulation- related problem	The Sequence cannot be started.	The output is off.	Turn on the output, then start the sequence.
	The specified Step Time is exceeded.	The Stop Phase is enabled.	When the Stop Phase setting is active, the execution waits for the Step Time that was set pass, and keeps the output setting until it reaches the Stop Phase that was set, and then transitions to the next step. As the result, the actual Step Time is longer than the set Step Time. To move to the next step immediately after the Step Time, disable the Stop Phase. →4.2
Problem of multi-unit system	The multi-unit system is not recognized at start-up.	The System Cable is not connected properly.	Check the System Cable connection for any disconnected connector, and so on. →2.5.2
		The master/slave setting is not set properly.	If there is a unit for which the system cable connection and the master slave setting do not match, the entire multi-unit system cannot start up. Check the master/slave setting of each unit. →3.4.2, 3.4.3
		Different models are connected.	If a model any other DP020AGS is in the multi-unit system configuration, the entire multi-unit system cannot start up.

9. Maintenance

9.1	Preface.....	206
9.2	Daily Maintenance	206
9.3	Repacking and transportation.....	207
9.4	Product Information Display	208

9.1 Preface

This chapter describes the following.

- daily maintenance
- cautions and storing for nonuse over a long period
- cautions and repackaging for transportation.
- checking firmware version

For the simple operation check, see 2.6.

9.2 Daily Maintenance

The product shall be installed in a location that satisfies the installation conditions (see 2.2).

■ When the panel or case is dirty

Wipe it with a soft cloth. If the dirt is heavy, wipe it with a cloth wrung out with diluted neutral detergent solution.

 **CAUTION**

- Do not use solvents (thinners, benzine, etc.) or wipes. Otherwise, the surface may be altered or the coatings may be peeled off.
-

■ When the front grill air filters are dirty

A front grill is provided with air filters for removing dust or dirt from the intake air. Clogged air filters deteriorate the ventilation, resulting in excessive high temperature inside the product. This may activate the overheat protection, affecting the operation, or damage the internal parts, resulting in failure. Regularly check the air filters for dirt, about once a month. If air filters are found dirty, rinse with water to remove the dirt, dry completely, then remount them. You can optionally request additional air filters for replacement (see 7.3).

 **CAUTION**

- Do not install the product in a place with a large amount of extremely fine dust (e.g., powders). The air filters may not fully work.
 - Do not install the product in a damp place prone to dew. The air filters are more likely to be clogged.
-

 **WARNING**

- Before removing the air filters and the front grill, be sure to cut the power to the distribution board. Otherwise, an electric shock might occur.
-

The air filters can be removed by the steps described below. In order to remount them later, check on the top and bottom of the front grill and the mounting position of the air filters as you remove them.

1. The front grill is fixed to the chassis at one point each on the left and right. Hold it at the left and right sides, and pull it out toward you to remove it.
2. Remove the air filter from the back of the front grill. Be careful with the small claws on the front grill that hold the air filters.

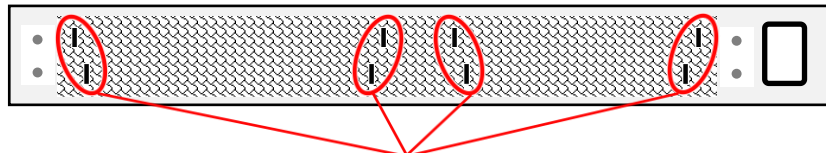

Be careful of the protrusions on which the air filter is hooked.

3. Rinse the removed air filters with water to remove dirt and clog. Dry them completely.
4. Remount them in reverse order of steps 1 to 2.

⚠ WARNING

- While removing the air filters and the front grill, do not supply the power from the distribution board. Otherwise, an electric shock might occur.

9.3 Repacking and transportation

This product shall be stored in a location that satisfies the installation conditions (see 2.2).

■ Storage when unused for a long time

- Remove the power cable from the distribution board and the product.
- Store the product in a place with no falling object or dust. If it may be covered with dust, put the cover, such as cloth and polyethylene sheet, on it.
- Avoid a place exposed to rapid temperature change or direct sunlight. Store it under a normal temperature environment wherever possible. For the storage condition, see 10.34.

■ Repackaging and transportation

Follow the instructions below when repackaging the product due to transfer or repair.

- In order for the main unit to be sufficiently protected from impact during transportation, pack it with a shock absorber such as AirCap.
- When requesting transportation, instruct the carrier that this product is a precision equipment.
- Be sure to include the instruction manual at transportation.

9.4 Product Information Display

The model name, firmware version, and other information about this product are displayed.

■ Operation procedure for checking from the system menu

1. Press the MENU key to move to the root menu, and then select [System]. The System menu opens.

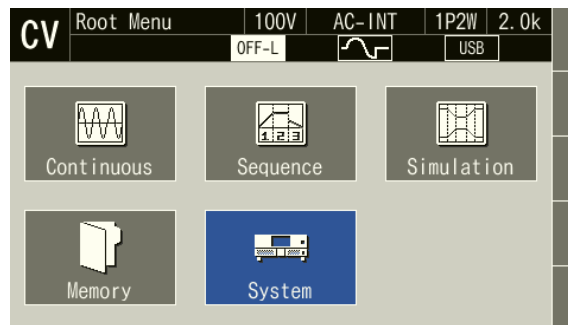

2. Put the cursor on [View] next to the [Information] item, then press the ENTER key.

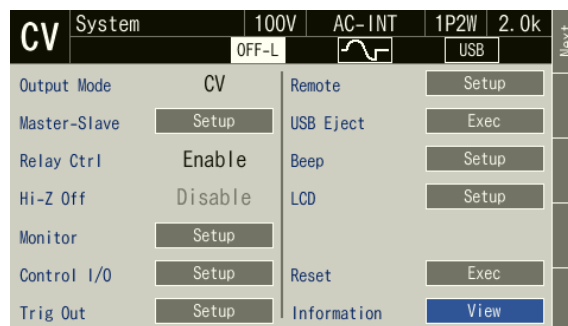

3. The Information window opens. The firmware version is shown at the [Version] item.

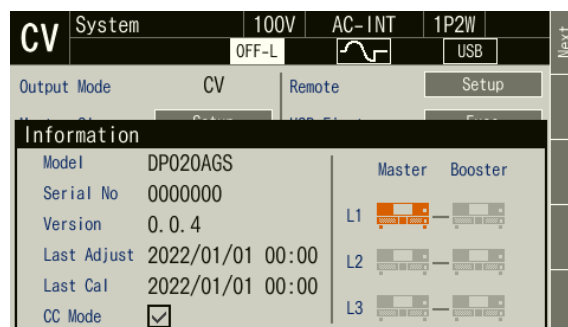

Note: This is a screenshot with firmware version 0.0.4.

■ Operation procedures by using shortcuts

SHIFT + **.** Open the information window

Press the SHIFT key to enter the shift state (the SHIFT LED illuminates). When you press the “.” key in the numeric keypad in the shift state, the information window opens.

■ 2D barcode

A 2D barcode is displayed on the second page of the System menu. The information in the 2D barcode consists of our company name, model name, manufacturing number, device information, firmware version, date last adjusted by NF Corporation, and date last calibrated by NF Corporation.

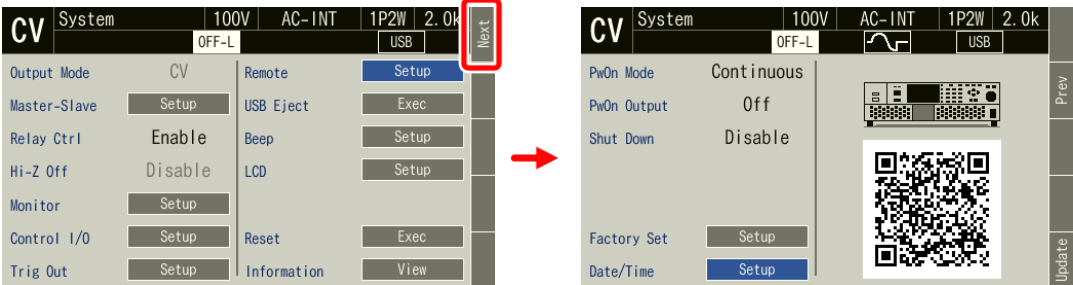

10. Specifications

10.1	Output Phase Configuration	214
10.2	Output Function.....	214
10.3	Output Mode.....	214
10.4	Output Range	214
10.5	AC/DC Mode	215
10.6	Signal Source	216
10.7	Constant Voltage Output	217
10.8	Constant Current Output (custom).....	220
10.9	Output Frequency	222
10.10	Output On and Off Phase, Phase Angle of Polyphase System	222
10.11	Soft Start and Soft Stop	223
10.12	Output Stability.....	223
10.13	Power Input.....	224
10.14	Withstand Voltage and Insulation Resistance	224
10.15	Measurement Function	225
10.16	Current Limiter (CV mode).....	228
10.17	Voltage Limiter (CC mode).....	229
10.18	Setting Range Limit Function	229
10.19	Remote Sensing	232
10.20	AGC.....	232
10.21	Autocal (Output Voltage Compensation)	233
10.22	Sequence	234
10.23	Simulation.....	235
10.24	Clipped Sine Wave.....	236
10.25	External Signal Input	237
10.26	General Function	239
10.27	Memory Function	240
10.28	Self-diagnosis/Protection Function	241
10.29	CONTROL I/O.....	242
10.30	External Interface	243
10.31	USB Memory Interface.....	244
10.32	Waveform Monitor Output.....	245
10.33	SHUT DOWN Input	245
10.34	Operation Environment	246
10.35	Externals, Mass, and Terminal Block.....	246
10.36	Option	247
10.37	Outline Dimensional Drawing	248

10. Specifications

Specifications are valid under the following settings and conditions and after a warm-up period of 30 minutes at least, unless otherwise noted.

Load: Resistive load, power factor = 1.

Signal source: INT (internal signal source).

Output voltage waveform: sine.

Remote sensing: off.

AGC/Autocal: off.

Limiter: factory default setting.

[set] indicates a setting value, [rdg] indicates a read value, [rng] indicates a maximum value, and [FS] indicates a full scale value.

The description noted with “/” indicates that the specification changes by the output range, such as “100 V (20 A) range specification / 200 V (10 A) range specification.”

A value with the accuracy is the guaranteed value of the specification. However, an accuracy noted as reference value shows the supplemental data for reference when the product is used, and is not under the guarantee. A value without the accuracy is the nominal value or representative value (shown as typ.).

■ Notes on multi-unit system (master-slave function)

		Description
System master		Master of entire system (master of L1 phase)
Slave	Phase master	L2 phase or L3 phase master operated by control signals from the system master
	Booster	Unit to expand the output capacity of the phase master

A polyphase system (single-phase three-wire system / three-phase four-wire system) can be configured by installing one or two phase masters on one system master. Boost-up (parallel output) of up to two units per phase is possible. The system can also be used as a single-phase two-wire system by setting all phases to the same phase. Therefore, systems from 2 kVA to a maximum of 18 kVA can be configured for single-phase two-wire output, from 4 kVA to a maximum of 12 kVA for single-phase three-wire output, and from 6 kVA to a maximum of 18 kVA for three-phase four-wire output.

The DP020AGS has system master and slave functions. *1

“1P2W” represents a single-phase two-wire, “1P3W” represents a single-phase three-wire, and “3P4W” represents a three-phase four-wire in this document unless otherwise noted.

When the master-slave function is enabled, the capacity and configuration are determined from the system cable connection at power-on.

Output Lo terminals connected together become a neutral point (N terminal) in both the 1P3W and 3P4W system. Hi terminals are called L1, L2, and L3, respectively (L3 exists only in 3P4W system). The phase master of L1 phase is the master of the entire system (called as system master), and other phase masters and boosters operate as slaves. Output voltage is defined with phase voltage (L1, L2, and L3 to N) in this document unless otherwise noted.

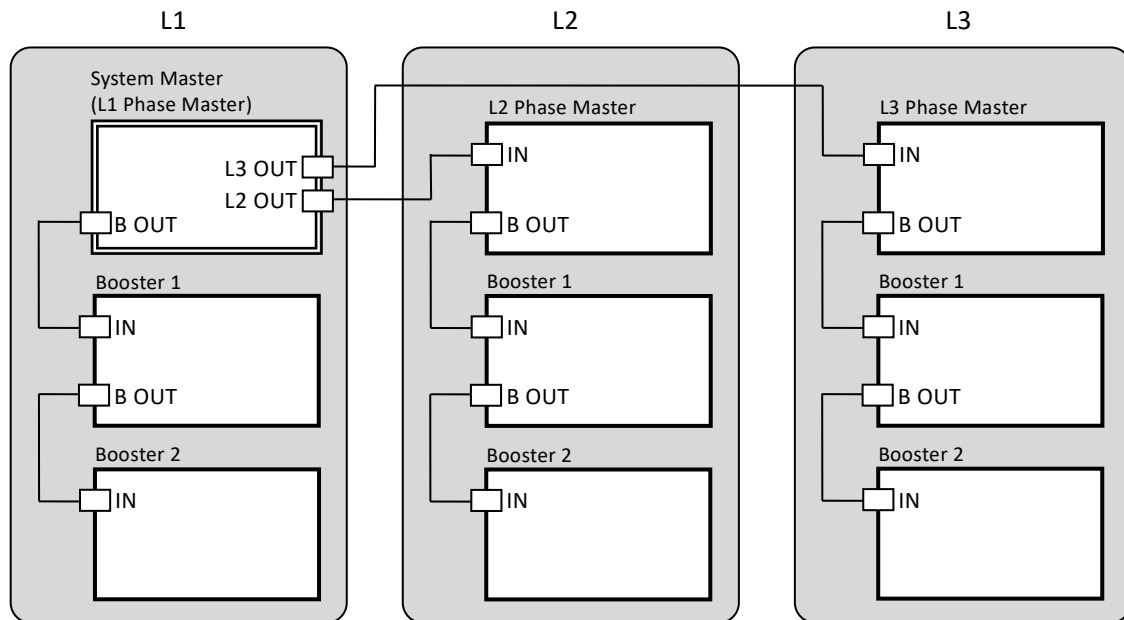

Figure 10-1 Maximum system configuration *1

*1: In the multi-unit system, if the number of boosters for each phase is different, an error occurs and output is not possible.

10.1 Output Phase Configuration

	Single-phase output	Polyphase output
Output phase Configuration	Single-unit, Single-phase two-wire system (= 1P2W system)	Polyphase system Single-phase three-wire system (= 1P3W system), (Y-connection) Three-phase four-wire system (= 3P4W system)

10.2 Output Function

	Single-unit	Multi-unit system
Output function	Continuous, Sequence, Simulation	

10.3 Output Mode

	Single-unit	Multi-unit system
Output mode	CV mode, CC mode (custom)	

10.4 Output Range

CV mode

	Single-unit	Multi-unit system
Output range	100 V range, 200 V range	

CC mode (custom)

	Single-unit	Multi-unit system
Output range	20 A range, 10 A range	

10.5 AC/DC Mode

CV mode

	Single-unit 1P2W system	Polyphase system	
		1P3W system	3P4W system
AC/DC mode	AC, ACDC, DC	AC, ACDC, DC	AC, ACDC

CC mode (custom)

	Single-unit 1P2W system	Polyphase system	
		1P3W system	3P4W system
AC/DC mode	AC, ACDC, DC	AC	

	Description
AC	<p>The signal source and amplification section of this product are AC-coupled, and the DC component is canceled.</p> <p>Only the AC output setting of 40 Hz to 550 Hz is available.</p> <p>The signal sources that can be combined are INT, VCA and SYNC.</p>
ACDC	<p>The signal source and amplification section of this product are DC-coupled, and the DC component is also amplified.</p> <p>The AC and DC output settings of 1 Hz to 550 Hz are available.</p> <p>The signal sources that can be combined are INT and SYNC.</p> <p>In a 3P4W system in CV mode, only the AC output setting is available.</p> <p>Fixed to this mode in the Simulation.</p> <p>Select this mode when you want to amplify a signal including DC, to superimpose DC (DC offset), or output a frequency of 40 Hz or lower. Also select this mode when the DC component temporally occurs, for example, by sudden change of voltage or phase.</p>
DC	<p>The signal source and amplification section of this product are DC-coupled.</p> <p>Only the DC setting is available.</p> <p>The signal sources that can be combined are INT and VCA.</p> <p>For other than 1P2W, the setting is possible only for 1P3W in CV mode.</p>

10.6 Signal Source

	Single-unit 1P2W system	Polyphase system (1P3W system, 3P4W system)
Signal source	INT, VCA, SYNC	INT, VCA, SYNC

	Description
INT	<p>Uses the internal signal source.</p> <p>Sets the output voltage or output current, output waveform, frequency, output on phase, and output off phase by using the panel or the external interface such as USB.</p> <p>Fixed to INT in the Sequence and Simulation.</p>
VCA	<p>Uses the internal signal source.</p> <p>Controls the output voltage or output current setting of the internal signal source with the DC signal which is input to the external input terminal. The output voltage setting cannot be set from external interfaces such as the panel or USB. All conditions except for output voltage setting are same as INT.</p> <p>In the 1P3W system and 3P4W system, the setting is common to all the phases.</p> <p>Cannot be selected in the ACDC.</p>
SYNC	<p>Uses the internal signal source.</p> <p>Synchronizes the frequency of the internal signal source with the signal (EXT) from the external synchronization signal input terminal (also used as the external input terminal) or the power supply input frequency (LINE) of the product. The frequency setting cannot be set from external interfaces such as the panel or USB. All conditions except for output frequency setting are same as INT.</p> <p>Cannot be selected in the DC.</p>

10.7 Constant Voltage Output

10.7.1 AC Voltage Output (CV mode)

[V]=Vrms, [A]=Arms, unless otherwise noted.

		Single-unit	Multi-unit system
Output phase configuration		1P2W Floating output, the Lo terminal can be grounded.	1P2W, 1P3W, 3P4W Floating output, the Neutral point (Lo terminal) can be grounded.
Setting mode *2		–	Balanced mode, Unbalanced mode
Rated output voltage		100 V / 200 V	
Voltage setting range *3	Range 1	0.0 V to 175.0 V / 0.0 V to 350.0 V (AC)	
	Range 2	0.0 V to 160.0 V / 0.0 V to 320.0 V (ACDC)	
Setting resolution		0.1 V	
Voltage accuracy *4		$\pm (0.3 \% \text{ of set} + 0.3 \text{ V} / 0.6 \text{ V})$	
Line voltage setting range *5	Range 1	–	(AC) 1P3W 0.0 V to 350.0 V / 0.0 V to 700.0 V 3P4W 0.0 V to 303.0 V / 0.0 V to 606.0 V
	Range 2	–	(ACDC) 1P3W 0.0 V to 320.0 V / 0.0 V to 640.0 V 3P4W 0.0 V to 277.2 V / 0.0 V to 554.2 V
Setting resolution		–	0.2 V
Maximum current *6 *7		20 A / 10 A	1P2W 20 A \times N / 10 A \times N 1P3W, 3P4W 20 A \times (1 + B) / 10 A \times (1 + B)
Maximum peak current *8		Peak value (Apk) which is 4 times of the maximum current	Peak value (Apk) which is 3.5 times of the maximum current
Power capacity *7		2 kVA	1P2W 2 kVA \times N 1P3W 4 kVA \times (1 + B) 3P4W 6 kVA \times (1 + B)
Load power factor		0 to 1 (Phase lead or phase lag, 45 Hz to 65 Hz, external power injection or regeneration are not available.)	
Voltage frequency characteristic *9		45 Hz to 65 Hz : within $\pm 0.3 \%$ 40 Hz to 550 Hz : within $\pm 0.5 \%$	
Distortion *10		40 Hz to 550 Hz : 0.3 % or less	
Output waveform		sine wave, clipped sine wave (3 types)	
DC offset *11		Within ± 20 mV (typ., fine adjustment available.)	

*2: Only when the 1P3W system and the 3P4W system is configured, can be set.

*3: In the 1P3W system and the 3P4W system, this specification is for the phase voltage settings. In balanced mode, all phases are set together. In unbalanced mode, each phase is set individually.
For DC voltage setting in the 1P3W system and ACDC, see *12.

10. Specifications

- *4: In the case of 10 V to 175 V / 20 V to 350 V, sine wave, no load, 45 Hz to 65 Hz, DC voltage setting 0 V, 23 °C±5 °C.
In the 1P3W system and the 3P4W system, this specification is the accuracy for the phase voltage settings of the system master or phase master.
- *5: Only when the 1P3W system and the 3P4W system is configured and when balanced mode and sine wave are set, line voltage setting can be set.
- *6: If the output voltage is higher than the rated value, this is limited (lowered) to satisfy the power capacity. If there is the DC superimposition, the RMS current of AC+DC satisfies the maximum current. In the case of 40 Hz or lower, and that the ambient temperature is 40 °C or higher, the maximum current may decrease.
- *7: “N” represents the number of units configured for the entire system, and “B” represents the number of boost-up units for each phase. The range of “N” is from 2 to 9 units, and the range of “B” is from 0 to 2 units. See *Figure 10-1*.
- *8: For the capacitor input type rectified load, the rated output voltage, and 45 Hz to 65 Hz.
- *9: For sine wave, the rated output voltage, the resistance load for the maximum current, and 55 Hz reference.
- *10: 80 % or higher of the rated output voltage, the maximum current or lower, AC and ACDC, THD. In the 1P3W system and the 3P4W system, this specification is the value for the phase voltage.
- *11: In the case of the AC and 23 °C±5 °C.

10.7.2 DC Voltage Output (CV mode)

[V]=Vdc, [A]=Adc, unless otherwise noted. The polarity is relative to the Lo terminal.

	Single-unit	Multi-unit system
Output phase configuration	1P2W Floating output, the Lo terminal can be grounded.	1P2W, 1P3W Floating output, the neutral point (Lo terminal) can be grounded.
Rated output voltage	100 V / 200 V	
Voltage setting range *12	-227.0 V to +227.0 V / -454.0 V to +454.0 V	
Setting resolution	0.1 V	
Voltage accuracy *13	± (0.05 % of set + 0.1 V / 0.2 V)	
Maximum current *14 *15	20 A / 10 A	1P2W 20 A × N / 10 A × N 1P3W, 20 A × (1 + B) / 10 A × (1 + B)
Maximum instantaneous source current *16	Peak value (A _{pk}) which is 4 times of the maximum source current	Peak value (A _{pk}) which is 3.5 times of the maximum source current
Power capacity *15	2 kW	1P2W 2 kW × N 1P3W 4 kW × (1 + B)

- *12: In the 1P3W system, the voltage setting is for the L1 phase. The L2 phase outputs the same set voltage of opposite polarity with respect to the L1 phase with reference to the Lo terminal. For example, if the voltage setting is set to +100 V, the output voltage is +100 V between the Hi-Lo terminals of L1 phase and -100 V between the Hi-Lo terminals of L2 phase. The line voltage between the Hi terminals of L1 and L2 is +200 V with reference to the Hi terminal of the L2 phase.
- *13: In the case of -227 V to -10 V, +10 V to +227 V / -454 V to -20 V, +20 V to +454 V, no load, AC setting 0 V, and 23 °C±5 °C.
- *14: If the output voltage is higher than the rated value, this is limited (lowered) to satisfy the power capacity. If there is the AC superimposition, the RMS current of DC+AC satisfies the maximum current. In the case that the ambient temperature is 40 °C or higher, the maximum source current may decrease.
- *15: “N” represents the number of units configured for the entire system, and “B” represents the number of boost-up units for each phase. The range of “N” is from 2 to 9 units, and the range of “B” is from 0 to 2 units. See *Figure 10-1*.
- *16: Instantaneous = within 2 ms, at the rated output voltage.

10.8 Constant Current Output (custom)

10.8.1 AC Current Output (CC mode)

[V]=Vrms, [A]=Arms, unless otherwise noted.

	Single-unit	Multi-unit system *17
Output phase configuration	1P2W Floating output, the Lo terminal can be grounded.	1P2W, 1P3W, 3P4W Floating output. Connect neutral point (Lo terminal) to load.
Setting mode *18	–	Balanced mode, Unbalanced mode
Maximum current *19 *20	20 A / 10 A	1P2W 20 A × N / 10 A × N 1P3W, 3P4W 20 A × (1 + B) / 10 A × (1 + B)
Current setting range *20 *21 *22	0.00 A to 20.00 A / 0.00 A to 10.00 A	1P2W 0 A to 20 A × N / 0 A to 10 A × N 1P3W, 3P4W 0 A to 20 A × (1 + B) / 0A to 10 A × (1 + B)
Setting resolution	0.01 A (set < 100 A), 0.1 A (set < 1000 A), 1 A (set ≥ 1000 A)	
Current accuracy *23	± (0.6 % of set + 0.5 % of rng)	
Rated output voltage	100 V / 200 V	
Maximum output voltage *19	227 V / 454 V	
Power capacity *20	2 kVA	1P2W 2 kVA × N 1P3W 4 kVA × (1 + B) 3P4W 6 kVA × (1 + B)
Load power factor	0 to 1 (Phase lead or phase lag, 45 Hz to 65 Hz, external power injection or regeneration are not available.)	
Voltage frequency characteristic *24	45 Hz to 65 Hz : within ±0.4 % 40 Hz to 99.9 Hz : within ±0.6 % 100 Hz to 550 Hz : within ± (6.0 × fo) % “fo” is output frequency [kHz].	
Distortion *25	40 Hz to 550 Hz : 0.6 % or less	
Output waveform	sine wave	
DC offset *20 *26 (typ., fine adjustment available.)	Within ±50 mA	1P2W Within ±50 mA × N 1P3W, 3P4W Within ±50 mA × (1 + B)

*17: Connect neutral point (Lo terminal) of the 1P3W system and the 3P4W system to load. If the neutral point (Lo terminal) is not connected to the load, this product will not output properly. The neutral point (Lo terminal) can be grounded.

*18: Only when the 1P3W system and the 3P4W system is configured, can be set.

- *19: The peak voltage of AC+DC satisfies the maximum output voltage. If the output voltage is higher than the rated value, this is limited (lowered) to satisfy the power capacity. In the case of 40 Hz or lower, and that the ambient temperature is 40 °C or higher, the rated output voltage may decrease. The voltage slew rate should be 3 V/μs or less; continuous operation at 3 V/μs or more may cause failure.
- *20: “N” represents the number of units configured for the entire system, and “B” represents the number of boost-up units for each phase. The range of “N” is from 2 to 9 units, and the range of “B” is from 0 to 2 units. See *Figure 10-1*.
When a multi-unit system of “N” or “(1+B)” units is configured, the output resolution is “N” or “(1+B)” times the setting resolution.
- *21: In the 1P3W system and the 3P4W system, this specification is for the phase current settings. In balanced mode, all phases are set together. In unbalanced mode, each phase is set individually.
- *22: If the RMS current of AC+DC is higher than the maximum current, the output current is limited (lowered) to satisfy the maximum current.
The peak value setting of 4 (single-unit) or 3.5 (multi-unit system) times the maximum current should be used under the following conditions. Instantaneous (within 2 ms), within rated output voltage, 45 Hz to 65 Hz.
- *23: In the case of 5 % to 100 % of maximum current, sine wave, no load, 45 Hz to 65 Hz, DC current setting 0 A, 23 °C±5 °C. In the 1P3W system and the 3P4W system, this specification is the accuracy for the phase current.
- *24: For sine wave, the maximum current, the resistance load for the rated output voltage, and 55 Hz reference.
- *25: 50 % or higher of the maximum current, the rated output voltage or lower (resistance load), AC and ACDC, THD. In the 1P3W system and the 3P4W system, this specification is the value for the phase current.
- *26: In the case of the AC and 23 °C±5 °C.

10.8.2 DC Current Output (CC mode)

[V]=Vdc, [A]=Adc, unless otherwise noted. The polarity is relative to the Lo terminal.

	Single-unit	1P2W system
Output phase configuration	1P2W Floating output, the Lo terminal can be grounded.	
Maximum current *27 *28	20 A / 10 A	20 A × N / 10 A × N
Current setting range *28	-20.00 A to +20.00 A / -10.00 A to +10.00 A	-20 A × N to +20 A × N / -10 A × N to +10 A × N
Setting resolution	0.01 A (set < 100 A), 0.1 A (set < 1000 A)	
Current accuracy *29	± (0.2 % of set + 0.5 % of rng)	
Rated output voltage	100 V / 200 V	
Maximum voltage *27	227 V / 454 V	
Power capacity *28	2 kW	2 kW × N

- *27: If the output voltage is higher than the rated value, this is limited (lowered) to satisfy the power capacity. If there is the AC superimposition, the RMS voltage of DC+AC satisfies the rated output voltage. In the case that the ambient temperature is 40 °C or higher, the rated output voltage may decrease.
- *28: “N” represents the number of units configured for the entire system. The range of “N” is from 2 to 9 units. See *Figure 10-1*. When a 1P2W system of “N” units is configured, the output resolution is “N” times the setting resolution.
- *29: In the case of 5 % to 100 % of maximum current, no load, AC current setting 0 A, 23 °C±5 °C.

10.9 Output Frequency

	Single-unit	Multi-unit system
Frequency setting range	40.00 Hz to 550 Hz (AC) 1.00 Hz to 550 Hz (ACDC)	
Setting resolution	0.01 Hz (set < 100 Hz) 0.1 Hz (set < 550 Hz)	
Frequency accuracy	±0.01 % of set (23 °C±5 °C)	
Frequency stability *30	±0.005 %	

*30: In the case of CV mode, this is the specification at rated output voltage, no load, and the resistance load for the maximum current. In the case of CC mode, this is the specification at maximum current, no load or resistance load for the rated output voltage. Furthermore, in both cases this is a specification for the 45 Hz to 65 Hz, operating temperature.

10.10 Output On and Off Phase, Phase Angle of Polyphase System

	Single-unit 1P2W system	Polyphase system (1P3W system, 3P4W system)
Output on phase setting range *31 *32	0.0° to 359.9° variable	
Setting resolution	0.1°	
Output off phase setting range *31 *33	0.0° to 359.9° variable (Enable / Disable selectable)	
Setting resolution	0.1°	
Phase angle setting range	—	1P3W L1 phase: 0.0° to 359.9° L2 phase: 0.0° to 359.9° 3P4W L1 phase: 0.0° to 359.9° L2 phase: 0.0° to 359.9° L3 phase: 0.0° to 359.9°
Setting resolution	0.1°	
Phase angle accuracy *34	—	45 Hz to 65 Hz: ±0.5° 65 Hz to 550 Hz: ±(0.44 + 0.9 × fo) ° “fo” is output frequency [kHz].

- *31: In the 1P3W system and the 3P4W system, these settings are for the L1 phase.
- *32: It cannot be set to a value other than 0.0° if soft start is set to Enable.
- *33: It cannot be selected Enable if soft stop is set to Enable.

*34: Output waveform is sine wave, the load conditions for all phases are the same, the voltage or current settings for all phases are the same.

In the case of CV mode, the specification is for output voltages of 50 V or more.

In the case of CC mode, the specification is for output current of 5 A or more.

10.11 Soft Start and Soft Stop

	Single-unit	Multi-unit system
Soft start *35 *36	Setting time: 0 s to 30 s (Enable / Disable selectable) Enable: Gradual increase in output when output is switched on.	
Soft stop *35 *37	Setting time: 0 s to 30 s (Enable / Disable selectable) Enable: Gradual decrease in output when output is switched off.	

*35: When VCA is selected as signal source, or when AGC or Autocal setting is on, or when high impedance output off function setting is enabled, these settings cannot be selected Enable.

*36: It cannot be selected Enable, when the set value of the output on phase is set to a value other than 0.0°.

*37: It cannot be selected Enable, when the output off phase setting is Enable.

10.12 Output Stability

	Single-unit	Multi-unit system
Fluctuation with input voltage *38	Within ± 0.1 % (typ.)	
Fluctuation with output current (CV mode) *39	DC, 10 Hz to 100 Hz Within ± 0.1 V / ± 0.2 V 100.1 Hz to 550 Hz Within ± 0.3 V / ± 0.6 V	
Fluctuation with output voltage (CC mode) *40	DC, 40 Hz to 100 Hz Within ± 0.2 % of rng 100.1 Hz to 550 Hz Within $\pm (9.5 \times f_o)$ % of rng “fo” is output frequency [kHz].	
Fluctuation with ambient temperature *41	Within ± 0.01 %/°C (typ.)	

*38: For power input 90 V to 250 V, power input 200 V reference, and for the resistance load at the maximum current, the rated output voltage, DC or 45 Hz to 65 Hz. Transition state immediately after a change of the input power-supply voltage is not included. In the 1P3W system and the 3P4W system, this specification is the value for the phase voltage or phase current.

10. Specifications

- *39: In the case that the output current is changed from 0 % to 100 % of the maximum current. For output voltage 50 V to 160 V/100 V to 320 V, no load reference. However, if the output voltage is higher than the rated value, the maximum current is limited to satisfy the power capacity. When the output frequency is between 10 and 40 Hz, the peak output current is within the maximum current. In the 1P3W system and the 3P4W system, this specification is the value for the phase voltage.
- *40: In the case that the output voltage is changed from 0 % to 100 % of the rated output voltage. For output current 10 A to 20 A/5 A to 10 A, no load reference. However, if the output voltage is higher than the rated value, the output current is limited to satisfy the power capacity. In the 1P3W system and the 3P4W system, this specification is the value for the phase current.
- *41: For power input 200 V, DC or 45 Hz to 65 Hz. In the case of CV mode, for no load and rated output voltage. In the case of CC mode, for no load and maximum current. In the 1P3W system and the 3P4W system, this specification is the value for the phase voltage or phase current.

10.13 Power Input

	Single-unit
Voltage	100 V to 230 V ± 10 %, with limited to 250 V or lower, Overvoltage Category II
Frequency	50 Hz ± 2 Hz or 60 Hz ± 2 Hz
Phase	Single-phase
Power factor *42	0.95 or higher (typ.)
Efficiency *42	80 % or higher (typ.)
Maximum power consumption	2.65 kVA or lower

- *42: In the case of AC- INT, the rated output voltage, the resistance load at the maximum current, 45 Hz to 65 Hz output.

10.14 Withstand Voltage and Insulation Resistance

Power input - Output/Chassis and Power input/Chassis - Output

	Single-unit
Withstand voltage	AC 1500 V or DC 2130 V, 1 minute.
Insulation resistance	30 M Ω or higher (DC 500 V)

10.15 Measurement Function

All accuracy of the measurement function is indicated for 23 °C±5 °C.

Voltage *43

		Single-unit	Multi-unit system
Effective value (rms)	Full scale	250.0 V / 500.0 V	
	Resolution	0.1 V	
	Accuracy	DC, 40 Hz to 550 Hz ± (0.3 % of rdg + 0.5 V / 1.0 V)	
DC average value (avg)	Full scale	±250.0 V / ±500.0 V	
	Resolution	0.1 V	
	Accuracy	DC ± (0.3 % of rdg + 0.5 V / 1.0 V)	
Peak value (pk) (each of max and min)	Full scale	±250.0 V / ±500.0 V	
	Resolution	0.1 V	
	Accuracy *44	DC, 45 Hz to 65 Hz ± (2 % of rdg + 1 V / 2 V)	

*43: The accuracy values are in the case that the output voltage is within voltage setting range. In the 1P3W system and the 3P4W system, this specification is for the phase voltage. The output voltage of the system master or phase master is measured.

*44: The accuracy of the peak value is for a waveform of DC or sine wave.

Line voltage (Only with CV mode and sine waveform output.)

		Polyphase system (1P3W system, 3P4W system)	
Effective value (rms) *45	Full scale	1P3W: 500.0 V / 1000.0 V 3P4W: 433.0 V / 866.0 V	
	Resolution	0.1 V	
DC average value (avg) *46	Full scale	1P3W: 500.0 V / 1000.0 V	
	Resolution	0.1 V	

*45: The displayed value is the result of calculation with the phase voltage measured value and the phase angle setting value regarding the output voltage waveform as a sine wave.

*46: The displayed value is the result of calculation with the phase voltage measured value.

10. Specifications

Current *47 *48

		Single-unit	Multi-unit system
Effective value (rms)	Full scale *49	24 A / 12 A	1P2W 24 A × N / 12 A × N 1P3W, 3P4W 24 A × (1 + B) / 12 A × (1 + B)
	Resolution	0.01 A (rdg < 100 A), 0.1 A (rdg < 1000 A)	
	Accuracy	DC, 45 Hz to 65 Hz: ± (0.3 % of rdg + 0.3 % of FS) 40 Hz to 550 Hz: ± (0.6 % of rdg + 0.6 % of FS)	
DC average value (avg)	Full scale *49	±24 A / ±12 A	1P2W ±24 A × N / ±12 A × N 1P3W ±24 A × (1 + B) / ±12 A × (1 + B)
	Resolution	0.01 A (rdg < 100 A), 0.1 A (rdg < 1000 A)	
	Accuracy	DC: ± (0.3 % of rdg + 0.3 % of FS)	
Peak value (pk) (each of max and min)	Full scale *49	±96 A / ±48 A	1P2W ±96 A × N / ±24 A × N 1P3W ±96 A × (1 + B) / ±48 A × (1 + B)
	Resolution	0.01 A (rdg < 100 A), 0.1 A (rdg < 1000 A)	
	Accuracy (Reference Value) *50	DC, 45 Hz to 65 Hz: ± (2 % of rdg + 0.3 % of FS)	
	Hold	Holds the maximum values of max and min with the polarity (with the clear function)	

*47: The accuracy values are in the case that the output current is 5 % to 100 % of the maximum current.

*48: In the 1P3W system and the 3P4W system these are the specifications for the phase current. In the 3P4W system the DC average value display cannot be selected.

*49: “N” represents the number of units configured for the entire system, and “B” represents the number of boost-up units for each phase. The range of “N” is from 2 to 9 units, and the range of “B” is from 0 to 2 units. See *Figure 10-1*.

*50: The accuracy of the peak value is for a waveform of DC or sine wave.

Power *51 *52 *53

		Single-unit	Multi-unit system
Active (W)	Full scale *54	±2.4 kW	±2.4 kW × N
	Resolution	1 W	
	Accuracy *55	45 Hz to 65 Hz: ± (0.3 % of rdg + 0.3 % of FS)	
Apparent (VA) *56	Full scale *54	3.0 kVA	3.0 kW × N
	Resolution	1 VA	

*51: All in the case of sine wave, 50 V or higher output voltage, and that the output current is 10 % or higher of the maximum current. In the 1P3W system and the 3P4W system, power is measured from the output voltage of the system master or phase master.

*52: In the 1P3W system and the 3P4W system, the all-phase total power display is available.

*53: The apparent powers are not displayed in the DC.

- *54: “N” represents the number of units configured for the entire system. The range of “N” is from 2 to 9 units. See *Figure 10-1*.
- *55: The accuracy of the active power is for the load with the power factor 0.5 or higher. In the 1P3W system and the 3P4W system, the accuracy is for each phase.
- *56: The accuracy of apparent power is a composite of the accuracy of voltage and current.

Load power factor, Load crest factor

		Single-unit	Multi-unit system
Power factor *57	Measurement range	-1.00 to +1.00	
	Resolution	0.01	
Crest factor	Measurement range	0.00 to 50.00	
	Resolution	0.01	

*57: The power factor is not displayed in the DC.

Synchronization frequency (only SYNC)

	Single-unit	Multi-unit system
Display range	38.0 Hz to 550.0 Hz	
Resolution	0.1 Hz	
Accuracy	40 Hz to 550 Hz: ± 0.2 Hz	

Harmonic analysis (AC-INT, phase current or phase voltage) *58

		Single-unit	Multi-unit system
Measurement object		Output current, Output voltage, Sensing output voltage	
Measurement item		Effective value, Percentage of the effective value relative to the fundamental.	
Frequency range (fundamental wave)		40 Hz to 550 Hz	
Measurement range *59		Up to 1st to 50th order of the fundamental wave.	
Full scale	Current *60	24 A / 12 A	1P2W 24 A \times N / 12 A \times N 1P3W, 3P4W 24 A \times (1 + B) / 12 A \times (1 + B)
	Voltage	250.0 V / 500.0 V	
Resolution	Current	0.01 A (rdg < 100 A), 0.1 A (rdg < 1000 A)	
	Voltage	0.1 V	
	Percentage	0.1 %	

- *58: The measurement does not conform to the IEC or other standard.
- *59: The maximum frequency that can be analyzed is 5000 Hz. The upper limit of the analysis order depends on the frequency of the fundamental wave.
- *60: “N” represents the number of units configured for the entire system, and “B” represents the number of boost-up units for each phase. The range of “N” is from 2 to 9 units, and the range of “B” is from 0 to 2 units. See *Figure 10-1*.

10.16 Current Limiter (CV mode)

This controls the output voltage for the output current to be within the limiter setting value when the peak value or RMS exceeds it. The output can be configured to be turned off when the limited state continues over the specified time.

In the 1P3W system and the 3P4W system, the settings are made for the phase current and common to all the phases.

If a configuration change is made that changes the setting range, the limiter setpoint is reset to the largest absolute value.

Peak current limiter

		Single-unit	Multi-unit system
Positive current	Setting Range (Peak value) *61	+10.0 A to +84.0 A / +5.0 A to +42.0 A	1P2W +10.0 A × N to +84.0 A × N / +5.0 A × N to +42.0 A × N 1P3W, 3P4W +10.0 A × (1+B) to +84.0 A × (1+B) / +5.0 A × (1+B) to +42.0 A × (1+B)
	Factory default	+84.0 A / +42.0 A	—
Negative current	Setting Range (Peak value) *61	-84.0 A to -10.0 A / -42.0 A to -5.0 A	1P2W -84.0 A × N to -10.0 A × N / -42.0 A × N to -5.0 A × N 1P3W, 3P4W -84.0 A × (1+B) to -10.0 A × (1+B) / -42.0 A × (1+B) to -5.0 A × (1+B)
	Factory default	-84.0 A / -42.0 A	—
Resolution		0.1 A (set < 100 A), 1 A (set < 1000 A)	
Limiter operation		Select whether to recover automatically (continuous) or turn the output off when the limited state continues over the specified time (1 s to 10 s, resolution 1 s). Factory default setting is output OFF when the limit state continues for 10 s.	

RMS current limiter

		Single-unit	Multi-unit system
Setting range (effective value) *61		1.0 A to 21.0 A / 1.0 A to 10.5 A	1P2W 1.0 A × N to 21.0 A × N / 1.0 A × N to 10.5 A × N 1P3W, 3P4W 1.0 A × (1+B) to 21.0 A × (1+B) / 1.0 A × (1+B) to 10.5 A × (1+B)
	Factory default	21.0 A / 10.5 A	—
Resolution		0.1 A (set < 100 A), 1 A (set < 1000 A)	
Limiter operation		Select whether to recover automatically (continuous) or turn the output off when the limited state continues over the specified time (1 s to 10 s, resolution 1 s). Factory default setting is output OFF when the limit state continues for 10 s.	

*61: “N” represents the number of units configured for the entire system, and “B” represents the number of boost-up units for each phase. The range of “N” is from 2 to 9 units, and the range of “B” is from 0 to 2 units. See *Figure 10-1*.

When a multi-unit system of “N” or “(1+B)” units is configured, the output resolution is “N” or “(1+B)” times the setting resolution.

10.17 Voltage Limiter (CC mode)

This controls the output current for the output voltage to be within the limiter setting value when the peak value or RMS exceeds it. The output can be configured to be turned off when the limited state continues over the specified time.

In the 1P3W system and the 3P4W system, the settings are made for the phase voltage and common to all the phases.

Peak voltage limiter

		Single-unit	Multi-unit system
Positive current	Setting Range (Peak value)	+50 V to +238 V / +100 V to +476 V	
	Factory default	+238 V / +476 V	
Negative current	Setting Range (Peak value)	-238 V to -50 V / -476 V to -100 V	
	Factory default	-238 V / -476 V	
Resolution		1 V	
Limiter operation		Select whether to recover automatically (continuous) or turn the output off when the limited state continues over the specified time (1 s to 10 s, resolution 1 s). Factory default setting is output OFF when the limit state continues for 10 s.	

RMS voltage limiter

		Single-unit	Multi-unit system
Setting range (effective value)		10 V to 227 V / 10 V to 454 V	
Factory default		227 V / 454 V	
Resolution		1 V	
Limiter operation		Select whether to recover automatically (continuous) or turn the output off when the limited state continues over the specified time (1 s to 10 s, resolution 1 s). Factory default setting is output OFF when the limit state continues for 10 s.	

10.18 Setting Range Limit Function

This is the limit function for the setting of the internal signal source. It works when the signal source is INT, VCA (frequency setting limit only), SYNC (voltage setting limit only).

The limitation does not work for the Sequence and Simulation.

In the 1P3W system and the 3P4W system, the setting is common to all the phases.

10.18.1 Voltage Setting Limit Function (CV mode)

Output voltage setting limit function in CV mode.

Voltage setting limit 1

(in the AC, and sine wave or clipped sine wave is selected)

	Single-unit 1P2W system	Polyphase system (1P3W system, 3P4W system)
Phase voltage setting range (effective value)	0.1 V to 175.0 V / 0.1 V to 350.0 V	
Line voltage setting range (effective value) *62	–	1P3W 0.2 V to 350.0 V / 0.2 V to 700.0 V 3P4W 0.2 V to 303.0 V / 0.2 V to 606.0 V
Factory default	Phase voltage setting, 175.0 V / 350.0 V	
Resolution	Phase voltage setting: 0.1 V	
	–	Line voltage setting: 0.2 V

*62: The line voltage setting is available only when the output voltage setting is set as the line voltage and sine wave is selected in the balanced mode of the polyphase system.

Voltage setting limit 2 (other than Voltage setting limit 1, phase voltage setting only) *63

		Single-unit	Multi-unit system
Positive voltage	Setting Range (Peak value)	+0.1 V to +227.0 V / +0.1 V to +454.0 V	
	Factory default	+227.0 V / +454.0 V	
Negative voltage	Setting Range (Peak value)	–227.0 V to –0.1 V / –454.0 V to –0.1 V	
	Factory default	–227.0 V / –454.0 V	
Resolution		0.1 V	

*63: The limitation is applied to the additional values of the AC voltage setting (recalculated to a peak value) and the DC voltage setting.

10.18.2 Current Setting Limit Function (CC mode)

Current setting limit 1 (in the AC, and sine wave is selected)

		Single-unit	Multi-unit system
Current setting range (effective value) *64		0.01 A to 20.00 A / 0.01 A to 10.00 A	1P2W 0.01 A to 20 A × N / 0.01 A to 10 A × N 1P3W, 3P4W 0.01 A to 20 A × (1+B) / 0.01 A to 10 A × (1+B)
Factory default		20.00 A / 10.00 A	–
Resolution		0.01 A (set < 100 A), 0.1 A (set < 1000 A)	

Current setting limit 2 (in the ACDC, and sine wave is selected)

	Single-unit	1P2W system
Current setting range (effective value) *64	0.01 A to 20.00 A / 0.01 A to 10.00 A	0.01 A to 20 A × N / 0.01 A to 10 A × N
Factory default	20.00 A / 10.00 A	–
Resolution	0.01 A (set < 100 A), 0.1 A (set < 1000 A)	

Current setting limit 3 (other than Current setting limit 1 and 2, phase current setting only) *65

		Single-unit	Multi-unit system
Positive current	Setting Range (Peak value) *64	+0.01 A to +80.00 A / +0.01 A to +40.00 A	1P2W +0.01 A × N to +80 A × N / +0.01 A × N to +40 A × N 1P3W, 3P4W +0.01 A × to +80 A × (1+B) / +0.01 A × to +40 A × (1+B)
	Factory default	+80.00 A / +40.00 A	–
Negative current	Setting Range (Peak value) *64	–80.00 A to –0.01 A / –40.00 A to –0.01 A	1P2W –80 A × N to –0.01 A × N / –40 A × N to –0.01 A × N 1P3W, 3P4W –80 A × to –0.01 A × (1+B) / –40 A × to –0.01 A × (1+B)
	Factory default	–80.00 A / –40.00 A	–
Resolution		0.01 A (set < 100 A), 0.1 A (set < 1000 A)	

*64: “N” represents the number of units configured for the entire system, and “B” represents the number of boost-up units for each phase. The range of “N” is from 2 to 9 units, and the range of “B” is from 0 to 2 units. See *Figure 10-1*.

When a multi-unit system of “N” or “(1+B)” units is configured, the output resolution is “N” or “(1+B)” times the setting resolution.

*65: The limitation is applied to the additional values of the AC current setting (recalculated to a peak value) and the DC current setting.

10.18.3 Frequency Setting Limit Function

Frequency setting limit (the lower limit ≤ the upper limit)

		Single-unit	Multi-unit system
Upper limit	Setting Range	40.00 Hz to 550 Hz (AC) 1.00 Hz to 550 Hz (ACDC)	
	Factory default	550 Hz (AC, ACDC)	
Lower limit	Setting Range	40.00 Hz to 550 Hz (AC) 1.00 Hz to 550 Hz (ACDC)	
	Factory default	40 Hz (AC) 1 Hz (ACDC)	
Resolution		0.01 Hz (set < 100 Hz), 0.1 Hz (set ≤ 550 Hz)	

10.19 Remote Sensing

This switches the voltage used for measurement. When the remote sensing is on, the V sensing terminal voltage is used. When it is off, the output terminal voltage is used.

By combining with AGC or Autocal, a voltage drop due to wiring to the load can be compensated. When the remote sensing is on, the output voltage detection point corrected by the AGC or Autocal function is switched to the V sensing terminal. When AGC or Autocal is off, only the detection voltage used for measurement display is switched.

Effective only for AC-INT, AC-VCA, AC-SYNC, DC-INT, and DC-VCA and when the waveform is sine wave or DC.

It is turned off when the Sequence or Simulation is selected. However, in case the stand-by state of sequence mode (step 0) effective only for AC-INT, ACDC-INT and DC-INT and when the waveform is sine wave or DC. Remote sensing cannot be activated unless either AC voltage or DC voltage setting is 0 V for ACDC-INT. Also, remote sensing is turned off once when you change AC/DC mode.

It cannot be set to on in CC mode.

	Measurement voltage, power, power factor	AGC/Autocal	
		Off	On
On	Use the V sensing terminal voltage	Not active	Active
Off	Use the output terminal voltage	Not active (factory default)	Active

10.20 AGC

When the AGC (Automatic Gain Control) is on, the detection point voltage is always measured, and the output voltage is continuously corrected so that its effective value is equal to the output voltage setting value. The fluctuation of the detection point voltage can be suppressed even when the load is fluctuated. The detection point can be switched between the V sensing terminal (remote sensing on) and the output terminal (remote sensing off).

Effective only for AC-INT, AC-VCA, AC-SYNC, DC-INT, and DC-VCA and when the waveform is sine wave or DC. It is turned off when the Sequence or Simulation is selected. It cannot be selected when the Autocal is set to on.

It cannot be set to on in CC mode.

	Single-unit	Multi-unit system
Response time	Within 100 ms (typ.) (DC/50 Hz/60 Hz, at the rated output voltage)	
Operation range	The output voltage setting is 8 V or higher	
Calibration range	Within $\pm 10\%$ (difference between the output voltage and measured value) The output voltage should be within the allowed voltage setting range of the product.	
Accuracy	Within $\pm 0.5\text{ V} / \pm 1.0\text{ V}$ (in the case of DC or 40 Hz to 550 Hz, 50 V or higher output voltage, resistance load, the output current is the maximum current or less)	

10.21 Autocal (Output Voltage Compensation)

When the Autocal (Automatic Calibration) is on, the detection point voltage is always measured, and the output voltage is continuously corrected so that its effective value is equal to the output voltage setting value. The ratio (correction factor) of the detection point voltage to the output voltage setting value is used until the Autocal or the power is turned off. Therefore, the detection point voltage is not necessarily maintained if the load changes while the Autocal is on. The detection point can be switched between the V sensing terminal (remote sensing on) and the output terminal (remote sensing off).

Unlike the AGC, it cannot follow a load fluctuation because it does not keep track of the voltage. On the other hand, when the load is stable, it has a merit of short response time on changing the output voltage setting.

Effective only for AC-INT, AC-VCA, AC-SYNC, DC-INT, and DC-VCA and when the waveform is sine wave or DC. It is turned off when the Sequence or Simulation is selected.

It cannot be selected when the AGC is set to on. However, in case the stand-by state of sequence mode (step 0) effective only for AC-INT, ACDC-INT and DC-INT and when the waveform is sine wave or DC. Autocal cannot be activated unless either AC voltage or DC voltage setting is 0 V for ACDC-INT. Also, Autocal is turned off once when you change AC/DC mode.

It cannot be selected when the AGC is set to on.

It cannot be set to on in CC mode.

	Single-unit	Multi-unit system
Restriction when on	The output voltage setting is 8 V or higher	
Calibration range *66	Within $\pm 10\%$ (difference between the output voltage and measured value) The output voltage should be within the allowed voltage setting range of the product.	
Accuracy *66	Within $\pm 0.5\text{ V} / \pm 1.0\text{ V}$ (in the case of DC or 40 Hz to 550 Hz, 50 V or higher output voltage, resistance load, the output current is the maximum current or less)	

*66: The values of the calibration range and accuracy are the ones at the time when the Autocal is turned on.

10.22 Sequence

Effective only for AC-INT, ACDC-INT, and DC-INT. Both CV and CC modes are supported.

	Single-unit 1P2W system	Polyphase system (1P3W system, 3P4W system)
Number of memories	5 (non-volatile)	
Number of steps	Maximum 255 (for each sequence)	
Setting range of Step Time	0.0010 s to 999.9999 s	
Intra-Step behavior	Constant, Keep, Linear Sweep	
Parameter *67 *68 *69	Output range AC/DC mode (The signal source is fixed to INT) (The above 2 items are common within one sequence) AC voltage or AC current, frequency, waveform DC voltage or DC current Start Phase Stop Phase Step termination Jump count (1 to 9999, or infinite) Specification of the Jump-to step Synchronous step output (2bit) Specification of the branch step Trigger output	Output range AC/DC mode (The signal source is fixed to INT) (The above 2 items are common within one sequence) AC voltage or AC current, frequency, waveform DC voltage or DC current *70 Start Phase Stop Phase Phase angle Step termination Jump count (1 to 9999, or infinite) Specification of the Jump-to step Synchronous step output (2bit) Specification of the branch step Trigger output
Sequence control	Start Stop Hold Resume Branch 1, Branch 2	

*67: The output of AC voltage or AC current, Frequency, and DC voltage or DC current of step 0 can be changed on Sequence Edit View during output ON.

*68: For DC-INT, the AC phase voltage, frequency, waveform, Start Phase, and Stop Phase cannot be set.

*69: The Start Phase and Stop Phase are specified for the L1 phase, and the component of the Phase angle setting is added to them for the other phases.

*70: DC voltage can only be set in CV mode and for the 1P3W system.

10.23 Simulation

This allows you to simulate power line abnormalities, such as blackout, voltage rise, voltage drop, abrupt phase change, and abrupt frequency change. It can be used only for AC, sine wave, and ACDC-INT. Note that it does not support IEC or other standards test. When performing the tests specified by the standards, use appropriate peripheral equipment. In the 1P3W system and the 3P4W system, only the balanced mode is available.

CC modes are not supported.

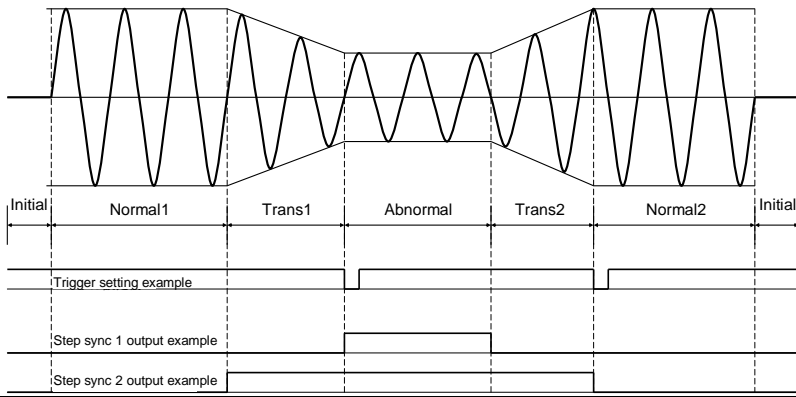
	Single-unit	Multi-unit system
Number of memories	5 (non-volatile)	
Number of steps	6 (Initial, Normal 1, Trans 1, Abnormal, Trans 2, Normal 2)	
Setting range of Step Time	0.0010 s to 999.9999 s (0 s is available only for the Transition Step)	
Parameter	<p>Output range (The above item is common within the Simulation)</p> <p>AC voltage Frequency Waveform (sine wave only) Start Phase (excluding the Transition Step) Stop Phase (excluding the Transition Step) Synchronous step output (2bit) Trigger output Repeat count (1 to 9999 times or infinite)</p> 	
Simulation control	Start Stop	

10.24 Clipped Sine Wave

The peak clipped sine wave can be output, based on the crest factor (CF) setting or the percent setting to the peak value. CC modes are not supported.

		Single-unit	Multi-unit system
Number of memories		3 (non-volatile)	
CF *71 *72	Variable range	1.10 to 1.41	
	Factory default	1.41	
	Setting resolution	0.01	
	Effective value correction	Yes	
Clip ratio *71 *73	Variable range	40.0 % to 100.0 %	
	Factory default	100.0 %	
	Setting resolution	0.1 %	
	Effective value correction	None	

*71: In the 1P3W system and the 3P4W system, these are the settings for the phase voltage.

*72: The crest factor is represented as “voltage peak value/voltage effective value.” It is 1.41 for sine wave.

*73: When the clip ratio is specified, the peak is clipped by the voltage corresponding to the specified % to the peak value of the setting voltage (100 %).

Example) For the output voltage setting of 100 Vrms and the clip rate of 80 %, the peak is clipped at 113.1 Vpk.

10.25 External Signal Input

The external signal input works differently depending on the selection of the signal source.

10.25.1 Voltage and Current Setting Signal Input (Signal Source VCA only)

This is the signal to set the output voltage or the output current amplitude of the internal signal source (DC input).

Output voltage (Vpk) = Voltage setting signal (Vdc) × Gain (Vpk/Vdc)

Example 1) For the AC/DC mode = AC, signal source = VCA, the gain of 100.0, and the voltage setting signal input of 1 Vdc, the output voltage is 100 Vpk.

Example 2) For the AC/DC mode = AC, signal source = VCA, the gain of 141.4, and the voltage setting signal input of 1 Vdc, the output voltage is 141.4 Vpk (=100 Vrms).

Output current (Apk) = Voltage setting signal (Vdc) × Gain (Apk/Vdc)

Example 1) For the AC/DC mode = AC, signal source = VCA, the gain of 20.00, and the voltage setting signal input of 1 Vdc, the output current is 20 Apk.

Example 2) For the AC/DC mode = AC, signal source = VCA, the gain of 28.28, and the voltage setting signal input of 1 Vdc, the output current is 28.28 Apk (=20 Arms).

	Single-unit	Multi-unit system	Factory default
Gain setting range (CV mode) *74	100 V range: 0.0 to 227.0 times		100
	200 V range: 0.0 to 454.0 times		200
Setting resolution	0.1		
Gain setting range (CC mode) *74 *75	20 A range 0 to 80 A / V	20 A range (1P2W system) 0 to 80 A / V × N (1P3W system, 3P4W system) 0 to 80 A / V × (1 + B)	(Single-unit) 20 A / V (1P2W system) 20 A / V × N (1P3W system, 3P4W system) 20 A / V × (1 + B)
	10 A range 0 to 40 A / V	10 A range (1P2W system) 0 to 40 A / V × N (1P3W system, 3P4W system) 0 to 40 A / V × (1 + B)	(Single-unit) 10 A / V (1P2W system) 10 A / V × N (1P3W system, 3P4W system) 10 A / V × (1 + B)
Setting resolution	0.01		
Gain accuracy *76	±5 %		
Input terminal	BNC connector (rear panel, unbalanced) Also used as the external synchronization signal input		
Input impedance	1 MΩ		
Input voltage range	±2.2 V (A/D resolution 10 bit)		
Nondestructive maximum input voltage	±10 V		

*74: In the 1P3W system and the 3P4W system, the setting is common to all the phases.

10. Specifications

*75: “N” represents the number of units configured for the entire system, and “B” represents the number of boost-up units for each phase. The range of “N” is from 2 to 9 units, and the range of “B” is from 0 to 2 units. See *Figure 10-1*.

When a multi-unit system of “N” or “(1+B)” units is configured, the output resolution is “N” or “(1+B)” times the setting resolution.

*76: DC or 45 Hz to 550 Hz, the gain is the factory default, no load, and the rated output voltage (CV mode) or maximum current (CC mode).



10.25.2 External Synchronous Signal Input (Signal Source SYNC only)

This is the signal to synchronize the frequency of the internal signal source with the one of the external signal source.

When the signal source is SYNC, you can select whether to synchronize with this external signal input or the power input frequency of the product. When synchronizing with the power input frequency, no signal input is needed.

	Single-unit	Multi-unit system	Factory default
Synchronization signal source switch	External synchronization signal (EXT) or Power input (LINE)		LINE
Synchronization frequency range	40 Hz to 550 Hz		
Input terminal	BNC connector (rear panel, unbalanced)		
Input impedance	1 M Ω		
Threshold of input voltage	Low: 0.8 V or less, High: 2.6 V or more, chassis potential		
Minimum pulse width	300 μ s		
Nondestructive maximum input voltage	\pm 10 V		

10.26 General Function

		Description	Factory default
LCD display setting	Brightness	0 to 99	50
Beep (key operation and erroneous operation, limiter operation)	*77	On or Off Alarms on abnormal situation regardless of the setting	On
Key lock	*77	On or Off On: Only key lock-off and output-off are available	Off
High impedance output off	*77 *78 *79	Setting high impedance output off function (In CC mode, it is fixed to Disable.) Enable: The output is switched off in a high impedance state. Disable: In CV mode, the output is switched off after the output voltage is set to 0 V. In CC mode, the output is switched off after the output current is set to 0 A.	Disable
Output relay control	*77 *79	Setting output relay operation. (Enable can only be set when the high-impedance output off function is disabled. In CC mode, it is fixed to Disable.) Enable: The output relay is used to turn the output on/off Disable: The output relay is not used. High impedance to turn the output off	Enable
Output setting at power-on		On or Off On: Output on after power-on	Off
Trigger output setting		Polarity: positive  or negative  Pulse width: 0.1 ms to 10 ms (resolution 0.1 ms)	Negative 10 ms
Time unit setting for Sequence and Simulation		ms or s	s
Reset function		Resets the items stored in the System Setting Memory (excluding the external interface setting and external control setting) and the items that are to be reset at power-on, to the factory default settings.	
Date and time setting		Year (4 digits), month, day (also for leap years), hour (24-hour system), minute, second	

*77: In the multi-unit system, phase master and booster are linked to the system master.

*78: When the high impedance output off function is enabled, the output is switched off in a high impedance state, so that the output can be switched off without discharging the electric charge of the capacitors or batteries connected to the output terminals.

If the high impedance output off function is disabled, the output voltage is set to 0 V before the output is switched off, thereby suppressing voltage surges when the output is switched off.

*79: In CC mode, the output relay control is disabled (always on), and setting high impedance output off function is fixed to Disable. In CV mode, see table below.

		Output relay control	
		Enable (on-off operation)	Disable (always on)
High impedance output off	Enable	Impossible	Possible
	Disable (Output off after 0 V)	Possible	Possible

10.27 Memory Function

You can save basic settings (AC/DC mode, signal source, output range, AC setting, DC setting, current limiter, setting range limit, etc.) for each output phase configuration and each output mode (CV, CC mode) in the non-volatile Basic Setting Memory of No.1 to No.30, and recall them to use when the output is off. The No.1 setting is restored at power-on. The No.0 setting includes the setting items for the factory default.

The external control, display, and other settings are saved in non-volatile System Setting Memory when they are changed by the panel operation or remote command.

The Sequence, Simulation, and clipped sine wave are saved in their own non-volatile memories.

The RECALL key and numeric keypad can be used to directly recall the basic setting memory from No. 0 to No. 9.

Items in the Basic Setting Memory *80

	Factory default
Number of connected units *81	1 unit
Output range	100 V range
AC/DC mode	AC
Signal source	INT
External synchronization signal (LINE or EXT)	LINE
AC voltage setting	0 V
Frequency	50 Hz
Output waveform	Sine wave
Output on phase	0.0°
Output off phase	Enable, 0.0°
Soft start and soft stop	Disable
Phase voltage/Line voltage setting selection	Phase voltage
Phase angle setting	1P3W L1: 0°, L2: 180° 3P4W L1: 0°, L2: 120°, L3: 240°
Balanced/Unbalanced	Balanced
DC voltage setting	0 V
Current limiter, Voltage limiter	See 10.16, 10.17
Setting range limit	See 10.18
External input gain	100 / 200

*80: Some items do not exist depending on the AC/DC mode or signal source.

*81: If there is a discrepancy between the number of connected units stored and the actual number of connected units, the items relating to the number of connected units are reconciled.

Items in the System Setting Memory

	Factory default
Master-slave	Disable
Output phase configuration	1P2W
Output function	Continuous
Output mode	CV mode
DC offset setting	0 mV (CV mode), 0 mA (CC mode)
Measurement unit selection	rms
Remote sensing	Off
AGC	Off
General function	See 10.26 (excluding the time unit setting of the Step Time for the Sequence and Simulation)
Waveform monitor output target	Current (L1 phase)
External interface	USB
External control	Disable
Clipped sine wave	See 10.24
SHUT DOWN input	Disable

10.28 Self-diagnosis/Protection Function

At power-on	Description
ROM check	Checks the internal ROM.
RAM check	Checks the internal RAM.
Basic Setting Memory check	Checks the Basic Setting Memory.
System Setting Memory check	Checks the System Setting Memory.
Waveform Memory check	Checks the Waveform Memory.
Sequence Memory check	Checks the Sequence Memory.
Simulation Memory check	Checks the Simulation Memory.
Adjustment value memory check	Checks the adjustment data memory.
Version check	Checks the version of the internal software.
System configuration check	Checks the polyphase system.

While energizing	Description
Abnormal output	Turns off the panel display and output when an output overvoltage or overcurrent is detected.
Power unit error	Turns off the panel display and output when a power unit error is detected.
Internal control error	Turns off the panel display and output when an internal communication or other error is detected. Also stops all the operations excluding power-off.

10.29 CONTROL I/O

When you enabled the external control from the menu, you can control this product by using the external signal (or non-voltage contact). The state output is always on. The detection and state switching are done at 10 ms-cycle or less. If the Remote state is achieved by the external interface, a control input is ignored.

Only the system master can use this function when configuring a multi-unit system. Phase masters and boosters cannot be used.

Item	Description
Disable	Disable the control input of the CONTROL I/O. The status output signal is output.
Enable	Enable the CONTROL I/O.

Item		Description	
Control input	External control input	Enable or Disable	
	Input level	Low: 0.8 V or less, High: 2.6 V or more chassis potential	
	Nondestructive maximum input	+10 V / -5 V	
	Input impedance	Pull-up to +5 V via 47 kΩ	
	Control	Output Off	Falling Off
		Output On	Falling On
		Sequence start/resume *82	Falling Start
		Stop of sequence *82	Falling Stop
		Sequence is in the Hold status	Falling Hold
		Sequence branch 1	Falling Branch start
		Sequence branch 2	Falling Branch start
		Memory recall (+ compile) *83	Falling Recall
		Memory specification 1	Specify 0 to 3 *84 (Equivalent to memory 1 to 4, respectively)
		Memory specification 2	
Clear the current peak-hold value	Falling Clear		



*82: Sequence start and stop of the control input are effective for the Simulation as well. Also, step sync output 1 and 2 of the control output are effective for the Simulation as well.

*83: The memory recall input of the control input recalls the setting memory for the Normal (Continuous), the Sequence Memory for the Sequence, and the Simulation Memory for the Simulation. For the Sequence and Simulation, the compile data is also included.

*84: The memory specification is shown in the table below.

	Memory No.			
	1	2	3	4
Specify	0	1	2	3
Memory specification 1	Low	High	Low	High
Memory specification 2	Low	Low	High	High

(Continued)

Item		Description	Factory default	
State output	Output level	Low: 0.4 V or less, High: 2.7 V or more chassis potential		
	Output impedance	220 Ω		
	Polarity	*85	Positive or Negative	Negative
	Status	Power On/Off	Low: Off, High: On	
		Output On/Off*	Low: On, High: Off (Negative) Low: Off, High: On (Positive)	
		Protection operation*	Low: Active, High: None (Negative) Low: None, High: Active (Positive)	
		Limiter operation*	Low: Active, High: None (Negative) Low: None, High: Active (Positive)	
		AGC/Autocal setting state*	Low: On, High: Off (Negative) Low: Off, High: On (Positive)	
		Software busy*	Low: Busy, High: Ready (Negative) Low: Ready, High: Busy (Positive)	
		Output range	Low: 200 V, High: 100 V (CV mode) Low: 10 A, High: 20 A (CC mode)	
		Output mode	Low: CV mode, High: CC mode	
		Output phase configuration	Low: Single-unit or 1P2W system High: 1P3W system or 3P4W system	
		Sequence operation	*86	High level or Low level
	Step sync 1			
Sequence operation	*86	High level or Low level		
Step sync 2				
Trigger		Positive  or Negative 		
Terminal	D-sub 25-pin multi-connector (rear panel, female, M2.6 screw)			

*85: Polarity reverse (collective) is available only for the state with *.

*86: Sequence step sync output 1 and 2 of the control output are effective for the Simulation as well. Step sync code specification is shown in the table below.

bit	Step sync code			
	LL	LH	HL	HH
0	Low	High	Low	High
1	Low	Low	High	High

10.30 External Interface

This is the interface to control the product from an external computer. The USB, RS232, GPIB, and LAN interfaces are provided by default.

The command language is compliant with the SCPI Specification Version 1999.0. (Factory default is USB). It is not possible to use several interfaces at the same time.

USB interface (USB2.0, Type B) *87

Item	Description
Device class	USBTMC-USB488 subclass
ID	Already assigned for each device
Terminator	“LF”
Signal rate	Full-Speed USB

*87: The use of USB hub may cause a communication failure. It is recommended to use a fully-shielded, short cable.

10. Specifications

RS232 interface *88 *89

Item	Description or Selection	Factory default
Terminal	D-sub 9-pin (male, UNC #4-40 screw)	
Baud rate	9600 / 19200	9600 bps
Terminator	“CR” “LF” / “CR” / “LF”	“CR” “LF”
Parity	None/Odd/Even	None
Stop bit	1 / 2	1 bit
Data bit	7 / 8	8 bit
Flow control	None/Hardware/Software	None

*88: Binary transmission is not supported.

*89: Use a cross cable.

GPIO interface (IEEE488.1 std 1987, IEEE std. 488.2-1992)

Item	Description or Selection	Factory default
Address	0 to 30	2
Terminator	“LF”	
Interface function	SH1, AH1, T6, L4, SR1, RL1, PP0, DC1, DT0, C0	

LAN interface (IEEE802.3) *90

Item	Description or Selection	Factory default
Terminal	RJ-45 modular jack	
Transmission method	Ethernet (100BASE-TX / 10BASE-T)	
Communication protocol	SCPI-RAW	
Terminator	“LF”	
IP address setting	Auto, Fixed	Auto

*90: Binary transmission is not supported.

10.31 USB Memory Interface

Commercial USB memory sticks can be used.

	Description
Available memory *91	USB 2.0-compliant product
Connector	USB-A (front panel)
Format	FAT32
Signal rate	Full-Speed USB (12 Mbps maximum)
Writable/readable contents	Basic Setting Memory, Sequence, Simulation
File operation	Create dedicated directory, rename, delete, load, and save 2-byte characters (Japanese, etc.) are not supported.

*91: We do not guarantee that all USB memories can be operational with this product.

10.32 Waveform Monitor Output

This can monitor the waveform of the output voltage or current. (only one terminal)

Only the system master can use this function when configuring a 1P2W system.

Only the system master and phase master can use this function when configuring a 1P3W system or 3P4W system.

	Single-unit	Multi-unit system
Monitored	Output phase voltage or output phase current (switched)	
Accuracy *92	±5 %	
Output terminal	BNC connector (rear panel, unbalanced)	
Output impedance	600 Ω	
Phase voltage gain (V/V)	$\frac{1}{200} / \frac{1}{400}$	
Phase current gain (V/A) *93	$\frac{1}{50} / \frac{1}{25}$	When selecting own unit $\frac{1}{50} / \frac{1}{25}$ 1P2W system $\frac{1}{50 \times N} / \frac{1}{25 \times N}$ 1P3W system, 3P4W system $\frac{1}{50 \times (1+B)} / \frac{1}{25 \times (1+B)}$

*92: No load on the monitor output, the rated output voltage, the resistance load at the maximum current.

*93: “N” represents the number of units configured for the entire system, and “B” represents the number of boost-up units for each phase. The range of “N” is from 2 to 9 units, and the range of “B” is from 0 to 2 units. See *Figure 10-1*.

10.33 SHUT DOWN Input

An external signal (or no-voltage contact) forcibly switches off the output to stop operation. Either Enable or Disable can be selected by the setting. The operation is stopped when the input is high, and normal operation is performed when the input is low. To recover after SHUT DOWN, restart the power supply.

	Single-unit	Multi-unit system
Input terminal	Spring type terminal AWG 24 to 16	
Input level	Low: 0.8 V or less, High: 2.6 V or more chassis potential	
Nondestructive maximum input	+10 V / -5 V	
Input impedance	Pull-up to +5 V via 5 kΩ	
Input signal *94	Low or High (operation stops on high). Enable or Disable selectable.	

*94: In the multi-unit system, phase master and booster are linked to the system master. The input terminals of the phase master or the booster are disabled.

10.34 Operation Environment

	All models
Operation Environment	Indoor, Pollution Degree 2
Altitude	2000 m or lower
Operating temperature/ humidity	0 °C to +50 °C, 5 % to 85 %RH The absolute humidity should be 1 to 25 g/m ³ , without dew condensation. On some specifications, the temperature range limit is stricter.
Storage temperature/ humidity	-10 °C to +60 °C, 5 % to 95 %RH The absolute humidity should be 1 to 29 g/m ³ , without dew condensation.

Figure 10-2 shows the ranges of the ambient temperature and the humidity.

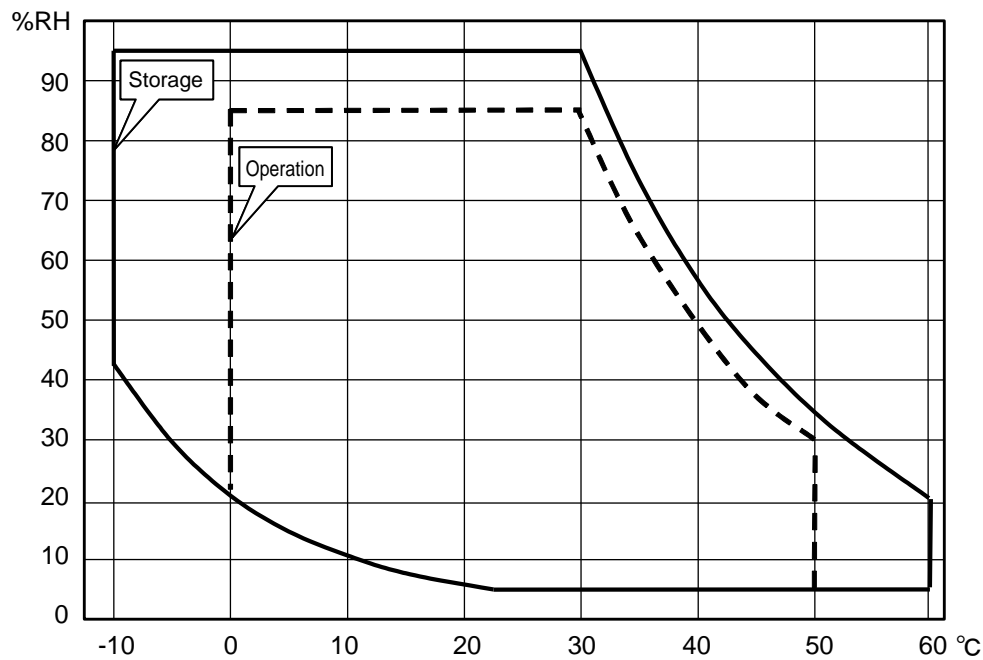

Figure 10-2 Range of Ambient Temperature/Humidity

10.35 Externals, Mass, and Terminal Block

	Single-unit
Dimensions (W×H×D) (Excluding projections)	430×130×650 mm
Mass	20 kg approx.
Power input terminal (rear)	M5 screw
Output terminal (rear)	M5 screw
V sensing terminal (rear)	Spring type terminal AWG 24 to 16

10.36 Option

Option name	Description	Remarks
System Cable PA-001-3879 (0.5 m) PA-001-3880 (1 m) PA-001-3881 (2 m)	Allows you to configure the polyphase system or boost-up by using multiple units.	On order and after purchase
Rack-Mount Adapter EIA (inch) PA-001-3882 JIS (mm) PA-001-3883	The rack-mount adapter is a set of brackets used to mount the product on the EIA or JIS standard compliant rack.	On order and after purchase
Replacement Air Filter PA-001-3884	Replacement air filter.	On order and after purchase
Power Cable (Approx. 3 m) PA-001-3885	Cables for the power input.	On order and after purchase

10.37 Outline Dimensional Drawing

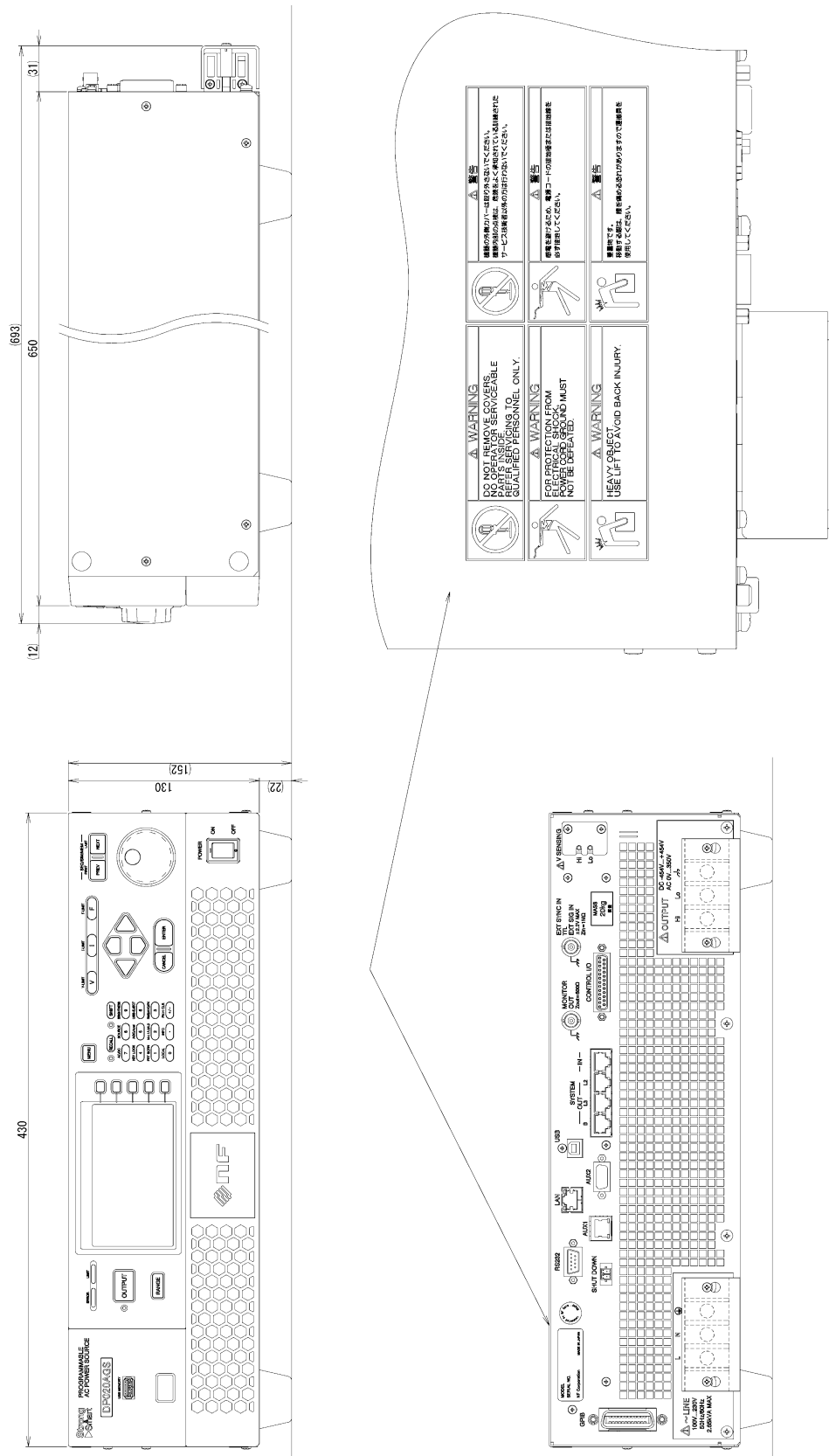

Figure 10-3 DP020AGS

WARRANTY

NF Corporation certifies that this product was thoroughly tested and inspected and found to meet its published specifications when it was shipped from our factory. In the unlikely event that you experience an issue during use, please contact our company or agency of our company from which you purchased the product.

All NF products are warranted against defects in materials and workmanship for a period of one year from the date of shipment. During the warranty period, NF will repair the defective product without any charge for the parts and labor.

For repair service under warranty, the product must be returned to either NF or an agent designated by NF. The Purchaser shall prepay all shipping cost, duties and taxes for the product to NF from another country, and NF shall pay shipping charges to return the product to the purchaser.

This warranty shall not apply when corresponding to following particulars.

- A) Failure caused by improper handling or use of the product in a manner that does not conform with the provisions of the Instruction Manual.
- B) Failure or damage caused by transport, dropping, or other handling of the product after purchase.
- C) Failure caused by repair, adjustment, or modification of the product by a company, organization, or individual not approved by NF.
- D) Failure caused by abnormal voltage or the influence of equipment connected to this product.
- E) Failure caused by the influence of supply parts from the customer.
- F) Failure caused by such as corrosion that originate in the use of causticity gas, organic solvent, and chemical.
- G) Failure caused by the insect or small animal that invaded from the outside.
- H) Failure or damage caused by fire, earthquakes, flood damage, lightning, war, or other uncontrollable accident.
- I) Failure caused by the reason that was not able to be foreseen by the science and technology level when shipped from our company.
- J) Replacement and replenishment of consumables such as batteries.

NF Corporation

WABUN: (DA00104048)

If there are any misplaced or missing pages, we will replace the manual. Contact the sales representative.

NOTES

- Reproduction of the contents of this manual is forbidden by applicable laws.
- The contents of this manual may be revised without notice.
- Information provided in this manual is intended to be accurate and reliable. However, we assume no responsibility for any damage regarding the contents of this manual.
- We assume no responsibility for influences resulting from the operations in this manual.

©Copyright 2024, **NF Corporation**

Programmable AC Power Source

DP020AGS

Instruction Manual

NF Corporation

6-3-20, Tsunashima Higashi, Kohoku-ku, Yokohama

223-8508 JAPAN

Phone +81-45-545-8111 Fax +81-45-545-8191

