



10kV AC/DC AMPLIFIER

HVA4321

INSTRUCTION MANUAL

DA00012063-001

10kV AC/DC AMPLIFIER

HVA4321

Instruction Manual

This unit generates high voltage. Incorrect operation may result in death or injury. To prevent death or injury, please read this manual carefully. Keep this manual near the unit so that operators may read at any time.

— Preface —

Thank you for purchasing the 10 kV AC/DC amplifier.

To ensure safe and proper use of this electric equipment, please read first INSTRUCTIONS FOR SAFE USE on the following pages.

■ Caution Symbols Used in This Manual

The following caution symbols are used in this manual. Be sure to observe these caution symbols and their contents to ensure the safety of the user and avoid damage to the equipment.

WARNING

This mark indicates information for the avoidance of a hazard such as electric shock that may endanger human life or cause injury during handling of the equipment.

CAUTION

This mark indicates information for the avoidance of damage to the equipment during handling.

● This manual has the following chapter organization.

If reading this manual for the first time, start from Chapter 1.

1. OVERVIEW

Describes various items that must be checked prior to using this product.

2. PREPARATIONS BEFORE USE

Describes various cautions regarding preparations to be made before installation or operation.

3. PART NAMES AND FUNCTIONS

Describes functions, movements and basic operations for knobs on the panel. Read this manual while operating the unit.

4. OPERATION

Describes operation of this product.

5. REPRESENTATIVE CHARACTERISTICS

Describes representative characteristic of this product.

6. TROUBLESHOOTING

Describes corrective actions when problems occur.

7. MAINTENANCE

Describes basic operation tests and daily maintenance procedures.

8. SPECIFICATIONS

Lists the specifications (functions and performance).

— Safety Precautions —

To ensure safe use, be sure to observe the following warnings and cautions.

NF Corporation shall not be held liable for damages that arise from a failure to observe these warnings and cautions.

This product is a Class 1 product (with protective conductor terminal) that conforms to the JIS and IEC insulation standards.

- **Be sure to observe the contents of this instruction manual.**

This instruction manual contains information for the safe operation and use of this product.

Be sure to read this information first before using this product.

All the warnings in the instruction manual must be heeded to prevent hazards that may cause major accidents.

- **Be sure to ground the product.**

This product uses a line filter and must be grounded to avoid the risk of electric shock.

To prevent electric shock, be sure to safely implement grounding according to Japanese Standard for Electrical Equipment Technology D (Type 3) or higher.

When the 3-pin power plug is connected to the 3-pin power outlet with protective ground contact, this product is automatically grounded.

To use 3-pin 2-pin conversion adapter, be sure to connect the ground line (green) of the conversion adapter to the ground terminal near the outlet.

If the ground terminal is available at the back panel, the terminal may be grounded with a wire equivalent to or larger than the thickness of the power cable.

- **Check the power supply voltage.**

This product operates on the power supply voltage indicated in Grounding and Power Supply Connection in this instruction manual.

Prior to connecting the power supply, check that the voltage of the power supply matches the rated power supply of the product.

- **Observe the fuse rating.**

Fire may occur. Use the rated fuse specified in Grounding and Power Supply Connection in the instruction manual.

When the fuse is replaced, be sure to disconnect the power cable from the outlet.

- **In case of suspected anomaly**

If this product emits smoke, an abnormal smell, or abnormal noise, immediately disconnect the power cable and stop operation.

If such an anomaly occurs, do not use this product until it has been repaired, and immediately report the problem to the location of purchase (either NF Corporation or your distributor).

- **Do not use this product when gas is present.**

Otherwise, it may cause an explosion.

- **Do not remove the cover.**

This product contains high-voltage parts. Absolutely never remove its cover. Even when the inside of this product needs to be inspected, do not touch the inside.

All such inspections are to be performed by service technicians designated by NF Corporation.

- **Do not modify this product.**

Absolutely never modify this product, as this may cause new hazards and may disqualify this product from repair in case of failure.

- **Safety-related symbols**

The general definitions of the safety-related symbols used on this product and in the instruction manual are provided below.



Instruction manual reference symbol

This symbol is displayed to alert the user to potential danger and refer him/her to the instruction manual.



Electric shock danger symbol

This symbol indicates locations that present a risk of electric shock under specific conditions.



Protective terminal grounding symbol

This symbol indicates terminals that require grounding to prevent electric shock. Before operation of the unit, be sure to connect this terminal to the ground of type 3 or higher. (When the 3-pin power cable is connected to the 3-pin outlet, it is not necessary to connect this ground terminal.)



Warning Symbol

This symbol indicates information for avoiding danger to human life or bodily injury such as electric shock while handling this product.



Caution Symbol

This symbol indicates information for preventing damage to the product when handling it.

- **Other symbols**



This symbol indicates the "ON" position of the power switch.



This symbol indicates the "OFF" position of the power switch.



This symbol indicates that the external conductor of the connector is connected to the case.



This symbol indicates that the external conductor of the connector is connected to the signal ground.

Contents

	Page
1. Overview	
1.1 Features.....	1-1
1.2 Function description and block diagram	1-3
1.2.1 Function description	1-3
1.2.2 Block diagram.....	1-4
Preparations before use	
2.1 Before using the HVA4321.....	2-1
2.2 Installation.....	2-2
2.3 Grounding and power supply connection.....	2-3
3. Nomenclature and functions	
3.1 Signal system.....	3-1
3.1.1 Internal DC bias signal source.....	3-1
3.1.2 External bias signal input	3-1
3.1.3 External signal input	3-2
3.1.4 Input signal ON/OFF	3-2
3.2 Amplifier	3-4
3.2.1 Amplifier operation mode	3-4
3.2.2 Amplifier control.....	3-6
3.2.3 Output	3-9
3.3 Monitor and control signal system.....	3-11
3.3.1 Monitor.....	3-11
3.3.2 Control signal system	3-12
3.4 Power supply items	3-17
3.5 Panel drawing	3-18
3.5.1 Front panel.....	3-18
3.5.2 Rear panel.....	3-19
4. Operation method	
4.1 Operation example in constant voltage mode	4-1
4.1.1 Panel setting	4-3
4.1.2 Connection of signal source and connection of load.....	4-6
4.1.3 Power supply and internal high voltage DC power supply.....	4-9
4.1.4 Signal output and adjustment.....	4-11
4.1.5 Signal OFF	4-13
4.2 Operation example in constant current mode (total)	4-14
4.2.1 Panel setting	4-16
4.2.2 Connection of signal source and connection of load.....	4-19
4.2.3 Power supply and internal high voltage DC power supply.....	4-22
4.2.4 Signal output and adjustment.....	4-24
4.2.5 Signal OFF	4-26

4.3	Operation example in constant current mode (load).....	4-27
4.3.1	Panel setting	4-29
4.3.2	Connection of signal source and connection of load.....	4-32
4.3.3	Power supply and internal high voltage DC power supply.....	4-35
4.3.4	Signal output and adjustment.....	4-37
4.3.5	Signal OFF	4-39
4.4	Operation example in constant current + constant voltage mode	4-40
4.4.1	Panel setting	4-42
4.4.2	Connection of signal source and connection of load.....	4-45
4.4.3	Power supply and internal high voltage DC power supply.....	4-48
4.4.4	Signal output and adjustment.....	4-50
4.4.5	Signal OFF	4-52
4.5	Change of load and power OFF	4-53
4.5.1	Change of load	4-53
4.5.2	Power supply OFF	4-56
4.6	Remote control.....	4-57
4.6.1	Remote control	4-57
4.6.2	Panel setting for use of remote control.....	4-58
5. Representative characteristics		
5.1	Measuring method	5-1
5.2	Characteristics in constant voltage mode	5-3
5.2.1	Frequency characteristics	5-3
5.2.2	Step response.....	5-4
5.3	Characteristics in constant current mode	5-5
5.3.1	Frequency characteristics	5-5
5.3.2	Step response.....	5-6
5.4	Characteristics in constant current and constant voltage mode	5-7
5.4.1	Frequency characteristics	5-7
5.5	Characteristics of voltage monitor and current monitor	5-8
5.5.1	Frequency characteristics	5-8
5.6	Others	5-9
5.6.1	Delay of output signal for input signal.....	5-9
5.6.2	Step response due to difference of amplitude	5-10
6. Troubleshooting		
6.1	When suspecting a fault.....	6-1
7. Maintenance		
7.1	Daily maintenance	7-1
7.2	Inspection.....	7-2
7.3	When the unit is not used for a long time.....	7-2
7.4	Performance test.....	7-3
7.4.1	Test of constant voltage mode.....	7-3
7.4.2	Test of constant current mode.....	7-4

8. Specification

8.1	Signal area	8-1
8.2	Amplifier	8-2
8.2.1	Characteristics of constant voltage mode	8-2
8.2.2	Characteristics of constant current mode.....	8-4
8.3	Output area.....	8-5
8.4	Monitor output	8-5
8.5	Other input/output signal	8-6
8.6	Protection circuit	8-7
8.7	Others	8-7
8.8	General items	8-8

Figures

	Page
Figure1-1. HVA4321 Block diagram.....	1-4
Figure2-1. Check of power OFF	2-3
Figure2-2. Check of internal high voltage DC power OFF	2-3
Figure2-3. Inserting power cable connector.....	2-4
Figure2-4. Using conversion connector	2-4
Figure2-5. Casing ground terminal	2-5
Figure3-1. Internal DC bias signal source	3-4
Figure3-2. External DC bias input	3-1
Figure3-3. External signal input.....	3-2
Figure3-4. Signal ON/OFF switch.....	3-2
Figure3-5. Operation mode switch.....	3-4
Figure3-6. Limiter and response	3-6
Figure3-7. Operation of voltage limiter (1)	3-6
Figure3-8. Operation of voltage limiter (2)	3-6
Figure3-9. Operation of current limiter	3-7
Figure3-10. Response function in constant voltage mode	3-8
Figure3-11. Response function in constant current mode	3-8
Figure3-12. Output area.....	3-9
Figure3-13. Power supply and internal high voltage DC power	3-9
Figure3-14. Return terminal	3-10
Figure3-15. Monitor output.....	3-11
Figure3-16. Status signal output.....	3-11
Figure3-17. Remote/local settings	3-12
Figure3-18. Remote control input	3-12
Figure3-19. Remote control input circuit.....	3-13
Figure3-20. Remote control of HIGH VOLTAGE POWER SUPPLY ON/OFF	3-14
Figure3-21. Remote control of signal system ON/OFF	3-14
Figure3-22. Remote control of signal ON/OFF	3-15
Figure3-23. Example of status contact output	3-16
Figure4-1. Constant voltage mode (total mode)	4-1
Figure4-2. Constant voltage mode (load mode)	4-2
Figure4-3. Internal high voltage DC power OFF	4-3
Figure4-4. Switch settings.....	4-3
Figure4-5. Output mode settings	4-4
Figure4-6. Local settings.....	4-4
Figure4-7. Limiter settings	4-5
Figure4-8. Current monitor mode settings	4-5
Figure4-9. Response settings	4-6
Figure4-10. Connection of external signal source signal.....	4-6

Figure4-11.	Connection of monitor	4-7
Figure4-12.	Connection of output cable	4-7
Figure4-13.	Power supply.....	4-9
Figure4-14.	Internal high voltage DC power ON	4-10
Figure4-15.	Using internal DC bias signal.....	4-11
Figure4-16.	Using external oscillator.....	4-12
Figure4-17.	Using external DC bias signal	4-12
Figure4-18.	Total mode	4-15
Figure4-19.	Internal high voltage DC power OFF	4-16
Figure4-20.	Switch settings.....	4-16
Figure4-21.	Output mode settings	4-17
Figure4-22.	Local settings.....	4-17
Figure4-23.	Limiter settings	4-18
Figure4-24.	Current monitor mode settings	4-18
Figure4-25.	Response settings	4-19
Figure4-26.	Connection of external signal source signal.....	4-19
Figure4-27.	Connection of monitor	4-20
Figure4-28.	Connection of output cable	4-20
Figure4-29.	Power supply.....	4-22
Figure4-30.	Internal high voltage DC power ON	4-23
Figure4-31.	Using internal DC bias signal.....	4-24
Figure4-32.	Using external oscillator.....	4-25
Figure4-33.	Using external DC bias signal	4-25
Figure4-34.	Load mode.....	4-28
Figure4-35.	Internal high voltage DC power OFF	4-29
Figure4-36.	Switch settings.....	4-29
Figure4-37.	Output mode settings	4-30
Figure4-38.	Local settings.....	4-30
Figure4-39.	Limiter settings	4-31
Figure4-40.	Current monitor mode settings	4-31
Figure4-41.	Response settings	4-32
Figure4-42.	Connection of external signal source signal.....	4-32
Figure4-43.	Connection of monitor	4-33
Figure4-44.	Connection of output cable	4-33
Figure4-45.	Power supply.....	4-35
Figure4-46.	Internal high voltage DC power ON	4-36
Figure4-47.	Using internal DC bias signal.....	4-37
Figure4-48.	Using external oscillator.....	4-38
Figure4-49.	Using external DC bias signal	4-38
Figure4-50.	Constant current constant voltage mode (total mode).....	4-41
Figure4-51.	Constant current constant voltage mode (load mode).....	4-41
Figure4-52.	Internal high voltage DC power OFF	4-42
Figure4-53.	Switch settings.....	4-42

Figures

Figure4-54.	Output mode settings	4-43
Figure4-55.	Local settings.....	4-43
Figure4-56.	Limiter settings	4-44
Figure4-57.	Current monitor mode settings	4-44
Figure4-58.	Response settings	4-45
Figure4-59.	Connection of external signal source signal.....	4-45
Figure4-60.	Connection of monitor	4-46
Figure4-61.	Connection of output cable	4-47
Figure4-62.	Power supply.....	4-48
Figure4-63.	Internal high voltage DC power ON.....	4-49
Figure4-64.	Using internal DC bias signal.....	4-50
Figure4-65.	Using external oscillator.....	4-51
Figure4-66.	Using external DC bias signal	4-51
Figure4-67.	Input signal OFF.....	4-53
Figure4-68.	Internal high voltage power supply OFF.....	4-53
Figure4-69.	Checking items before power OFF	4-54
Figure4-70.	POWER OFF	4-54
Figure4-71.	Removing high voltage cable	4-55
Figure4-72.	Remote control.....	4-57
Figure4-73.	Remote control switch	4-58
Figure5-1.	Compensation of probe	5-1
Figure5-2.	Measuring method of output voltage	5-1
Figure5-3.	Measuring method of output current	5-2
Figure5-4.	Frequency characteristics in constant voltage mode without load.....	5-3
Figure5-5.	Frequency characteristics in constant voltage mode with capacity load	5-3
Figure5-6.	Step response in constant voltage mode without load	5-4
Figure5-7.	Step response in constant voltage mode with 35 pF load	5-4
Figure5-8.	Frequency characteristics in constant current (TOTAL) mode.....	5-5
Figure5-9.	Frequency characteristics in constant current (LOAD) mode	5-5
Figure5-10.	Step response in constant current mode with 1 M Ω load	5-6
Figure5-11.	Frequency characteristics in constant current (TOTAL) + constant voltage mode	5-7
Figure5-12.	Frequency characteristics in constant current (LOAD) + constant voltage mode.....	5-7
Figure5-13.	Frequency characteristics of voltage monitor.....	5-8
Figure5-14.	Frequency characteristics of current monitor.....	5-8
Figure5-15.	Delay of input/output signal	5-9
Figure5-16.	Step response in constant voltage mode.....	5-10
Figure7-1.	How to remove fan cover	7-1
Figure7-2.	Check method of constant voltage mode	7-3
Figure7-3.	Check method of constant current mode.....	7-4
Figure8-1.	Output current.....	8-2
Figure8-2.	Voltage and current range allowed for output	8-3

Tables

	Page
Table2-1. Accessories	2-3
Table3-1. Logic of HIGH VOLTAGE POWER SUPPLY ON/OFF	3-3
Table3-2. Logic of signal system ON/OFF signal	3-3
Table3-3. Logic of SIGNAL ON/OFF signal.....	3-3
Table3-4. Status contact output signal	3-3

1. Overview

1.1	Features	1-1
1.2	Function description and block diagram	1-3
1.2.1	Function description	1-3
1.2.2	Block diagram	1-4

1.1 Features

The HVA4321 10 kV AC/DC amplifier is a constant voltage/constant current amplifier capable of ± 10 kVpk and ± 10 mApk.

Since the unit has a DC bias signal source, it can be used as a DC power supply that is individually capable of high voltage output. Since external AC signal and DC signal input are allowed, it can also be used as an amplifier capable of high voltage output.

- **Constant voltage/constant current amplifier**

The unit can be used as a constant voltage amplifier or a constant current amplifier. The unit can also be set as a constant voltage amplifier for DC signal and a constant current amplifier for AC signal.

- **Built-in DC signal source**

The unit has a built-in DC bias signal source.

- **With external signal input terminals**

The unit can be connected to the external signal source for two systems.

- **Excellent characteristics with large amplitude**

In constant voltage mode, 10 kVpk output up to 7 kHz is available.
In constant current mode, 10 kVpk output up to 4 kHz is available.
(with resistance load for both modes)

- **With output limiter function**

Output voltage limiter and output current limiter functions are available.

- **High slew rate**

In the constant voltage amplifier, the slew rate of 500 V/ μ s is achieved.

- **Two types of current mode**

In the constant current amplifier, two types of modes are available; the total mode that gives the set current output from the amplifier and the load mode that gives correct current set to the load by compensating the current leaking from stray capacitance of a wire along the path.

- **Step response waveform adjusting function**

For a step signal, fine adjustment of the response waveform can be made.

- **Correct monitor output**

Output voltage and output current can be correctly monitored.
(Voltage monitor gain: 1/1000, Current monitor gain: 1 V/10 mA)

1.1 Features

- Visual display of high voltage output

During high voltage output, the LED around the output connector lights and the revolution changes depending on the output voltage level.

- Remote control is capable.

Signals can be turned ON/OFF with an external control signal.

1.2 Function description and block diagram

1.2.1 Function description

Major functions of this unit are classified into the following:

- Signal system
- Amplifier stage
- Detection system
- High voltage power supply
- External control system

■ Signal system

The following three types of signals can be used as the signal sources:

- Signal source built into the unit that gives the DC output (DC BIAS)
- Signal from external oscillator (OSC INPUT)
- Signal from external DC signal source (EXT DC BIAS INPUT)

These signals can be used simultaneously. Signal is internally added and the input is given to the amplifier stage.

■ Amplifier stage

Input signals are separated into positive and negative signals, and each signal is transmitted to the high voltage amplifier stage through an optical fiber.

■ Detection system

Output voltage and output current are correctly detected by independently detecting and combining DC and AC components.

■ High voltage power supply

The unit is using ± 12 kV power supply to obtain the output of 10 kVpk. This power supply can be individually turned ON/OFF for safety.

■ External control system

The signal source can be turned ON/OFF with an external contact signal or TTL level signal.

1.2.2 Block diagram

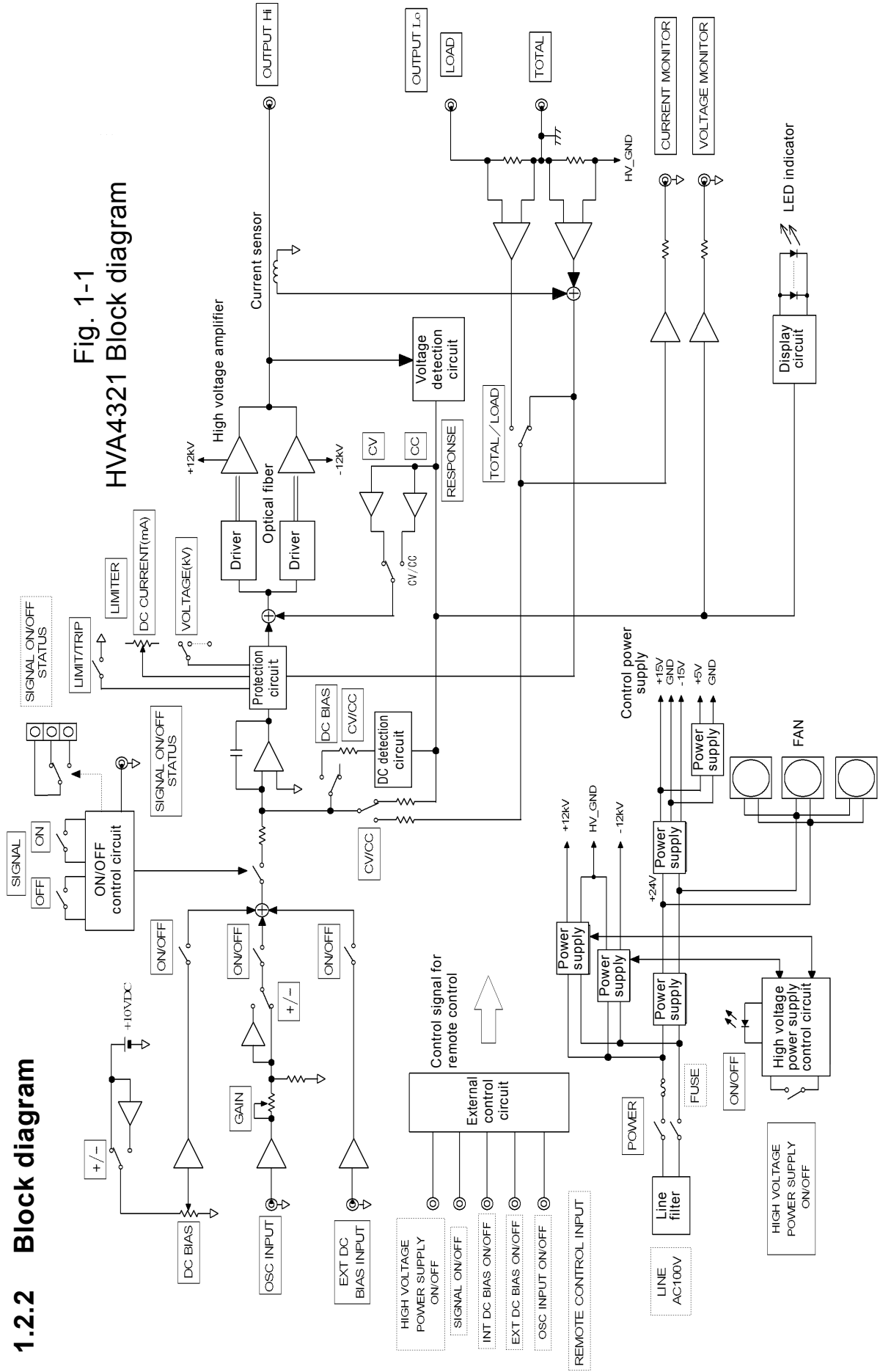

Fig. 1-1
HVA4321 Block diagram

2. Preparations before use

2.1	Before using the HVA4321	2-1
2.2	Installation	2-2
2.3	Grounding and power supply connection	2-3

2.1 Before using the HVA4321

■ Safety check

Before using the HVA4321, read the following items in the instruction manual:

- [INSTRUCTIONS FOR SAFE USE] (Described at the beginning of this instruction manual.)
- [2.3 Grounding and connection of power supply]

■ Appearance and accessories check

● Removal of product

Remove the product out of the box. If unusual statues (damage or dent) are observed on the cardboard box, make sure that the product is not adversely affected.

● Check of appearance

Make sure that there is no damage or dent on the panel surface, knob or connector.

● Check of accessories

Accessories of this product are as shown below. Make sure that the quantity is sufficient or that there is no faulty part.

Table2-1. Accessories

- | |
|--|
| <ul style="list-style-type: none"> • Instruction manual (HVA4321 instruction manual) • Power cable (10A, 125V, 2 m, 3 poles) • Fuse (time lag, 10 A/250V, ϕ 2 x 20 mm) • High voltage cable A600B80 (approx. 2 m by ALDEN) • Ground cable (0.75 mm² with M6 crimp terminal, approx. 4 m, black) • Ground cable (0.75 mm² with M6 crimp terminal, approx. 4 m, white) |
|--|

If appearance of the product shows unusual damage or if accessories are insufficient, contact us or our agent.

WARNING

This product contains high-voltage parts. Absolutely never remove its cover. Otherwise, touching the internal circuit may result in death by electric shock.

2.2 Installation

■ Before installation

This product has a positive air conditioning system with back intake and side exhaust fans to cool the inner parts. To allow ventilation of air, install this product with the side and the back by 30 cm or more apart from walls.

The range of ambient temperature and humidity for this product is as follows:

Performance assurance	: Temperature 5°C to 35°C	Humidity 45% to 85% (no condensation)
Operation assurance	: Temperature 0°C to 40°C	Humidity 10% to 85% (no condensation)
Storage condition	: Temperature -10°C to 50°C	Humidity 10% to 80% (no condensation)

■ Installation environment

Do not install or use the product in the following environments:

- Place where there is much corrosive gas, moisture, dirt, dust or conductive particles.
Failure such corrosion or deteriorated insulation may occur.
- Place where there is flammable gas.
Explosion may occur.
- Place where an object may fall
Failure may occur.
- Outdoor or place where the product is exposed to direct sunlight, or place near fire or heat
Performance may not be satisfied or failure may occur.
- Place near electromagnetic field source, high voltage device, power line, radio transmitter, cell phone, etc.
Unintended high voltage output may be given or noise may enter.
- Place where frequent vibration occurs.
Malfunction or failure may occur.

■ Installation

- Make sure that four legs at the bottom are on a flat place such as a desk.
- Never place the unit vertically with the back facing down, horizontally with the side facing down or up side down with the top facing down.
- Do not put an object on the unit.

WARNING

Do not use a radio transmitter or a cell phone around this unit. Unintended high voltage output may be given due to radio.

2.3 Grounding and power supply connection

The power supply requirements for this product are as follows:

- Power supply voltage range: Single phase AC100V \pm 10%
- Frequency range: 50/60 Hz \pm 2 Hz
- Power consumption: 800VA or less

a) Check items before connection of the power cable

Make sure that the power switch on the front panel is OFF.

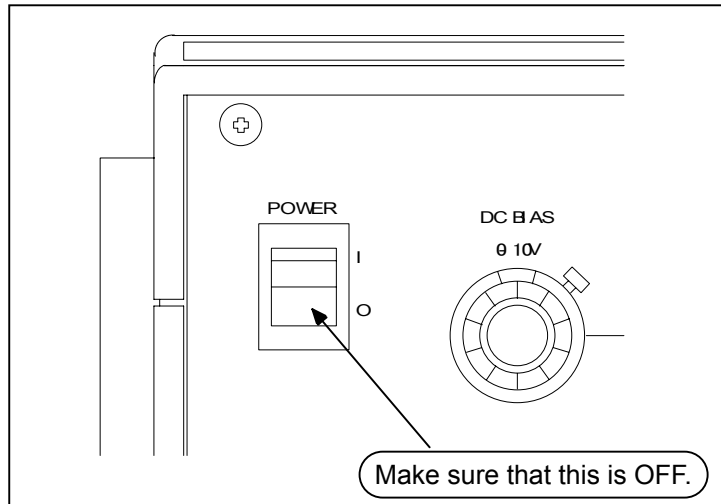

Figure2-1. Check of power OFF

Make sure that the HIGH VOLTAGE POWER SUPPLY switch on the front panel is pressed.

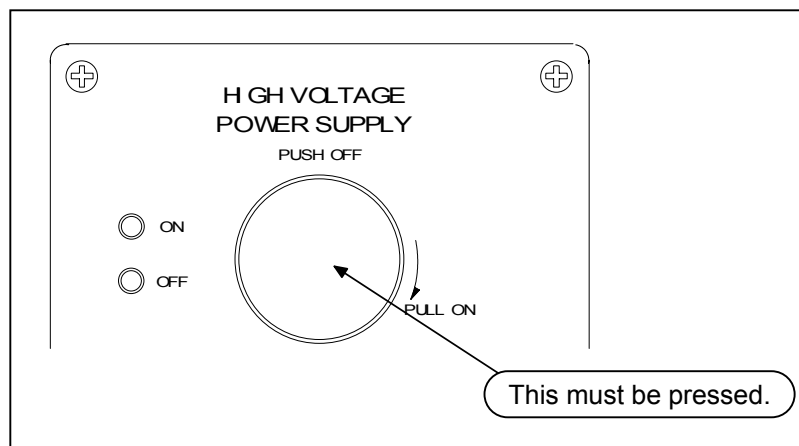

Figure2-2. Check of internal high voltage DC power OFF

2.3 Grounding and power supply connection

b) Connection of power cable

Insert the connector of the power cable accompanying the unit into the inlet of the back panel.

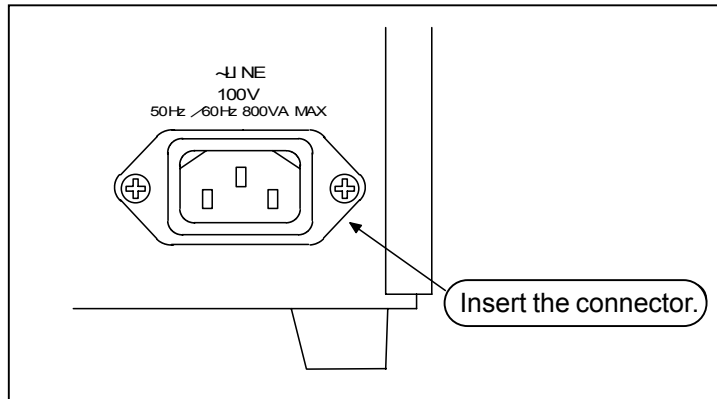

Figure2-3. Inserting power cable connector

c) Inserting the power outlet

This unit operates with the power of $AC100V \pm 10\%$. Insert the power cable plug into the power outlet with the protective ground. Use the accompanying power cable and insert it into the power outlet with the ground. The casing of the unit is then grounded.

- Using 3-pin 2-pin adapter

When 3-pin 2-pin conversion adapter is used, be sure to connect the ground wire of the conversion adapter to the ground terminal near the outlet.

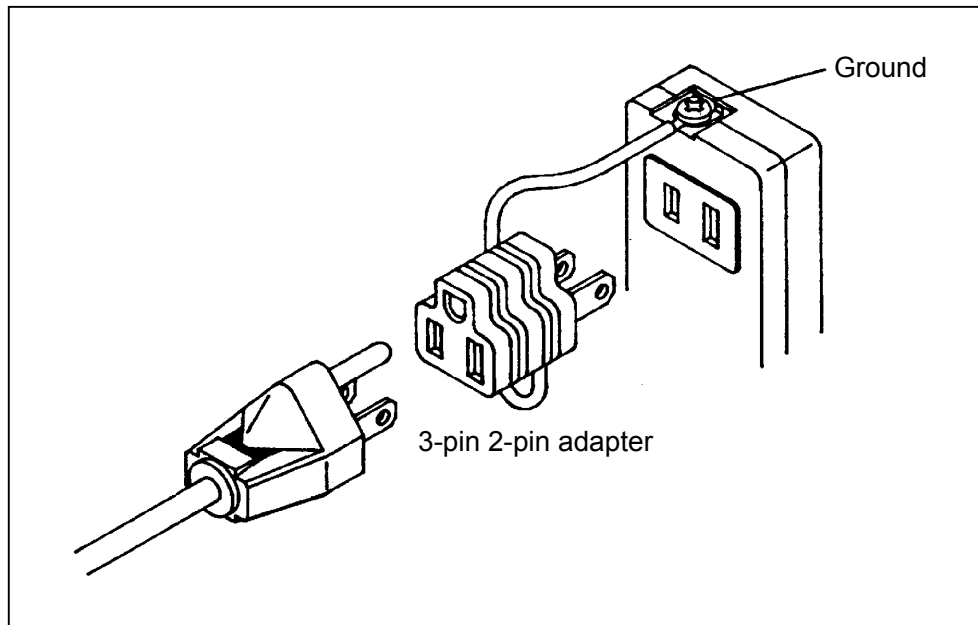

Figure2-4. Using conversion connector

- If the ground pole is not available in the adjacent area

If the power cable cannot be grounded because the ground pole is not available at the power outlet, be sure to ground the casing ground terminal at the back with a wire of 2 mm² or more.

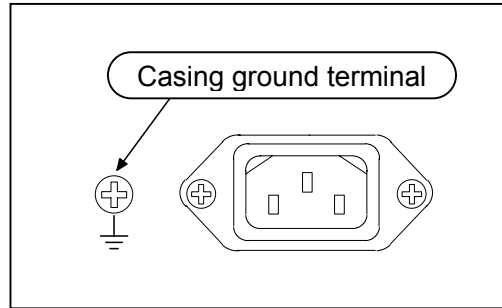

Figure2-5. Casing ground terminal

⚠ WARNING

Be sure to ground this unit for safety. Otherwise, a serious accident such as electric shock may occur.

⚠ CAUTION

The standard power cable accompanied has rated voltage of AC125V and rated current of 10A. When a power cable not accompanied is used, be careful for the rated voltage and current.

⚠ WARNING

When a fuse is replaced, be sure to disconnect the power cable from the outlet. Replace it with the same standard one.

For this product, the time lag type fuse with the rating of 10A/250V and $\phi 2 \times 20$ mm is used.

3. Nomenclature and functions

3.1	Signal system	3-1
3.1.1	Internal DC bias signal source	3-1
3.1.2	External bias signal input	3-1
3.1.3	External signal input	3-2
3.1.4	Input signal ON/OFF	3-2
3.2	Amplifier	3-4
3.2.1	Amplifier operation mode	3-4
3.2.2	Amplifier control	3-6
3.2.3	Output	3-9
3.3	Monitor and control signal system	3-11
3.3.1	Monitor	3-11
3.3.2	Control signal system	3-12
3.4	Power supply items	3-17
3.5	Panel drawing	3-18
3.5.1	Front panel	3-18
3.5.2	Rear panel	3-19

3.1 Signal system

3.1.1 Internal DC bias signal source

■ DC BIAS

This sets the output level of the internal DC bias signal source.

With combination of the pin switch, settings are available in the range of:

- In constant voltage mode
0 to ± 10 kV
- In current mode
0 to ± 10 mA
- In constant current and constant voltage mode
0 to ± 10 kV

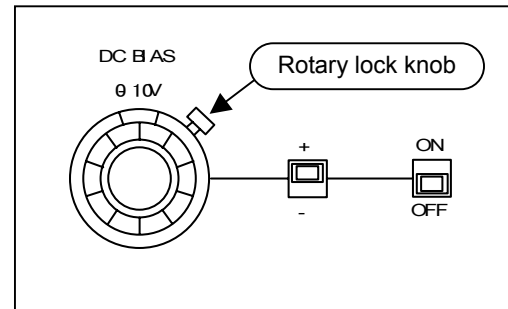

Figure3-1.
Internal DC bias signal source

To prevent inadvertent rotation of the dial, use the rotation lock function of the dial.

When the rotary lock knob is pressed clockwise, the dial is locked.

■ + / -

Polarity of the internal DC bias signal source is set. With "+", the output is positive and with "-", the output is negative.

■ ON/OFF

It is the ON/OFF switch for the internal DC bias signal source. When it is ON, the internal DC bias signal is effective.

3.1.2 External bias signal input

■ EXT DC BIAS INPUT

It is the BNC connector to give external input of the DC bias signal.

- Rated input voltage ± 10 Vpk
- Input impedance $10\text{k}\Omega \pm 10\%$

AC signal input can also be given. But the input is only for DC. Frequency characteristic and slew rate are inferior to the OSC input.

■ ON/OFF

Valid or invalid external DC bias signal is set.

When it is ON, the external DC bias signal input is valid.

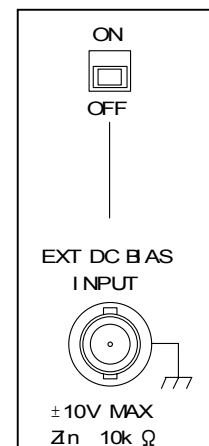

Figure3-2.
External DC bias input

3.1.3 External signal input

■ OSC INPUT

It is the BNC connector to give amplified input on this unit with an external oscillator.

- Rated input voltage ± 10 Vpk
- Input impedance $10\text{ k}\Omega \pm 10\%$

■ GAIN

The signal gain given to OSC INPUT can be fine adjusted in the range of approx. $\pm 3\%$.

It is turned with a flat tip screwdriver.

■ NORMAL/INVERT

The signal polarity in OSC INPUT is set.

In NORMAL, the input signal polarity is the same as the output signal polarity.

In INVERT, the input signal polarity is reverse to the output signal polarity.

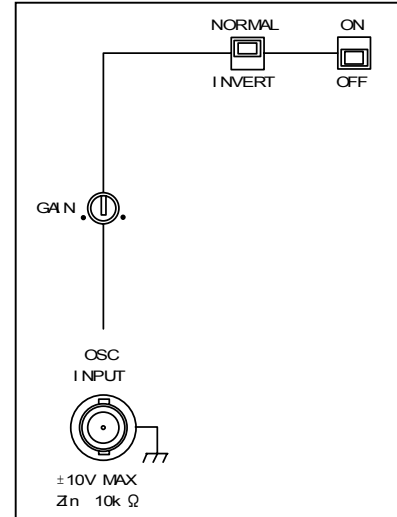

Figure3-3. External signal input

■ ON/OFF

Valid or invalid signal in OSC INPUT is set. When it is ON, the signal in OSC INPUT is valid.

⚠ CAUTION

The input voltage range to OSC INPUT and EXT DC BIAS INPUT terminals is ± 10 V.

3.1.4 Input signal ON/OFF

■ SIGNAL ON/OFF

Input to the amplifier area for INT DC BIAS, EXT DC BIAS and OSC INPUT is switched ON/OFF.

When it is ON, each input signal is given to the high voltage amplifier.

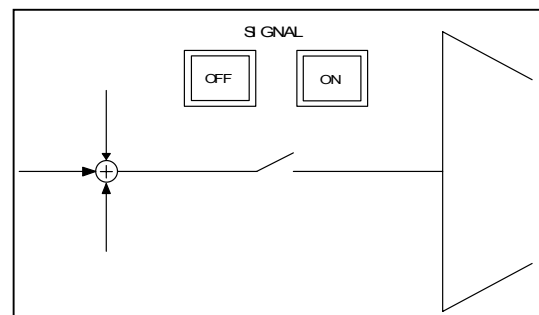

Figure3-4. Signal ON/OFF switch

⚠ WARNING

This signal ON/OFF switch has the function to set whether or not the input signal is transmitted to the high voltage amplifier. It does not switch ON/OFF the connection between the high voltage amplifying output and the output terminal of this unit.

The output from the high voltage amplifier is always connected to the output terminal.

- When the following operations are made in SIGNAL ON, SIGNAL OFF occurs forcibly.
 - When operation mode CV/CC of the amplifier is changed
 - When remote/local settings are changed

- In SIGNAL OFF, the OFF LED lights. For the following cases, the OFF LED blinks:
 - The HIGH VOLTAGE POWER SUPPLY switch is OFF.
(When the internal high voltage DC power supply is OFF)

- When the following operations are made in SIGNAL ON, SIGNAL OFF occurs forcibly and the LED changes from lighting to blinking.
An error during OFF turns the OFF LED from lighting to blinking.
 - The fan revolution stopped.
 - Temperature in the casing became high.
 - Voltage of the internal control power supply became low.
 - When the LIMIT/TRIP is set to TRIP, the current limiter circuit was activated.

In the cases above, SIGNAL ON cannot be recovered unless the cause is removed.

3.2 Amplifier

3.2.1 Amplifier operation mode

■ CV/CC

It is the switch to set the operation mode of the unit.

CV: Constant voltage mode

CC: Constant current mode

The gain of the high voltage amplifier is:

- Constant voltage mode: 1000V/1V
- Constant current mode: 1 mA/1V

■ DC BIAS CV/CC

It is the switch to set the DC signal operation mode in constant current mode.

CV: The DC signal is constant voltage mode. The AC signal is constant current mode.

CC: Both the DC signal and the AC signal are constant current mode.

For example, if a capacity load is connected in constant current mode, the capacity load has infinite impedance for DC. DC cannot be applied in constant current.

To apply DC to a capacity load, set this switch to CV so that DC output may be given in constant voltage mode. Then, constant DC bias can be applied to the capacity load.

In constant voltage mode, this function is invalid for either setting.

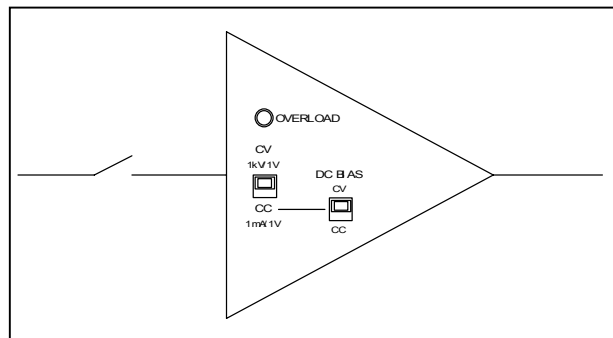

Figure3-5. Operation mode switch

The frequency at the boundary of constant voltage mode and constant current mode may vary depending on the load type and value.

- For resistance load

- For 250 k Ω Approx. 5 mHz or more
- For 1 M Ω Approx. 0.2 Hz or more

- For capacity load

- For 16 pF Approx. 100 Hz or more
- For 100 pF Approx. 50 Hz or more
- For 1000 pF Approx. 5 Hz or more

- OVERLOAD

It is the LED that lights if the unit amplifier has a fault. It lights if the unit is overloaded or the limiter is activated.

3.2.2 Amplifier control

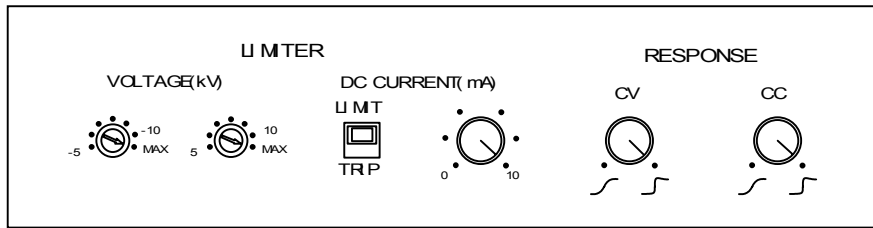

Figure3-6. Limiter and response

■ VOLTAGE (kV)

The limit value of the output voltage can be set in the range from ± 5 kV to ± 10 kV at the resolution of 1 kV. For example, when the limit values of +8 kV for positive side and -6 kV for negative side are satisfactory, make settings to +8 kV and -6 kV. Set the value with a flat tip screwdriver.

When MAX is set, the limit is invalid. The amplifier can give the maximum voltage output available.

● In constant voltage mode

In constant voltage mode, the voltage of the internal high voltage DC power supply is limited and the amplitude of the input signal is limited to limit the output voltage.

Use the unit paying attention to the following:

- The limit voltage for setting is only a guideline. There is approx. 0 to 100V error for the set value.
- If the output voltage is not proportional to the input voltage due to load, the value may be larger by about 1 kV than the set value.

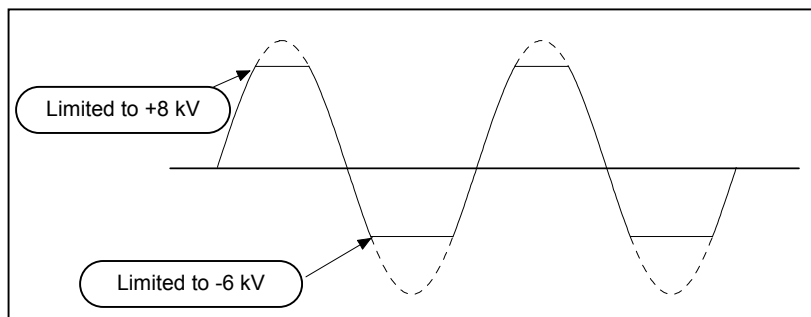

Figure3-7. Operation of voltage limiter (1)

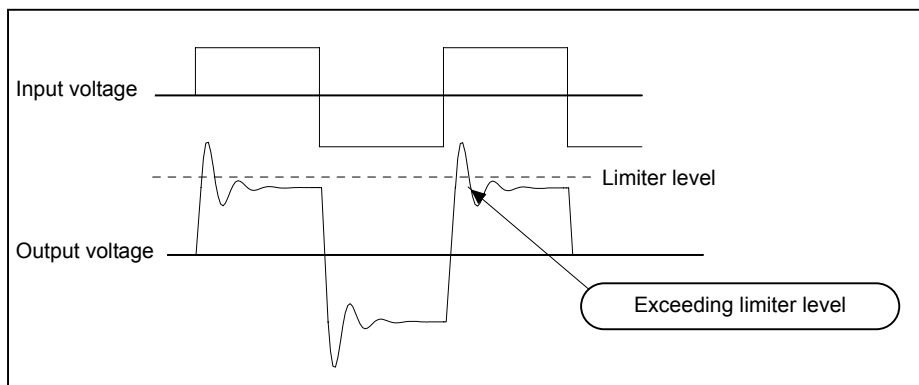

Figure3-8. Operation of voltage limiter (2)

- In constant current mode

In constant current mode, the voltage of the internal high voltage DC power supply is limited to limit the output voltage. Use the unit paying attention to the following:

- Since the limit is made by current voltage, there is approx. 0 to 1 kV error for the set value.

- DC CURRENT (mA)

The output current limit value is set. The limit value is common for both positive and negative and the average current can be set in the range from 0 mA to 10 mA.

For example, the value is set to 3 mA, the limit is +3 mA or -3 mA for DC. For AC, the average current for positive side is 3 mA and the average current for negative side is -3 mA.

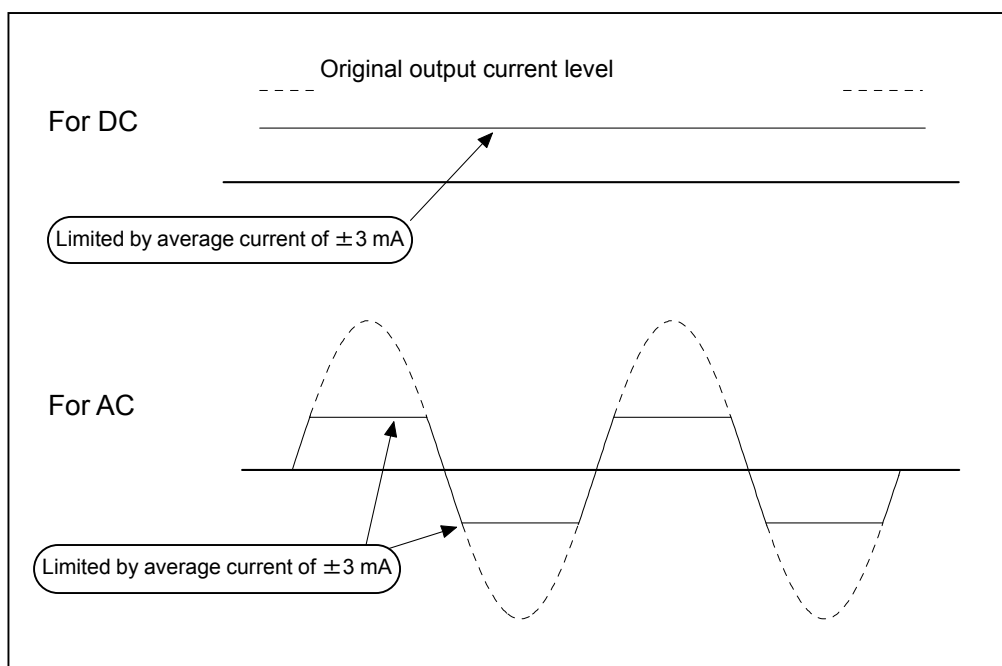

Figure3-9. Operation of current limiter

Use this current limiter paying attention to the following:

- The limit current set here is only a guideline. The setting accuracy is not high.
- It is limited not by peak current, but by average current.
- The voltage waveform of a load capacity may be non-linear due to limitation by average current, resulting in increase of peak current.

- LIMIT/TRIP

In LIMIT, the output current is limited with the setting value.

In TRIP, if the output current exceeds the set value, SIGNAL is switched OFF and the output is 0V.

3.2 Amplifier

■ RESPONSE CV

In constant voltage mode, the step response waveform such as square wave is adjusted. As the dial is turned toward the right, the response approaches the peak. Make adjustment for the desired response waveform.

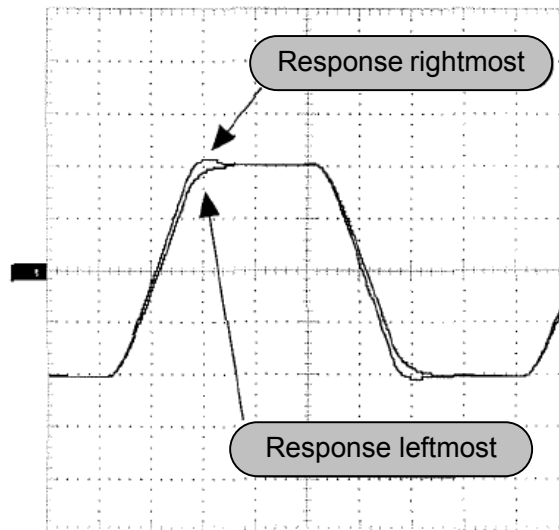

Figure3-10. Response function in constant voltage mode

■ RESPONSE CC

In constant current mode, the step response waveform such as square wave is adjusted. As the dial is turned toward the right, the response approaches the peak. Make adjustment for the desired response waveform.

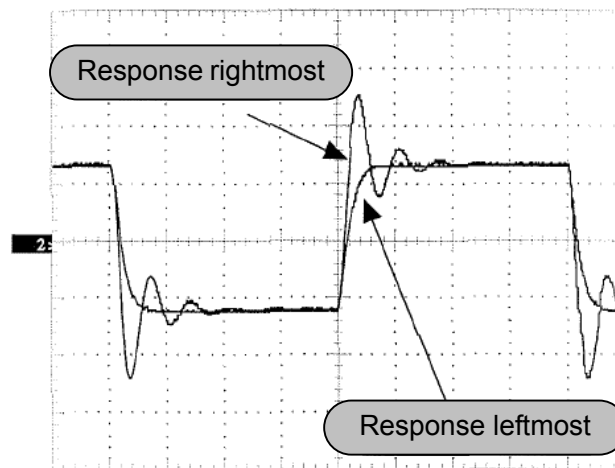

Figure3-11. Response function in constant current mode

⚠ CAUTION

The step response using RESPONSE may not be sufficiently adjusted depending on setting conditions or load conditions. In a case, oscillation may occur.

3.2.3 Output

■ HIGH VOLTAGE POWER SUPPLY ON/OFF

Turn ON/OFF the internal high voltage DC power supply.

Press the switch until it "clicks". It is then locked and the internal high voltage DC power supplies is OFF.

To turn it ON, turn the knob to the right. It is unlocked and the internal high voltage DC power supply is ON.

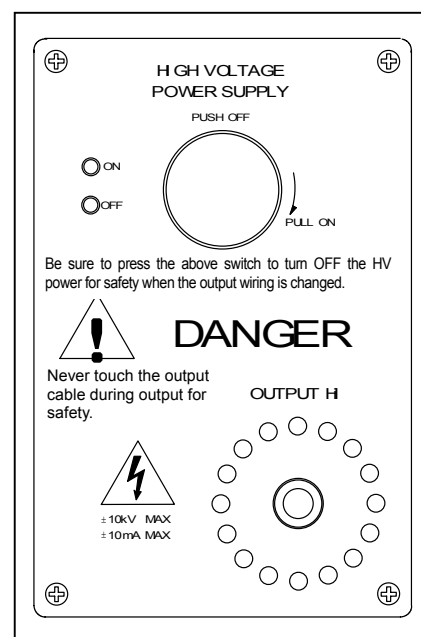

Figure3-12. Output area

⚠ WARNING

When wiring for load or output is changed, be sure to turn OFF (push) this switch. Make sure that the OFF lamp at the left of the switch lights before work.

Do not touch load or the output cable with the internal high voltage DC power supply ON. Otherwise, electric shock may occur.

When the power is supplied, the internal high voltage DC power supply is always OFF regardless of ON/OFF status of this switch. If this switch is ON, turn it OFF once and turn it ON again.

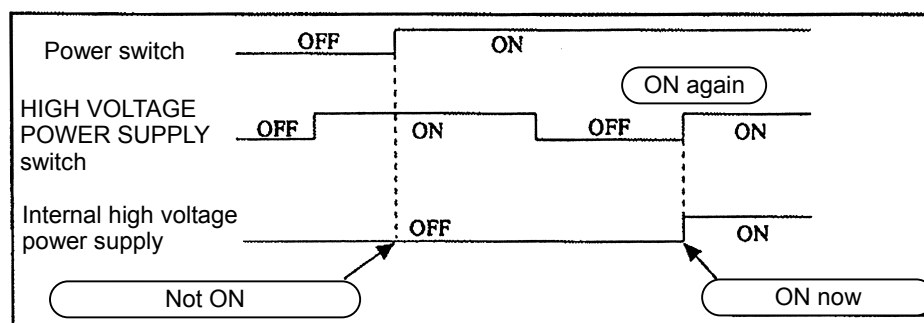

Figure3-13. Power supply and internal high voltage DC power

3.2 Amplifier

■ ON/OFF

Indicates the output status of the internal high voltage DC power supply. When the high voltage DC power supply gives high voltage output, the ON LED lights.

■ OUTPUT HI

It is the high voltage output terminal of the unit. Connect the accompanying special cable for use.

■ Output display warning lamp

When high voltage output is given, the LED around OUTPUT HI rotates and lights. The color is yellow up to about 4.9 kV and red over this value. The rotation speed varies depending on the output voltage level. The higher the voltage is, the faster the rotation speed is.

■ OUTPUT Lo TOTAL CURRENT

It is the return terminal of the high voltage output used in constant voltage mode or constant current total mode.

■ OUTPUT Lo LOAD CURRENT

It is the return terminal of the high voltage output used in constant current load mode.

■ CURRENT SELECT

Total/load mode is set. When the unit is used in total mode, set it to TOTAL. When it is used in load mode, set it to LOAD.

For details, refer to "4.2 Operation example in constant current mode (total)" and "4.3 Operation example in constant current mode (load)".

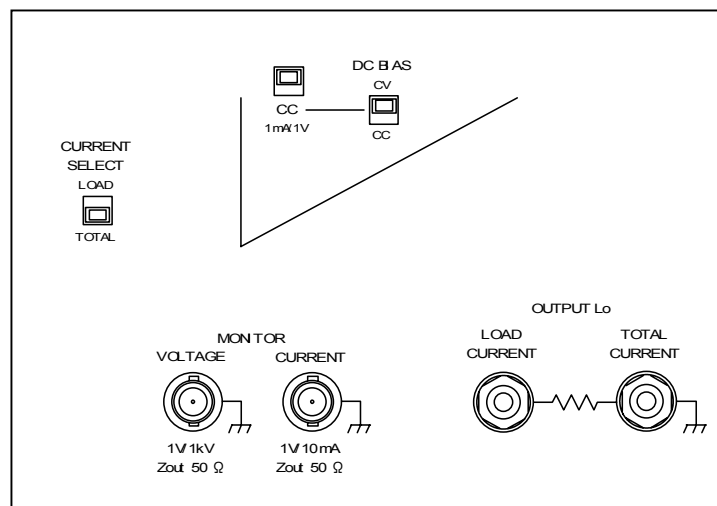

Figure3-14. Return terminal

3.3 Monitor and control signal system

3.3.1 Monitor

■ MONITOR VOLTAGE

It is the BNC connector for the monitor signal of output voltage.

- Gain: 1V/1kV
- Output impedance: $50\ \Omega \pm 10\%$

■ MONITOR CURRENT

It is the BNC connector for the monitor signal of output current. In constant current mode, current selected by TOTAL/LOAD is monitored.

- Gain: 1V/10 mA
- Output impedance: $50\ \Omega \pm 10\%$

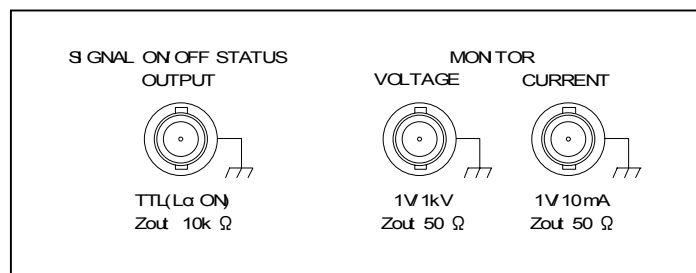

Figure3-15. Monitor output

■ SIGNAL ON/OFF STATUS

It is the total level signal output that indicates SIGNAL ON/OFF status. When the signal is ON, the level is low (approx. 0.1V or less). When the signal is OFF, the level is high (approx. 4.5V or more).

1/ Signal switch

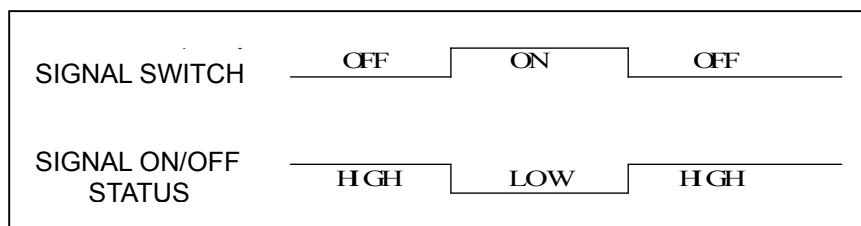

Figure3-16. Status signal output

3.3.2 Control signal system

■ ON/OFF CONTROL

It is the remote/local setting switch. In LOCAL, the unit can be turned ON/OFF with the panel switch. In REMOTE, the unit can be turned ON/OFF with an external signal. In REMOTE, the operation of HIGH VOLTAGE POWER SUPPLY ON/OFF can be made with the panel.

HIGH VOLTAGE POWER SUPPLY ON/OFF	Internal DC high voltage ON/OFF
SIGNAL ON/OFF	High voltage amplifier input ON/OFF
OSC INPUT ON/OFF	External oscillator signal ON/OFF
INT DC BIAS ON/OFF	Internal DC bias signal ON/OFF
EXT DC BIAS ON/OFF	External DC bias signal ON/OFF

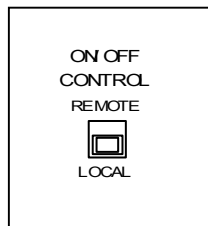

Figure3-17. Remote/local settings

Change REMOTE/LOCAL when the signal is OFF. If REMOTE/LOCAL is changed with the signal ON, the signal is forcibly turned OFF.

■ REMOTE CONTROL INPUT

It is the BNC connector to give ON/OFF control signal input when ON/OFF CONTROL is set to REMOTE.

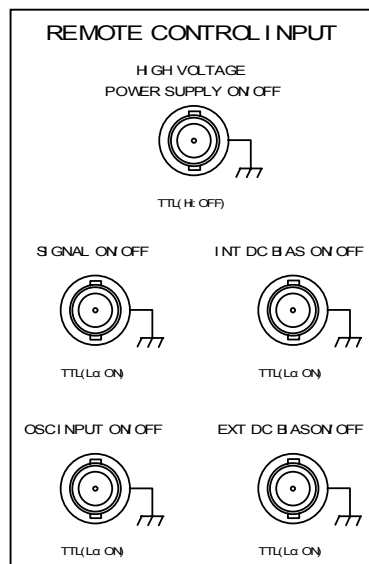

Figure3-18. Remote control input

The delay time from input of the SIGNAL ON/OFF signal to actual ON/OFF is approximately $5 \mu\text{s}$ or less. The delay time from input of other ON/OFF signals to actual ON/OFF is approximately $15 \mu\text{s}$ or less.

The input circuit of the remote control terminal is as follows:

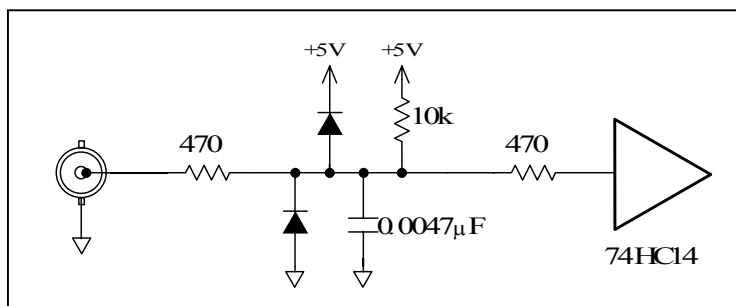

Figure3-19. Remote control input circuit

■ HIGH VOLTAGE POWER SUPPLY ON/OFF

HIGH VOLTAGE POWER SUPPLY ON/OFF controls ON/OFF of the internal DC high voltage power supply.

When the HIGH VOLTAGE POWER SUPPLY ON/OFF switch on the front panel is ON and the HIGH VOLTAGE POWER SUPPLY ON/OFF signal on the back panel is ON, the internal high voltage DC power supply is ON.

Table3-1. Logic of HIGH VOLTAGE POWER SUPPLY ON/OFF

HIGH VOLTAGE POWER SUPPLY ON/OFF signal in remote control operation					
Front panel switch		OFF		ON	
Back panel control signal	TTL	High (Approx. 5 V)	Low (Approx. 0V)	High (Approx. 5 V)	Low (Approx. 0 V)
	Contact	Open	Close	Open	Close
Status of internal high voltage DC power supply		OFF			ON

For HIGH VOLTAGE POWER SUPPLY ON/OFF, the control with external signal is always effective regardless of "REMOTE" or "LOCAL" settings on the front panel switch.

Therefore, when external control is not used, be sure to short-circuit the control input terminal at the back with an accompanying shorting plug.

If shorting is not performed, the internal high voltage DC power supply is not ON although HIGH VOLTAGE POWER SUPPLY ON/OFF switch on the panel is "ON".

3.3 Monitor and control signal system

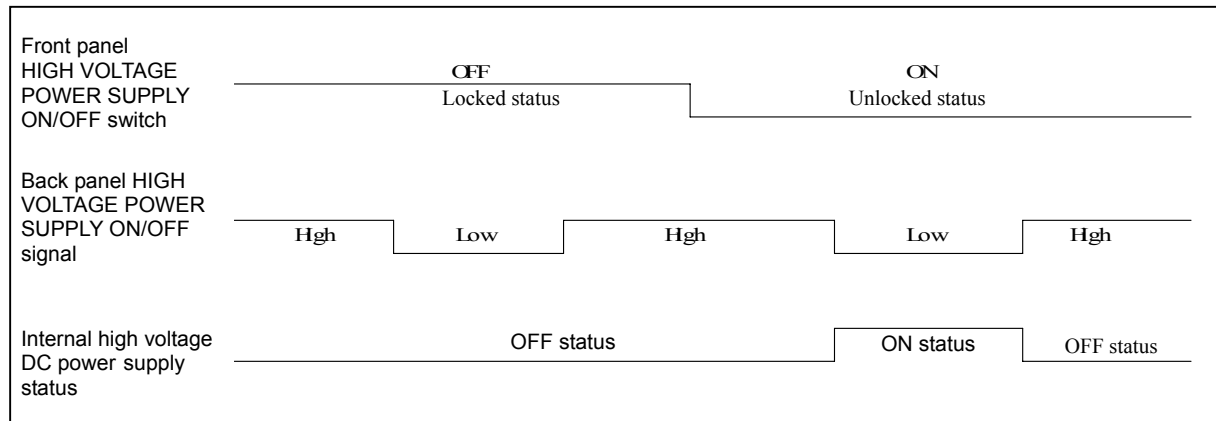

Figure3-20. Remote control of HIGH VOLTAGE POWER SUPPLY ON/OFF

■ ON/OFF of signal system

Each signal of INT DC BIAS ON/OFF, EXT DC BIAS ON/OFF and OSC INPUT ON/OFF can be individually controlled for ON/OFF. To give a signal output from the output terminal, both the desired signal ON/OFF and SIGNAL ON/OFF must be ON.

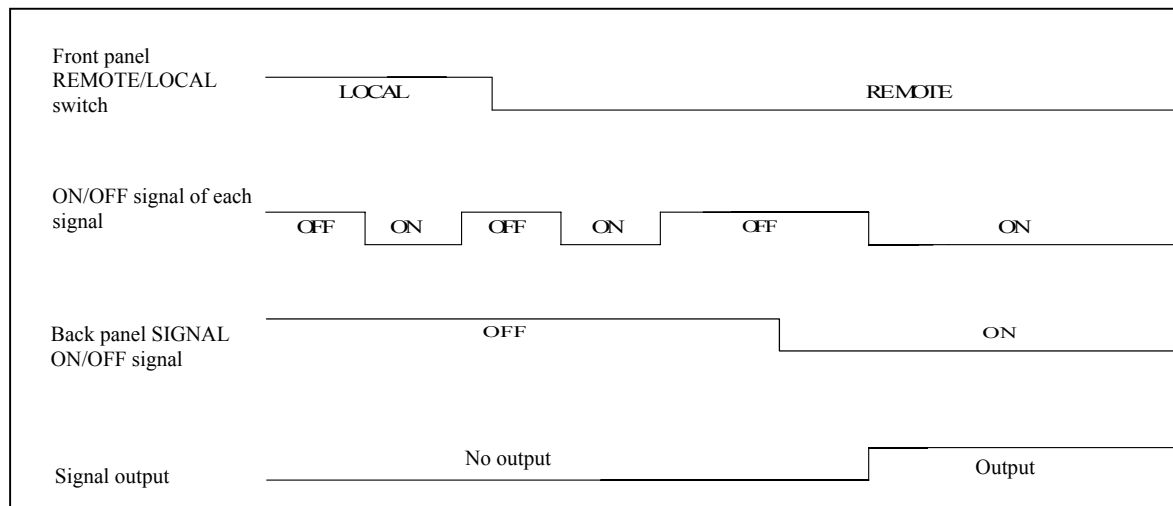

Figure3-21. Remote control of signal system ON/OFF

Table3-2. Logic of signal system ON/OFF signal

ON/OFF signal of signal system in remote control operation			
Back panel control signal	TTL	High(Approx. 5V)	Low(Approx. 0V)
	Contact	Open	Close
Signal status		OFF	ON

■ SIGNAL ON/OFF

SIGNAL ON/OFF controls a batch ON/OFF operation for input signals with external signal.

When SIGNAL is ON and ON becomes OFF for some reason, turn the control signal OFF once and turn it ON again. Otherwise, SIGNAL is not ON.

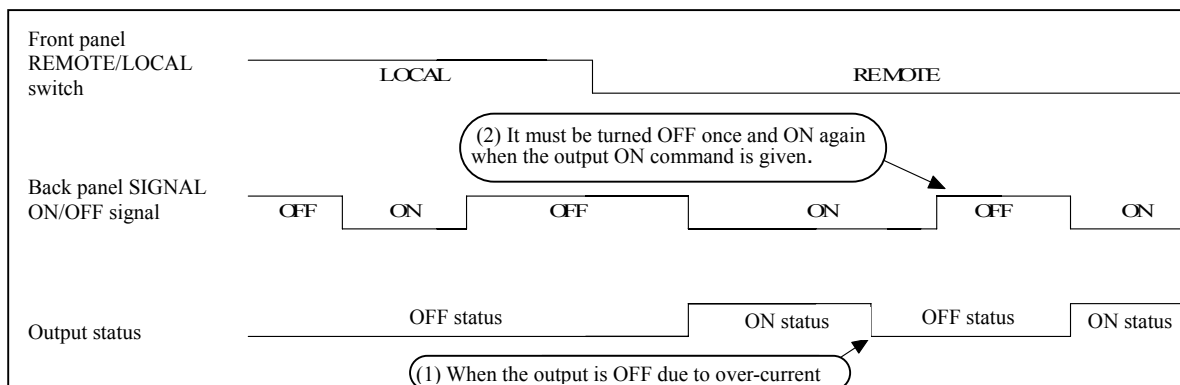

Figure3-22. Remote control of signal ON/OFF

Table3-3. Logic of SIGNAL ON/OFF signal

SIGNAL ON/OFF signal in remote control operation			
Back panel control signal	TTL	High(Positive logic)	Low(Positive logic)
		Contact	Open
Signal status		OFF	ON

3.3 Monitor and control signal system

■ SIGNAL ON/OFF STATUS

It is the terminal to give contact signal output linked to SIGNAL ON/OFF status.

Table3-4. Status contact output signal

Terminal signal	Signal name	Explanation
--	-----	Terminal for fixing. Do not use it.
2	Not connected	Not connected to any line. It can used as a relay terminal.
3	COM	Common terminal for contact output.
4	NC	When SIGNAL is OFF, it is connected to the COM terminal.
5	NO	When SIGNAL is ON, it is connected to the COM terminal.
--	-----	Terminal for fixing. Do not use it.

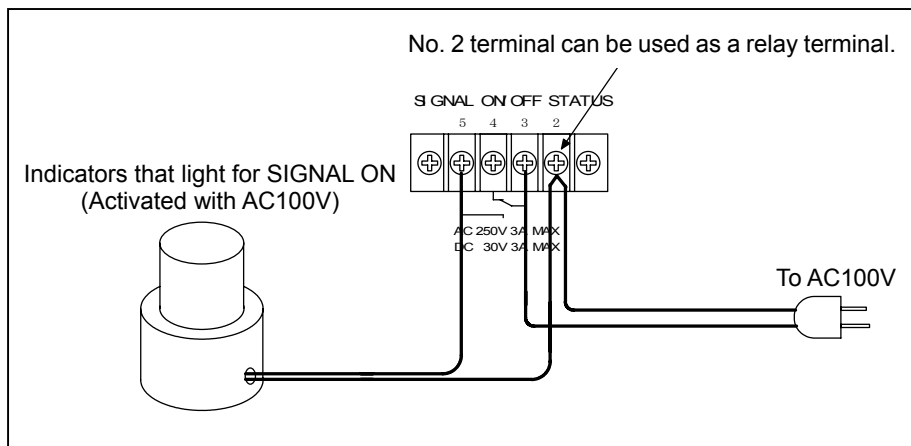

Figure3-23. Example of status contact output

3.4 Power supply items

- POWER

It is the power switch of the unit.

- LINE

It is connected to single phase AC100V.

Be sure to connect it to the outlet with ground with an accompanying 3 pin power cable.

- 

It is terminal for grounding of casing. If grounding is not available with a power cable, ground this terminal with a wire of 2 mm² or more.

 **WARNING**

Be sure to ground this unit for safety. Otherwise, a serious accident such as electric shock may occur.

- FUSE

Use a 10A/250V fuse with time lag.

 **WARNING**

When a fuse is replaced, be sure to disconnect the power cable from the outlet. Replace it with the same standard one.

For this product, the time lag type fuse with the rating of 10A/250V and $\phi 2 \times 20$ mm is used.

3.5 Nomenclature

3.5.1 Front panel

Page number of detailed explanation is shown after .

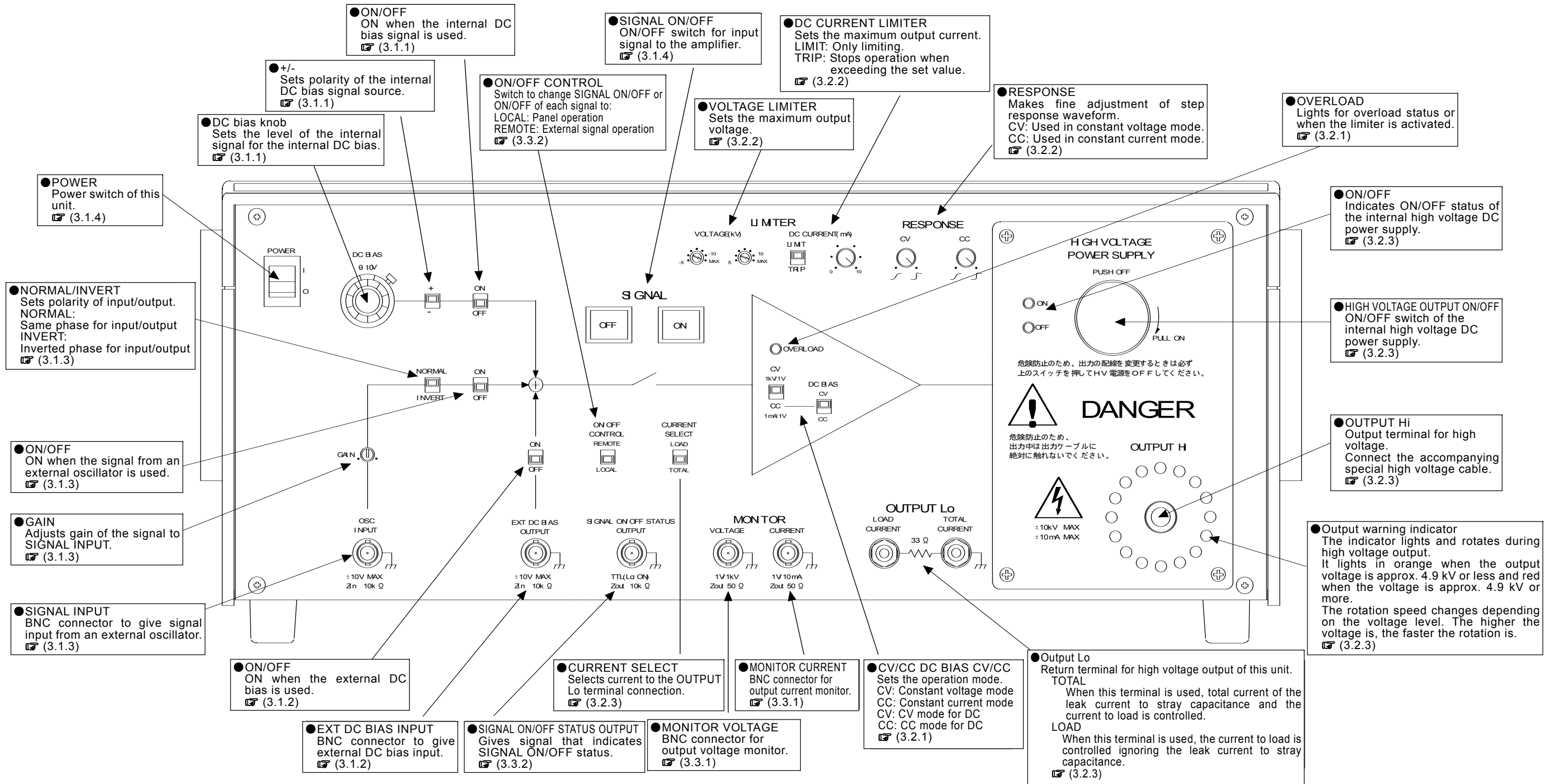

3.5.2 Rear panel

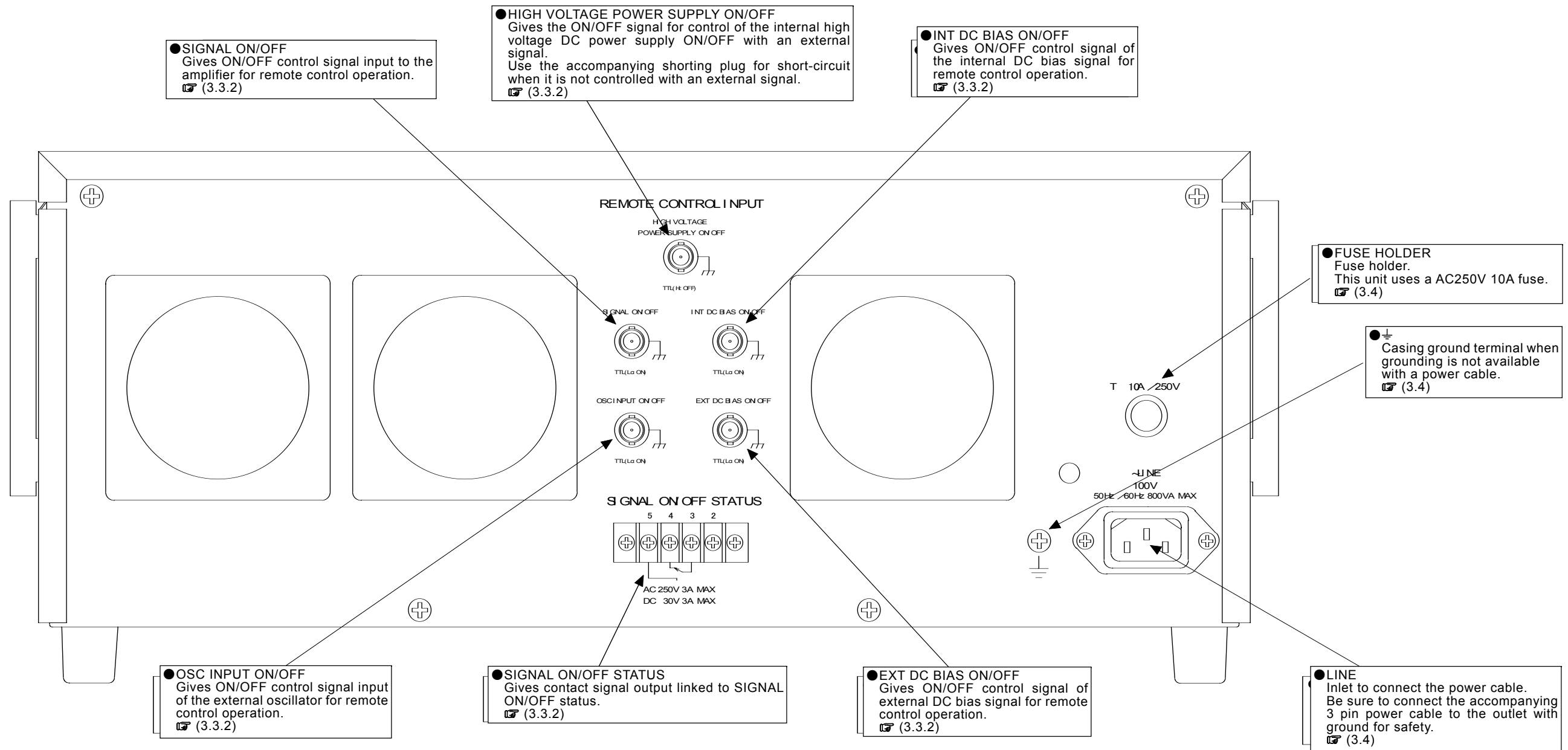

4. Operation method

4.1	Operation example in constant voltage mode	4-1
4.1.1	Panel setting	4-3
4.1.2	Connection of signal source and connection of load	4-6
4.1.3	Power supply and internal high voltage DC power supply	4-9
4.1.4	Signal output and adjustment	4-11
4.1.5	Signal OFF	4-13
4.2	Operation example in constant current mode (total)	4-14
4.2.1	Panel setting	4-16
4.2.2	Connection of signal source and connection of load	4-19
4.2.3	Power supply and internal high voltage DC power supply	4-22
4.2.4	Signal output and adjustment	4-24
4.2.5	Signal OFF	4-26
4.3	Operation example in constant current mode (load)	4-27
4.3.1	Panel setting	4-29
4.3.2	Connection of signal source and connection of load	4-32
4.3.3	Power supply and internal high voltage DC power supply	4-35
4.3.4	Signal output and adjustment	4-37
4.3.5	Signal OFF	4-39
4.4	Operation example in constant current + constant voltage mode	4-40
4.4.1	Panel setting	4-42
4.4.2	Connection of signal source and connection of load	4-45
4.4.3	Power supply and internal high voltage DC power supply	4-48
4.4.4	Signal output and adjustment	4-50
4.4.5	Signal OFF	4-52
4.5	Change of load and power OFF	4-53
4.5.1	Change of load	4-53
4.5.2	Power supply OFF	4-56
4.6	Remote control	4-57
4.6.1	Remote control	4-57
4.6.2	Panel setting for use of remote control	4-58

4.1 Operation example in constant voltage mode

This section describes operation example for use of this unit in constant voltage mode. In constant voltage mode, the output voltage changes according to the input signal.

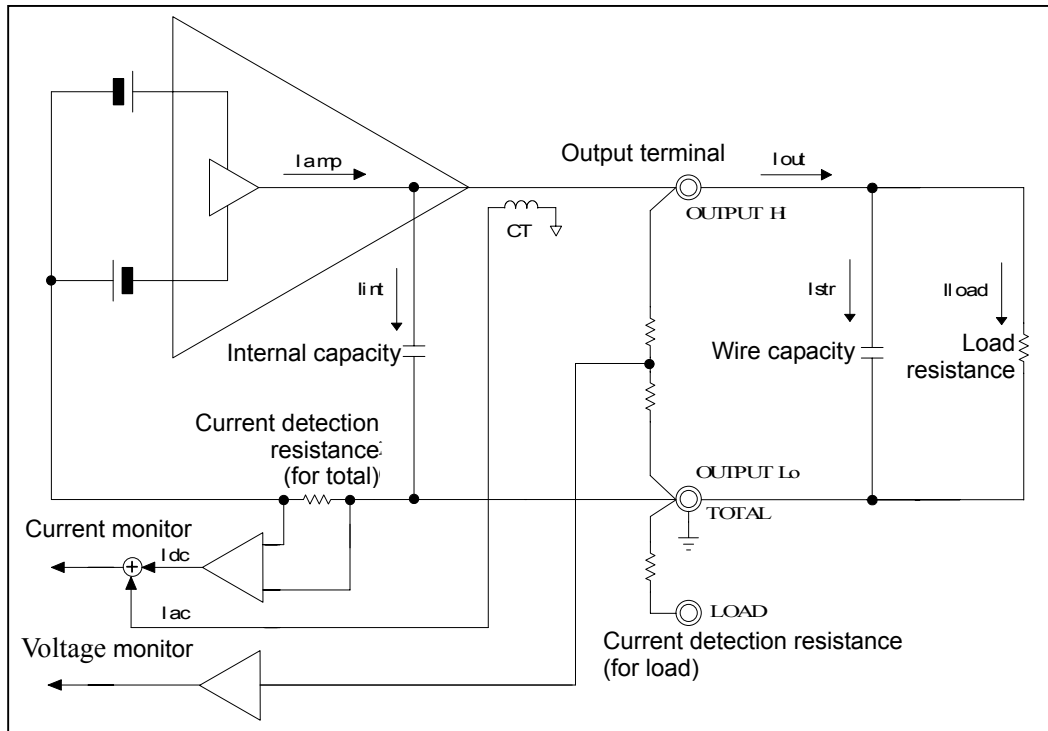

Figure4-1. Constant voltage mode (total mode)

- I_{amp} :Output current of high voltage amplifier
- I_{int} :Leak current with internal capacity
- I_{out} :Output current
- I_{str} :Leak current with wire capacity
- I_{load} :Load current
- I_{ac}, I_{dc} :DC and AC of detected current

In total mode, from output current I_{out} , DC is detected with current detection resistance and AC is detected with current transformer CT. Total output of leak current I_{str} with wire capacity and load current I_{load} is given to the current monitor.

(Leak current I_{int} (AC) with stray capacity in the amplifier runs through the current detection resistance, but only DC is detected here. The monitor is hardly affected.)

⚠ CAUTION

Effect of stray capacitance of the cable is found only for AC signal output. Effect of stray signal is not found for DC signal. Therefore, use the DC signal in total mode.

4.1 Operation example in constant voltage mode

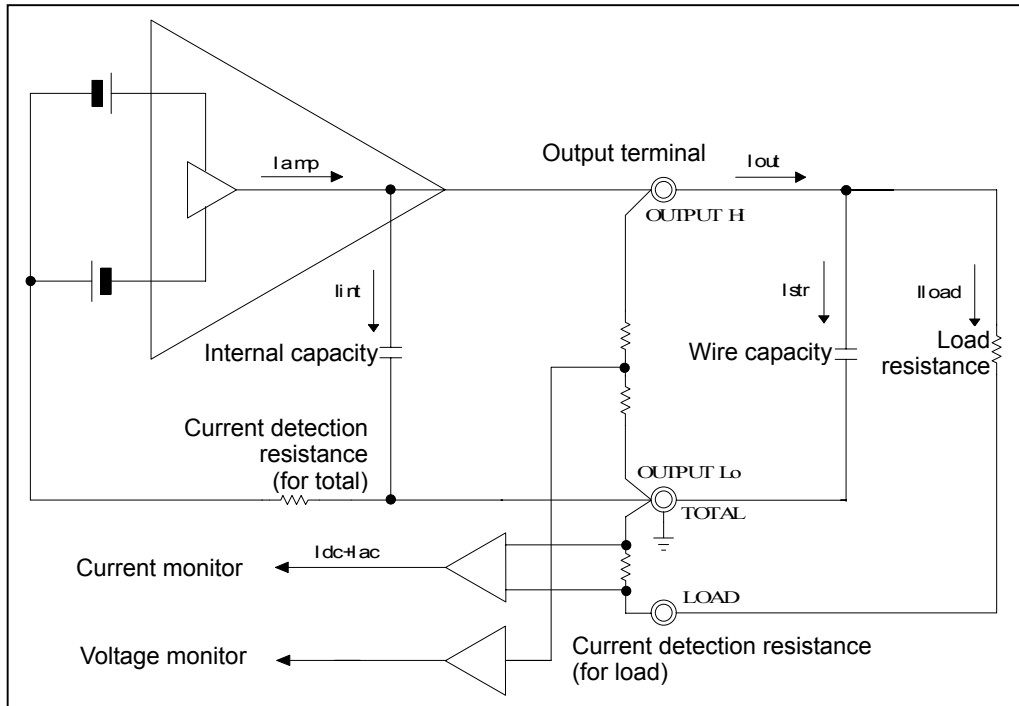

Figure4-2. Constant voltage mode (load mode)

- I_{amp} : Output current of high voltage amplifier
- I_{int} : Leak current with internal capacity
- I_{out} : Output current
- I_{str} : Leak current with wire capacity
- I_{load} : Load current
- I_{ac}, I_{dc} : DC and AC of detected current

In load mode, only load current is directly detected. The current monitor can monitor load current only.

In load mode of constant voltage mode:

○ Advantage

- Only load current can be monitored.

○ Disadvantage

- One end of load cannot be directly grounded. There is a current detection resistance ($33\ \Omega$) between load end and ground.
- The voltage of output current \times current detection resistance ($33\ \Omega$) for set output voltage is an error in load. (When the load current is 10 mA, the error is 330 mV.)

4.1.1 Panel setting

a) Internal high voltage DC power OFF

When the HIGH VOLTAGE POWER SUPPLY switch is not OFF, press the button until a "click" sound is heard. When a click sound is heard, the switch is locked in OFF status. The internal high voltage DC power supply is always OFF.

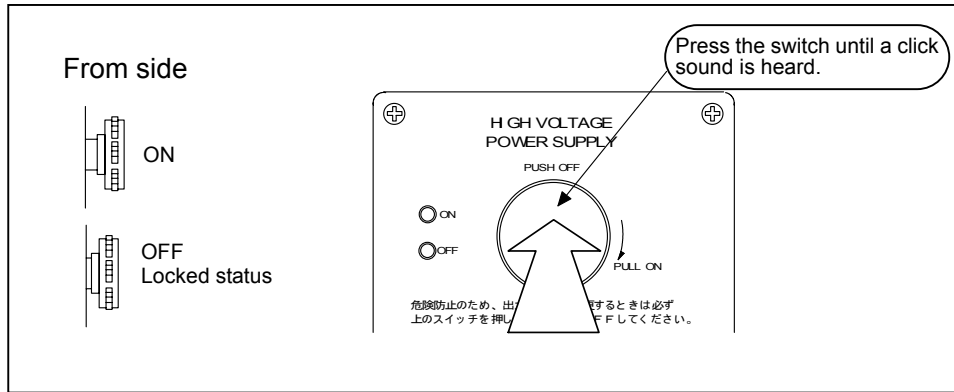

Figure4-3. Internal high voltage DC power OFF

b) Signal system OFF

Turn the internal DC bias knob to the leftmost position to minimize the value. Turn OFF the switches of DC BIAS, OSC INPUT and EXT DC BIAS INPUT.

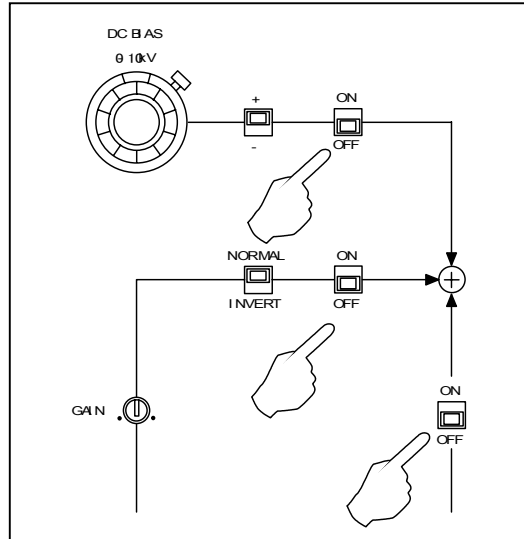

Figure4-4. Switch settings

4.1 Operation example in constant voltage mode

c) Output mode settings

Set the output mode switch to CV. In constant voltage mode, the DC bias setting is invalid.

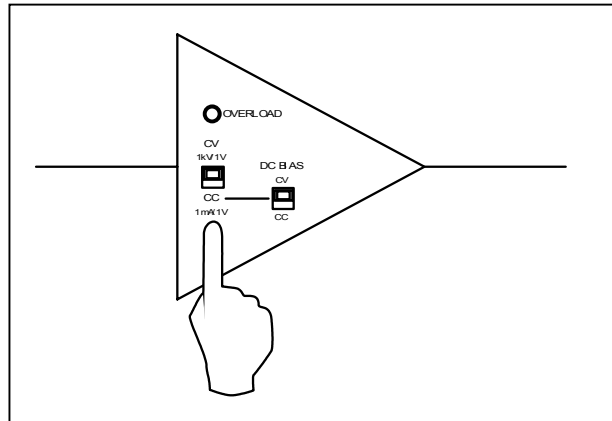

Figure4-5. Output mode settings

d) Remote/local settings

To operate this unit from the panel, set the ON/OFF CONTROL switch to LOCAL. Refer to "4.6 Remote control operation" for remote control operation.

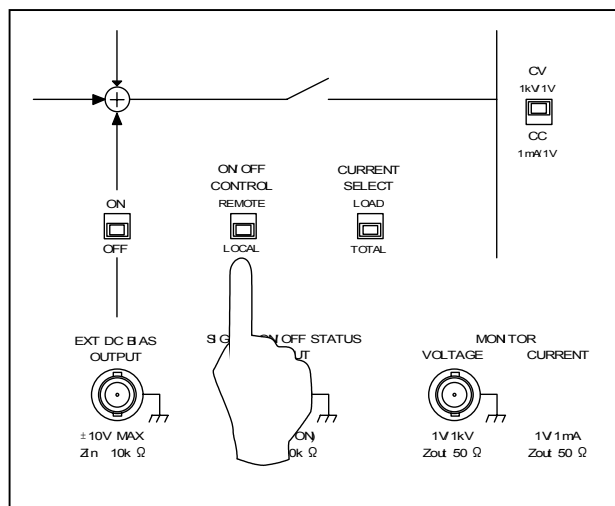

Figure4-6. Local settings

e) Output limiter settings

To limit the output voltage and output current, set the limiter level as required.

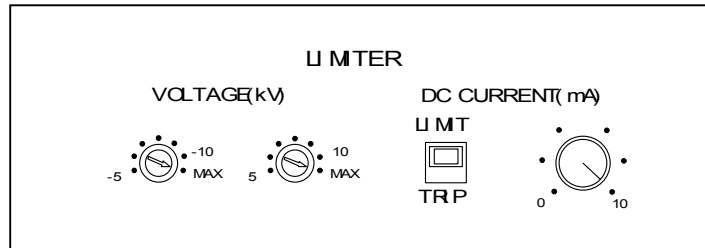

Figure4-7. Limiter settings

■ Voltage limiter

The voltage limiter function can limit the maximum value of the output voltage independently for positive and negative values in the range from ± 5 kV to ± 10 kV. For example, the output is sufficient up to ± 8 kV, set the VOLTAGE LIMITER to 8 kV and -8 kV.

When voltage limitation is not required, set it to MAX.

■ Current limiter

The current limiter function can limit the average value of the output current in the range from 0 mA to ± 10 mA. For example, to limit the output current up to 5 mA, set it to 5 mA.

When current limitation is not required, set it to 10 mA which is turned to the rightmost position.

■ LIMIT/TRIP

Set the protection mode for activation of the current limiter. When LIMIT is selected, current is limited to the set current. When TRIP is selected, the input signal is immediately OFF for activation of the current limiter circuit and the output is 0V.

Select either one as required.

f) Current monitor mode settings

In total mode, set it to TOTAL CURRENT and in load mode, set it to LOAD CURRENT.

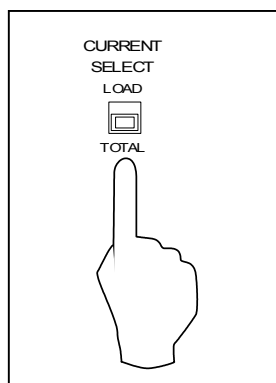

Figure4-8. Current monitor mode settings

4.1 Operation example in constant voltage mode

g) RESPONSE knob settings

Set the CV RESPONSE knob to TOP.

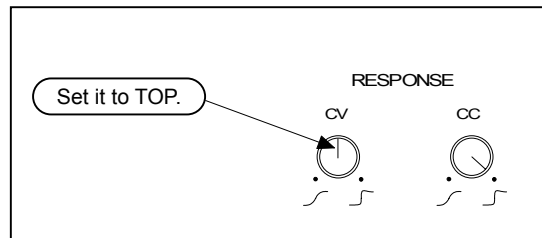

Figure4-9. Response settings

4.1.2 Connection of signal source and connection of load

a) Connection of input signal source

Give the signal generator (e.g. oscillator) output to OSC INPUT. When applying the external DC bias, give the DC signal source output to EXT DC BIAS INPUT.

The input voltage of the OSC INPUT terminal and the EXT DC BIAS INPUT terminal is maximum $\pm 10V$.

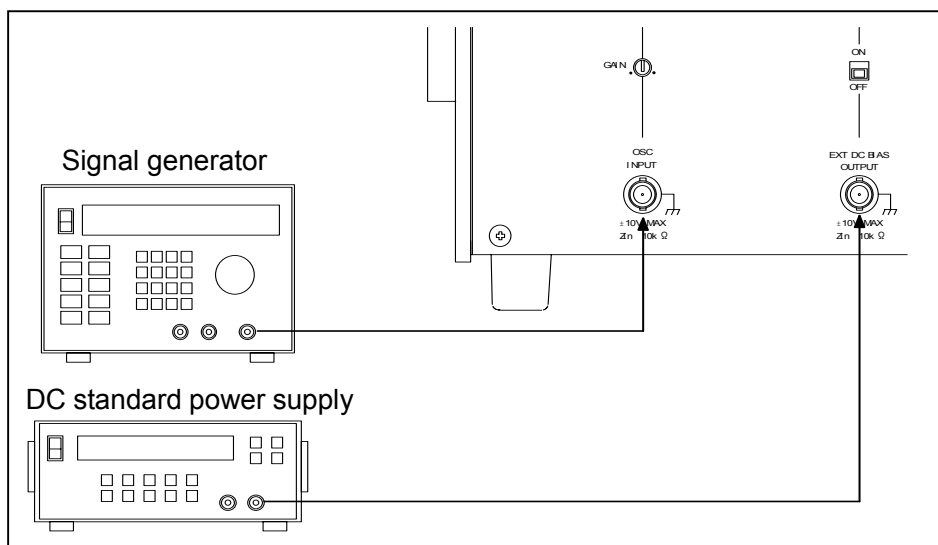

Figure4-10. Connection of external signal source signal

b) Monitor signal output

Connect a measuring instrument such as oscilloscope or voltmeter to VOLTAGE MONITOR or CURRENT MONITOR as required.

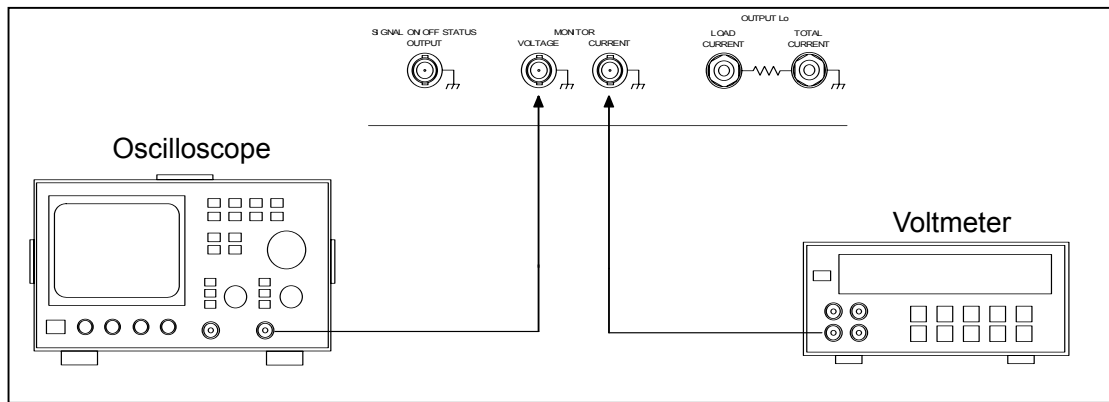

Figure4-11. Connection of monitor

c) Connection of load

Be sure to use the accompanying cable for the cable connected to Hi. To minimize effect from stray capacitance, shorten the cable length as much as possible and keep it away from the floor or other devices.

Connect the output return wire to TOTAL CURRENT terminal in total mode.

Connect it to LOAD CURRENT in load mode.

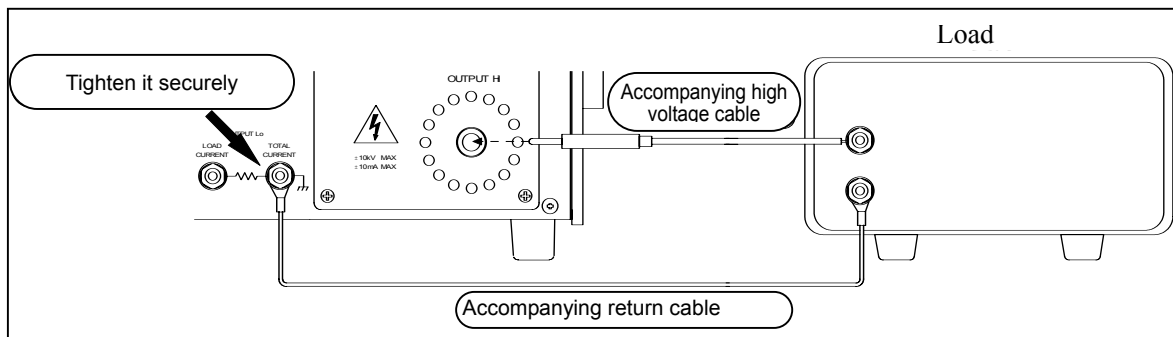

Figure4-12. Connection of output cable

4.1 Operation example in constant voltage mode

 **CAUTION**

Match the setting of the return terminal with that of the CURRENT SELECT switch. If it is different, current cannot be monitored.

The TOTAL CURRENT terminal is connected to the casing.

 **WARNING**

Tighten the binding post terminal of OUTPUT Lo securely. If it is loose, electric shock may occur when touching the load grounding or the return cable.

Check sometimes if it is not loose when the power is OFF and it is safe.

4.1.3 Power supply and internal high voltage DC power supply

a) Power supply

Before supply of power, check again if the HIGH VOLTAGE POWER SUPPLY switch is OFF (button is pressed). After checking connection to load, connection to the signal source and if the panel settings are correct, turn ON the POWER switch of the unit.

When the power is ON, the fan at the back starts operation.

On the panel surface:

- The OFF lamp of the signal switch blinks.
- The OFF LED of the internal high voltage DC power supply lights.

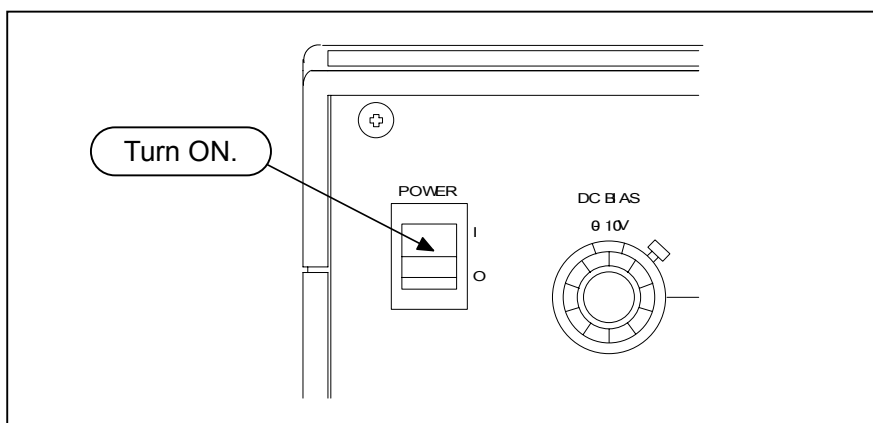

Figure4-13. Power supply

b) Supply of high voltage DC power

Turn the HIGH VOLTAGE POWER SUPPLY switch to the right and unlock it. Turn ON the internal high voltage power supply. The ON LED of the internal high voltage power supply lights. In several seconds, the SIGNAL switch OFF lamp changes from blinking to lighting.

When the power is supplied, the internal high voltage DC power supply is always OFF regardless of ON/OFF status of the HIGH VOLTAGE POWER SUPPLY switch. If this switch is ON, turn OFF once and turn it ON again.

4.1 Operation example in constant voltage mode

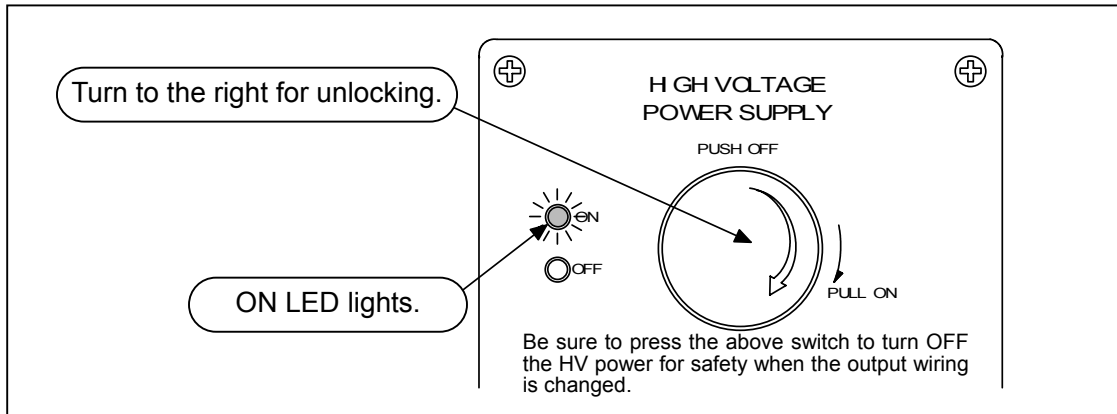

Figure4-14. Internal high voltage DC power ON

⚠ WARNING

After this operation, the internal high voltage DC power supply is ON. High voltage is generated inside the unit.

Be careful not to touch the area like an output terminal to which high voltage is applied.

- When the SIGNAL OFF switch remains blinking.

When the SIGNAL OFF switch remains blinking after unlocking the HIGH VOLTAGE POWER SUPPLY switch, check the following:

- 1) Is the shorting plug inserted into the HIGH VOLTAGE POWER SUPPLY ON/OFF terminal at the back?

Action

Insert the shorting plug for operation in LOCAL mode.

- 2) Is the DC CURRENT value the minimum and is TRIP selected?

Action

Increase the current limit or select LIMIT.

- 3) Is temperature of exhaust air extremely high?

Action

Temperature in the casing may be too high. Leave the unit at a cool environment for dozens of minutes. Then, turn ON the HIGH VOLTAGE POWER SUPPLY switch again.

- 4) Are all fans at the back operating?

Action

Check if there is any object that blocks rotation of a fan. If a fan does not rotate without any blocking, the fan may be faulty. It must be repaired.

When either of the above is not applicable, the internal high voltage DC power supply may be faulty. In this case, it must be repaired.

4.1.4 Signal output and adjustment

a) Using internal DC bias signal source

Make sure that the internal DC signal source dial is 0. Set the polarity switch to the desired polarity. Turn ON the internal DC bias signal source ON/OFF switch and press ON of the SIGNAL switch. While reading the value on the voltmeter or oscilloscope connected to the voltage monitor, turn the dial gradually to the right. Set it to the desired voltage.

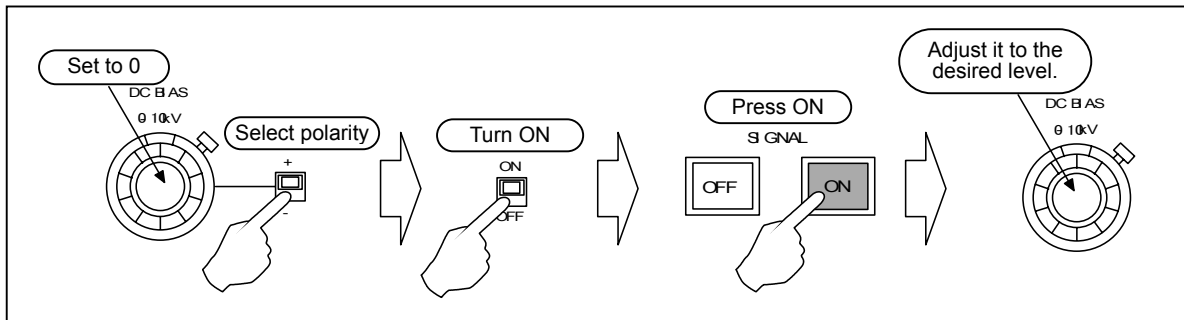

Figure4-15. Using internal DC bias signal

b) Using external oscillator

Connect the external oscillator to OSC INPUT and make sure that the oscillator output level is 0V. Set the GAIN knob to TOP. Turn ON the external oscillator ON/OFF switch and press ON of the SIGNAL switch. While reading the value on the voltmeter or oscilloscope connected to the voltage monitor, increase the output level of the oscillator gradually.

If fine adjustment of the output level is required, adjust it at the oscillator or adjust it with GAIN of the unit. Turn GAIN to the left, the gain is decreased. Turn GAIN to the right, the gain is increased. The gain can be adjusted in the range of approximately $\pm 3\%$.

4.1 Operation example in constant voltage mode

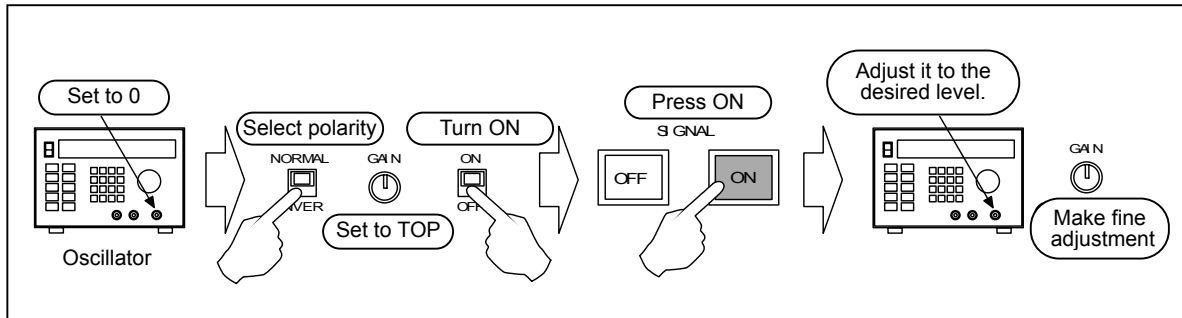

Figure4-16. Using external oscillator

c) Using external DC bias signal source

Connect the DC standard power supply to EXT DC BIAS INPUT and make sure that the output of the standard power supply is 0V. Turn ON the external DC bias ON/OFF switch and press ON of the SIGNAL switch. While reading the value on the voltmeter or oscilloscope connected to the voltage monitor, increase the output level of the DC standard power supply gradually and set the desired voltage.

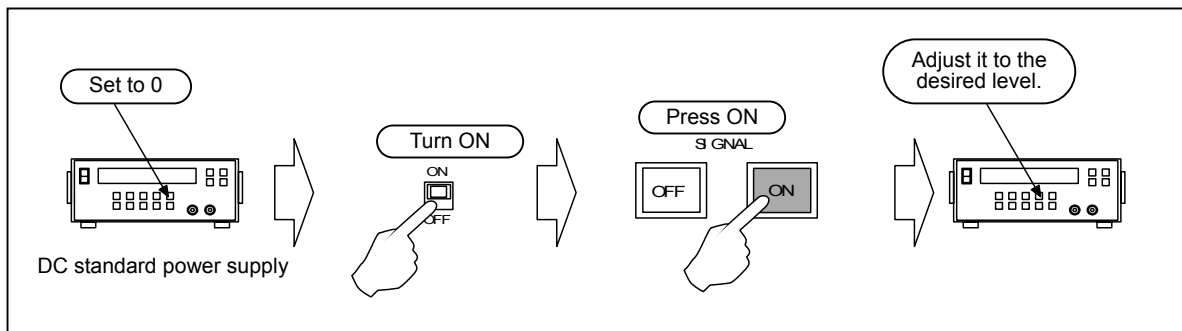

Figure4-17. Using external DC bias signal

■ High voltage display

When the output voltage exceeds $\pm 130\text{V}$ to $\pm 150\text{V}$, the high voltage output LED lights and starts rotation slowly. The higher the output voltage is, the faster the rotation is. When the voltage exceeds $\pm 4.9\text{ kV}$, the color changes from orange to red.

■ Gain adjustment with RESPONSE

The gain of 1 kHz band or more may vary depending on the RESPONSE knob position. Refer to "5.2 Characteristics in constant voltage mode, Chapter 5".

When the frequency is used at 1 kHz or more, measure the output voltage of the voltage monitor and adjust RESPONSE so that the desired amplitude may be obtained.

WARNING

It is very dangerous during output of high voltage. Never touch the output cable or the high voltage area. If you find a dangerous status due to a unit error or load error, turn OFF the POWER switch immediately.

4.1.5 Signal OFF

a) Input signal OFF

To set the output signal to 0V temporarily, press OFF of the SIGNAL switch.

WARNING

When SIGNAL is OFF, the output voltage is 0V, but the internal high voltage DC power supply is ON. It continuously gives high voltage output.

In this status, never touch the output cable or the high voltage area for safety.

b) Internal high voltage DC power supply OFF

When the HIGH VOLTAGE POWER SUPPLY switch is turned OFF, the output of the internal high voltage DC power supply is 0V and the amplifier cannot give high voltage output.

4.2 Operation example in constant current mode (total)

This section describes operation example of this unit in total mode of constant current mode.

In constant current mode, the output current varies according to the input signal. If high frequency AC signal is given at high voltage, leak current runs with stray capacitance between the cable and the ground. Therefore, not all current from the output terminal of the unit goes to load.

In total mode, current including leak current due to cable capacity is controlled.

Set current = Leak current + Load current

Effect of stray capacitance of the cable is found only for AC signal output. Effect of stray signal is not found for DC signal.

The TOTAL terminal of OUTPUT Lo is connected to the casing (= ground). Therefore, the total mode can be used for grounded load or load that can be grounded.

WARNING

When the internal high voltage DC power supply is ON and SIGNAL is ON with the output open, maximum ± 12 kV output is given to the OUTPUT Hi terminal. It is very dangerous.

Do not turn ON SIGNAL when the output is open.

In constant current mode, be sure to connect load or short-circuit the output.

When the internal high voltage DC power supply is ON and SIGNAL is OFF with the output open, ± 100 V voltage output may be given to the OUTPUT Hi terminal depending on the voltage limiter settings.

WARNING

In constant current mode, DC cannot be run for capacity load. At this time, the output for DC signal is the same as that in open status. When SIGNAL is ON, maximum ± 12 kV output is given to the OUTPUT Hi terminal.

Never apply DC to capacity load in constant current mode.

4.2 Operation example in constant current mode (total)

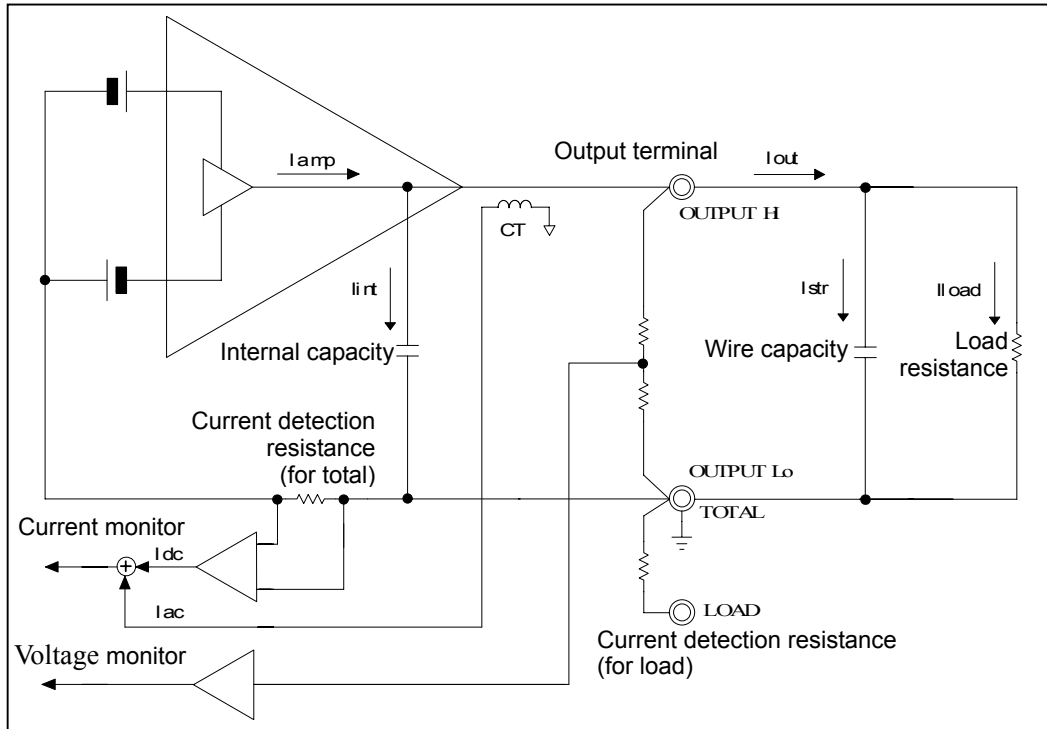

Figure4-18. Total mode

- I_{amp} : Output current of amplifier
- I_{int} : Leak current with internal capacity
- I_{out} : Output current
- I_{str} : Leak current with wire capacity
- I_{load} : Load current
- I_{ac}, I_{dc} : DC and AC of detected current

Not all current I_{out} from the output terminal is supplied to load. There is leak of I_{str} with wire capacity. Actual current to load is $I_{load} = I_{out} - I_{str}$.

In total mode, control is made to satisfy set current = $I_{out} = I_{load} + I_{str}$.

In total mode, from output current I_{out} , DC is detected with current detection resistance and AC is detected with current transformer CT. Total output of leak current I_{str} with wire capacity and load current I_{load} is given to the current monitor.

(Leak current I_{int} (AC) with stray capacity in the amplifier runs through the current detection resistance, but only DC is detected here. The monitor is hardly affected.)

4.2 Operation example in constant current mode (total)

4.2.1 Panel setting

a) Internal high voltage DC power supply OFF

When HIGH VOLTAGE POWER SUPPLY is not OFF, press the button until a "click" sound is heard. When a click sound is heard, the switch is locked in OFF status. The internal high voltage DC power supply is always OFF.

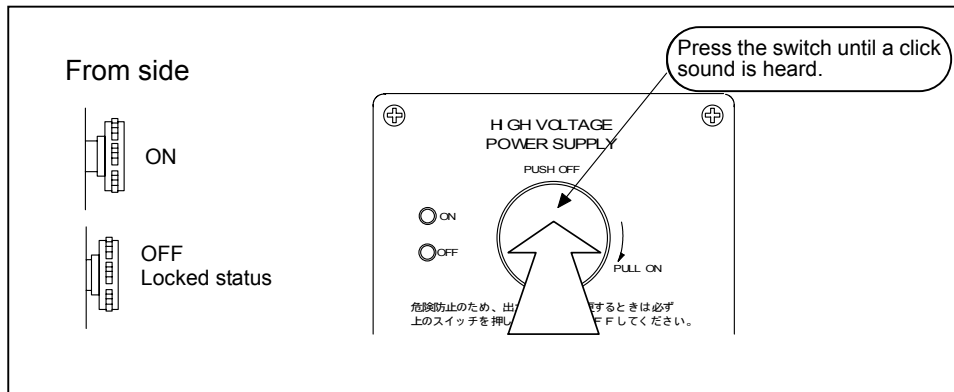

Figure4-19. Internal high voltage DC power OFF

b) Signal system OFF

Turn the internal DC bias knob to the leftmost position to minimize the value. Turn OFF the switches of DC BIAS, OSC INPUT and EXT DC BIAS INPUT.

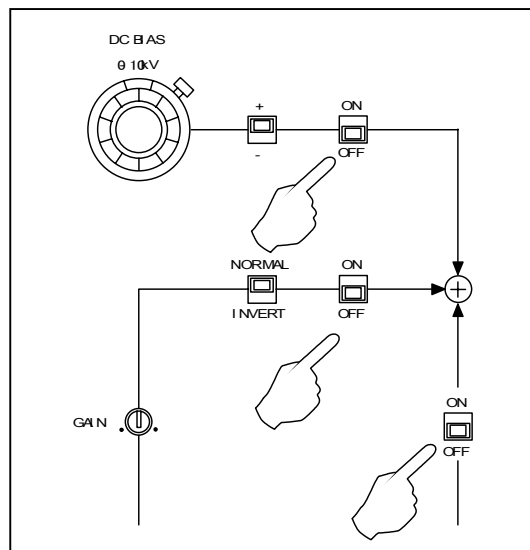

Figure4-20. Switch settings

c) Output mode settings

Set the output mode switch to CC. Set the DC BIAS to CC.

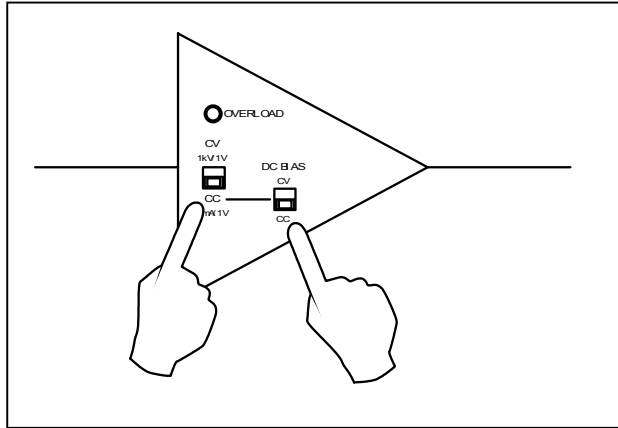

Figure4-21. Output mode settings

d) Remote/local settings

To operate this unit from the panel, set the ON/OFF CONTROL switch to LOCAL.

Refer to "4.6 Remote control operation" for remote control operation.

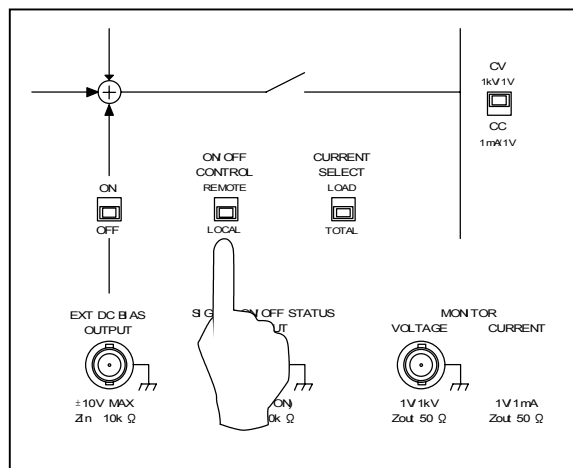

Figure4-22. Local settings

4.2 Operation example in constant current mode (total)

e) Output limiter settings

To limit the output voltage and output current, set the limiter level as required.

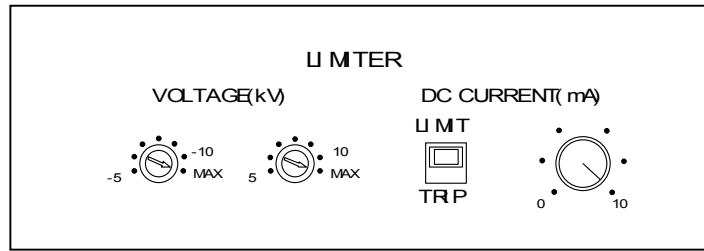

Figure4-23. Limiter settings

■ Voltage limiter

The voltage limiter function can limit the maximum value of the output voltage independently for positive and negative values in the range from ± 5 kV to ± 10 kV.

For example, the output is sufficient up to ± 8 kV, set the VOLTAGE LIMITER to 8 kV and -8 kV.

When voltage limitation is not required, set it to MAX.

■ Current limiter

The current limiter function can limit the average value of the output current in the range from 0 mA to ± 10 mA.

For example, to limit the output current up to 5 mA, set it to 5 mA.

When current limitation is not required, set it to 10 mA which is turned to the rightmost position.

■ LIMIT/TRIP

Set the protection mode for activation of the current limiter. When LIMIT is selected, current is limited to the set current. When TRIP is selected, the input signal is immediately OFF for activation of the current limiter circuit and the output is 0V.

Select either one as required.

f) Current monitor mode settings

In total mode of constant current mode, set it to TOTAL CURRENT

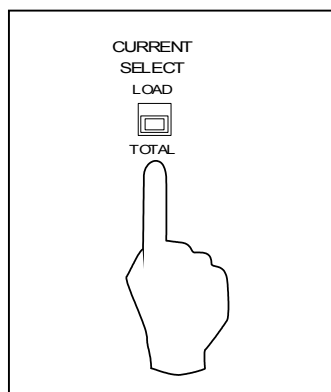

Figure4-24. Current monitor mode settings

g) RESPONSE knob settings

Set the CC RESPONSE knob to the rightmost position.

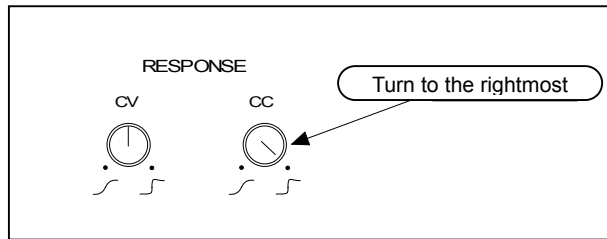

Figure4-25. Response settings

4.2.2 Connection of signal source and connection of load

a) Connection of input signal source

Give the signal generator (e.g. oscillator) output to OSC INPUT. When applying the external DC bias, give the DC signal source output to EXT DC BIAS INPUT.

The input voltage of the OSC INPUT terminal and the EXT DC BIAS INPUT terminal is maximum $\pm 10V$.

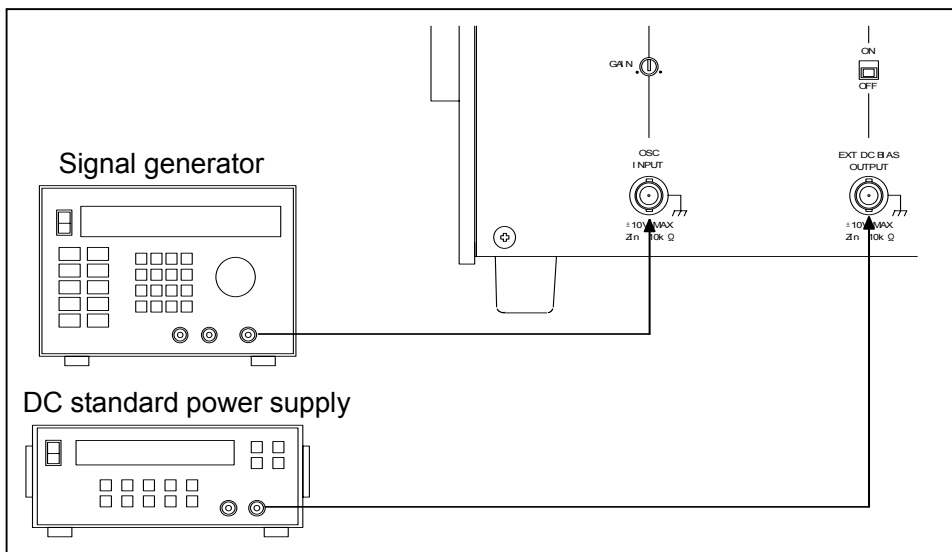

Figure4-26. Connection of external signal source signal

4.2 Operation example in constant current mode (total)

b) Monitor signal output

Connect a measuring instrument such as oscilloscope or voltmeter to VOLTAGE MONITOR or CURRENT MONITOR as required.

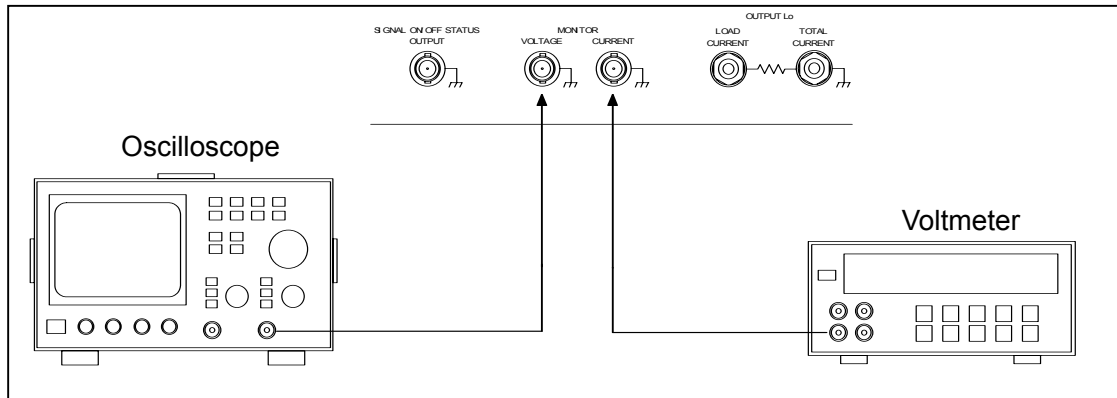

Figure4-27. Connection of monitor

c) Connection of load

Be sure to use the accompanying cable for the cable connected to Hi.

To minimize effect from stray capacitance, shorten the cable length as much as possible and keep it away from the floor or other devices.

Connect the return wire to the TOTAL CURRENT terminal.

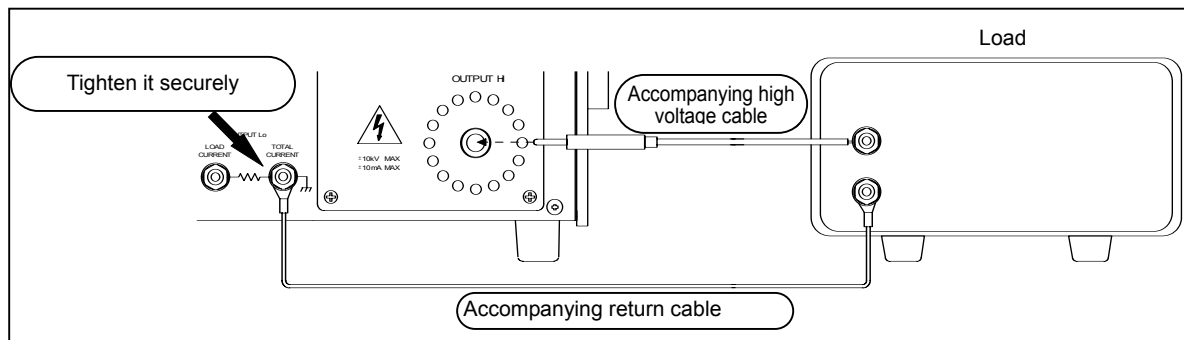

Figure4-28. Connection of output cable

 **CAUTION**

In total mode, be sure to use the TOTAL CURRENT terminal. If the LOAD CURRENT terminal is used, the operation may be faulty.

The TOTAL CURRENT terminal is connected to the casing.

 **WARNING**

Tighten the binding post terminal of OUTPUT Lo securely. If it is loose, electric shock may occur when touching the load grounding or the return cable.

Check sometimes if it is not loose when it is safe with the power OFF.

4.2.3 Power supply and internal high voltage DC power supply

a) Power supply

Before supply of power, check again if the HIGH VOLTAGE POWER SUPPLY switch is OFF (button is pressed). After checking connection to load, connection to the signal source and if the panel settings are correct, turn ON the POWER switch of the unit.

When the power is ON, the fan at the back starts operation.

On the panel surface:

- The OFF lamp of the signal switch blinks.
- The OFF LED of the internal high voltage DC power supply lights.

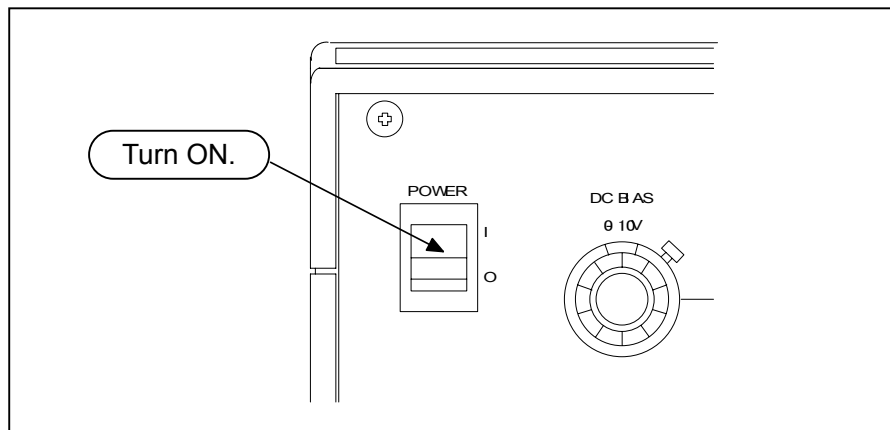

Figure4-29. Power supply

b) Supply of high voltage DC power

Turn the HIGH VOLTAGE POWER SUPPLY switch to the right and unlock it. Turn ON the internal high voltage power supply. The ON LED of the internal high voltage power supply lights. In several seconds, the SIGNAL switch OFF lamp changes from blinking to lighting.

When the power is supplied, the internal high voltage DC power supply is always OFF regardless of ON/OFF status of the HIGH VOLTAGE POWER SUPPLY switch. If this switch is ON, turn OFF once and turn it ON again.

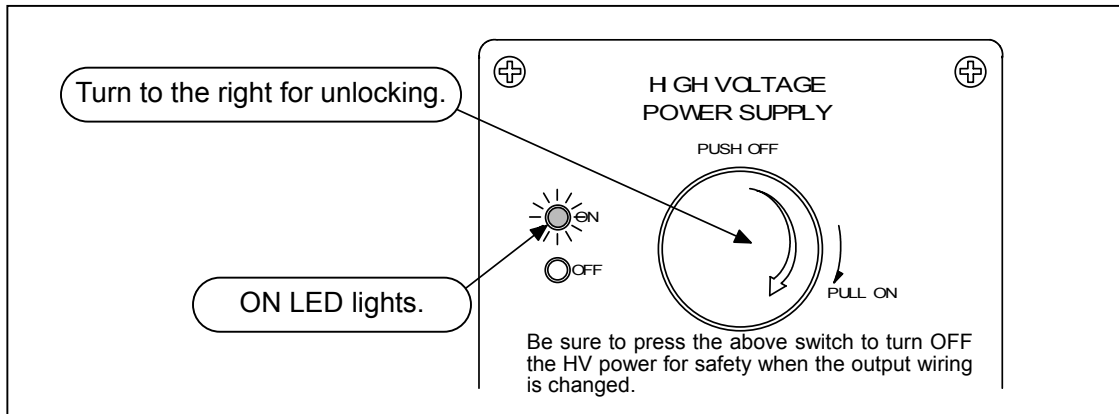

Figure4-30. Internal high voltage DC power ON

⚠ WARNING

After this operation, the internal high voltage DC power supply is ON. High voltage is generated inside the unit.

Be careful not to touch the area like an output terminal to which high voltage is applied.

○ When the SIGNAL OFF switch remains blinking.

When the SIGNAL OFF switch remains blinking after unlocking the HIGH VOLTAGE POWER SUPPLY switch, check the following:

1) Is the shorting plug inserted into the HIGH VOLTAGE POWER SUPPLY ON/OFF terminal at the back?

Action

Insert the shorting plug for operation in LOCAL mode.

2) Is the DC CURRENT value the minimum and is TRIP selected?

Action

Increase the current limit or select LIMIT.

3) Is temperature of exhaust air extremely high?

Action

Temperature in the casing may be too high. Leave the unit at a cool environment for dozens of minutes. Then, turn ON the HIGH VOLTAGE POWER SUPPLY switch again.

4) Are all fans at the back operating?

Action

Check if there is any object that blocks rotation of a fan. If a fan does not rotate without any blocking, the fan may be faulty. It must be repaired.

4.2 Operation example in constant current mode (total)

When either of the above is not applicable, the internal high voltage DC power supply may be faulty. In this case, it must be repaired.

4.2.4 Signal output and adjustment

a) Using internal DC bias signal source

Make sure that the internal DC signal source dial is 0. Set the polarity switch to the desired polarity. Turn ON the internal DC bias signal source ON/OFF switch and press ON of the SIGNAL switch. While reading the value on the voltmeter or oscilloscope connected to the voltage monitor, turn the dial gradually to the right. Set it to the desired voltage.

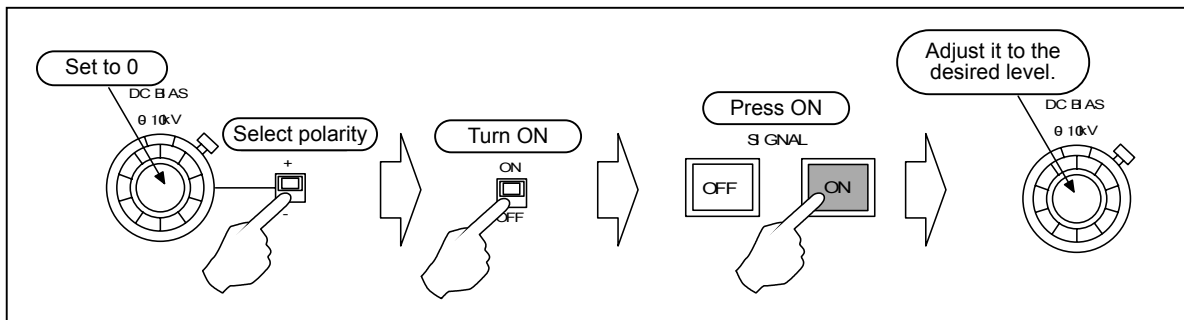

Figure4-31. Using internal DC bias signal

b) Using external oscillator

Connect the external oscillator to OSC INPUT and make sure that the oscillator output level is 0V. Set the GAIN knob to TOP. Turn ON the external oscillator ON/OFF switch and press ON of the SIGNAL switch. While reading the value on the voltmeter or oscilloscope connected to the voltage monitor, increase the output level of the oscillator gradually.

If fine adjustment of the output level is required, adjust it at the oscillator or adjust it with GAIN of the unit. Turn GAIN to the left, the gain is decreased. Turn GAIN to the right, the gain is increased. The gain can be adjusted in the range of approximately $\pm 3\%$.

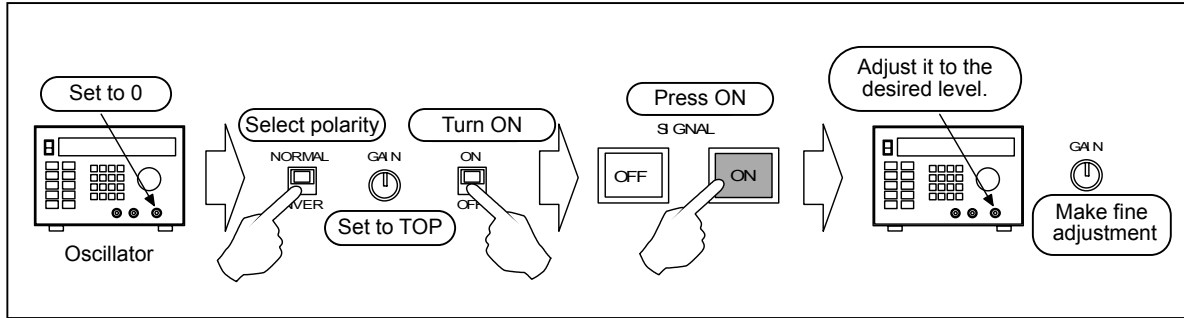

Figure4-32. Using external oscillator

c) Using external DC bias signal source

Connect the DC standard power supply to EXT DC BIAS INPUT and make sure that the output of the standard power supply is 0V. Turn ON the external DC bias ON/OFF switch and press ON of the SIGNAL switch.

While reading the value on the voltmeter or oscilloscope connected to the voltage monitor, increase the output level of the DC standard power supply gradually and set the desired voltage.

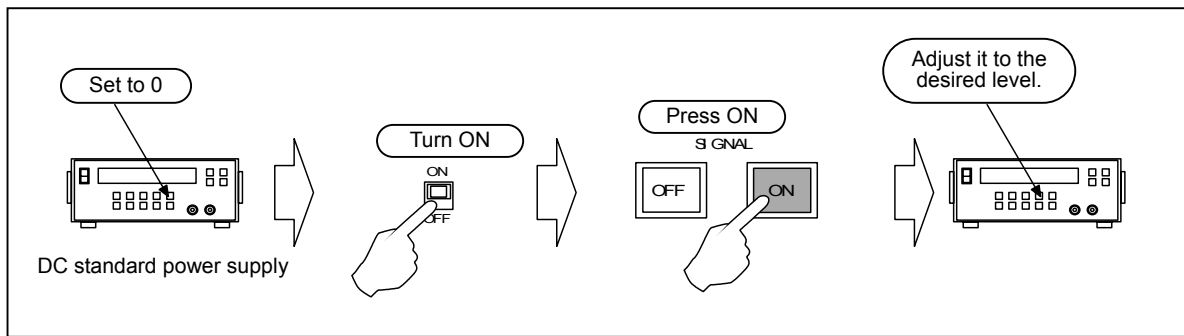

Figure4-33. Using external DC bias signal

■ High voltage display

When the output voltage exceeds $\pm 130\text{V}$ to $\pm 150\text{V}$, the high voltage output LED lights and starts rotation slowly. The higher the output voltage is, the faster the rotation is.

When the voltage exceeds $\pm 4.9\text{ kV}$, the color changes from orange to red.

■ Gain adjustment with RESPONSE

The gain of 200 kHz band or more may vary depending on the RESPONSE knob position. Refer to "5.3 Characteristics in constant voltage mode, Chapter 5".

When the frequency is used at 200 Hz or more, measure the output voltage of the voltage monitor and adjust RESPONSE so that the desired amplitude may be obtained.

4.2 Operation example in constant current mode (total)

WARNING

It is very dangerous during output of high voltage. Never touch the output cable or the high voltage area. If you find a dangerous status due to a unit error or load error, turn OFF the POWER switch immediately.

4.2.5 Signal OFF

a) Input signal OFF

To set the output signal to 0V temporarily, press OFF of the SIGNAL switch.

WARNING

When SIGNAL is OFF, the output voltage is 0V, but the internal high voltage DC power supply is ON. It continuously gives high voltage output.

In this status, never touch the output cable or the high voltage area for safety.

b) Internal high voltage DC power supply OFF

When the HIGH VOLTAGE POWER SUPPLY switch is turned OFF, the output of the internal high voltage DC power supply is 0V and the amplifier cannot give high voltage output.

4.3 Operation example in constant current mode (load)

This section describes operation example of this unit in load mode of constant current mode.

In constant current mode, the output current varies according to the input signal.

In load mode, load current is correctly controlled ignoring effect due to leak current with cable capacity.

Effect of stray capacitance of the cable is found only for AC signal output. Effect of stray signal is not found for DC signal. Therefore, use the unit in total mode for DC signal.

In load mode, leak current with stray capacitance and load current are detected from different routes. Therefore, load mode cannot be used for load which is grounded.

WARNING

When the internal high voltage DC power supply is ON and SIGNAL is ON with the output open, maximum ± 12 kV output is given to the OUTPUT Hi terminal. It is very dangerous. Do not turn ON SIGNAL when the output is open.

In constant current mode, be sure to connect load or short-circuit the output.

When the internal high voltage DC power supply is ON and SIGNAL is OFF with the output open, ± 100 V voltage output may be given to the OUTPUT Hi terminal depending on the voltage limiter settings.

WARNING

In constant current mode, DC cannot be run for capacity load. At this time, the output for DC signal is the same as that in open status. When SIGNAL is ON, maximum ± 12 kV output is given to the OUTPUT Hi terminal.

Never apply DC to capacity load in constant current mode.

4.3 Operation example in constant current mode (load)

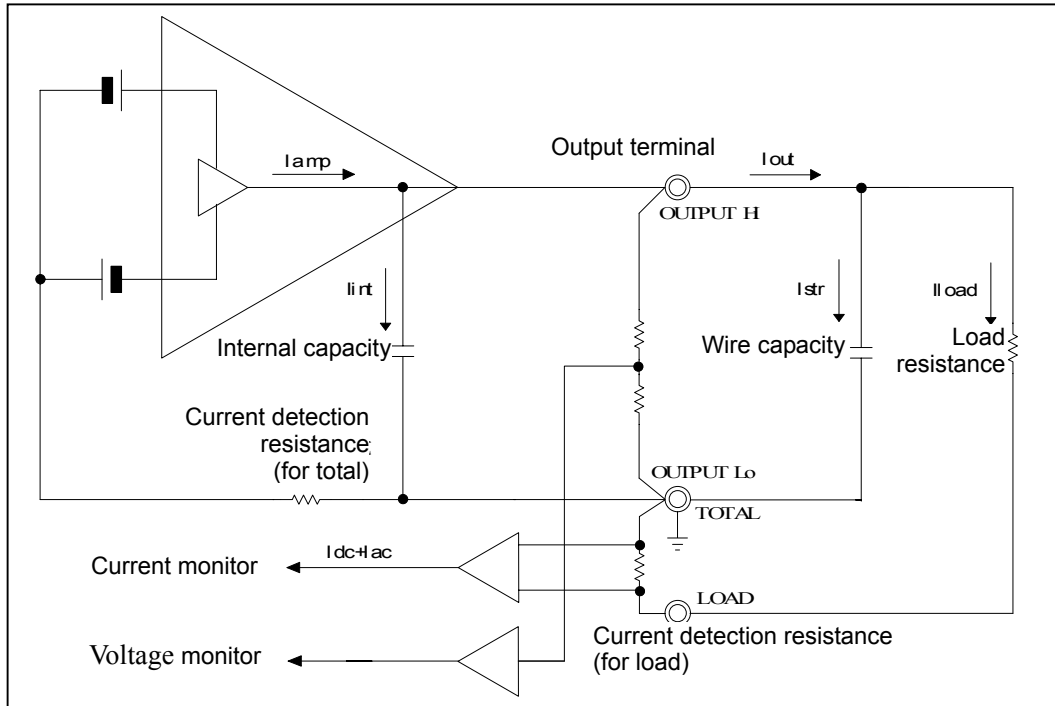

Figure4-34. Load mode

- I_{amp} : Output current of amplifier
- I_{int} : Leak current with internal capacity
- I_{out} : Output current
- I_{str} : Leak current with wire capacity
- I_{load} : Load current
- I_{dc}, I_{ac} : DC and AC of detected current

Not all current I_{out} from the output terminal is supplied to load. There is leak of I_{str} with wire capacity. Actual current to load is $I_{load} = I_{out} - I_{str}$.

In load mode, I_{load} and I_{str} are returned through different routes and only I_{load} is detected to control output current.

Therefore, Set current = I_{load}

$$I_{out} = I_{load} + I_{str}$$

CAUTION

Current I_{out} from the output terminal cannot exceed the maximum current of this unit.

In load mode, load current is directly detected. Only load current can be monitored with the current monitor.

4.3.1 Panel setting

a) Internal high voltage DC power supply OFF

When HIGH VOLTAGE POWER SUPPLY is not OFF, press the button until a "click" sound is heard. When a click sound is heard, the switch is locked in OFF status. The internal high voltage DC power supply is always OFF.

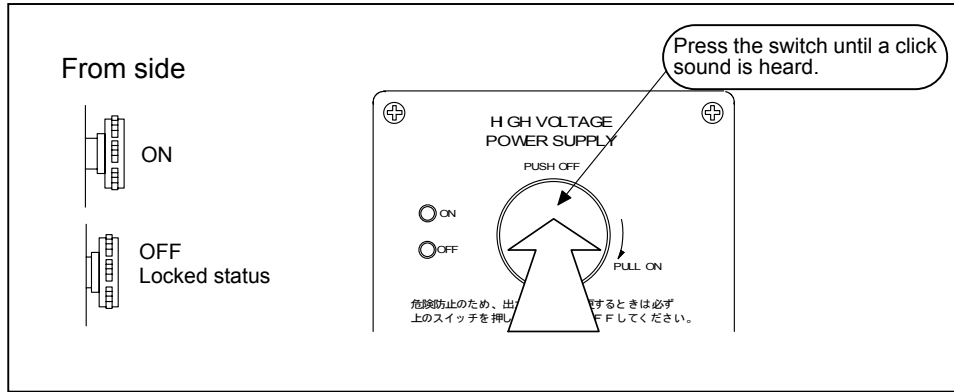

Figure4-35. Internal high voltage DC power OFF

b) Signal system OFF

Turn the internal DC bias knob to the leftmost position to minimize the value. Turn OFF the switches of DC BIAS, OSC INPUT and EXT DC BIAS INPUT.

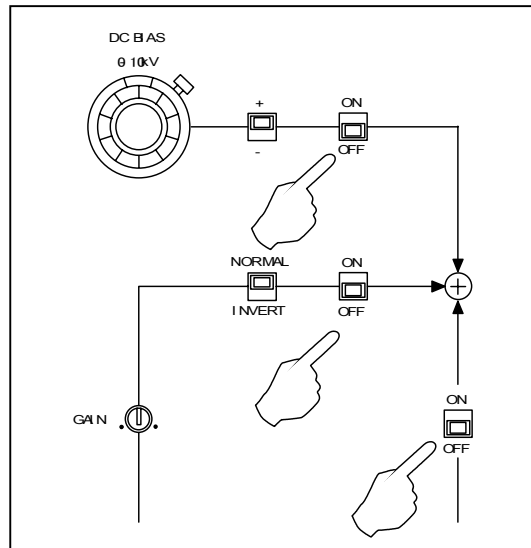

Figure4-36. Switch settings

4.3 Operation example in constant current mode (load)

c) Output mode settings

Set the output mode switch to CC. Set the DC BIAS to CC.

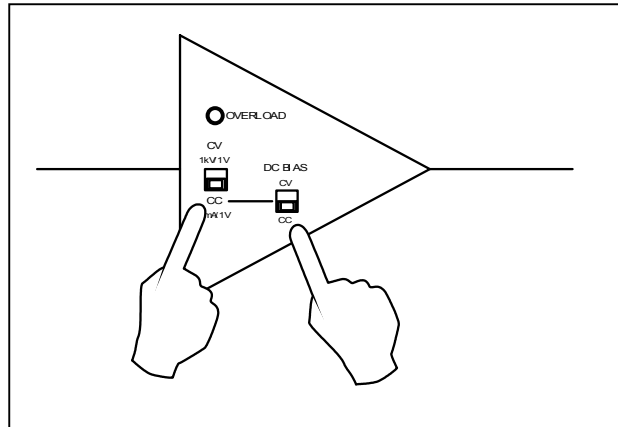

Figure4-37. Output mode settings

d) Remote/local settings

To operate this unit from the panel, set the ON/OFF CONTROL switch to LOCAL.

Refer to "4.6 Remote control operation" for remote control operation.

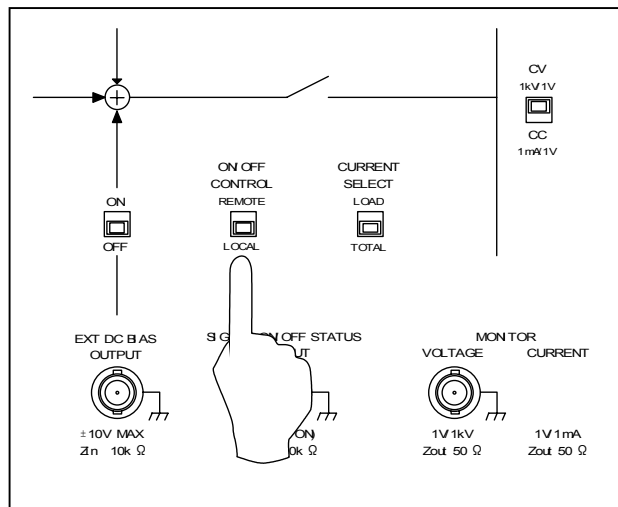

Figure4-38. Local settings

e) Output limiter settings

To limit the output voltage and output current, set the limiter level as required.

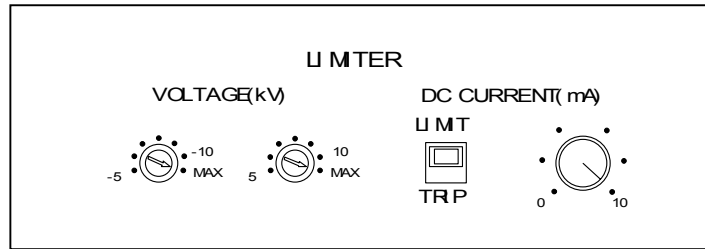

Figure4-39. Limiter settings

■ Voltage limiter

The voltage limiter function can limit the maximum value of the output voltage independently for positive and negative values in the range from ± 5 kV to ± 10 kV. For example, the output is sufficient up to ± 8 kV, set the VOLTAGE LIMITER to 8 kV and -8 kV.

When voltage limitation is not required, set it to MAX.

■ Current limiter

The current limiter function can limit the average value of the output current in the range from 0 mA to ± 10 mA. For example, to limit the output current up to 5 mA, set it to 5 mA.

When current limitation is not required, set it to 10 mA which is turned to the rightmost position.

■ LIMIT/TRIP

Set the protection mode for activation of the current limiter. When LIMIT is selected, current is limited to the set current. When TRIP is selected, the input signal is immediately OFF for activation of the current limiter circuit and the output is 0V.

Select either one as required.

f) Current monitor mode settings

In load mode of constant current mode, set it to LOAD CURRENT.

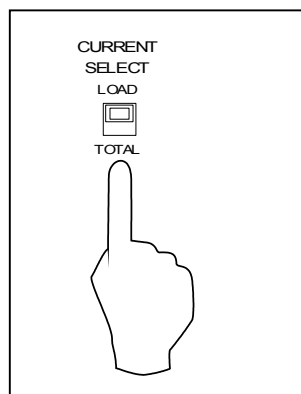

Figure4-40. Current monitor mode settings

4.3 Operation example in constant current mode (load)

g) RESPONSE knob settings

Set the CC RESPONSE knob to the rightmost position.

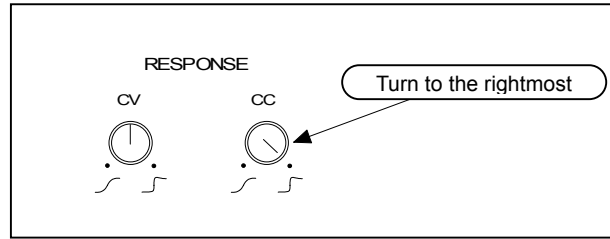

Figure4-41. Response settings

4.3.2 Connection of signal source and connection of load

a) Connection of input signal source

Give the signal generator (e.g. oscillator) output to OSC INPUT. When applying the external DC bias, give the DC signal source output to EXT DC BIAS INPUT.

The input voltage of the OSC INPUT terminal and the EXT DC BIAS INPUT terminal is maximum $\pm 10V$.

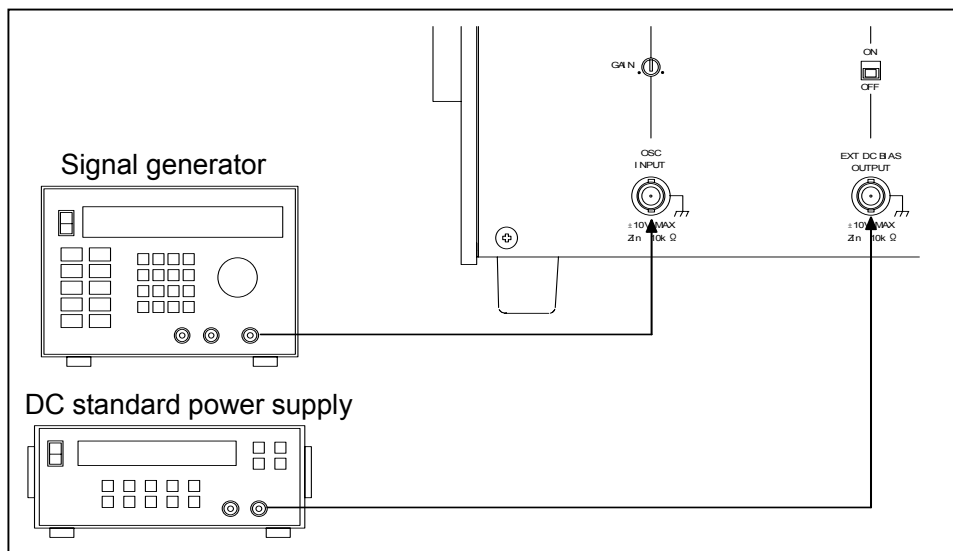

Figure4-42. Connection of external signal source signal

4.3 Operation example in constant current mode (load)

b) Monitor signal output

Connect a measuring instrument such as oscilloscope or voltmeter to VOLTAGE MONITOR or CURRENT MONITOR as required.

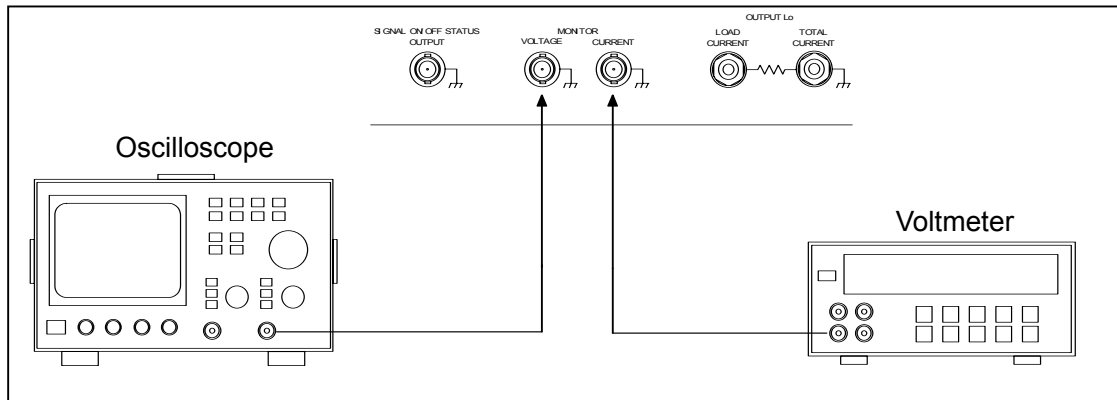

Figure4-43. Connection of monitor

c) Connection of load

Be sure to use the accompanying cable for the cable connected to Hi.

To minimize effect from stray capacitance, shorten the cable length as much as possible and keep it away from the floor or other devices.

Connect the return wire from load to the LOAD CURRENT terminal. Connect the ground line where leak current runs with stray capacitance to the TOTAL CURRENT terminal.

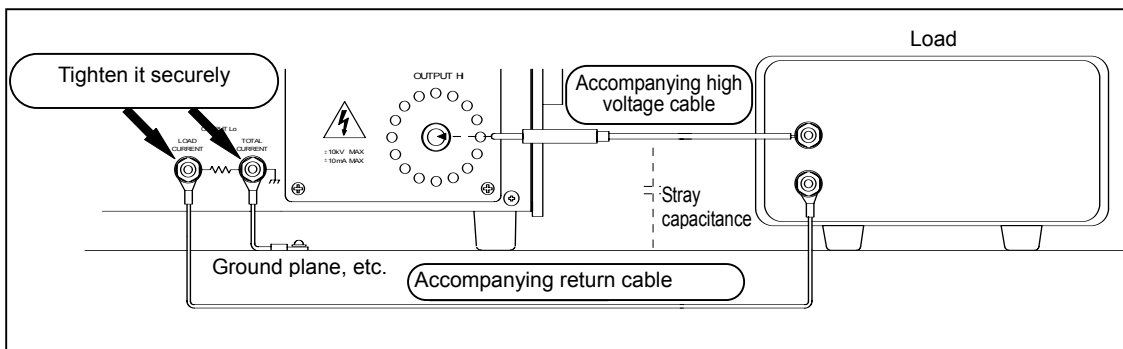

Figure4-44. Connection of output cable

4.3 Operation example in constant current mode (load)

 **CAUTION**

In load mode, be sure to use the LOAD CURRENT terminal for the return terminal of load current.
Use the TOTAL CURRENT terminal for the return terminal of leak current.

 **WARNING**

Tighten the binding post terminal of OUTPUT Lo securely. If it is loose, electric shock may occur when touching the load grounding or the return cable.

Check sometimes if it is not loose when it is safe with the power OFF.

4.3.3 Power supply and internal high voltage DC power supply

a) Power supply

Before supply of power, check again if the HIGH VOLTAGE POWER SUPPLY switch is OFF (button is pressed). After checking connection to load, connection to the signal source and if the panel settings are correct, turn ON the POWER switch of the unit.

When the power is ON, the fan at the back starts operation.

On the panel surface:

- The OFF lamp of the signal switch blinks.
- The OFF LED of the internal high voltage DC power supply lights.

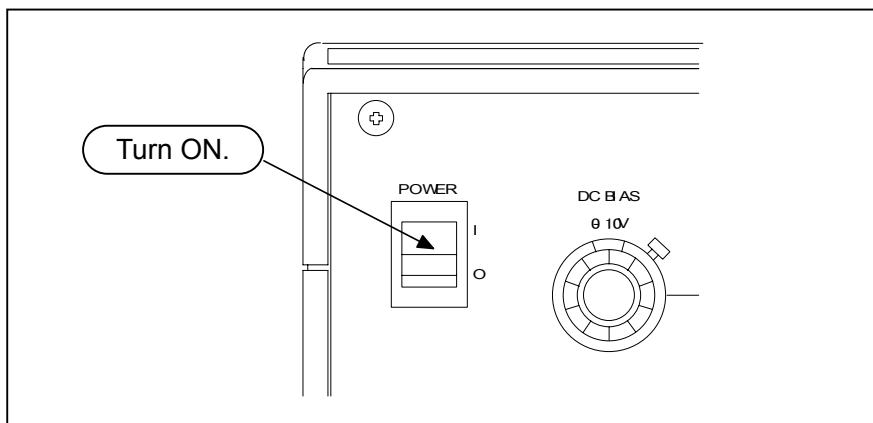

Figure4-45. Power supply

b) Supply of high voltage DC power

Turn the HIGH VOLTAGE POWER SUPPLY switch to the right and unlock it. Turn ON the internal high voltage power supply. The ON LED of the internal high voltage power supply lights. In several seconds, the SIGNAL switch OFF lamp changes from blinking to lighting.

When the power is supplied, the internal high voltage DC power supply is always OFF regardless of ON/OFF status of the HIGH VOLTAGE POWER SUPPLY switch. If this switch is ON, turn OFF once and turn it ON again.

4.3 Operation example in constant current mode (load)

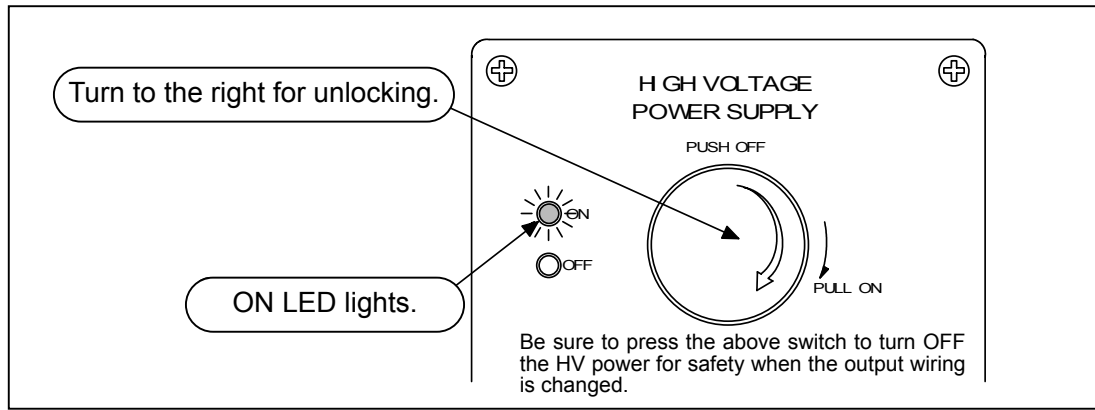

Figure4-46. Internal high voltage DC power ON

⚠ WARNING

After this operation, the internal high voltage DC power supply is ON. High voltage is generated inside the unit.

Be careful not to touch the area like an output terminal to which high voltage is applied.

- When the SIGNAL OFF switch remains blinking.

When the SIGNAL OFF switch remains blinking after unlocking the HIGH VOLTAGE POWER SUPPLY switch, check the following:

- 1) Is the shorting plug inserted into the HIGH VOLTAGE POWER SUPPLY ON/OFF terminal at the back?

Action

Insert the shorting plug for operation in LOCAL mode.

- 2) Is the DC CURRENT value the minimum and is TRIP selected?

Action

Increase the current limit or select LIMIT.

- 3) Is temperature of exhaust air extremely high?

Action

Temperature in the casing may be too high. Leave the unit at a cool environment for dozens of minutes. Then, turn ON the HIGH VOLTAGE POWER SUPPLY switch again.

- 4) Are all fans at the back operating?

Action

Check if there is any object that blocks rotation of a fan. If a fan does not rotate without any blocking, the fan may be faulty. It must be repaired.

When either of the above is not applicable, the internal high voltage DC power supply may be faulty. In this case, it must be repaired.

4.3.4 Signal output and adjustment

a) Using internal DC bias signal source

Make sure that the internal DC signal source dial is 0. Set the polarity switch to the desired polarity. Turn ON the internal DC bias signal source ON/OFF switch and press ON of the SIGNAL switch. While reading the value on the voltmeter or oscilloscope connected to the voltage monitor, turn the dial gradually to the right. Set it to the desired voltage.

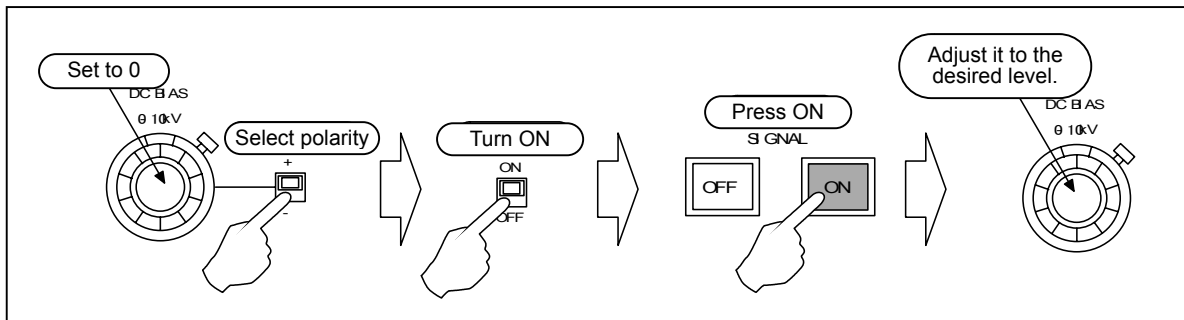

Figure4-47. Using internal DC bias signal

b) Using external oscillator

Connect the external oscillator to OSC INPUT and make sure that the oscillator output level is 0V. Set the GAIN knob to UP. Turn ON the external oscillator ON/OFF switch and press ON of the SIGNAL switch. While reading the value on the voltmeter or oscilloscope connected to the voltage monitor, increase the output level of the oscillator gradually.

If fine adjustment of the output level is required, adjust it at the oscillator or adjust it with GAIN of the unit. Turn GAIN to the left, the gain is decreased. Turn GAIN to the right, the gain is increased. The gain can be adjusted in the range of approximately $\pm 3\%$.

4.3 Operation example in constant current mode (load)

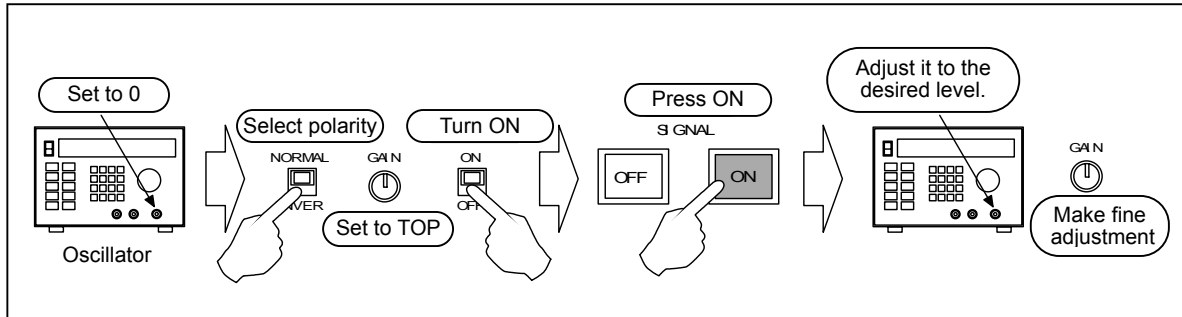

Figure4-48. Using external oscillator

c) Using external DC bias signal source

Connect the DC standard power supply to EXT DC BIAS INPUT and make sure that the output of the standard power supply is 0V. Turn ON the external DC bias ON/OFF switch and press ON of the SIGNAL switch.

While reading the value on the voltmeter or oscilloscope connected to the voltage monitor, increase the output level of the DC standard power supply gradually and set the desired voltage.

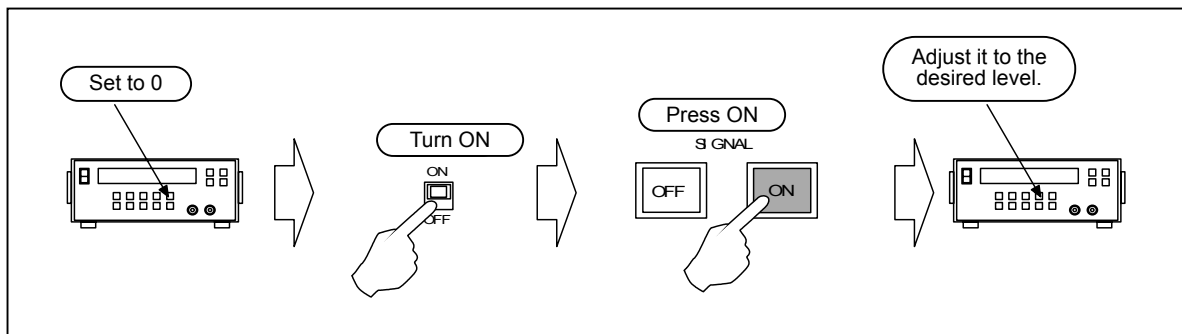

Figure4-49. Using external DC bias signal

■ High voltage display

When the output voltage exceeds $\pm 130\text{V}$ to $\pm 150\text{V}$, the high voltage output LED lights and starts rotation slowly. The higher the output voltage is, the faster the rotation is.

When the voltage exceeds $\pm 4.9\text{ kV}$, the color changes from orange to red.

■ Gain adjustment with RESPONSE

The gain of the 200 Hz band or more may vary depending on the RESPONSE knob position. Refer to "5.3 Characteristics in constant voltage mode, Chapter 5".

When the frequency is used at 200 Hz or more, measure the output voltage of the voltage monitor and adjust RESPONSE so that the desired amplitude may be obtained.

 **WARNING**

It is very dangerous during output of high voltage. Never touch the output cable or the high voltage area. If you find a dangerous status due to a unit error or load error, turn OFF the power switch immediately.

4.3.5 Signal OFF

a) Input signal OFF

To set the output signal to 0V temporarily, press OFF of the SIGNAL switch.

 **WARNING**

When SIGNAL is OFF, the output voltage is 0V, but the internal high voltage DC power supply is ON. It continuously gives high voltage output.

In this status, never touch the output cable or the high voltage area for safety.

b) Internal high voltage DC power supply OFF

When the HIGH VOLTAGE POWER SUPPLY switch is turned OFF, the output of the internal high voltage DC power supply is 0V and the amplifier cannot give high voltage output.

4.4 Operation example in constant current + constant voltage mode

This section describes operation example of this unit in constant current + constant voltage mode.

In this mode, AC signal is constant current and DC signal is constant voltage. This mode is used to run AC by applying DC bias to capacity load.

In constant current mode, total mode and load mode previously described can be selected.

The frequency at the boundary of the constant voltage operation and the constant current operation varies depending on the load capacity.

Refer to "3.2.1 Amplifier operation mode, Chapter 3" and "Figure5.4 and Figure5-12, 5.4, Chapter 5".

The TOTAL terminal of OUTPUT Lo is connected to the casing. Therefore, the total mode can be used for grounded load or load that can be grounded.

⚠ CAUTION

In load mode, leak current with stray capacitance and load current are detected from different routes. Therefore, load mode cannot be used for load which is grounded.

⚠ CAUTION

Constant current operation is available for AC signal and constant voltage operation is available for DC signal. When the signal is ON, unusual voltage output is not given with the output open. When the output is short-circuited, be careful for DC short-circuit current.

4.4 Operation example in constant current + constant voltage mode

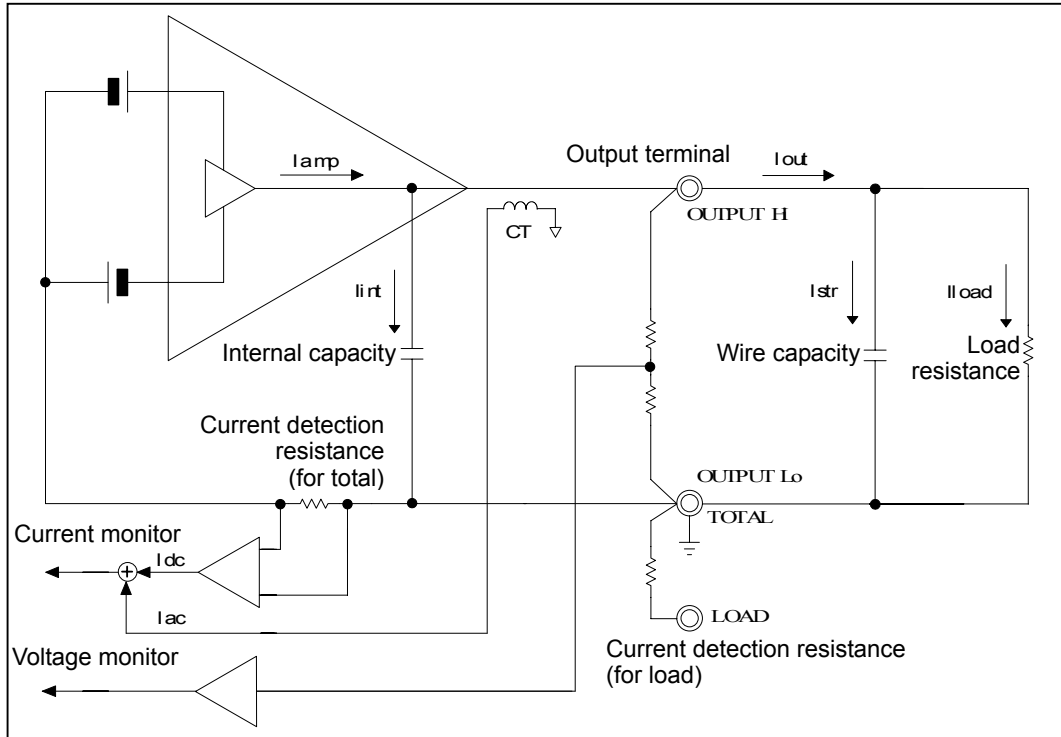

Figure4-50. Constant current constant voltage mode (total mode)

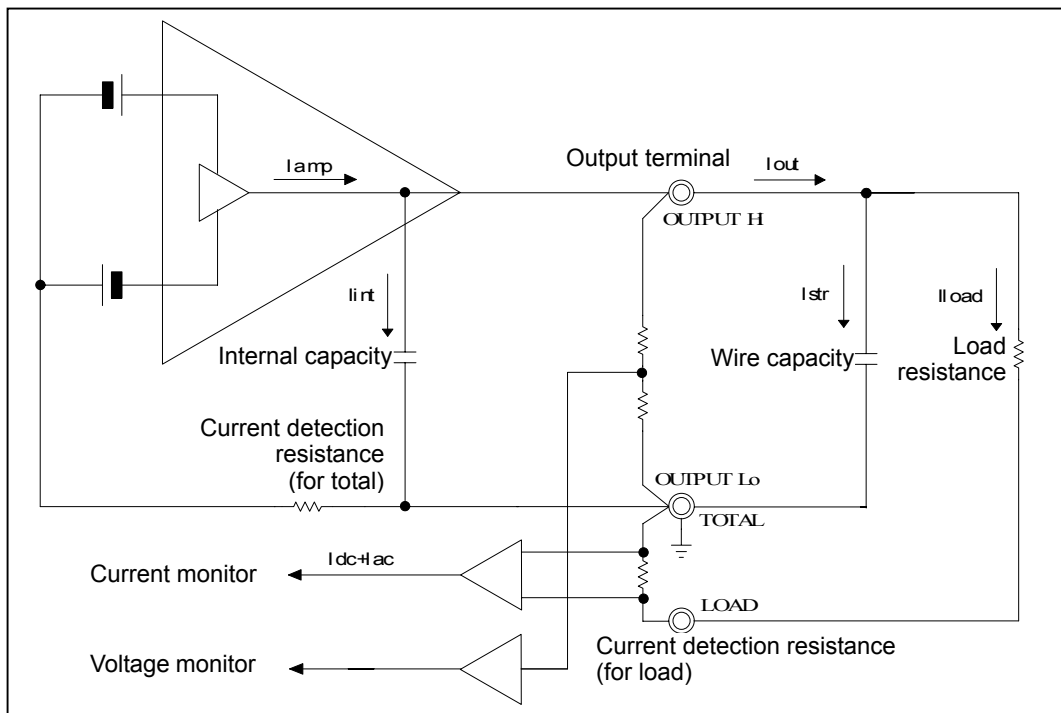

Figure4-51. Constant current constant voltage mode (load mode)

In constant current + constant voltage mode, the current detection circuit detects AC components and the voltage detection circuit detects DC components for independent control.

Total mode and load mode can be used same as normal constant current mode.

4.4.1 Panel setting

a) Internal high voltage DC power supply OFF

When HIGH VOLTAGE POWER SUPPLY switch is not OFF, press the button until a "click" sound is heard. When a click sound is heard, the switch is locked in OFF status. The internal high voltage DC power supply is always OFF.

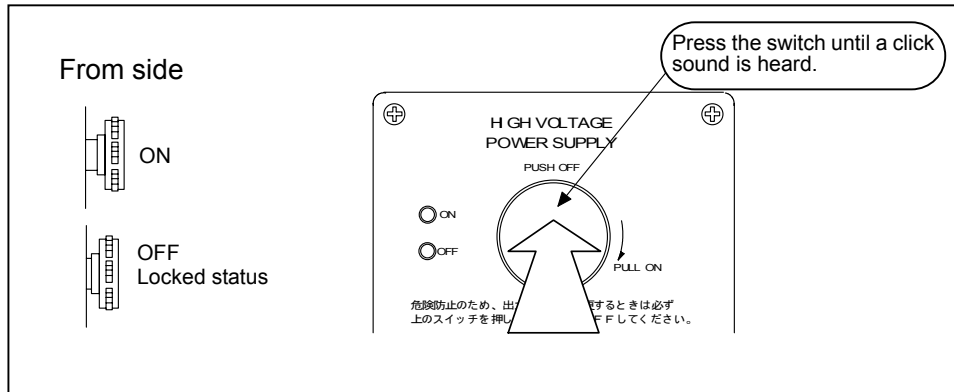

Figure4-52. Internal high voltage DC power OFF

b) Signal system OFF

Turn the internal DC bias knob to the leftmost position to minimize the value. Turn OFF the switches of DC BIAS, OSC INPUT and EXT DC BIAS INPUT.

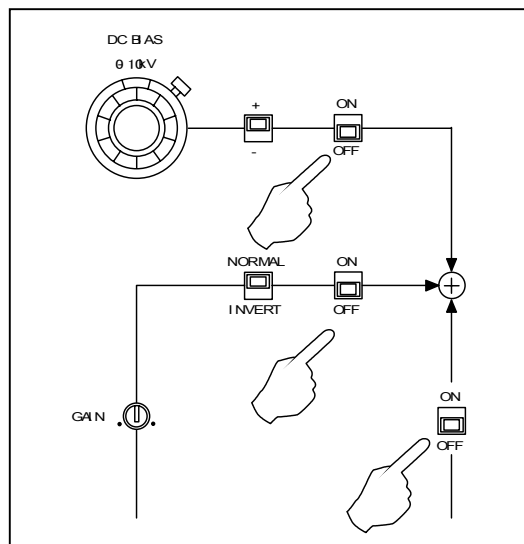

Figure4-53. Switch settings

4.4 Operation example in constant current + constant voltage mode

c) Output mode settings

Set the output mode switch to CC. Set the DC BIAS to CV.

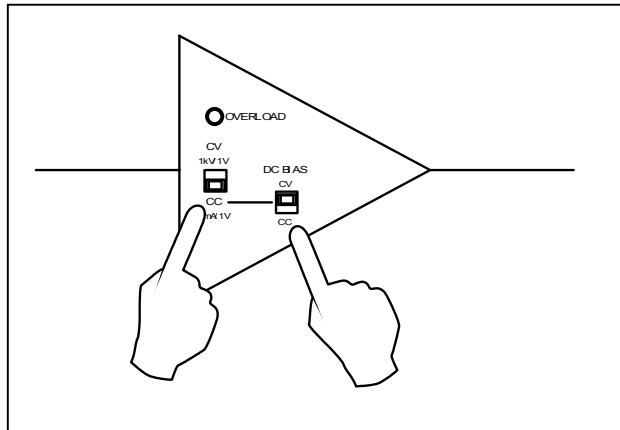

Figure4-54. Output mode settings

d) Remote/local settings

To operate this unit from the panel, set the ON/OFF CONTROL switch to LOCAL. Refer to "4.6 Remote control operation" for remote control operation.

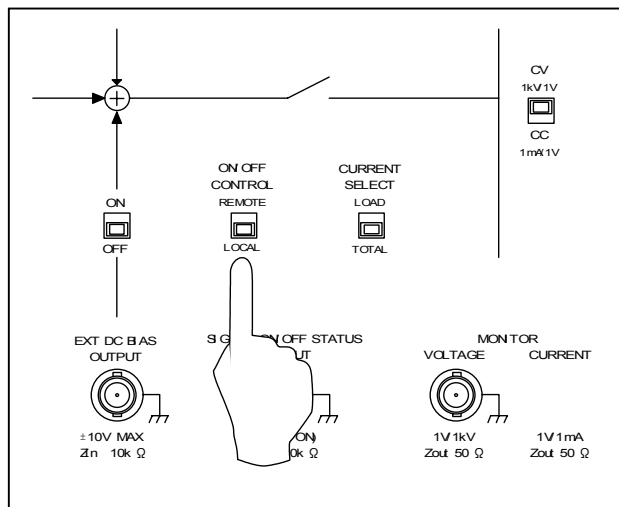

Figure4-55. Local settings

4.4 Operation example in constant current + constant voltage mode

e) Output limiter settings

To limit the output voltage and output current, set the limiter level as required.

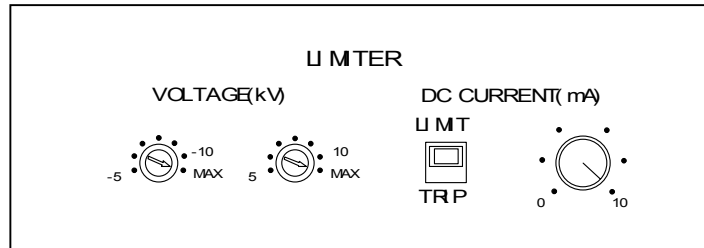

Figure4-56. Limiter settings

■ Voltage limiter

The voltage limiter function can limit the maximum value of the output voltage independently for positive and negative values in the range from ± 5 kV to ± 10 kV.

For example, the output is sufficient up to ± 8 kV, set the VOLTAGE LIMITER to 8 kV and -8 kV.

When voltage limitation is not required, set it to MAX.

■ Current limiter

The current limiter function can limit the average value of the output current in the range from 0 mA to ± 10 mA.

For example, to limit the output current up to 5 mA, set it to 5 mA.

When current limitation is not required, set it to 10 mA which is turned to the rightmost position.

■ LIMIT/TRIP

Set the protection mode for activation of the current limiter. When LIMIT is selected, current is limited to the set current. When TRIP is selected, the input signal is immediately OFF for activation of the current limiter circuit and the output is 0V.

Select either one as required.

f) Current monitor mode settings

In total mode, set it to TOTAL CURRENT. In load mode, set it to LOAD CURRENT.

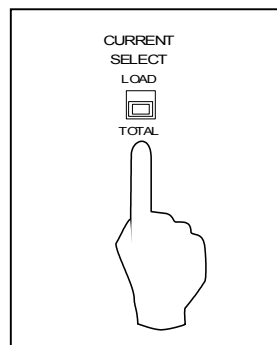

Figure4-57. Current monitor mode settings

4.4 Operation example in constant current + constant voltage mode

g) RESPONSE knob settings

Set the CC RESPONSE knob to the rightmost position. (CV is invalid.)

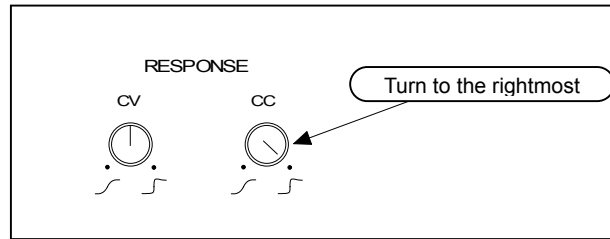

Figure4-58. Response settings

4.4.2 Connection of signal source and connection of load

a) Connection of input signal source

Give the signal generator (e.g. oscillator) output, which is the signal source of constant current, to OSC INPUT. When applying the external constant voltage signal source, give it to EXT DC BIAS INPUT.

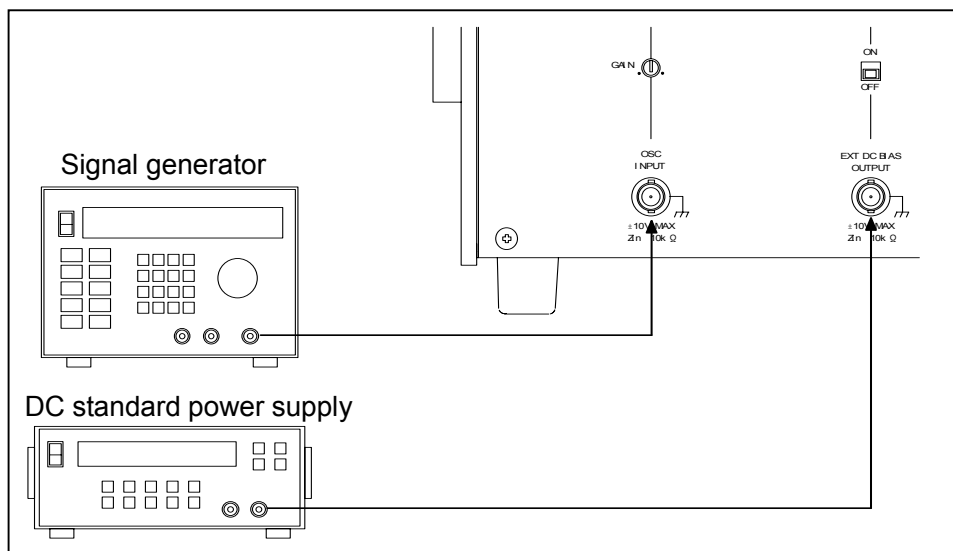

Figure4-59. Connection of external signal source signal

4.4 Operation example in constant current + constant voltage mode

CAUTION

The DC signal in the internal bias signal source or EXT DC BIAS INPUT can be used as the constant voltage signal source.

If a DC input is given into OSC INPUT, the DC component is cancelled in this unit and the output is not given.

CAUTION

The DC signal in the internal bias signal source or EXT DC BIAS INPUT can be used as the constant voltage signal source.

If a DC input is given into OSC INPUT, the DC component is cancelled in this unit and the output is not given.

b) Monitor signal output

Connect a measuring instrument such as oscilloscope or voltmeter to VOLTAGE MONITOR or CURRENT MONITOR as required.

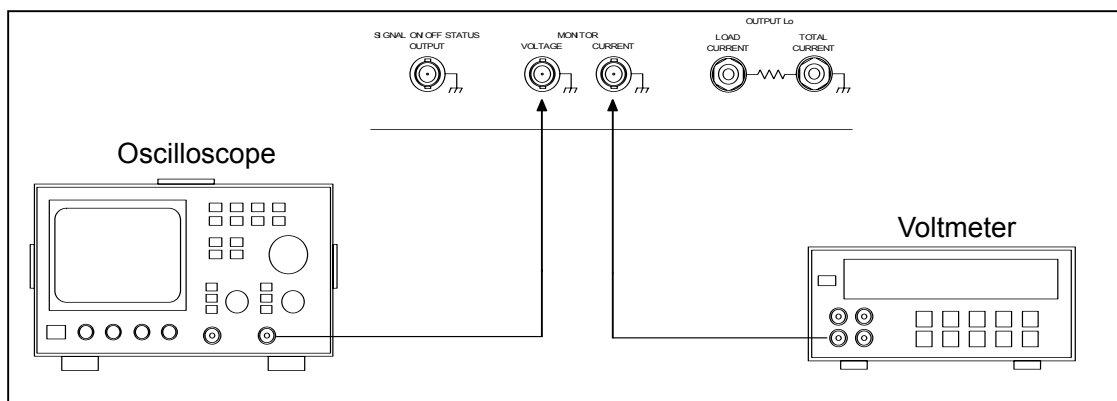

Figure4-60. Connection of monitor

4.4 Operation example in constant current + constant voltage mode

c) Connection of load

Be sure to use the accompanying cable for the cable connected to Hi. To minimize effect from stray capacitance, shorten the cable length as much as possible and keep it away from the floor or other devices.

Connect the return wire to TOTAL CURRENT terminal and LOAD CURRENT terminal according to the total/load mode settings.

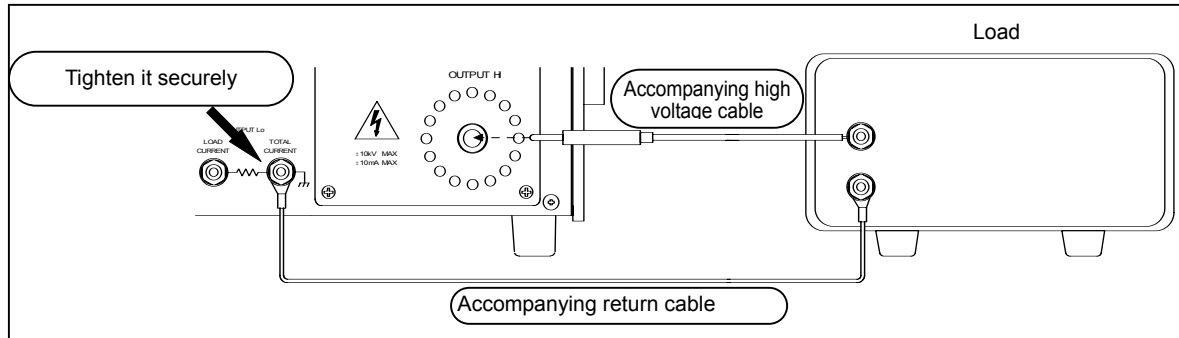

Figure4-61. Connection of output cable

⚠ WARNING

Tighten the binding post terminal of OUTPUT Lo securely. If it is loose, electric shock may occur when touching the load grounding or the return cable.

Check sometimes if it is not loose when it is safe with the power OFF.

4.4.3 Power supply and internal high voltage DC power supply

a) Power supply

Before supply of power, check again if the HIGH VOLTAGE POWER SUPPLY switch is OFF (button is pressed). After checking connection to load, connection to the signal source and if the panel settings are correct, turn ON the POWER switch of the unit.

When the power is ON, the fan at the back starts operation.

On the panel surface:

- The OFF lamp of the signal switch blinks.
- The OFF LED of the internal high voltage DC power supply lights.

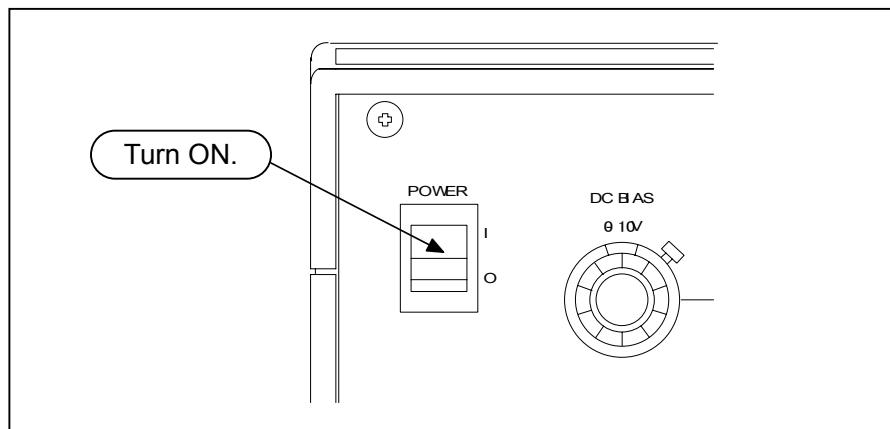

Figure4-62. Power supply

b) Supply of high voltage DC power

Turn the HIGH VOLTAGE POWER SUPPLY switch to the right and unlock it. Turn ON the internal high voltage power supply. The ON LED of the internal high voltage power supply lights. In several seconds, the SIGNAL switch OFF lamp changes from blinking to lighting.

When the power is supplied, the internal high voltage DC power supply is always OFF regardless of ON/OFF status of the HIGH VOLTAGE POWER SUPPLY switch. If this switch is ON, turn OFF once and turn it ON again.

4.4 Operation example in constant current + constant voltage mode

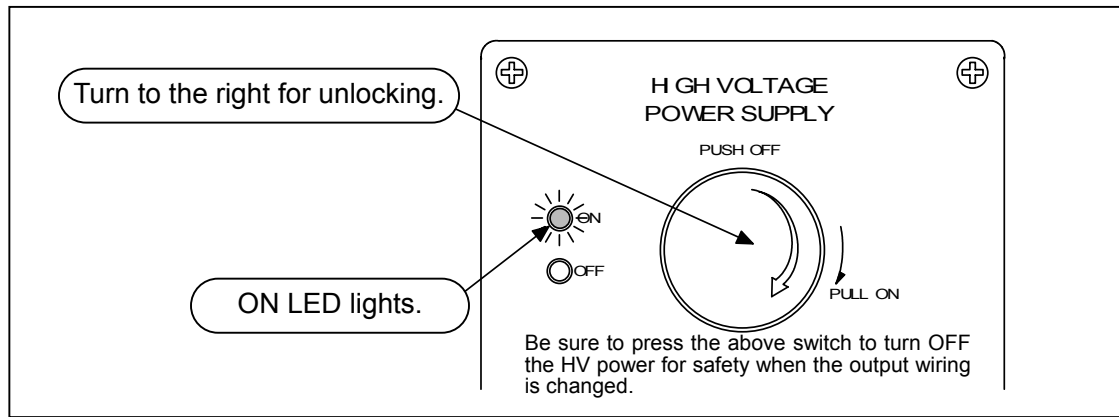

Figure4-63. Internal high voltage DC power ON

⚠ WARNING

After this operation, the internal high voltage DC power supply is ON. High voltage is generated inside the unit.

Be careful not to touch the area like an output terminal to which high voltage is applied.

- When the SIGNAL OFF switch remains blinking.

When the SIGNAL OFF switch remains blinking after unlocking the HIGH VOLTAGE POWER SUPPLY switch, check the following:

- 1) Is the shorting plug inserted into the HIGH VOLTAGE POWER SUPPLY ON/OFF terminal at the back?

Action

Insert the shorting plug for operation in LOCAL mode.

- 2) Is the DC CURRENT value the minimum and is TRIP selected?

Action

Increase the current limit or select LIMIT.

- 3) Is temperature of exhaust air extremely high?

Action

Temperature in the casing may be too high. Leave the unit at a cool environment for dozens of minutes. Then, turn ON the HIGH VOLTAGE POWER SUPPLY switch again.

- 4) Are all fans at the back operating?

Action

Check if there is any object that blocks rotation of a fan. If a fan does not rotate without any blocking, the fan may be faulty. It must be repaired.

4.4 Operation example in constant current + constant voltage mode

When either of the above is not applicable, the internal high voltage DC power supply may be faulty. In this case, it must be repaired.

4.4.4 Signal output and adjustment

a) Using internal DC bias signal source

Make sure that the internal DC signal source dial is 0. Set the polarity switch to the desired polarity. Turn ON the internal DC bias signal source ON/OFF switch and press ON of the SIGNAL switch. While reading the value on the voltmeter or oscilloscope connected to the voltage monitor, turn the dial gradually to the right. Set it to the desired voltage.

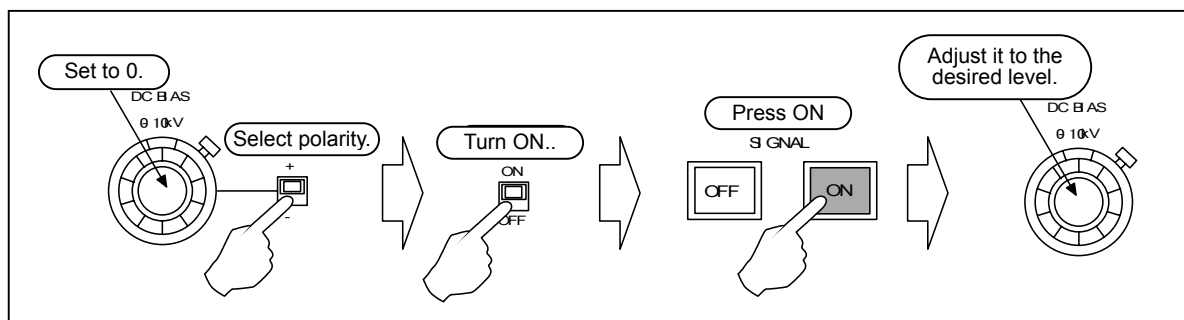

Figure4-64. Using internal DC bias signal

b) Using external oscillator

Connect the external oscillator to OSC INPUT and make sure that the oscillator output level is 0V. Set the GAIN knob to UP. Turn ON the external oscillator ON/OFF switch and press ON of the SIGNAL switch. While reading the value on the voltmeter or oscilloscope connected to the voltage monitor, increase the output level of the oscillator gradually.

If fine adjustment of the output level is required, adjust it at the oscillator or adjust it with GAIN of the unit. Turn GAIN to the left, the gain is decreased. Turn GAIN to the right, the gain is increased. The gain can be adjusted in the range of approximately $\pm 3\%$.

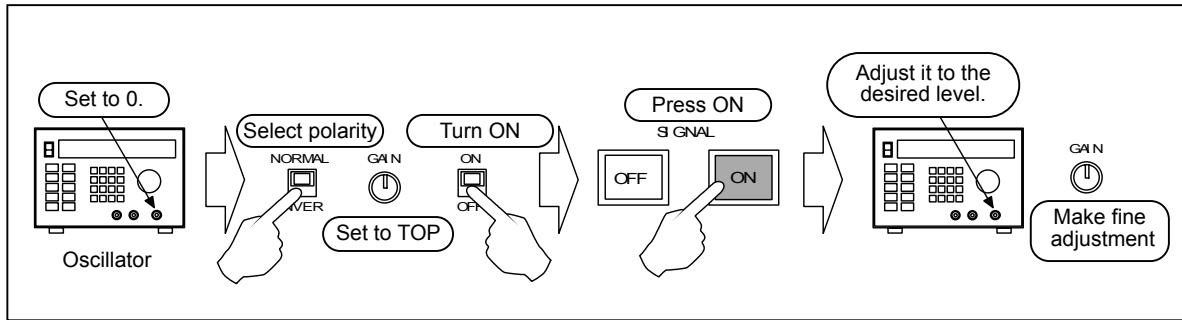

Figure4-65. Using external oscillator

c) Using external DC bias signal source

Connect the DC standard power supply to EXT DC BIAS INPUT and make sure that the output of the standard power supply is 0V. Turn ON the external DC bias ON/OFF switch and press ON of the SIGNAL switch.

While reading the value on the voltmeter or oscilloscope connected to the voltage monitor, increase the output level of the DC standard power supply gradually and set the desired voltage.

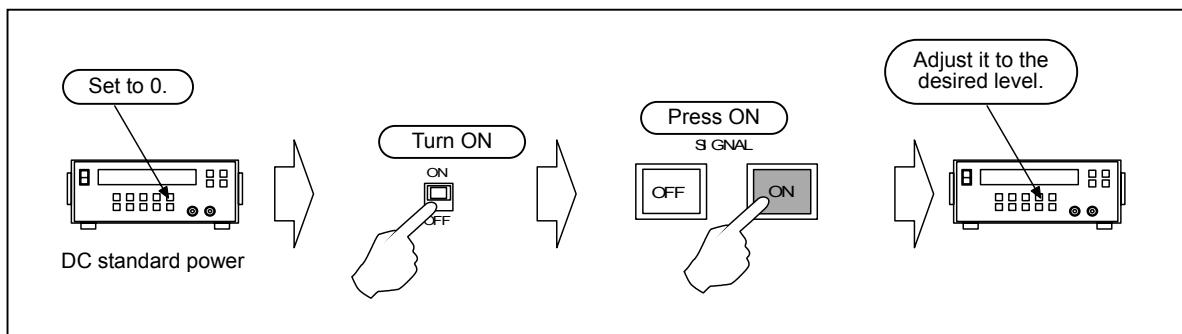

Figure4-66. Using external DC bias signal

■ High voltage display

When the output voltage exceeds $\pm 130\text{V}$ to $\pm 150\text{V}$, the high voltage output LED lights and starts rotation slowly. The higher the output voltage is, the faster the rotation is.

When the voltage exceeds $\pm 4.9\text{ kV}$, the color changes from orange to red.

■ Gain adjustment with RESPONSE

The gain in the AC range may vary depending on the RESPONSE knob position. Refer to "5.4 Characteristics of constant current + constant voltage mode, Chapter 5".

When the frequency is used at specific frequency, measure the output voltage of the voltage monitor and adjust RESPONSE so that the desired amplitude may be obtained.

4.4 Operation example in constant current + constant voltage mode

WARNING

It is very dangerous during output of high voltage. Never touch the output cable or the high voltage area. If you find a dangerous status due to a unit error or load error, turn OFF the power switch immediately.

4.4.5 Signal OFF

a) Input signal OFF

To set the output signal to 0V temporarily, press OFF of the SIGNAL switch.

WARNING

When SIGNAL is OFF, the output voltage is 0V, but the internal high voltage DC power supply is ON. It continuously gives high voltage output.

In this status, never touch the output cable or the high voltage area for safety.

b) Internal high voltage DC power supply OFF

When the HIGH VOLTAGE POWER SUPPLY switch is turned OFF, the output of the internal high voltage DC power supply is 0V and the amplifier cannot give high voltage output.

4.5 Change of load and power OFF

4.5.1 Change of load

a) Input signal OFF

To set the output signal to 0V temporarily, press OFF of the SIGNAL switch.

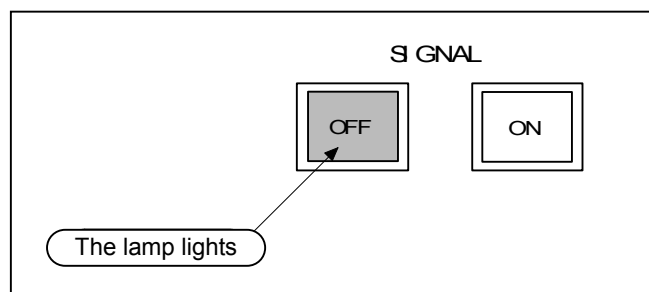

Figure4-67. Input signal OFF

⚠ WARNING

When this SIGNAL is OFF, the internal high voltage DC power supply continuously gives high voltage output.

In this status, never touch the output cable or the high voltage area for safety to change load.

b) Internal high voltage DC power supply OFF

Press the HIGH VOLTAGE POWER SUPPLY switch to turn it OFF. When this switch is OFF, the internal high voltage DC power supply is OFF.

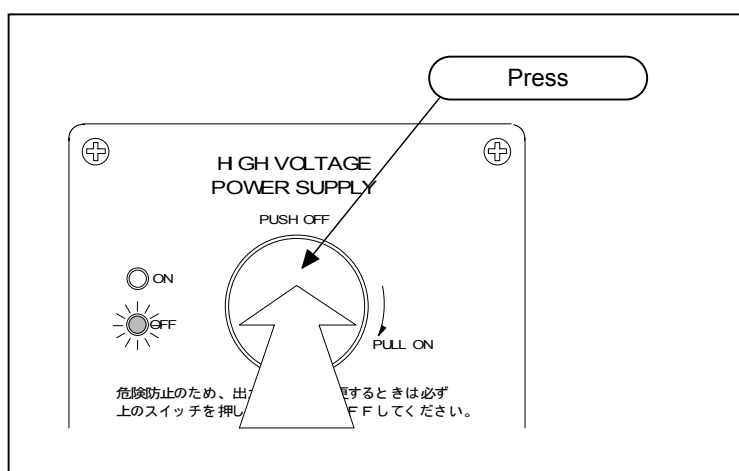

Figure4-68. Internal high voltage power supply OFF

4.5 Change of load and power OFF

c) Power OFF

Check the following points before the POWER is OFF.

- The ON LED of HIGH VOLTAGE POWER SUPPLY is OFF and the OFF LED is ON.
- ALL high voltage output display LEDs are OFF.
- The voltage monitor output is almost 0V.

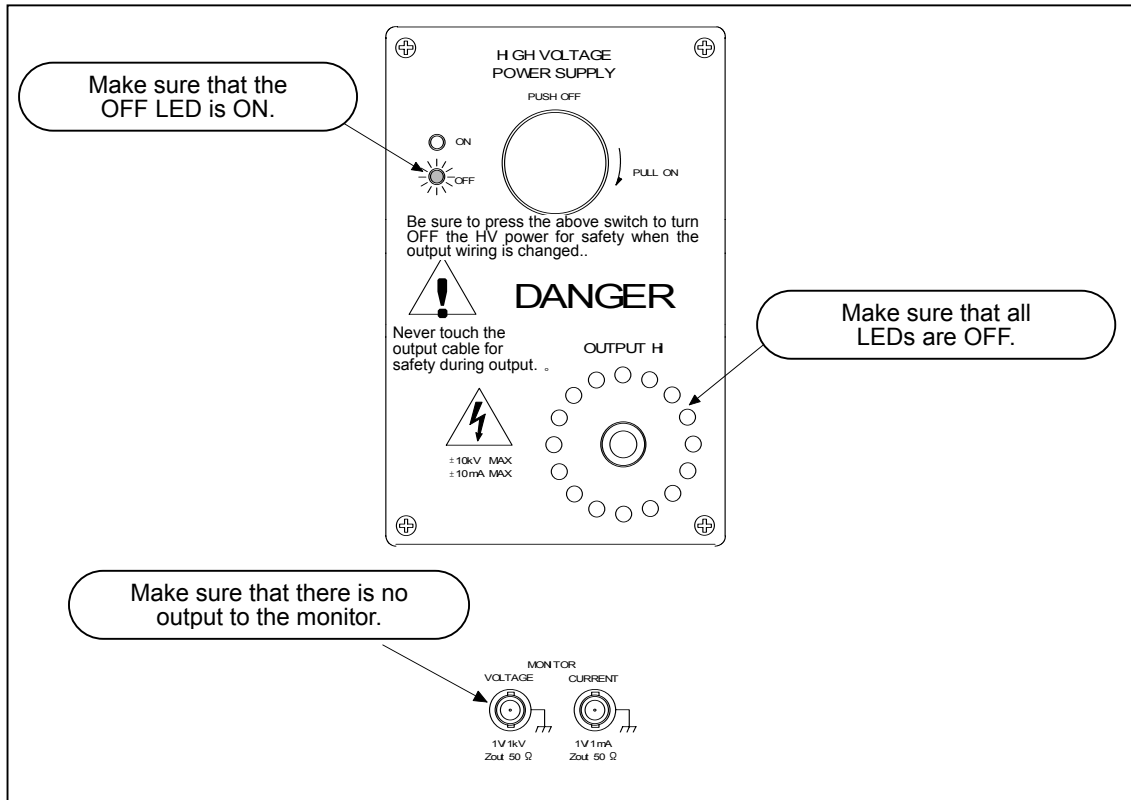

Figure4-69. Checking items before power OFF

After checking items above, turn OFF the POWER.

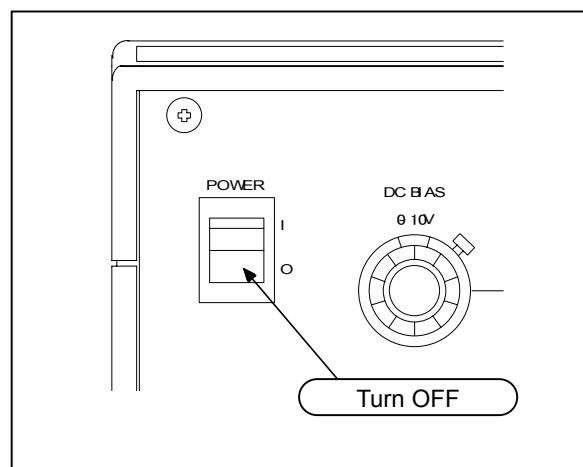

Figure4-70. POWER OFF

⚠ WARNING

If a DC signal is amplified, the load or the high voltage cable is charged with high voltage. It takes time to discharge electricity after POWER OFF. There may be risk of electric shock for a while.

Never touch the high voltage areas such as output terminal area, load, high voltage cable, etc.

d) Change of load

30 seconds or more after turning OFF the POWER, change the load.

During change of the load, remove the high voltage cable connector from the OUTPUT Hi terminal for safety.

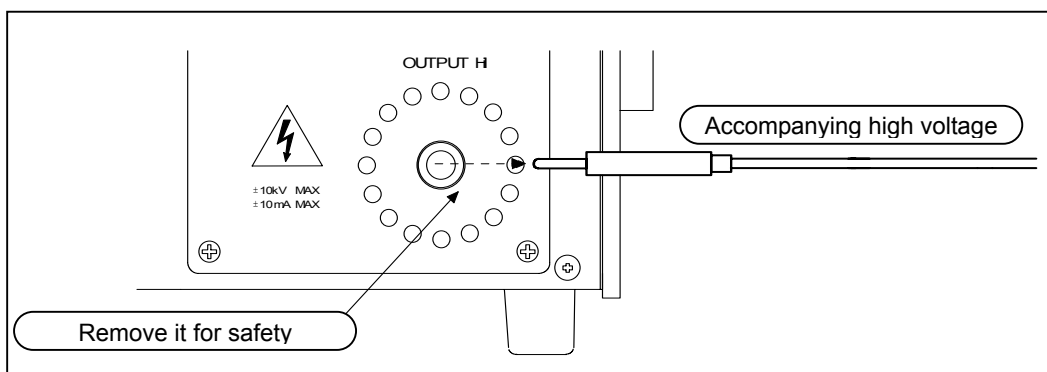

Figure4-71. Removing high voltage cable

After change of the load, be sure to insert the high voltage cable into the connector.

e) Re-supply

Make sure again that connections are safe. Turn ON the POWER.

4.5.2 Power supply OFF

The procedure from end of work to turning the power OFF is the same as "4.5.1 Change of load".

 WARNING

Do not turn OFF the POWER switch with HIGH VOLTAGE POWER SUPPLY ON. Approximately 200V output may be generated.

Be sure to turn OFF HIGH VOLTAGE POWER SUPPLY first before POWER OFF.

However, this does not apply to emergency. Turn OFF the POWER immediately.

4.6 Remote control

4.6.1 Remote control

When the unit is used on a rack or when it is difficult to perform operation on the panel for safety of an operator, a part of the panel can be operated in remote control mode.

In remote control mode, the following operations are available.

HIGH VOLTAGE POWER SUPPLY ON/OFF

ON/OFF of internal DC high voltage power supply

SIGNAL ON/OFF

Signal input ON/OFF to amplifier

OSC INPUT ON/OFF

Signal ON/OFF to external oscillator

INT DC BIAS ON/OFF

Internal DC bias signal ON/OFF

EXT DC BIAS ON/OFF

External DC bias signal ON/OFF

TTL level logic signal and contact signal can be used as control signal.

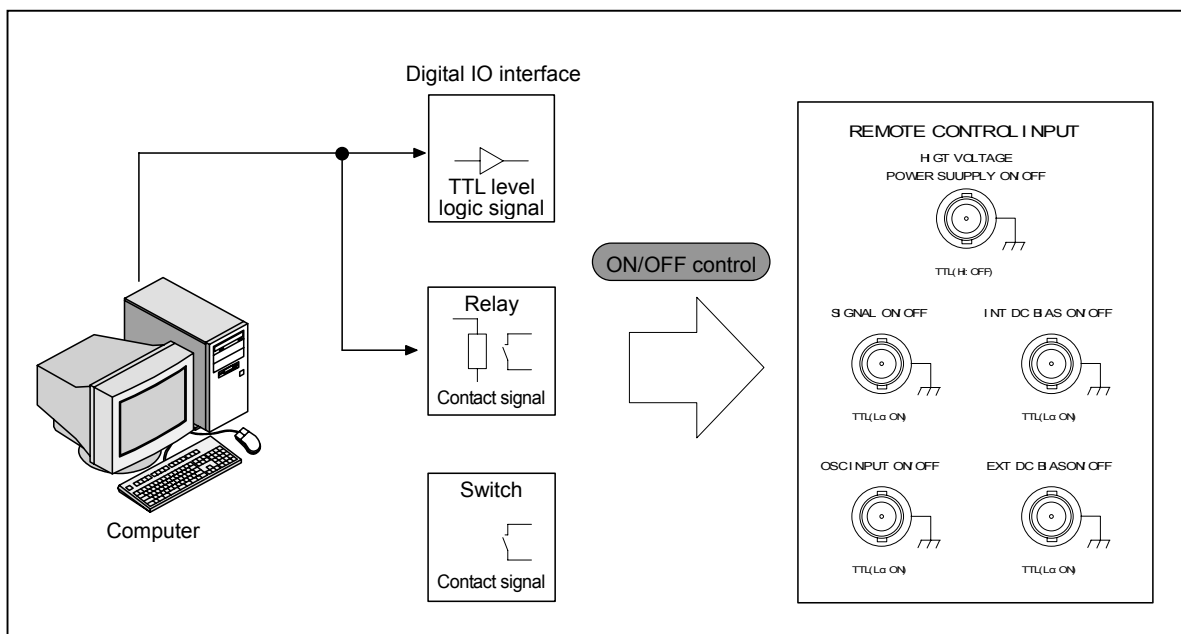

Figure4-72. Remote control

4.6.2 Panel setting for use of remote control

Set the ON/OFF CONTROL switch on the front panel to REMOTE.

When the switch is set to REMOTE, LEDs of DC BIAS ON/OFF, OSC INPUT ON/OFF and EXT DC BIAS INPUT ON/OFF switches go off regardless of ON/OFF status of these switches, indicating that the switching function is invalid.

If this operation is performed while SIGNAL is ON, it is forcedly OFF.

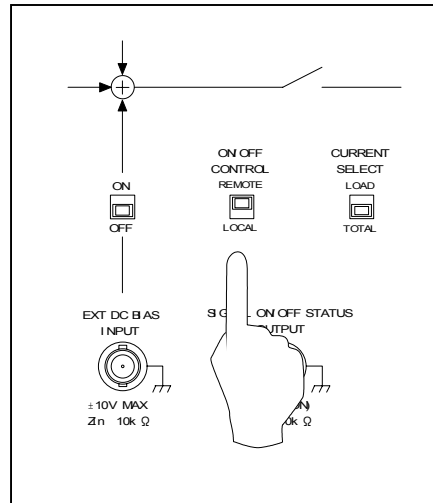

Figure4-73. Remote control switch

4.6.3 Connection of control signal

Connect the control signal to the BNC connector at the back. TTL level logic signal and contact signal can be used as control signal.

- OFF : Hi (TTL level: Positive logic)
Open (Contact signal)
- ON : Lo (TTL level: Positive logic)
Close (Contact signal)

When only the HIGH VOLTAGE POWER SUPPLY ON/OFF switch at the front panel is ON and when the HIGH VOLTAGE POWER SUPPLY ON/OFF signal at the back panel is ON, the internal high voltage DC power supply is ON.

5. Representative characteristics

5.1	Measuring method	5-1
5.2	Characteristics in constant voltage mode	5-3
5.2.1	Frequency characteristics	5-3
5.2.2	Step response	5-4
5.3	Characteristics in constant current mode	5-5
5.3.1	Frequency characteristics	5-5
5.3.2	Step response	5-6
5.4	Characteristics in constant current and constant voltage mode	5-7
5.4.1	Frequency characteristics	5-7
5.5	Characteristics of voltage monitor and current monitor	5-8
5.5.1	Frequency characteristics	5-8
5.6	Others	5-9
5.6.1	Delay of output signal for input signal	5-9
5.6.2	Step response due to difference of amplitude	5-10

5.1 Measuring method

■ Measuring method of output voltage

Measure the output voltage with the high voltage probe (P6015A by Tektronix). To measure frequency characteristics, compensate the frequency characteristics of the high voltage probe using equalizing function of the frequency characteristic analyzer (FRA5095 by NF Circuit Design Block).

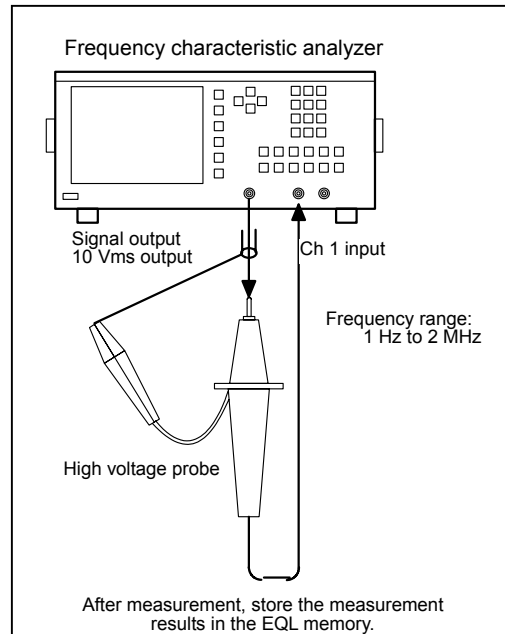

Figure5-1. Compensation of probe

The measuring method of frequency characteristics for output voltage and voltage monitor is as shown in the figure below.

Connect load as required. Take measurements with the load cable length of approx. 15 cm for resistance load and with the load cable length of approx. 5 cm for capacity load.

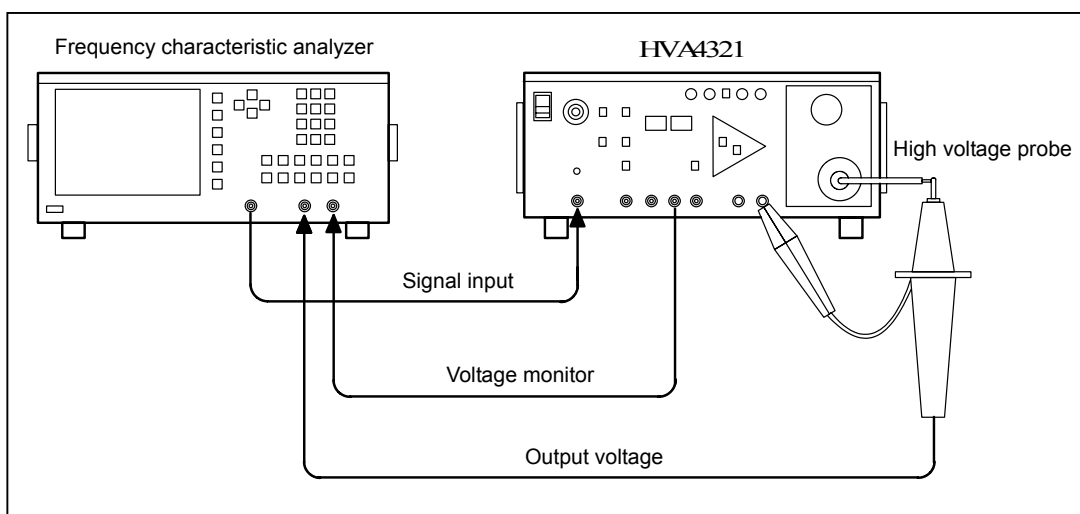

Figure5-2. Measuring method of output voltage

5.1 Measuring method

■ Measuring method of output current

The measuring method of frequency characteristics for output voltage and voltage monitor is as shown in the figure below. For output current, measure voltage at both ends of the current detection resistance.

Connect load as required. Take measurements with the load cable length of approx. 15 cm for resistance load and with the load cable length of approx. 5 cm for capacity load.

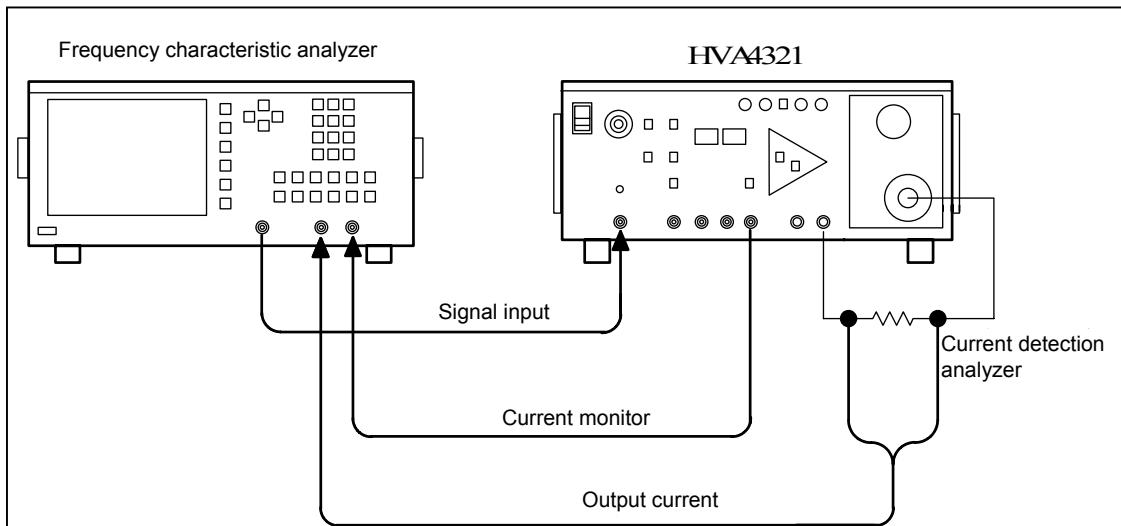

Figure5-3. Measuring method of output current

Representative characteristics are shown on the following pages. However, these do not assure the performance. Use them as reference data.

Scale of frequency characteristics

Output voltage

Since the gain of the high voltage probe is 1/1000 (-60 dB), 0 dB line on the diagram is actually 60 dB.

Output current

The current detection resistance is 1 k Ω

5.2 Characteristics in constant voltage mode

5.2.1 Frequency characteristics

- Frequency characteristics of output voltage in constant voltage mode without load

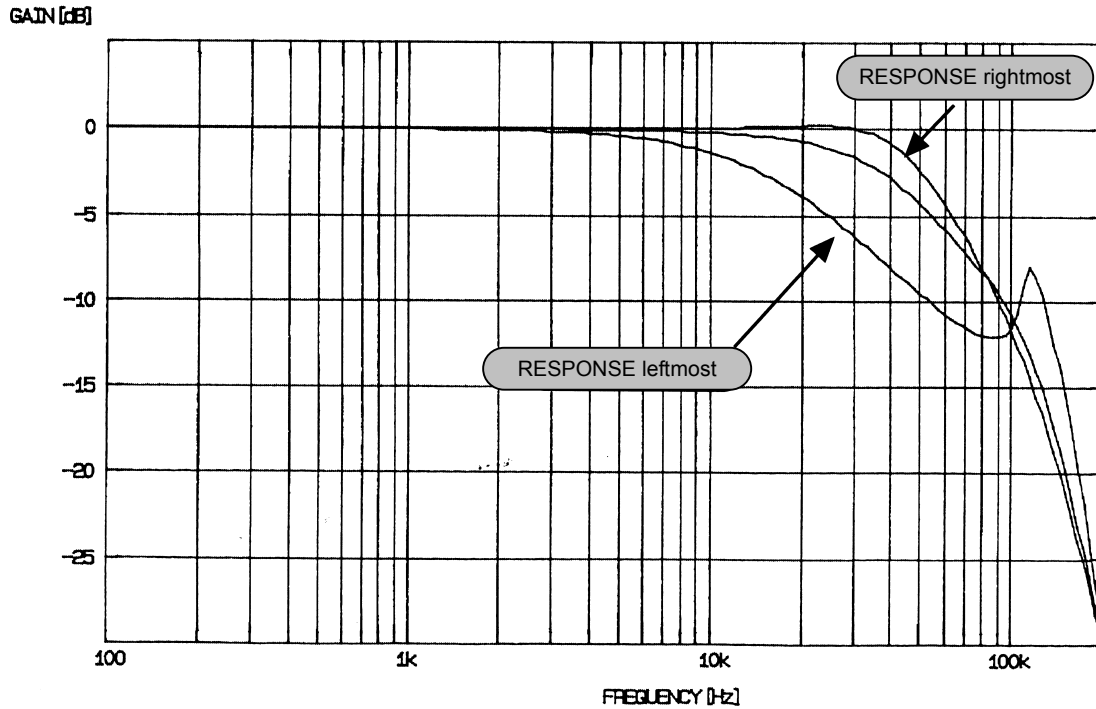

Figure5-4. Frequency characteristics in constant voltage mode without load

- Frequency characteristics of output voltage in constant voltage mode with 35 pF capacity load

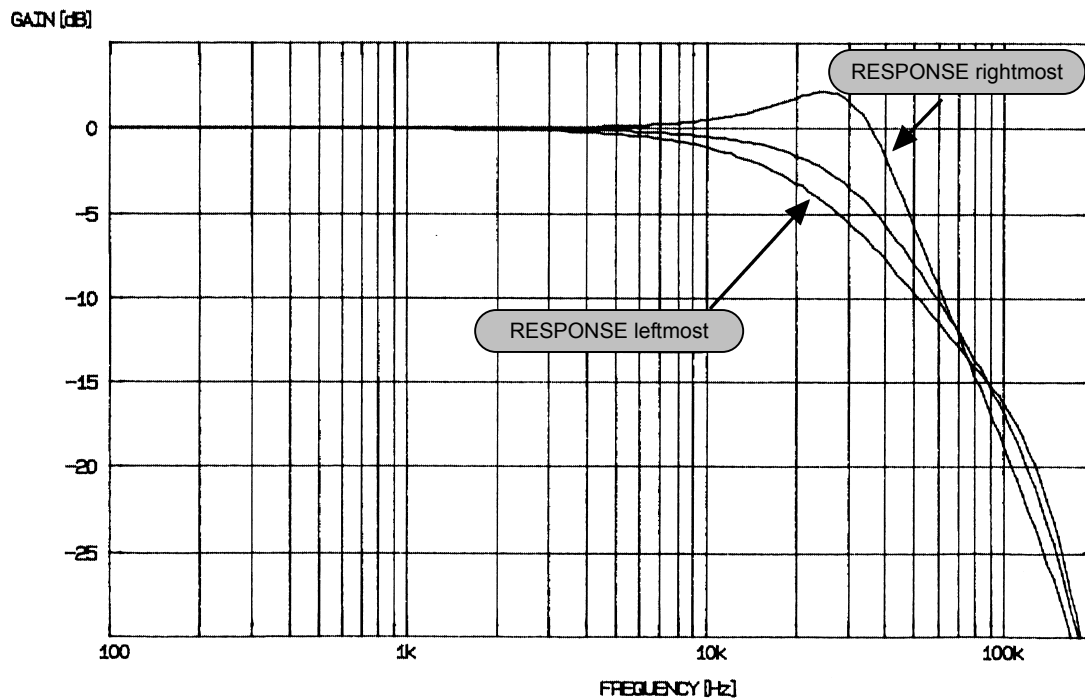
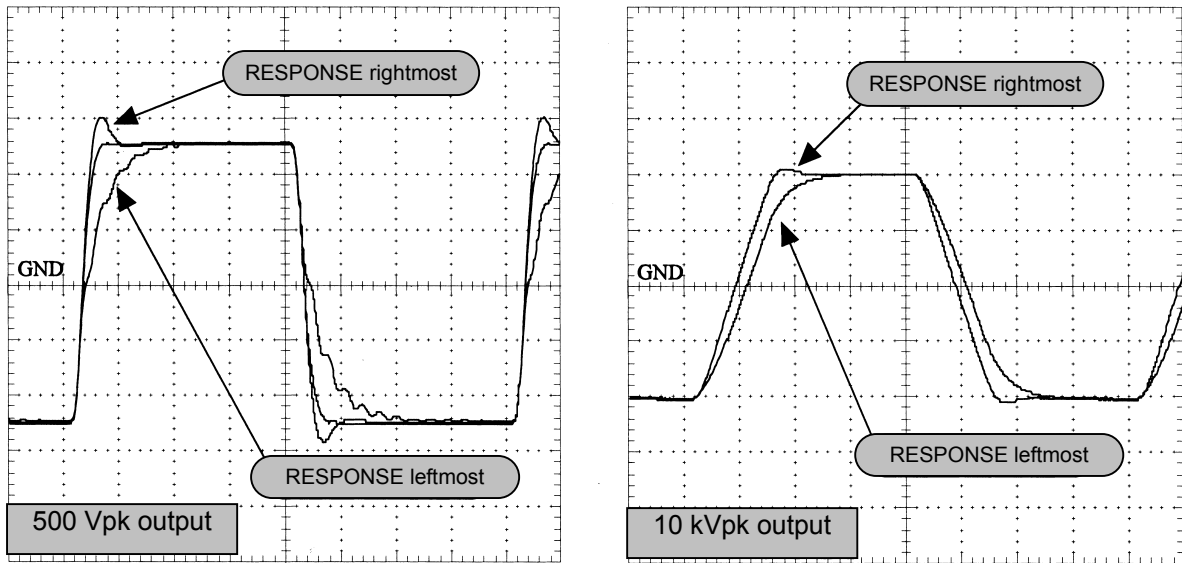

Figure5-5. Frequency characteristics in constant voltage mode with capacity load

5.2.2 Step response

- Step response in constant voltage mode without load. Measure the voltage monitor.



Horizontal axis: 25 Ω /div Vertical axis: 100 V/div (left) 5 kV/div (right)
Figure5-6. Step response in constant voltage mode without load

- Step response in constant voltage mode with 35 pF capacity load. Measure the voltage monitor.

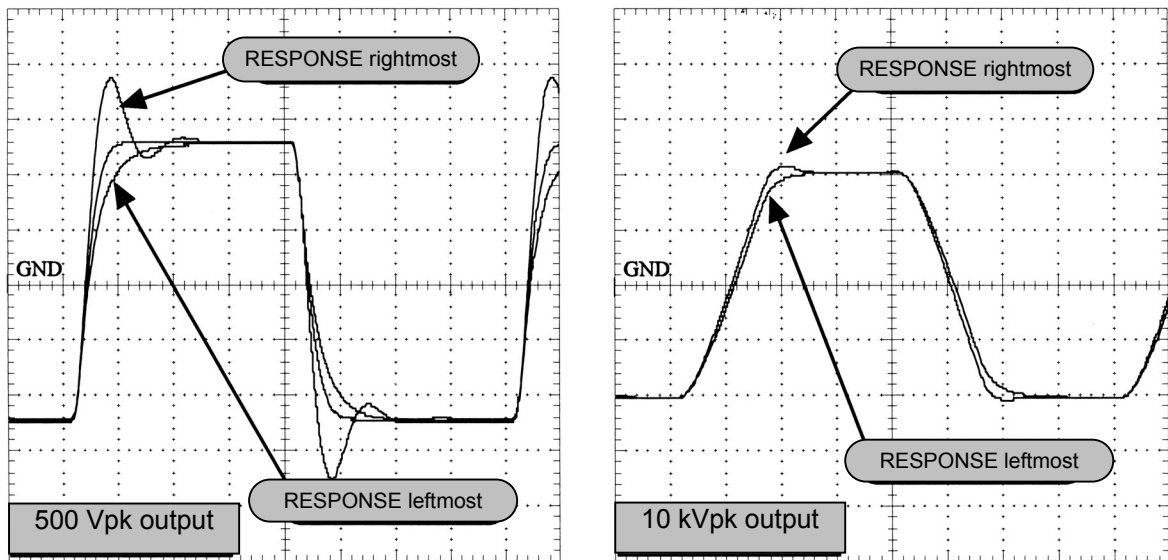

Horizontal axis: 25 Ω /div Vertical axis: 100 V/div (left) 5 kV/div (right)
Figure5-7. Step response in constant voltage mode with 35 pF load

5.3 Characteristics in constant current mode

5.3.1 Frequency characteristics

- Frequency characteristics of output current for input voltage in constant current (TOTAL) mode with short-circuit and resistance load

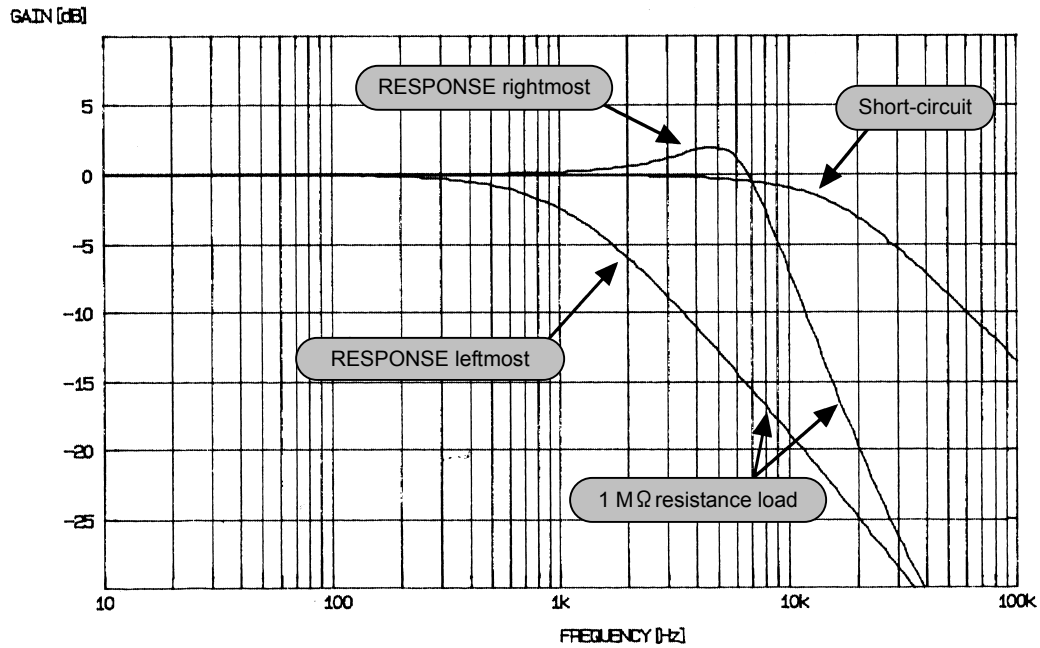

Figure5-8. Frequency characteristics in constant current (TOTAL) mode

- Frequency characteristics of output current for input voltage in constant current (LOAD) mode with short-circuit and resistance load

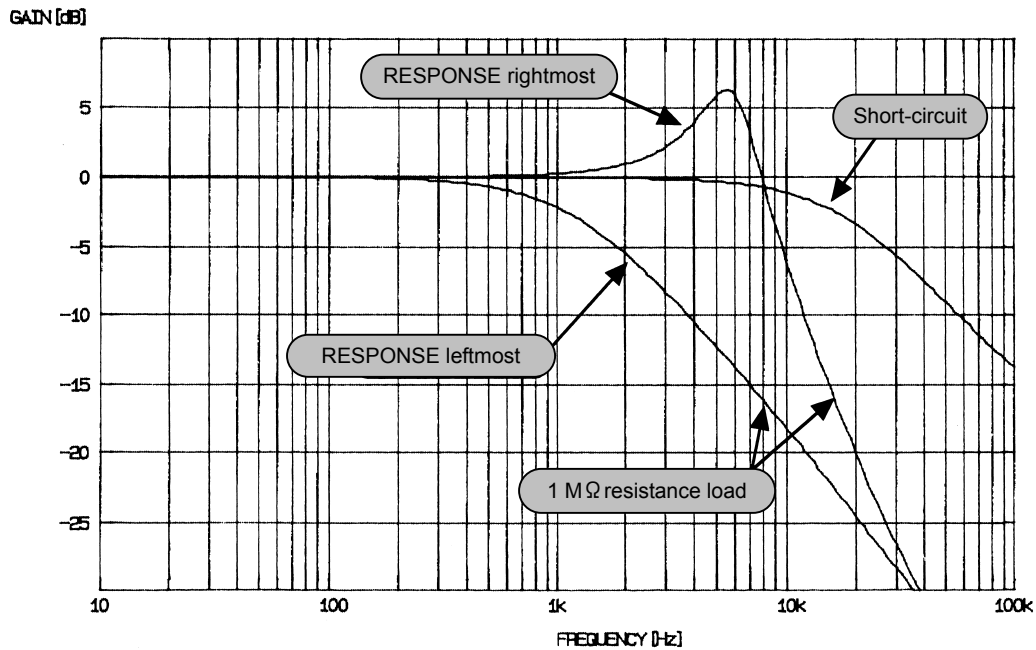
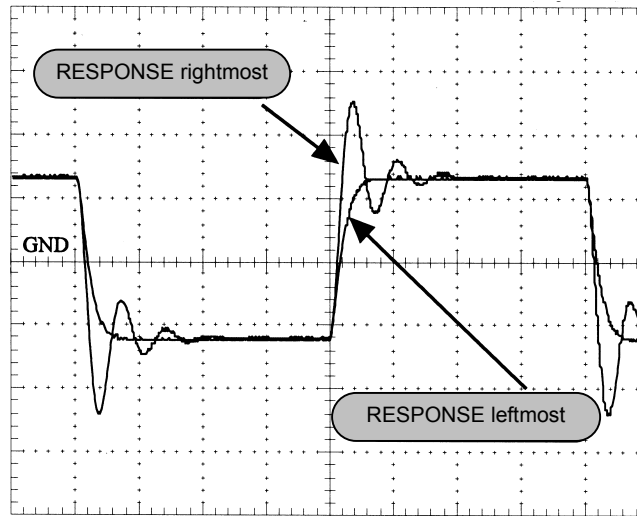

Figure5-9. Frequency characteristics in constant current (LOAD) mode

5.3.2 Step response

- Step response in constant current (TOTAL) mode with $1\text{ M}\Omega$ resistance load. Measure the current monitor.



Horizontal axis: $250\ \Omega/\text{div}$ Vertical axis: $200\ \text{mV}/\text{div}$
Figure5-10. Step response in constant current mode with $1\ \text{M}\Omega$ load

5.4 Characteristics in constant current and constant voltage mode

5.4.1 Frequency characteristics

- Frequency characteristics of output current for input voltage in constant current (TOTAL) + constant voltage mode with capacity load

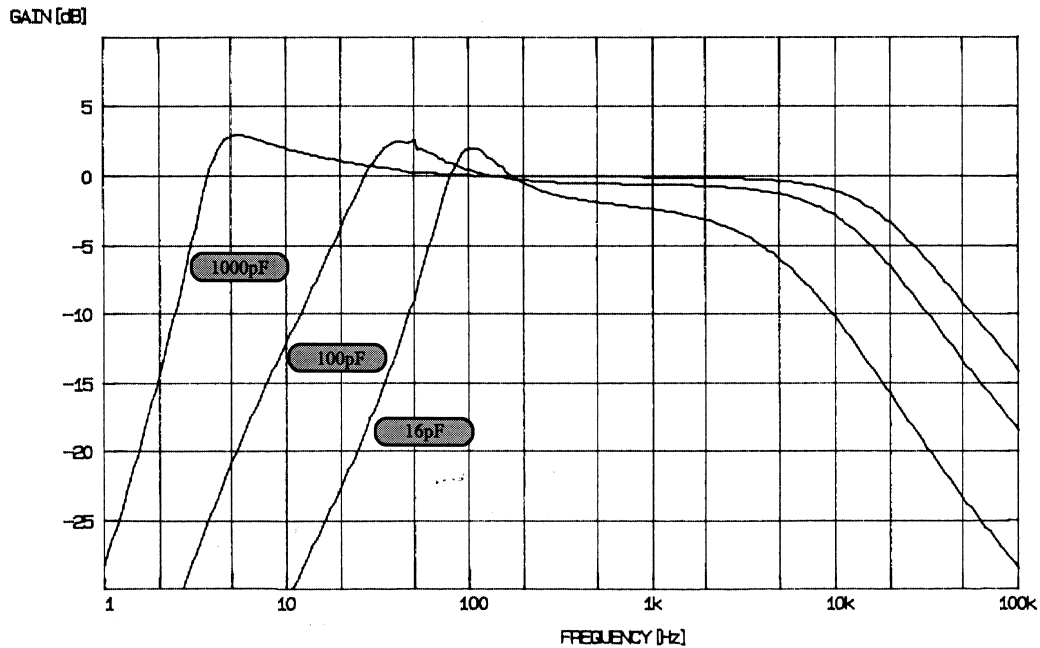

Figure5-11. Frequency characteristics in constant current (TOTAL) + constant voltage mode

- Frequency characteristics of output current for input voltage in constant current (LOAD) + constant voltage mode with capacity load

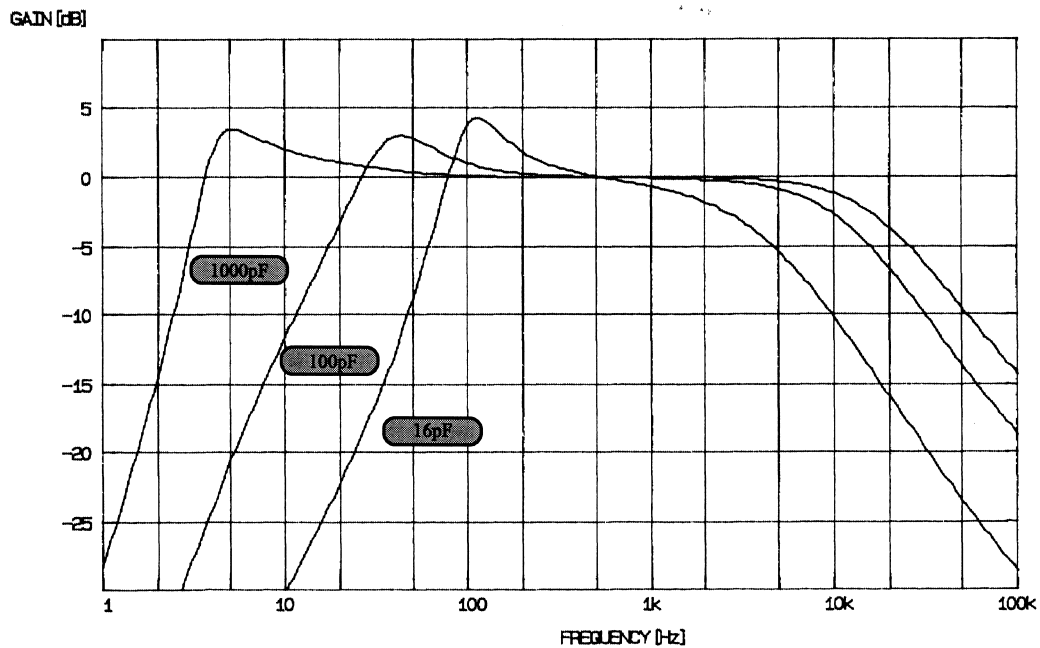

Figure5-12. Frequency characteristics in constant current (LOAD) + constant voltage mode

5.5 Characteristics of voltage monitor and current monitor

5.5.1 Frequency characteristics

- Frequency characteristics of voltage monitor (10 kVpk output without load)

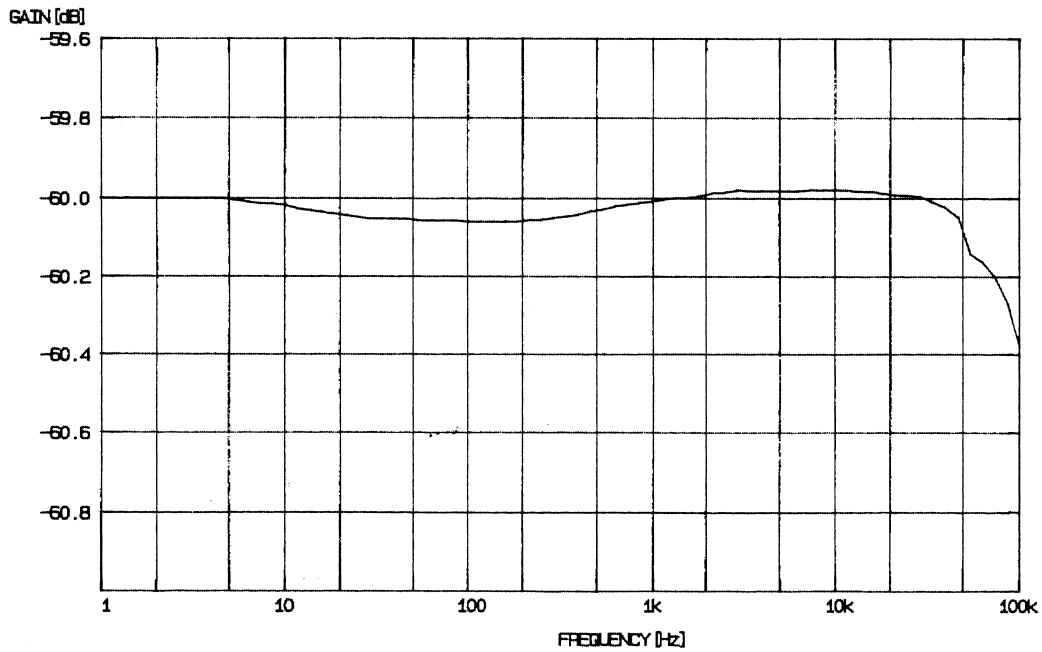

Figure5-13. Frequency characteristics of voltage monitor

- Frequency characteristics of current monitor (10 mApk output with short-circuit)

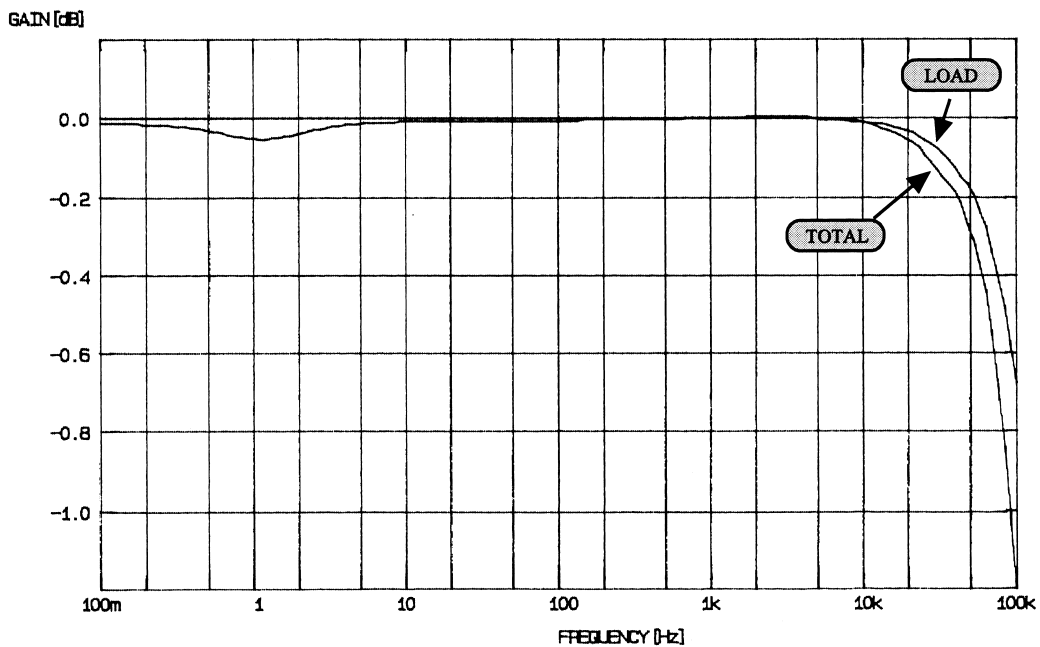
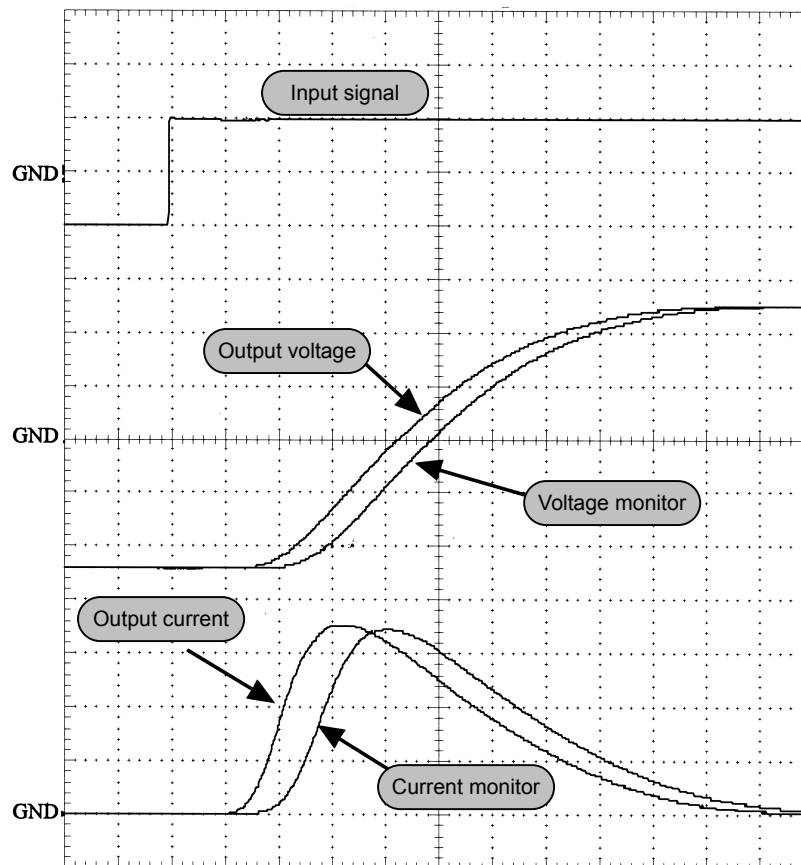

Figure5-14. Frequency characteristics of current monitor

5.6 Others

5.6.1 Delay of output signal for input signal

- Delay of output signal for input signal (5 kVpk output with 16 pF capacity load)



Horizontal axis: 2 Ω /div Vertical axis: Input voltage 5 V/div
 Output voltage 2 kV/div
 Voltage monitor 2 V/div
 Output current 500 μ A/div
 Current monitor 50 mV/div

Figure5-15. Delay of input/output signal

- Output signal rises later by approx. 4 Ω than input signal.

5.6.2 Step response due to difference of amplitude

- Step response difference due to difference of amplitude (Constant voltage mode without load. Measure the voltage monitor.)

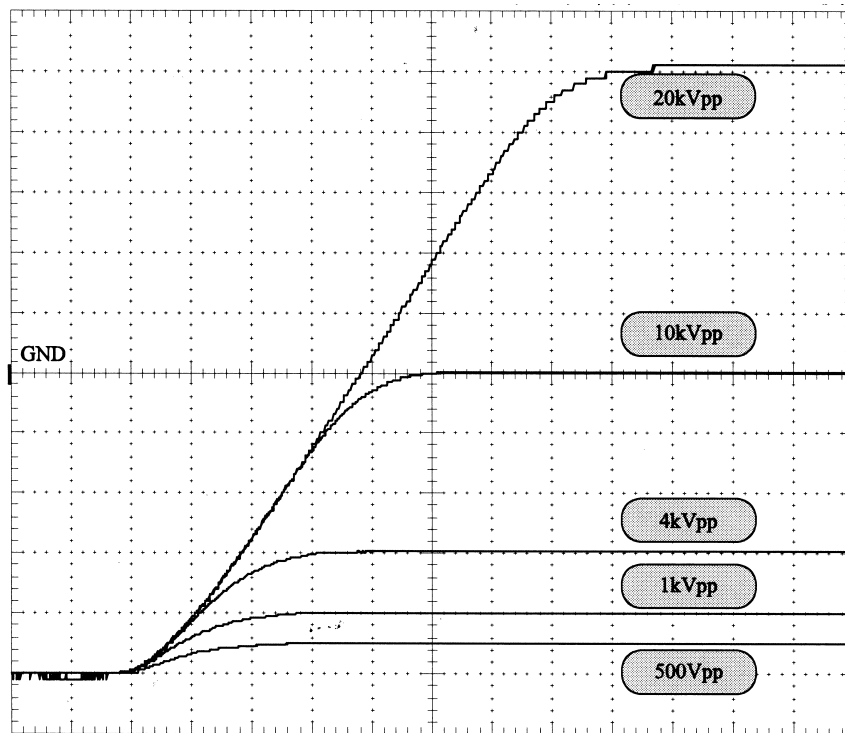

Horizontal axis: 5 μ s/div Vertical axis: 2 V/div

Figure5-16. Step response in constant voltage mode

- The rising time up to 4 kVpk is constant regardless of the amplitude.
- The time over the value above is limited by slew rate.

6. Troubleshooting

6.1	When suspecting a fault	6-1
-----	-------------------------------	-----

6.1 When suspecting a fault

If you suspect a fault like operation against expectation or strange operation, refer to the check list below. Check for handling, operation method and connection. Before check, turn OFF the power switch

■ When the power is supplied

Problem	Cause	Action
Power is not ON.	Is the power supplied?	Make sure that the power is correctly supplied.
	Is the fuse blown?	Replace the fuse.

■ When the internal high voltage DC power supply is ON

Problem	Cause	Action
SIGNAL OFF remains blinking.	Is the shorting plug at the back inserted?	Insert the shorting plug.
	Is the current limiter set to the minimum or TRIP?	Increase the limiter set value or change TRIP to LIMIT.
	When the installation space for this unit has high temperature or when the unit is used at a high output for a long time, the temperature sensor in this unit may activate a protection mode.	Lower the temperature of the installation area or leave the unit at a cool place for cooling.
	If the cooling fan stops for some reason, the unit automatically goes to protection mode for safety.	If the cooling fan stops, stop operation immediately and contact us.
When the HIGH VOLTAGE POWER SUPPLY switch is OFF, the HVPS ON LED lights.	The internal high voltage DC power supply may be faulty.	Stop operation immediately and contact us.

6.1 When suspecting a fault

■ When SIGNAL is OFF

Problem	Cause	Action
The output warning lamp lights despite SIGNAL OFF.	The output warning lamp of this unit may light depending on the load conditions or response settings.	Change the response settings. Check the output monitor with an oscilloscope and check if there is any oscillation.
	In constant current mode, the output warning lamp may light when the voltage limit is set to a large difference between positive and negative values.	Set the positive and negative voltage limit values to the same level as much as possible.
	Is the output open in constant current mode?	Be sure to connect the load.

■ When SIGNAL is ON

Problem	Cause	Action
Unexpected high voltage output is given in constant current mode.	Is the load correctly connected?	Make sure that the connection to the load is correct.
Unexpected high voltage output is given in constant current mode or LOAD mode.	Is the load connected to the TOTAL terminal?	Connect the load to the LOAD terminal correctly.
	Is the load grounded?	Do not ground the load.
When the output is short-circuited in constant current + constant voltage mode, over-current occurs.	DC bias operates at constant voltage in constant current + constant voltage mode.	Do not short-circuit the output in constant current + constant voltage mode.
When the current limiter is activated for capacity load, peak current increases.	When voltage becomes non-linear due to activation of the current protection circuit, peak current may increase.	Increase the current limit setting.
When capacity load is connected in constant current mode, ham occurs.	In the low frequency range, the capacity load is a large impedance.	If it is a problem, use the unit in load mode. The ham may be decreased.

If any of the check items above is not applicable or corrective actions described do not improve status, take measures to prevent supply of the power by attaching a paper to this unit indicating "Not for use". Then, contact us or your sales agent you purchases.

7. Maintenance

7.1	Daily maintenance	7-1
7.2	Inspection	7-2
7.3	When the unit is not used for a long time	7-2
7.4	Performance test	7-3
7.4.1	Test of constant voltage mode	7-3
7.4.2	Test of constant current mode	7-4

7.1 Daily maintenance

WARNING

Be sure to perform maintenance while the power cable is removed from the outlet.

- If the panel or the case is dirty, clean with a soft cloth. If it is heavily dirty, clean with a cloth soaked in neutral detergent and wring it tightly.
- Cleaning with volatile solvent such as thinner and benzene or a chemical wipe may cause deterioration or peel of paint. Never use it.
- The intake cooling fan (the fan in the left when viewed from the back) at the back of the unit is provided with an air filter to remove dust in the intake air. Clean the air filter regularly to prevent temperature rise in the unit due to clogging.

The air filter may be removed by unlocking the locks at the upper, lower, left and right sides of the fan cover at the back of the unit and by pulling out.

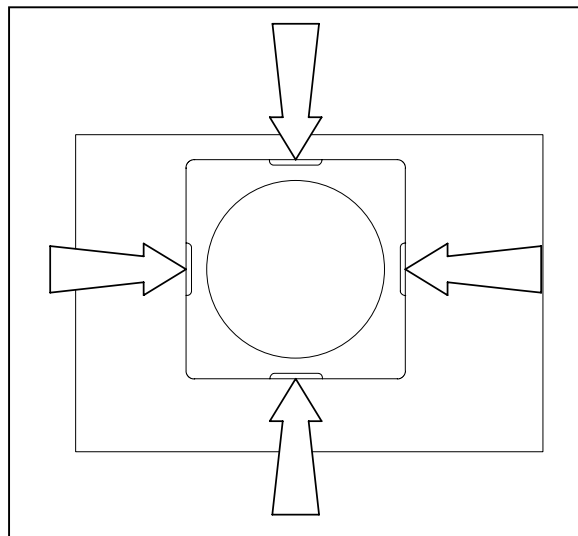

Figure7-1. How to remove fan cover

7.2 Inspection

For cleaning the air filter, remove dirt completely with diluted neutral detergent. After rinsing, dry the filter completely and install it on the unit.



CAUTION

Clean the air filter regularly. Clogging of the filter deteriorates cooling efficiency and may cause a failure.

7.2 Inspection

- | | |
|----------------------|--|
| • Power cable | Check for broken shield, or looseness or crack of the plug. |
| • High voltage cable | Check for broken shield, or split or crack of the connector. Be sure to use the accompanying high voltage cable for connection to the output terminal. |
| • Front area | Make sure that the HIGH VOLTAGE POWER SUPPLY switch can be locked. |



WARNING

A cable with broken shield or disconnected wire may cause electric shock. Do not use such cable.

7.3 When the unit is not used for a long time

- Remove the power cable from the outlet and the unit.
- Store the unit in a shelf or rack, free from falling objects and dust.
If the unit may be covered with dust, cover the unit with a cloth or a polyethylene cover.
- Avoid storage at a place subject to extreme temperature change or direct sunlight. Store the unit in the environment at normal temperature.

7.4 Performance test

This section describes a simple performance test of the unit.

7.4.1 Test of constant voltage mode

The gain accuracy and the monitor accuracy when the standard signal input is given in constant voltage mode are checked.

Give voltage input from the reference DC power supply to the external DC bias signal input. Make sure that the output is +10 kV for +10V input.

Make sure that the error between the actual output and the value of the output monitor is 0.3% or less.

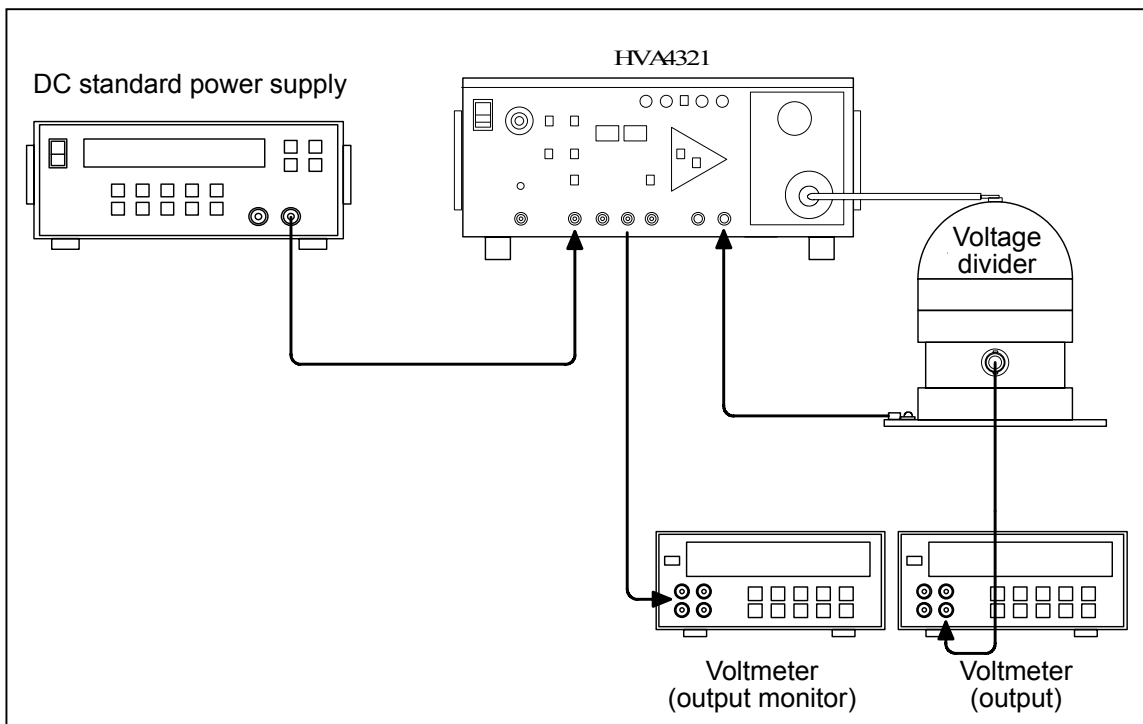

Figure7-2. Check method of constant voltage mode

7.4.2 Test of constant current mode

The gain accuracy and the monitor accuracy when the standard signal input is given in constant current mode are checked.

Given voltage input from the standard DC power supply to the external DC bias signal input. Make sure that the output is +10 mA for +10V input.

Make sure that the error between the actual output and the value of the output monitor is 0.5% or less.

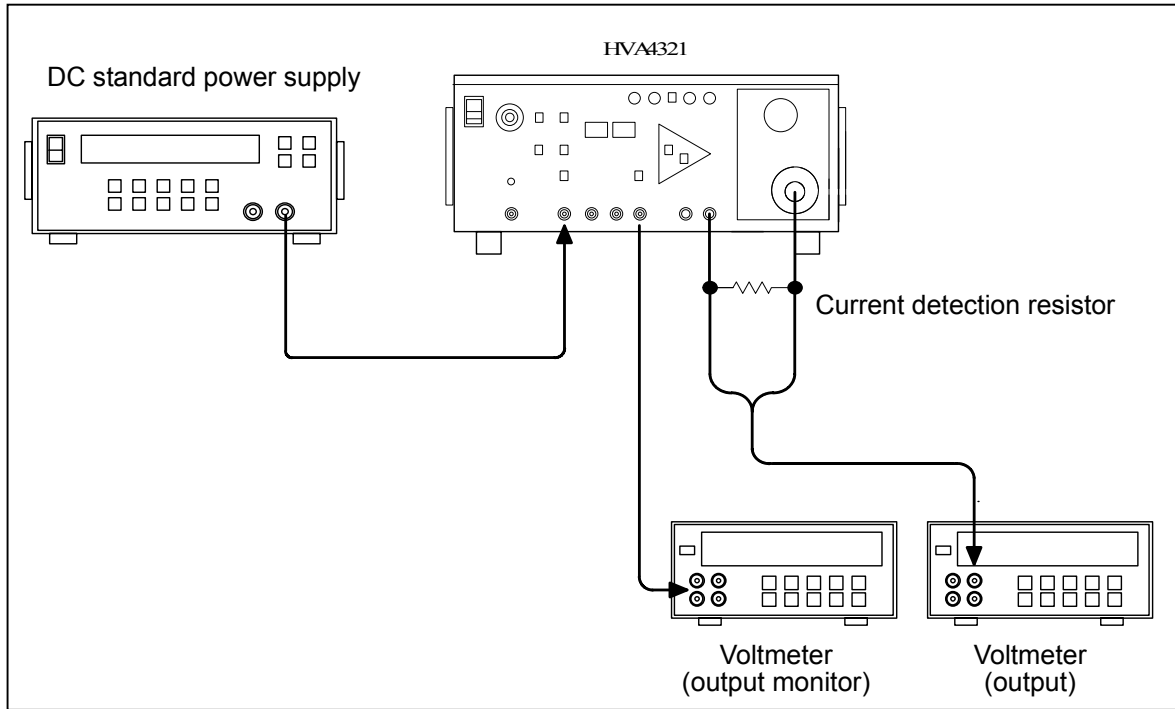

Figure7-3. Check method of constant current mode

8. Specification

8.1	Signal area	8-1
8.2	Amplifier	8-2
8.2.1	Characteristics of constant voltage mode	8-2
8.2.2	Characteristics of constant current mode	8-4
8.3	Output area	8-6
8.4	Monitor output	8-6
8.5	Other input/output signal	8-7
8.6	Protection circuit	8-8
8.7	Others	8-8
8.8	General items	8-9

8.1 Signal area

Unless otherwise specified, the listed values are at no load (open-circuit in constant voltage mode and short-circuit in constant current mode).

■ Internal signal source for DC bias

Output adjustment range	In constant voltage mode: Equivalent to the output voltage range from 0 V to ± 10 kV.
	In constant current mode: Equivalent to the output current range from 0 mA to ± 10 mA. With 10 rotation potentiometer
Inversion function:	Available
Signal ON/OFF function	Available (ON/OFF with external signal is also available.)

■ Signal input for oscillator

Input voltage range	± 10 Vpk
Input terminal	BNC
Input resistance	$10\text{ k}\Omega \pm 10\%$
Gain adjustment range	$\pm 3\%$ (Continuously variable with semi-fixed regulator)
Inversion function	Available
Signal ON/OFF function	Available (ON/OFF with external signal is also available.)

■ Signal input for DC bias

Input voltage range	± 10 Vpk
Input terminal	BNC
Input resistance	$10\text{ k}\Omega \pm 10\%$
Signal ON/OFF function	Available (ON/OFF with external signal is also available.)
Polarity	Same phase as the output

8.2 Amplifier

8.2.1 Characteristics of constant voltage mode

- Amplifier gain
1000 V/1 V (60 dB)
- Gain accuracy when external signal source for DC bias is used
 $\pm 0.3\%$ of full scale
- Gain temperature drift
 ± 100 ppm/ \square typ
- Rated load
 - Resistance load 1000 k Ω
 - Capacity load 35 pF (including output cable capacity)
- Maximum output voltage
 ± 10 kVpk (for DC+AC)
- Maximum output current
 - Average current ± 10 mA (for DC+AC)
 - Pulse peak current ± 60 mA or more

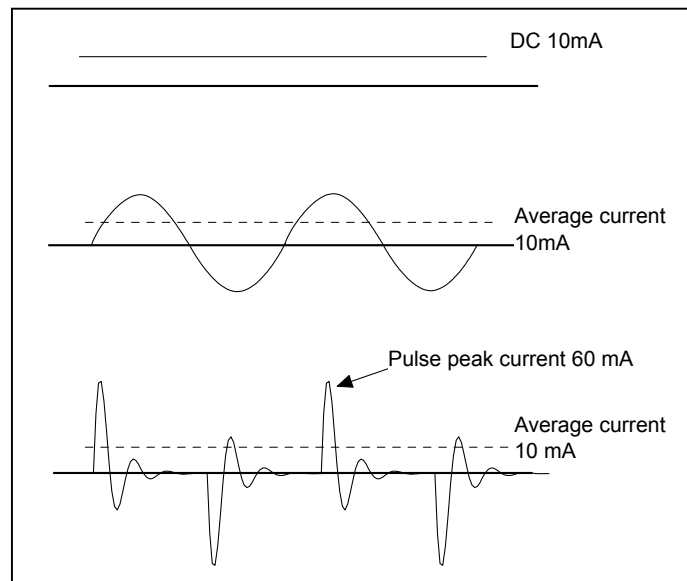

Figure8-1. Output current

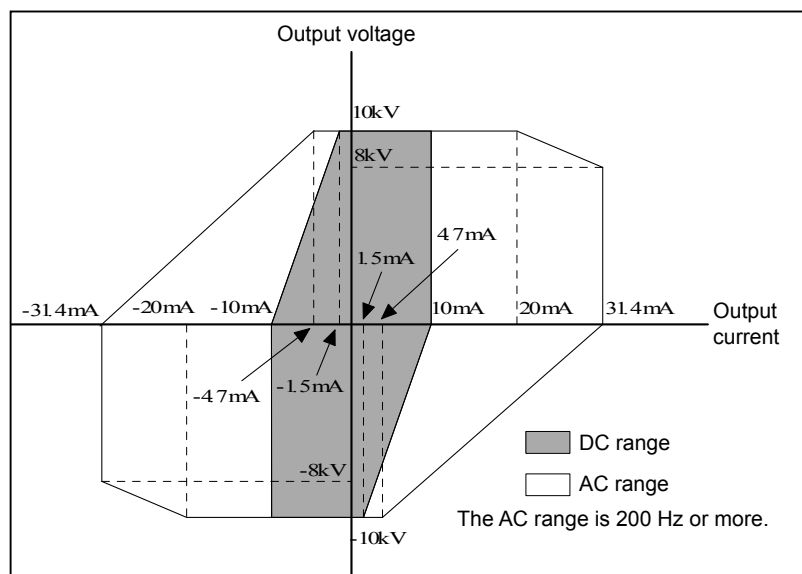

Figure8-2. Voltage and current range allowed for output

■ Frequency characteristics

Major amplitude characteristics

DC: Up to 7 kHz

Frequency range allowed for 10 kVpk output

Measured with a high voltage probe (Model P6015A by Tektronix), with connection to the rated resistance load, load connection cable of 10 cm or less, and with the RESPONSE dial turned rightmost.

Minor amplitude characteristics

DC: Up to 45 kHz ± 3 dB

Measured with a high voltage probe (Model P6015A by Tektronix) without load, with 1 kVpk output, and with the RESPONSE dial turned rightmost.

■ Slew rate

500 V/ Ω or more

Measured with a high voltage probe (Model P6015A by Tektronix), with 10kVpk output and with the RESPONSE dial turned rightmost.

■ Output residual noise

500 mVrms or less

At 0V output, the output terminal is measured with the RMS value AC voltmeter M-170 (by NF Corporation, bandwidth of 20 MHz) or its equivalent.

■ Output offset voltage

± 20 V

When the ON/OFF switch of each signal source is OFF and the signal ON/OFF switch is ON.

8.2.2 Characteristics of constant current mode

- Amplifier gain
1 mA/1V
- Gain accuracy when the external signal source for DC bias is used
±0.5 % of full scale
- Gain temperature drift
±250 ppm/□typ
- Maximum output current
±10 mA_{pk} (for DC+AC)
- Maximum output voltage
±10 kV_{pk} (for DC+AC)
- Rated load
Resistance load: 1000 kΩ
- Frequency characteristics
 - Major amplitude characteristics
DC: Up to 4 kHz
Frequency range allowed for 10 mA_{pk} output
Measured with a high voltage probe (Model P6015A by Tektronix) with rated resistance load, with load connection cable of 10 cm or less, and with the RESPONSE dial turned rightmost.
 - Minor amplitude characteristics
DC: Up to 10 kHz ±3 dB
(short-circuit for 10 mA_{pk} output)
- Slew rate
1 mA/μs or more
- Output residual noise
500 μA rms or less
Measured with the RMS value AC voltmeter M-170 (by NF Corporation, bandwidth of 20 MHz) or its equivalent
- Output offset current
±50 μA
- DC superimposing function
By setting the DC BIAS, the DC component may be operated in constant current mode or in constant voltage mode.
- Remote sensing function of return current
With the remote sensing function, leak current can be ignored and the load current is correctly ignored. However, the maximum average current is up to ±10 mA.

8.3 Output area

- High voltage output Hi terminal (OUTPUT Hi)
Special high voltage jack (Front panel)
(A400B series by ALDEN)
- High voltage output Lo terminal (OUTPUT Lo)
Binding post (Front panel)
(Both for total current terminal and load current terminal)

8.4 Monitor output

- Output voltage monitor

Gain	1/1000 fold
DC gain accuracy	±0.2 % of full scale
Output offset voltage	±20 mV
Output residual noise	2 mVrms or less Measured with the RMS AC voltmeter M-170 (by NF Corporation, bandwidth of 20 MHz) or its equivalent without load at 0V output
Output resistance	50 Ω ±10 %
Terminal	BNC (Front panel)

- Output current monitor

Gain	1V/10 mA
DC gain accuracy	±0.5 % of full scale
Output offset voltage	±3 mV When high voltage output is given
Output residual noise	3 mVrms or less Measured with the RMS AC voltmeter M-170 (by NF Corporation, bandwidth of 20 MHz) or its equivalent when high-voltage output is given
Output resistance	50 Ω ±10 %
Terminal	BNC (Front panel)

8.5 Other input/output signal

■ Remote control signal input (REMOTE CONTROL INPUT)

Function	ON/OFF of internal signal source for DC bias, signal input for oscillator and external signal input for DC bias; and Batch ON/OFF (SIGNAL ON/OFF) of the above signals
Input	Depends on TTL level signal or contact signal. Lo or short-circuit : ON Hi or open : OFF
Input method	BNC (Back panel)

■ Internal high voltage DC power supply ON/OFF signal input (HIGH VOLTAGE POWER SUPPLY ON/OFF)

Function	ON/OFF of internal high voltage DC power supply (When it is OFF, SIGNAL is also OFF.)
Input	Depends on TTL level signal or contact signal. Lo or short-circuit : ON Hi or open : OFF
Input method	BNC (Back panel) BNC for short-circuit is accompanied.

■ ON/OFF status contact output (SIGNAL ON/OFF STATUS)

Function	Contact output linked to the ON/OFF status of the signal
Contact rating	Max. AC 250 V 3A or DC 30 V 3A
Output method	Contact C M3 screw, 4P terminal table (back panel)

■ ON/OFF status signal output (SIGNAL ON/OFF STATUS OUTPUT)

Function	Signal to indicate the ON/OFF status of the signal
Output	TTL level Lo : OFF Hi : ON
Output method	BNC (Front panel)

8.6 Protection circuit

■ Limit of output voltage (VOLTAGE LIMITER)

With the digital switch, the maximum output voltage may be independently set for positive and negative.

This is available in both constant voltage mode and constant current mode. However, the set values are approximate values.

Adjustment range

Positive: Set between +5 kV and +10 kV with increments of 1 kV, or no limit

Negative: Set between -5 kV and -10 kV with increments of 1 kV, or no limit

■ Limit of output current (DC CURRENT LIMITER)

The maximum output current (DC and AC average values) may be set continuously with the regulator.

This is available in both constant voltage mode and constant current mode. However, the set values are approximate values.

If the current exceeds the set value, to limit the output current at the set value or to turn OFF the output may be selected with the switch.

Adjustment range: Continuous variation from 0 to ± 10 mA (Same value setting for positive and negative)

8.7 Others

■ Signal ON/OFF (SIGNAL ON/OFF)

When the SIGNAL switch (or with remote control input) is OFF, the command value for the high voltage amplifier is set to 0V and 0A.

The output circuit and the output terminal of the high voltage amplifier are not disconnected electrically. Since the output circuit and the output terminal of the high voltage amplifier remain connected, to change load or wiring, turn OFF the internal high voltage DC power supply and the power of the unit before work.

■ Internal high voltage DC power supply ON/OFF switch (HIGH VOLTAGE POWER SUPPLY ON/OFF)

This switch turns ON/OFF the output of the internal high voltage DC power supply. The output status of the internal high voltage DC power supply is indicated by LED.

■ High voltage output lamp

During high voltage output, the LED around the output connector rotates and blinks.

The rotation speed varies according to the output voltage. The LED color is orange for approx. 4.9 kVpk or less and red for approx. 4.9 kVpk or more.

■ Adjustment of step response waveform (RESPONSE CV RESPONSE CC)

The step response characteristics may be independently adjusted in constant voltage mode and constant current mode. A semi-fixed regulator is used for adjustment. The adjustment range varies depending on the load condition. In cases, oscillation may occur.

8.8 General items

■ Input/output ground

All signal input/output (BNC connector) excluding the terminal block for ON/OFF status signal contact output, and the total current terminal of the high voltage output terminal (OUTPUT Lo) are connected to the casing.

■ Power supply

Range of power supply voltage	Single phase AC 100 V ±10 %
Frequency of power supply	50 Hz/60 Hz ±2 Hz
Power supply fuse	AC 250V, 10 A, Time lag ϕ 2 x 20 mm
Power consumption	800 VA or less

■ Installation environment of unit

Installation position of unit	Horizontal (10° or less)
Cooling method of the unit	Forced air cooling (Intake from back, exhaust from sides) Sufficient space is provided at the back and sides of the unit not to disturb air cooling function.

■ Environment condition

Performance guarantee	Temperature	+5°C ~ +35°C
	Humidity	10 ~ 85 %RH (No condensation)
Operation guarantee	Temperature	0°C ~ +40°C
	Humidity	10 ~ 85 %RH (No condensation)
Storage	Temperature	-10 °C ~ +50°C
	Humidity	10 ~ 80 %RH (No condensation)

■ Insulation resistance

Power supply input to casing	30 MΩ or more (with DC 500 V)
------------------------------	-------------------------------

■ Voltage resistance

Power supply input to casing	AC 1500 Vrms for 1 minute
------------------------------	---------------------------

■ External dimensions

440 mm (width) x 177 mm (height) x 450 mm (depth) (excluding handle and protrusions)

■ Weight

Approx. 18 kg

WARRANTY

This product is shipped after having undergone full testing and inspection of the NF Corporation.

Should this product fail due to a manufacturing flaw or due to a mishap during shipping, contact NF Corporation or an NF Corporation sales representative.

NF Corporation products purchased either from NF Corporation or from an NF Corporation sales representative are guaranteed for one full year from the date of purchase against defects in material and workmanship.

This warranty entitles you to free repair of the product covered under it as long as you contact either NF Corporation or an NF Corporation sales representative about the problem while the warranty is still valid.

This warranty is valid only in Japan. If planning to use it outside Japan, consult NF Corporation or an NF Corporation sales representative.

In the following cases, repair will be charged even if the warranty is still valid.

- Failure caused by handling or storage that goes against the usage methods and/or cautions described in the instruction manual of the product
- Failure or damage caused by dropping of the product or exposure to shocks by the customer during transportation
- Modification of the product by the customer
- Failure caused by abnormal voltage from external or failure caused by external equipment connected to the product
- Failure or damage caused by natural disaster such as fire, earthquake, flood, lightning, explosion, or war
- Replacement of consumables such as magnetic and tape and battery

ABOUT REPAIR

If a problem occurs and it is judged to be a failure of the product, or if you have questions, contact NF Corporation or an NF Corporation sales representative.

When contacting NF Corporation or an NF Corporation sales representative, provide the model name (or product name), the manufacturing number (serial number shown on the name plate), and information as detailed as possible about the nature of the problem, conditions of use, etc.

NF Corporation is committed to providing repair services as quickly as possible. Note, however, that in the case of products that have been purchased 5 or more years before, several days may be needed in order to procure the needed repair parts.

Also note that if repair parts are no longer manufactured, or in the case of remarkable damage or modification of the product, NF Corporation reserves the right to refuse repair.

IMPORTANT

1. Reproduction of this instruction manual either in part or in whole, is strictly prohibited.
 2. The contents of this instruction manual are subject to change without notice.
 3. Although great care has been taken to ensure the accuracy and completeness of the information contained in this user's manual, please notify NF Corporation or an NF Corporation sales representative in case any unclear points, errors, or omissions are found. NF Corporation shall not be held responsible for consequential damages arising from the use of this product.
-

HVA4321 Instruction Manual**NF Corporation**

6-3-20 Tsunashima Higashi, Kohoku-ku, Yokohama 223-8508, Japan

TEL +81-45-545-8111

<http://www.nfcorp.co.jp/>

© Copyright 2005, **NF Corporation**

