



WAVE FACTORY

MULTIFUNCTION SYNTHESIZER

WF1966

INSTRUCTION MANUAL

WF1966
2CH 50MHz
SYNTHESIZER
Instruction Manual

WAVE FACTORY

Foreword

Thank you very much for procuring the WF1966 MULTIFUNCTION SYNTHESIZER. At the outset, please take a few minutes to read the Safety Precautions indicated in this manual in order to use this equipment safely and correctly.

● Warning and Caution notices

The following Warning and Caution notices appear in this manual. These must be observed in order to protect both the user from physical harm and the equipment from damage.



WARNING

Risk of serious and possibly fatal physical injury from electric shock or other cause.



CAUTION

Risk of damage to the equipment.

● Manual composition

Please read Section 1 before using the equipment for the first time. Refer to a separate volume for a description of remote control.

Section 1 Overview

Provides a general description of the equipment and a simple outline of the operating principles.

Section 2 Preparation

Required preparatory work before installing and operating the equipment. Be sure to read this section.

Section 3 Basic operation

Panel functions, operating principles and basic operations are described. Read while operating the equipment.

Section 4 Applications

Expanded operations are described.

Section 5 Other operations

Operations not covered in Sections 3 and 4 are described.

Section 6 Troubleshooting

Corrective measures when error messages or abnormalities occur.

Section 7 Maintenance

Inspection and performance tests are described.

Section 8 Specifications

Equipment specifications (functions and performance) are described.

Safety Precautions

Observe the following warnings and cautions in order to use this equipment safely. No responsibility or warranty is assumed for damages arising from use in a manner contrary to these warnings and cautions.

This product is an insulation standard class I device (with a protective conductor terminal) as defined by the IEC standards.

● **Observe text instructions**

This manual has been compiled in order to enable safe operation and use of this equipment. Be sure to read this manual before using the equipment.

Items designated by Warning advise of serious physical hazards. Be sure to observe these carefully.

● **Be sure to connect ground**

Since the unit includes a built-in line filter, there is risk of shock if used without grounding.

To prevent electric shock, be sure to properly connect the device to the electric ground which ground resistance is less than 100 Ω .

● **Confirm power source voltage**

Before connecting this equipment, check that the proper voltage is being supplied to the power outlet.

Refer to the Grounding and Power Supply section of this manual.

● **Use only the properly rated fuse**

Improperly rated fuses present a fire hazard and other risks. Refer to the Grounding and Power Supply section of this manual and confirm the fuse rating.

Be sure to disconnect the equipment from the power source before replacing the fuse.

● **Smoke, odor, noise**

In event smoke, peculiar odor or noise is emitted, immediately disconnect the power source and avoid further operation. Contact service.

● **Flammable gas**

Do not use this equipment in the presence of flammable gas. There is danger of fire and explosion.

● **Do not remove covers**

This equipment contains dangerously high voltages. Do not remove external covers.

Refer all internal inspection and service to a qualified service technician who fully understands the hazards.

● Do not modify

Do not use parts other than specified by the manufacturer and by no means attempt to modify the equipment. There is risk of personnel hazard and damage to the equipment. The manufacturer reserves the option of refusing service in such cases.

● Safety related symbols

Following are general definitions of the symbols and indications used in the text and on the product.



Advises of possible hazard to the user, as well as the need to consult this manual when using an operation or function.



Appears in the text and on the product to advise risk of fatal or otherwise serious physical injury.



Appears in the text and on the product to advise risk of damage to the product.



Ground indication:

Indicates connector housing and signal ground is connected to a chassis ground.



Indicates power switch on state.



Indicates power switch off state.

Contents

● Foreword	i
● Safety Precautions	ii
● Section 1 Overview	1-1
1.1 Features	1-2
1.2 Operating principles	1-3
■ Block diagram	1-3
1.3 Function outline	1-4
■ Main functions	1-4
■ Function tree	1-6
● Section 2 Preparation	2-1
2.1 Check before using	2-2
■ Safety check	2-2
■ Unpacking and repacking	2-2
■ Options	2-2
2.2 Power source and grounding	2-3
■ Grounding	2-3
■ Line filter	2-3
■ Power source	2-3
■ Power supply fuse	2-5
2.3 Installation	2-6
■ Cautions	2-6
■ Installation conditions	2-6
■ Panel and case cleaning	2-6
2.4 Conformable standards	2-7
2.5 Calibration	2-8
● Section 3 Basic Operation	3-1
3.1 Panel description	3-2
■ Front panel	3-3
■ Rear panel	3-4
3.2 Input and output connectors	3-5
■ Waveform output (FUNCTION OUT)	3-5
■ Sync signal output (SYNC OUT)	3-6
■ Trigger/sweep input (TRIG/SWEEP IN)	3-9

■	Sweep stop/restart input (SWEEP PAUSE IN)	3-10
■	Sweep X-DRIVE output (SWEEP X-DRIVE OUT)	3-10
■	Sweep marker output (SWEEP Z-MARKER OUT)	3-11
■	External add input (EXT ADD IN)	3-11
■	External AM input (EXT AM IN)	3-12
■	Synchronized operation input/output (ϕ -SYNC IN/OUT)	3-12
3.3	Basic operation	3-14
■	Setting initialize (PRESET)	3-14
■	Channel mode selection (CHANNEL MODE)	3-17
■	Channel modes and settings	3-19
■	Channel selection	3-21
■	Oscillation mode selection	3-22
■	Waveform selection	3-23
■	Frequency setting	3-24
■	Amplitude setting	3-25
■	DC offset setting	3-26
■	Phase setting	3-27
■	Squarewave rise time/fall time setting (tr/tf)	3-28
■	Output on/off	3-29
■	Operation tree	3-30
●	Section 4 Applications	4-1
4.1	Burst oscillation	4-2
■	Burst oscillation (Type: Burst)	4-2
■	Burst oscillation (Type: Trigger)	4-5
■	Burst oscillation (Type: Gate)	4-9
■	Burst oscillation (Type: Triggered gate)	4-13
4.2	Sweep	4-16
■	Sweep (Mode: Single)	4-16
■	Sweep (Mode: Continuous)	4-22
■	Sweep (Mode: Gated)	4-27
■	CENTER, SPAN, MARKER, MKR → CTR	4-34
■	Summary of the sweep setting items	4-35
■	Sweep (Modulation) steps and step width	4-36
■	Sweep value and marker/sync/X-DRIVE output	4-39
4.3	Modulation	4-41
■	Frequency modulation (FM)	4-41
■	Amplitude modulation (AM)	4-44
■	DC offset modulation (OFSM)	4-47

■ Phase modulation (PM)	4-50
■ Pulse width modulation (PWM)	4-53
4.4 Arbitrary Waveform	4-56
■ Arbitrary waveform (ARB)	4-56
4.5 Switching waveforms of synchronous signals (SYNC OUT)	4-61
■ Procedure	4-61
■ When the oscillation mode is BURST	4-61
■ When the oscillation mode is SWEEP	4-62
■ When the oscillation mode is MODU	4-62
■ Additional information	4-63
4.6 Output waveforms for sweeping and modulation	4-64
4.7 Equivalent noise bandwidth	4-66
● Section 5 Other Operations	5-1
5.1 Convenient Settings	5-2
■ Frequency [Hz] setting by period [s]	5-2
■ Squarewave duty setting	5-3
■ Squarewave pulse width setting	5-6
■ Amplitude and DC offset setting by high and low level	5-7
5.2 Units	5-9
■ Engineering unit (μ , m, k, M) display	5-9
■ Amplitude units change	5-10
■ User-unit setting	5-11
5.3 Setting memory	5-15
■ Setting store	5-15
■ Setting recall	5-16
■ Setting memory clear	5-17
5.4 External input	5-18
■ External add (EXT-ADD)	5-18
■ External AM (EXT-AM)	5-19
5.5 Other settings	5-20
■ Output range change (use with fixed range)	5-20
■ Output on/off at power on	5-21
■ LOAD function (equalize setting and output values)	5-22
■ UNDO function	5-23
■ Pulse generator function	5-24
■ Phase sync	5-26
■ Copy settings between channels	5-27
■ Fixed frequency difference (2TONE)	5-28

■ Fixed frequency ratio (RATIO)	5-29
● Section 6 Troubleshooting	6-1
6.1 Error message	6-2
■ Power on error	6-2
■ Operation error	6-3
6.2 Suspected failure	6-6
■ In case of abnormality	6-6
● Section 7 Maintenance	7-1
7.1 Outline	7-2
■ Work contents	7-2
■ Required test instruments	7-2
7.2 Operation checks	7-3
■ Preparatory checks	7-3
■ Function checks	7-3
7.3 Performance tests	7-5
■ Performance tests	7-5
■ Preparatory checks	7-5
■ Test preparation	7-5
■ Frequency accuracy	7-5
■ Amplitude accuracy	7-6
■ DC offset accuracy	7-6
■ Amplitude vs. frequency characteristics	7-7
■ Sinewave distortion	7-7
■ Squarewave response	7-8
■ Duty factor	7-8
■ Time difference between channels	7-9
● Section 8 Specifications	8-1
8.1 Waveform and output characteristics	8-2
8.2 Output voltage	8-4
8.3 Other functions	8-5
8.4 Initialized settings	8-11
8.5 Remote control	8-12
8.6 Options	8-13
8.7 General items	8-14
■ External drawing	8-15
● Index	Index

Section 1 Overview

1.1 Features	1-2
1.2 Operating principles.....	1-3
■ Block diagram.....	1-3
1.3 Function outline.....	1-4
■ Main functions	1-4
■ Function tree	1-6

1.1 Features

The WF1966 Wave Factory is a multifunctional synthesizer based on the direct digital synthesizer (DDS) system.

Although the WF1966 is 2-channel, the series also includes the single-channel WF1965.

- Frequency setting range : 0.01 μ Hz to 50 MHz
- Maximum output voltage : 20 Vp-p/open, \pm 10 V/open
- Waveform resolution: 14 bits
- Key navigation lights the next keys to be operated, thus improving operational ease.
- User units function allows setting formula and character string to convert settings and display to the desired units.
- LOAD function aligns the setting and actual output voltages when an arbitrary load impedance is connected.
- Convenient use as a pulse generator with pulse period, width, high level and low level setting and display. A trigger delay function is also included.
- Five standard waveforms: sine wave, triangular wave, square wave, rising sawtooth and descending sawtooth, plus arbitrary waveform.
- Variable rise time/fall time of square waves
- Frequency change and frequency sweep are coupled with phase, avoiding waveform cutoff.
- Unpredicted voltage is not produced during amplitude change. Since the output range is fixed, the amplitude can be changed from 0 to maximum without waveform cutoff.
- Versatile channel mode utilizing 2 channels
 - 2 channel independent mode
 - 2 phase mode oscillating at the same frequency
 - 2 tone mode oscillating at a fixed frequency difference
 - Ratio mode oscillating continuously at a fixed frequency ratio
 - Differential mode for simultaneous output of waveforms with top and bottom symmetrical
- Versatile oscillation modes
 - Continuous
 - Intermittent: Burst, trigger, gate, in addition to triggered gate for repeated oscillation start/stop
 - Sweep: Sweep for not only frequency, but also phase, amplitude, DC offset and duty.
 - Modulation: FM (FSK), phase (PSK), AM, DC offset and PWM
 - White noise generator
 - DC voltage generator
- Floating of the analog circuit to reduce effects resulting from a ground loop and to provide isolation between channels
- The 1991 synchronized operation option enables synchronized operation of multiple units, increasing the number of channels enabling the use of the units as oscillator.

1.2 Operating principles

■ Block diagram

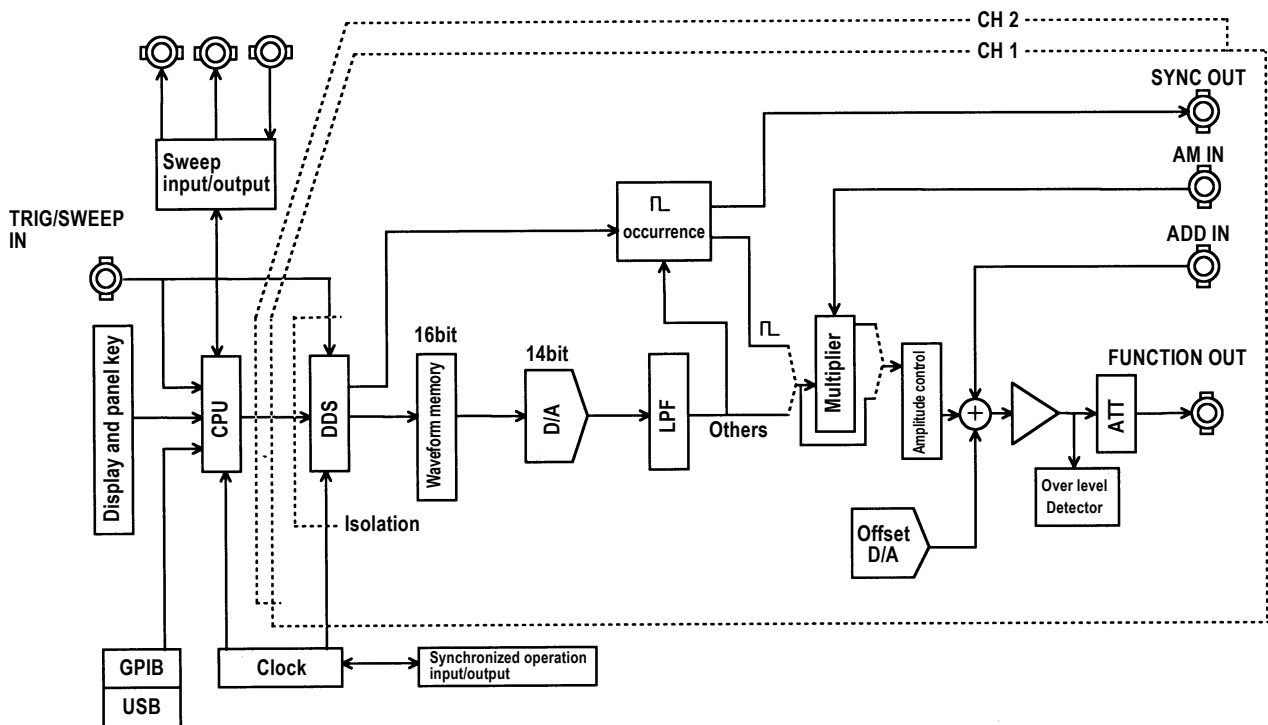

- The CPU conducts analog control for display, panel keys, remote control (GPIB, USB), DDS, amplitude and DC offset. Sweep/internal modulation and sweep input/output control are also conducted.
- The clock generator produces DDS reference and CPU clock signals.
- Two sets of circuits for DDS and analog compose two channels.
- An isolation circuit is inserted between the CPU and DDS, causing the analog circuit to float.
- The DDS (Direct Digital Synthesizer) uses an original LSI device and generates digital data of the setting frequency.
- The waveform memory converts digital data from the DDS into standard or arbitrary waveform data. Waveform data are set from the CPU.
- The digital to analog (D/A) converter produces an analog signal from the resulting waveform data.
- The lowpass filter (LPF) smoothes the stepped D/A output signal.
- Amplitude control is set by the gain control. DC offset is produced by the offset D/A converter and the output amplifier adds and amplifies the output signal.
- The attenuator (ATT) selects the output range by 1/10 attenuation on/off.

1.3 Function outline

■ Main functions

● Channel mode selection

Channel 1 and Channel 2 operation can be set for 2 channel independent(INDEP), 2 phase(2 PHASE), fixed frequency difference (2 TONE), fixed frequency ratio(RATIO) or differential output(DIFF).

● Oscillation mode selection

The oscillation type can be set for continuous(NORMAL), intermittent(BURST), sweep(SWEEP), modulated(MODU), noise(NOISE) or DC(DC).

● Waveform selection

The waveform type can be set for sinewave (\sim), triangle waveform (\wedge), squarewave (\square , 50 % fixed duty), squarewave (\square , variable duty), rising sawtooth (\nearrow), descending sawtooth (\searrow), or arbitrary (ARB).

● Frequency setting

The frequency can be set by the keypad or modify dial.

The period, i.e., inverse of frequency, can also be set.

The duty and pulse width can also be set for the variable duty squarewave.

● Amplitude setting

The amplitude can be set by the keypad or modify dial.

● DC offset setting

The DC offset can be set by the keypad or modify dial.

● Phase setting

Phase between channels and oscillation starting phase during burst oscillation can be set.

● Output on/off

The waveform and sync signal output connectors are on/off switchable for each channel.

The setting prior to power off is returned at power on. Be sure to set to either on or off as required.

- **User units setting**

Coefficients and compensation can be applied to frequency, period, amplitude, DC offset, phase and duty for setting and displaying these in desired units. The units can be expressed by up to 4 desired characters.

- **Setting store and recall**

The settings for frequency, amplitude, etc., can be stored and recalled.

The WF1966 is capable of 10 combinations store/recall.

- **Computer control**

GPIB or USB enables remote control from a personal computer.

■ **Function tree**

Output

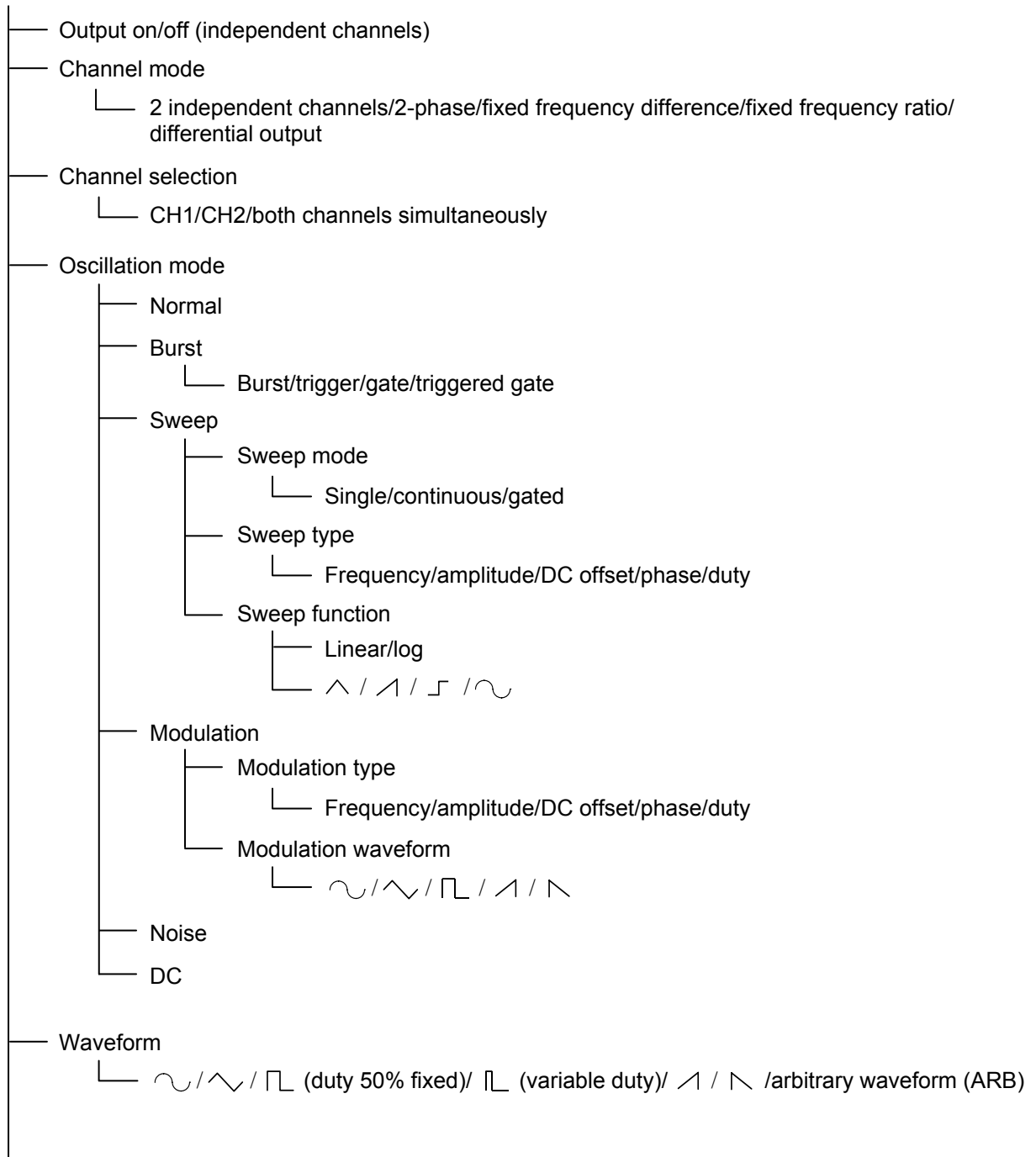

(Continued on the following page)

Output (continued from the preceding page)

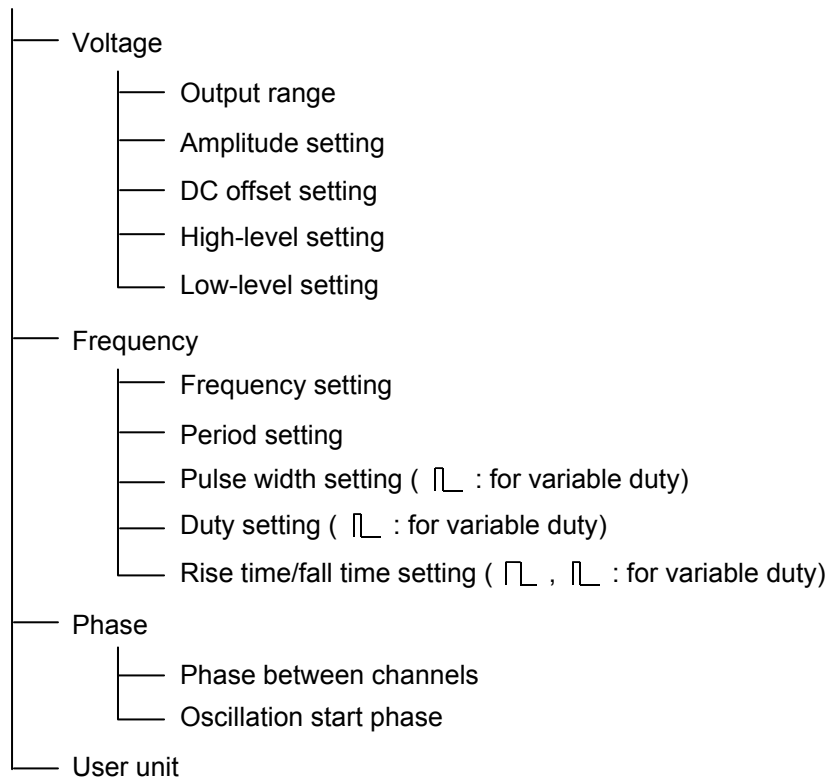

Setting content

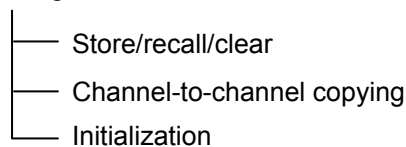

Communication

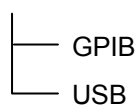

Others

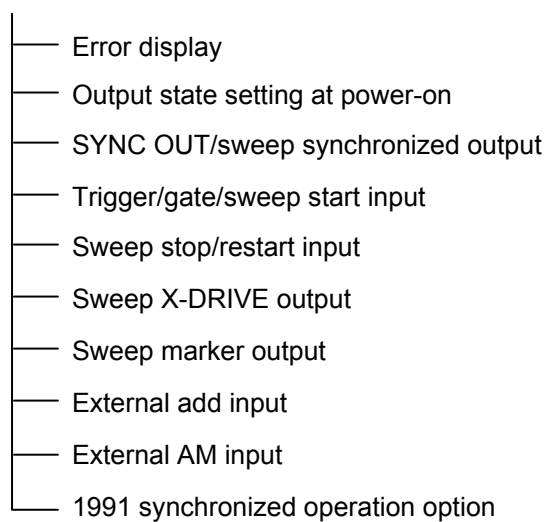

Section 2 Preparation

2.1	Check before using	2-2
■	Safety check	2-2
■	Unpacking and repacking	2-2
■	Options	2-2
2.2	Power source and grounding	2-3
■	Grounding	2-3
■	Line filter	2-3
■	Power source	2-3
■	Power supply fuse	2-5
2.3	Installation	2-6
■	Cautions	2-6
■	Installation conditions	2-6
■	Panel and case cleaning	2-6
2.4	Conformable standards	2-7
2.5	Calibration	2-8

2.1 Check before using

■ Safety check

Before using the WF1966, refer to the **Safety precautions** of this manual and confirm safety.

Also, before connecting the power, refer to **Section 2.2 Power source and grounding** and thoroughly check the safety.

■ Unpacking and repacking

First, inspect the equipment for possible damage in shipping.

Check for the presence of the following items.

Mainframe	1
Instruction Manual	1
Remote Control Instruction Manual	1
0105 Arbitrary Waveform Editor (CD-ROM)	1
Supplied accessories	
Power cable: (3-conductors)	1
Fuse : (100/115 V: 2 A or 230 V: 1 A)	1
(Time lag, 250 V, $\phi 5.2 \times 20$ mm)	

For information on how to use 0105 Arbitrary Waveform Editor, refer to the CD-ROM of the 0105.

When repacking the equipment for transportation, use a packing carton having ample strength to protect the equipment and bear the weight of stacking.



WARNING

Do not remove covers.

This equipment contains dangerously high voltages. Do not remove external covers.

Refer all internal inspection and service to a qualified service technician who fully understands the hazards.

■ Options

- 1991 synchronous operation option

If ordered, this option is installed at time of shipment.

- 1994 synchronous operation cable

Cable (1 meter) used with the 1991 synchronous operation option.

The required number of cables is one less than the total number of connected units.

2.2 Power source and grounding

■ Grounding



The WF1966 uses a line filter that incorporates the circuit below.

This equipment must be grounded in order to prevent electric shock accidents.

Confirm the protective ground terminal is connected to ground before connecting the equipment for measurements. The WF1966 protective ground is connected to ground by the 3-prong power supply plug.

Use the supplied power supply cable to connect to a 3-terminal power outlet that has a protective ground contact.

■ Line filter

The WF1966 uses a line filter that incorporates the circuit below.

Because the maximum leakage current is 0.5 mArms at 250 V/62 Hz, touching a metallic part of the WF1966 could cause an electric shock.

For your safety, be sure to ground the device.

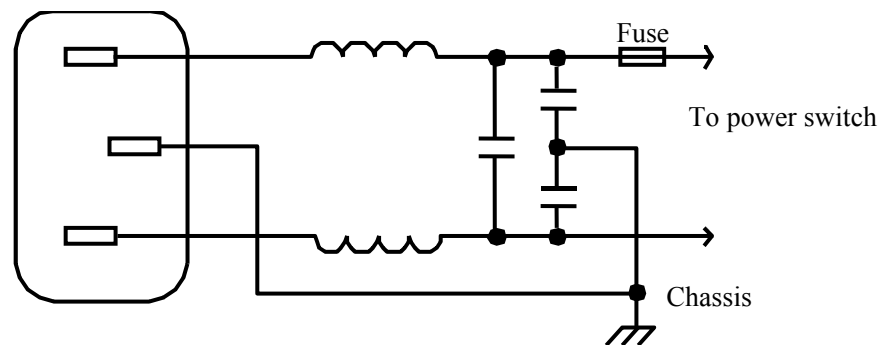

■ Power source



Be sure to observe the following in order to prevent damage to the equipment.

Confirm the power source voltage is within the range specified for the WF1966.

Check the power source voltage indication on the rear panel above the power source inlet. The WF1966 operates from the following commercial power source.

Power supply voltage range:	AC100V/115V/230V±10%
Power supply frequency range:	50/60 Hz ±2 Hz
Power consumption:	Max. 100 VA
Overvoltage category:	II

Connect to the power source according to the following procedure:

1. Set the WF1966 power switch to off.
2. Adjust the source voltage change-over switch at the back of the unit to the source voltage to be used.
3. Insert the power cable into the power inlet on the back of the unit.
4. Insert the power cable plug into a 3-terminal wall socket.

With a screwdriver, move the slide control of the source voltage change-over switch to the line indicating the source voltage to be used. Do not set the slide control between lines.

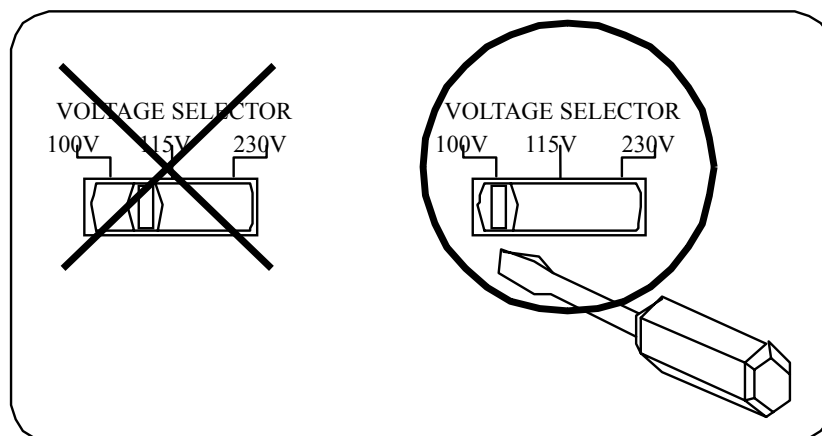

Before using the WF1966 with a source voltage that differs from the factory setting, be sure to contact the sales representative of NF Corporation.

Make sure that the power switch is off before connecting the power cable. Also, after switching power off, wait at least five seconds before switching the power on again.

Confirm the power switch is off before connecting the power cable.

Also, after switching power off, wait at least 5 seconds before again switching power on.

■ Power supply fuse



WARNING

Use only a fuse with the specified rating.

There is risk of fire from an improperly rated fuse. Be sure to disconnect the power cable before replacing the fuse.

Fuse: Time lag 2 A (100/115 V) or time lag 1 A (230 V)
250 V, $\phi 5.2 \times 20$ mm

The specified rating of a fuse changes depending on the power source voltage.

2.3 Installation

■ Cautions



Observe the following cautions to avoid damaging the WF1966.

- The unit is cooled by a fan. In event the fan does not function, switch off the power and contact service. Continued use without the fan operating can lead to extensive damage and service complexity.
- Ventilation openings are located on the side and rear panels. Avoid obstructing the openings and provide at least 10 cm clear space at the sides and back of the unit when installing.
- Do not use the unit vertically (with the rear panel downward).

■ Installation conditions

Observe the following ambient when installing and storing the equipment. Moisture condensation must also be absent.

Temperature and humidity ranges

Guaranteed performance: +5 to +35 °C, 5 to 85 %RH
(no condensation at an absolute humidity of 1 to 25 g/m³)

Ambient storage conditions: -10 to +50 °C, 5 to 95 %RH
(no condensation at an absolute humidity of 1 to 29 g/m³)

Avoid installing the equipment in the following types of locations.

- In direct sunlight or near heat sources
- Where subjected to dust, salt or metallic dust
- Corrosive gas, steam or oily smoke
- Flammable gas or vapors
- Strong vibration
- Strong magnetic or electromagnetic fields
- Near pulse type noise sources

Also, when using, provide separation between the power cords and signal cables of the WF1966 and those of other equipment. Operating error can occur if the power cords and signal cables are too close. Cable routing requires particular attention when installing in a rack or other facility.

■ Panel and case cleaning

Use a soft cloth to wipe dust from the panel and case. If soiling is severe, moisten the cloth slightly with a neutral detergent.

Do not use sprays, petroleum distillates or commercial cleaning cloths, which can deform or peel the finish.

2.4 Conformable standards

The WF1966 conforms to the following standards.

Safety: EN 61010-1: 2001

EMC: EN 61326: 1997/A1: 1998/A2: 2001

However, the performance criteria for the following standards are as follows:

EN61000-4-2(1995):C

EN61000-4-4(1995), EN61000-4-5(1995), EN61000-4-11(1994):B

The phase synchronization (ϕ SYNC) operation may be required because the phase difference between channels is caused by the electrostatic discharge.

The following cables are used for the test of EN 61326: 1997/A1: 1998/A2: 2001

- Power cable : Accessory
- Signal cables : Coaxial cable with BNC connectors, 1 m (3D-2W or RG-143B/U or RG-223/U)
- GPIB cable : Shielded cable, 1 m (DDK: 408JE-101)

2.5 Calibration

Section 7.3 the **Performance tests** are recommended at least once a year. These should also be conducted before important tests and measurements.

Section 3 Basic operation

3.1	Panel description	3-2
	■ Front panel	3-3
	■ Rear panel	3-4
3.2	Input and output connectors	3-5
	■ Waveform output (FUNCTION OUT)	3-5
	■ Sync signal output (SYNC OUT)	3-5
	■ Trigger/sweep input (TRIG/SWEEP IN)	3-5
	■ Sweep stop/restart input (SWEEP PAUSE IN)	3-5
	■ Sweep X-DRIVE output (SWEEP X-DRIVE OUT)	3-5
	■ Sweep marker output (SWEEP Z-MARKER OUT)	3-5
	■ External add input (EXT ADD IN)	3-5
	■ External AM input (EXT AM IN)	3-5
	■ Synchronous operation input and output (ϕ -SYNC IN, OUT)	3-5
3.3	Basic operation	3-5
	■ Setting initialize (PRESET)	3-5
	■ Channel mode selection (CHANNEL MODE)	3-5
	■ Channel modes and settings	3-5
	■ Channel selection	3-5
	■ Oscillation mode selection	3-5
	■ Waveform selection	3-5
	■ Frequency setting	3-5
	■ Amplitude setting	3-5
	■ DC offset setting	3-5
	■ Phase setting	3-5
	■ Squarewave rise time/fall time setting (tr/tf)	3-5
	■ Output on/off	3-5
	■ Operation tree	3-5

• Following is an example of the display when using this section.

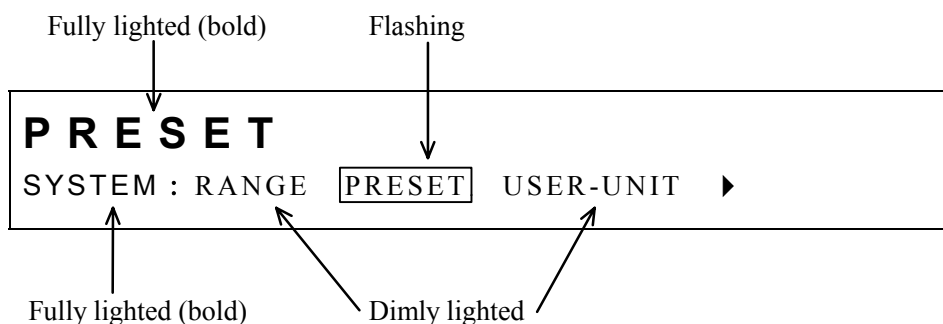

3.1 Panel description

This section describes the indications and functions of the front and rear panels of the WF1966.

■ Rear panel

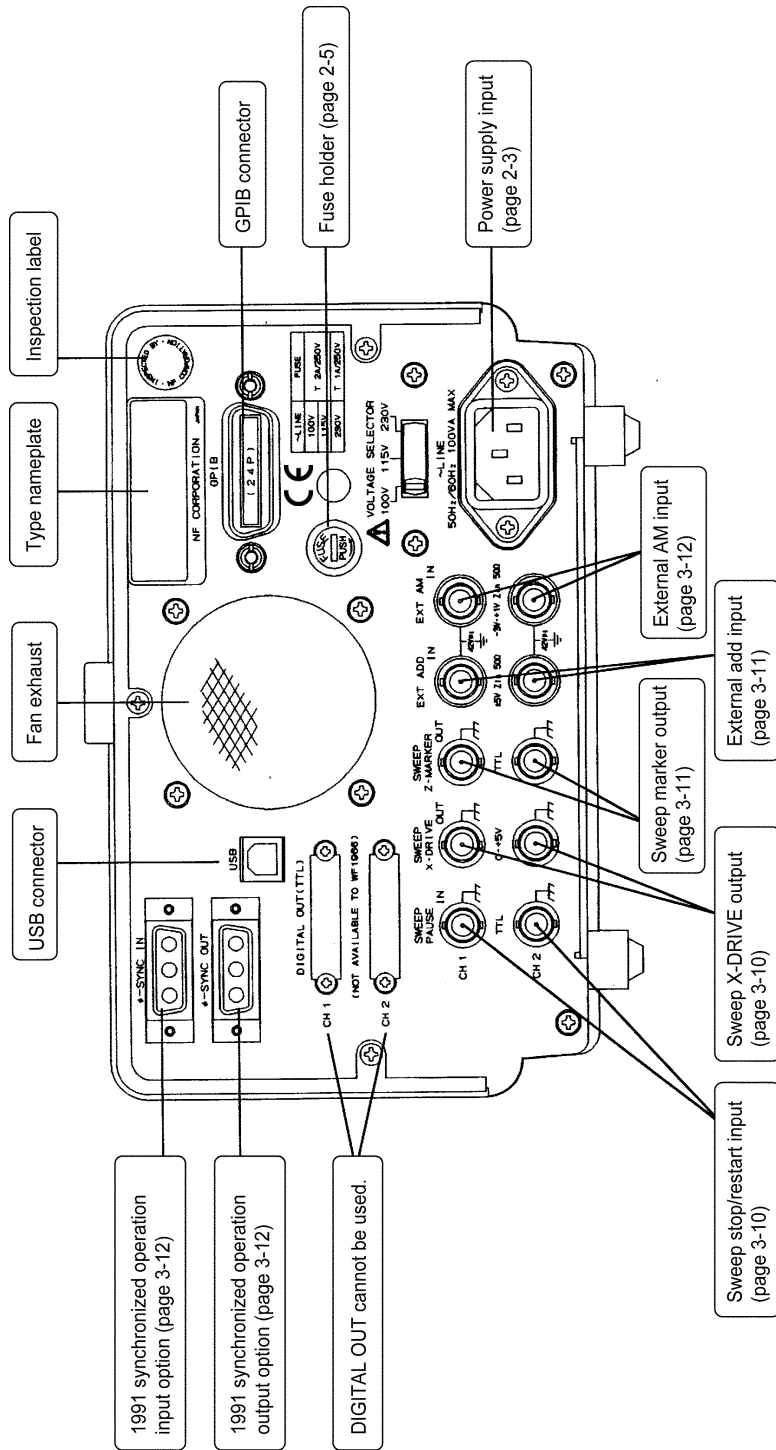

3.2 Input and output connectors

■ Waveform output (FUNCTION OUT)

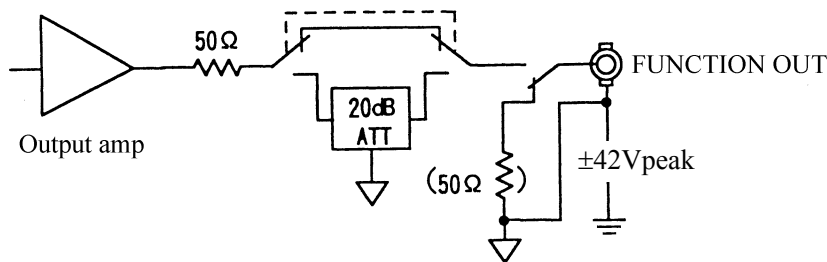

Maximum output voltage :	20 Vp-p/open, 10 Vp-p/50 Ω load
Output impedance :	50 Ω, unbalanced
Load impedance:	More than 45 Ω
Output off status :	Open when output off (can be modified for 50 Ω at output off. Consult company.)
Ground :	Connected to signal ground (floated from the chassis)

⚠ CAUTION

Avoid shorting the output or applying an external signal. The unit can be damaged.

• Output limiting

If the output voltage exceeds the following values, the output may be clipped depending on the high level/low level settings or the relationship between the amplitude and DC offset setting, and the external add and external AM settings.

10 V range:	Approx. 10 Vp/open
10 V range:	Approx. 5 Vp/50 Ω load
1 V range:	Approx. 1.0 Vp/open
1 V range:	Approx. 0.5 Vp/50 Ω load

If the internal circuit is overloaded by the output voltage, the Over lamp lights.

Although the operation is not a failure, the lamp indicates that the operation is not normal.

• Output connection note

Since FUNCTION OUT outputs high-speed signals, the WF1966 is designed for use with 50 Ω termination. To prevent performance deterioration, use a coaxial cable with a characteristic impedance of 50 Ω to connect to other equipment and terminate the input of equipment to be connected with 50 Ω. Although possible, using the equipment without 50 Ω termination could lead to waveforms disturbed by signal reflection or performance deterioration.

• Setting and output voltages

The setting voltage display and actual output voltage (load terminal voltage) differ according to the load resistance. “5.5 Other settings (■LOAD function (equalize setting and output values))”, cf.

■ Sync signal output (SYNC OUT)

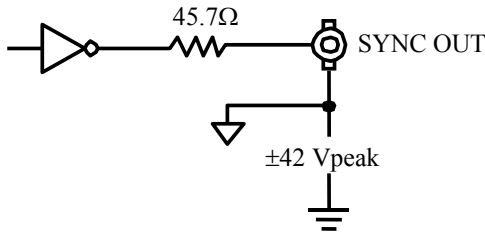

- Output waveform : □
- Output voltage : 0 V/+5 V (open)
- Output impedance: 50 Ω, unbalanced
- Load impedance: More than 45 Ω
- Status at output off : High impedance
- Ground : Connected to signal ground (floated from the chassis)

! CAUTION

Avoid shorting the output or applying an external signal. The unit can be damaged.

• Output connection note

The SYNC OUT impedance is 50 Ω. By using coaxial cable with 50 Ω characteristic impedance for connection to other equipment, waveform disturbance can be reduced. Although 50 Ω termination is possible, the high level voltage is reduced by about half.

• Waveform and sync signal output relationship (Waveform phase definition)

(1) Continuous oscillation mode (NORMAL)

① Sinewave

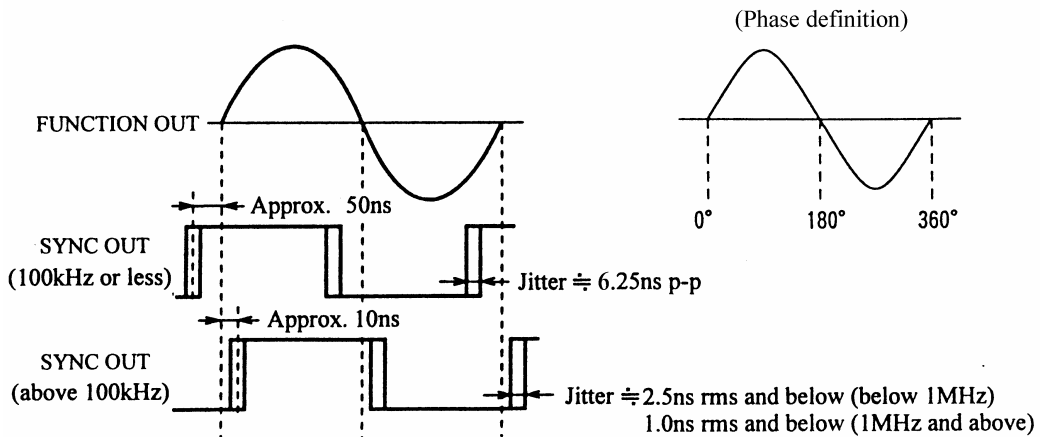

② Triangular, rising sawtooth, descending sawtooth, arbitrary

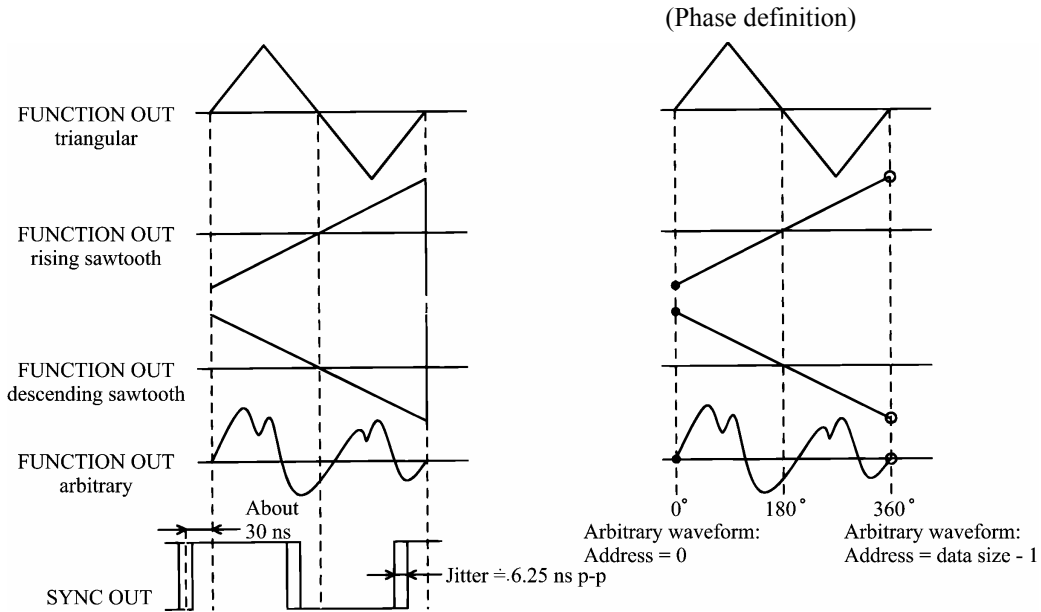

③ Squarewave (fixed 50 % duty)

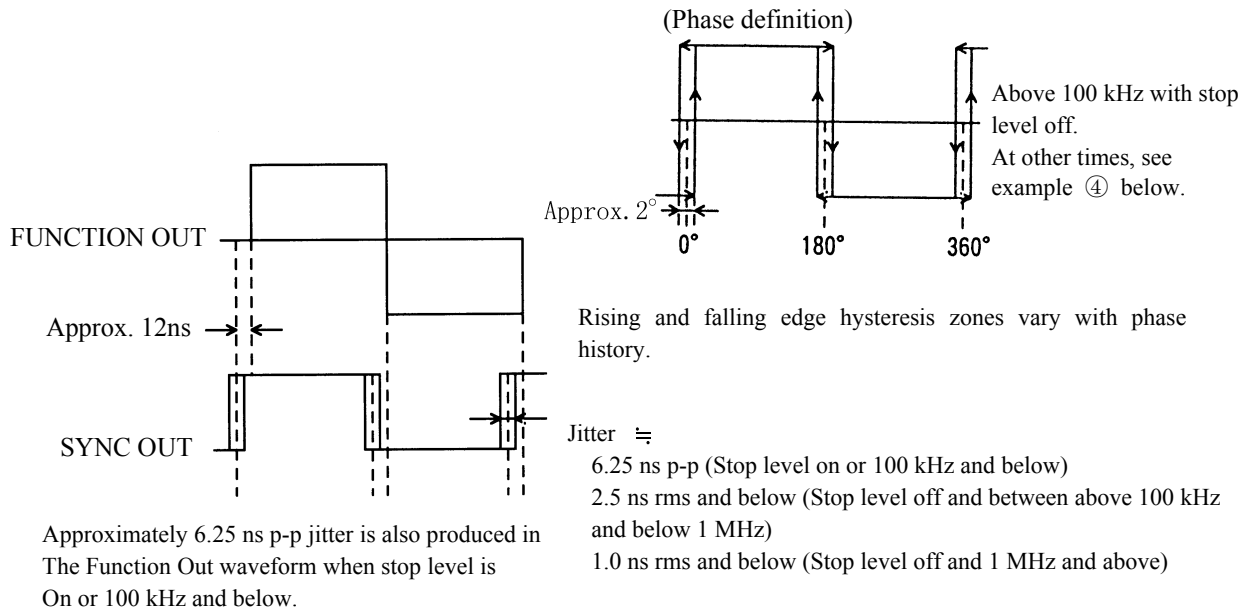

④ Squarewave (variable duty)

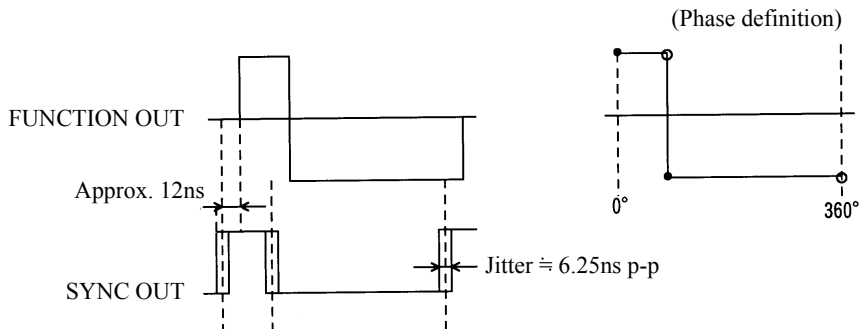

Approximately 6.25 ns p-p jitter is also produced in the Function Out waveform.

(2) Burst mode (BURST)

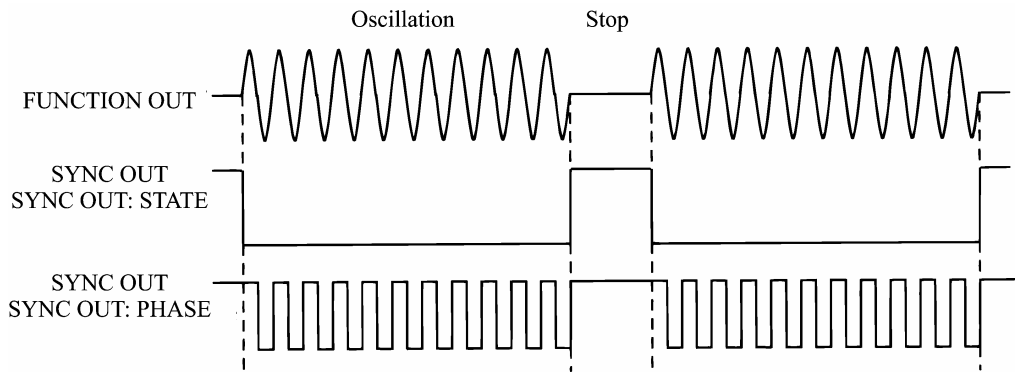

(3) Sweep mode (SWEEP)

Low level during sweep from start to stop points. High level at other times.

☞ “4.2 Sweep (■Sweep value and marker/sync/X-DRIVE/output)”, cf.

(4) Modulation mode (MODU)

High level when modulation waveform phase is above 0 and less than 180 degrees. Low level above 180 and below 360 degrees.

Waveform example during internal AM modulation (when the modulation waveform is \wedge and the modulation factor is 100%)

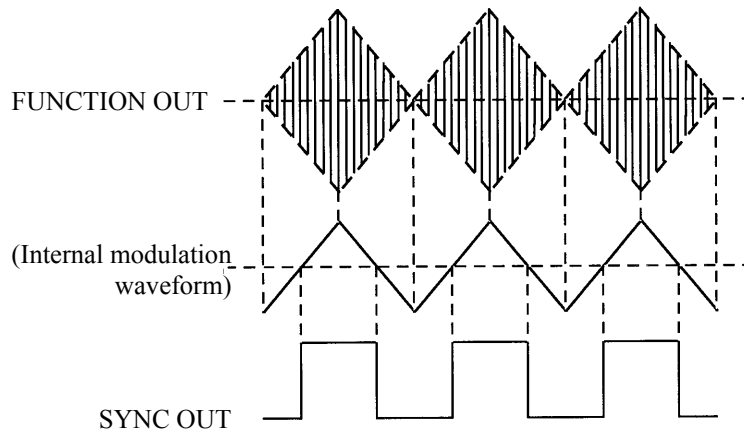

(5) Noise mode (NOISE)

Digital (binary) noise source output.

(6) DC mode (DC)

Always high level.

■ Trigger/sweep input (TRIG/SWEEP IN)

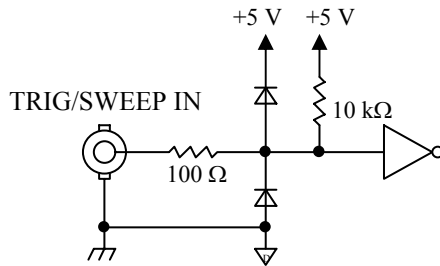

Signal characteristics: The following types are produced during the burst oscillation mode.

Trigger: Select oscillation start for either \uparrow or \downarrow .

Gate: Select oscillation at either high or low level.

Triggered gate: Oscillation start/stop at \uparrow or \downarrow . Select either.

Minimum pulse width is 50 ns.

In sweep oscillation mode, the sweep starts at \uparrow or \downarrow . Select either.

Minimum pulse width is 200 ns.

Input voltage : High level $\geq +3.9$ V
Low level $\leq +1.6$ V

Input voltage range : -0.5 to $+5.5$ V

Input impedance : Pull up to $+5$ V at approx. 10 k Ω

Ground : Connected to chassis ground

CAUTION

Do not apply a signal exceeding the above input voltage range. The unit can be damaged.

• Drive circuit examples

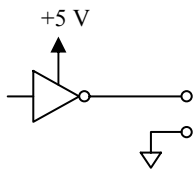

(a) TTL logic output

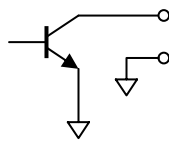

(b) Open collector output

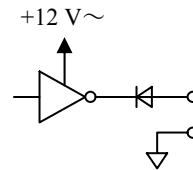

(c) High voltage logic output

Connect the trigger and sweep input drive signals to TTL or C-MOS logic IC outputs.

Since the input circuit is provided with a built-in pullup resistor, an open collector output drive can also be used. However, contact chatter from a mechanical switch or relay can prevent normal operation. Also, chattering will prevent normal operation when the oscillation mode is triggered gate.

Avoid using a logic IC circuit having a power supply voltage higher than $+5$ V such as example (c) for the WF1966 input

■ Sweep stop/restart input (SWEEP PAUSE IN)

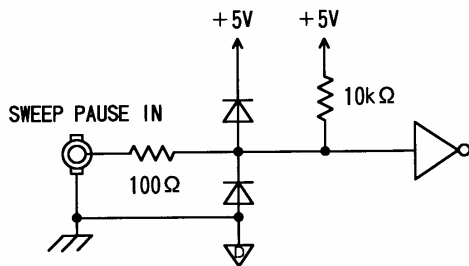

- Signal characteristics : Sweep stop = Low level
Sweep restart = High level
- Input voltage : High level $\geq +3.9$ V
Low level $\leq +1.6$ V
- Input voltage range : -0.5 to +5.5 V
- Input impedance : Pull up to +5 V with about 10 k Ω
- Ground : Connected to chassis ground

CAUTION

Do not apply a signal exceeding the above input voltage range. The unit can be damaged.

- Driver circuit example
- 3.2 Input and output connectors (■ Trigger/sweep input)

■ Sweep X-DRIVE output (SWEEP X-DRIVE OUT)

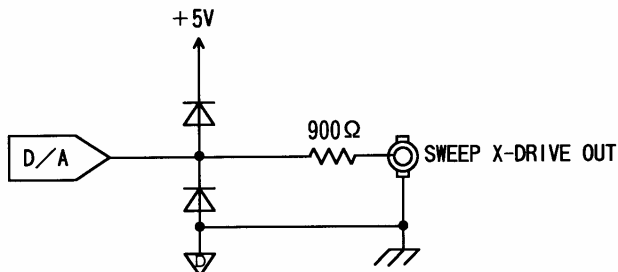

- Signal characteristics : 0 V \rightarrow +5 V = Sweep value is rising
+5 V \rightarrow 0 V = Sweep value is falling
- Output voltage : 0 to +5 V (open)
- Output impedance : About 1 k Ω
- Recommended load : 10 k Ω or more
- Ground : Connected to chassis ground

CAUTION

Avoid shorting the output or applying an external signal. The unit can be damaged.

■ Sweep marker output (SWEEP Z-MARKER OUT)

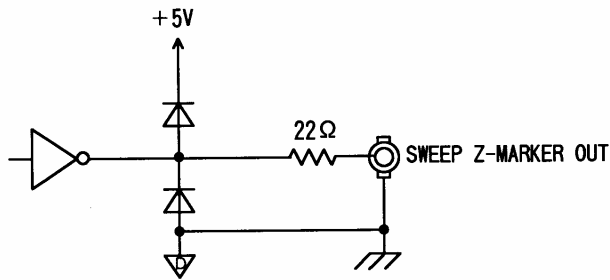

Signal characteristics : Low level = Sweep value is larger than marker value
 High level = All other times

Output voltage : 0 V/+5 V

Recommended load : 1 k Ω or more

Ground : Connected to chassis ground

CAUTION

Avoid shorting the output or applying an external signal. The unit can be damaged.

■ External add input (EXT ADD IN)

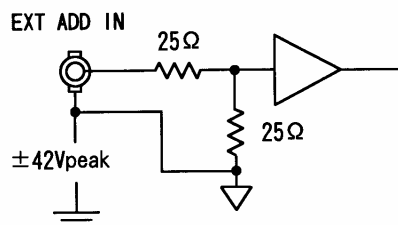

Input voltage : Within ± 5 V

Input impedance : 50 Ω

External add frequency : 10 MHz or less

Ground : Connected to signal ground (floated from the chassis)

CAUTION

Do not apply a signal exceeding the above input voltage. The unit can be damaged.

■ External AM input (EXT AM IN)

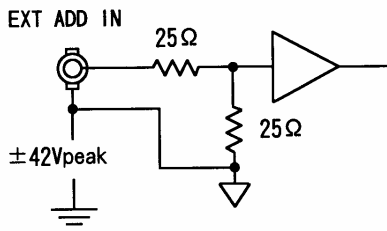

- Input voltage : -3 V to +1 V
(output -100% at -3 V, output 0% at -1 V, and output 100% at +1 V)
- Input impedance : 50 Ω
- Modulated frequency : 10 MHz or less
- Ground : Connected to signal ground (floated from the chassis)



Do not apply a signal exceeding the above input voltage range. The unit can be damaged.

■ Synchronous operation input and output (φ-SYNC IN, OUT)

(Options, 1991 and 1994)

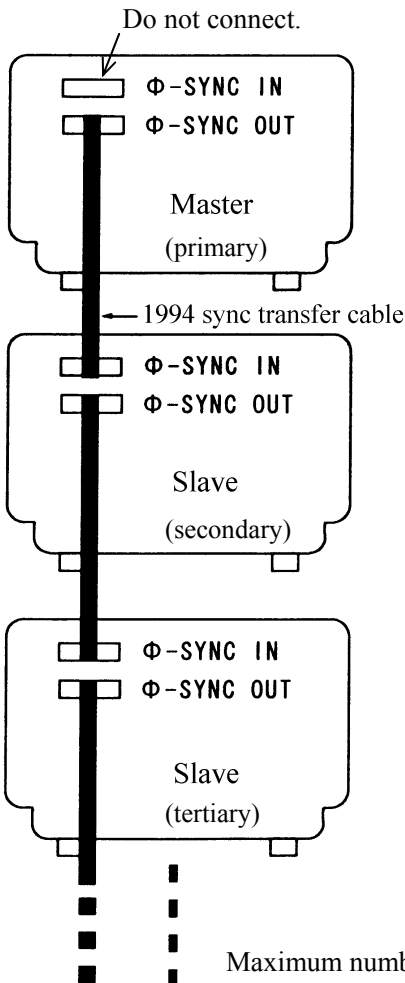

Note: Effective during continuous (Normal) oscillation mode.

Timing error: Maximum 35 ns per unit. Thus, phase error of 0.1 degree at approx. 8 kHz and 1 degree at approx. 80 kHz.

Description: The clock is sent from Master to Slave (secondary) to Slave (tertiary). The delay per unit is approximately 17 nanoseconds. The clock period is approximately 25 ns. The phase synchronizing pulse can be generated by any of the master or slave units and sent toward the terminal. Delay per unit is approximately 8 ns. Due to the phase difference from this delay time, the error between adjacent units is approximately 25 ns (clock period) + 8 ns (phase sync pulse delay) = 33 ns.

The WF1945A, WF1946A, WF1965, WF1966, WF1945 (1945), WF1946 (1946), and WF1956 (1956) equipped with the 1991 can be connected.

**CAUTION**

Note the following for synchronous operation of multiple products:

- **Switch off all products before connecting or disconnecting sync transfer cables.**
- **Switch on all products that are connected by the sync transfer cables and that will be used. Disconnect the sync transfer cable from any product that will not be used.**
- **If possible, simultaneously switch on all products that are connected by the sync transfer cables.**

If simultaneous switch-on is not possible, switch on products in succession from the master (primary) side to the slave (secondary, tertiary) side.

- **If possible, simultaneously switch off all products that are connected by the sync transfer cables.**

If simultaneous switch-off is not possible, switch off products in succession from the slave (secondary, tertiary) side to the master (primary) side.

3.3 Basic operation

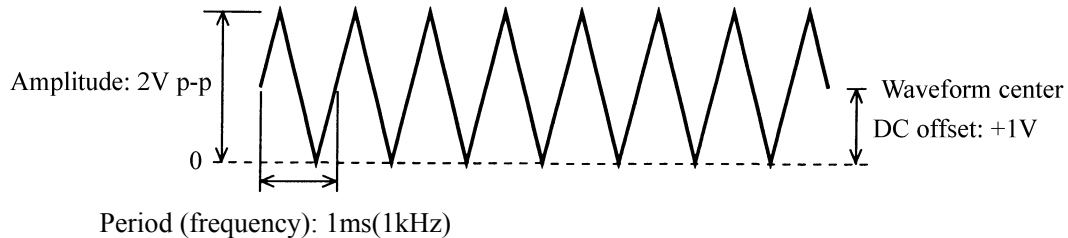

Basic operation is described using an example of a triangular waveform with frequency 1 kHz, amplitude 2 Vp-p and DC offset +1 V from the waveform output connector.







■ Setting initialize (PRESET)

The operation of initializing all settings is described. This instruction manual presumes operation directly after initializing.

Operation:

- ① Press the  key, then use the  and  keys to produce the following display. (lower PRESET flashes).

```
PRESET
SYSTEM : RANGE PRESET USER-UNIT ▶
```

- ② Press the  key (upper PRESET flashes).
- ③ Again press the  key to initialize. To return without initializing, before pressing , press the  key twice.

Initialized settings :

Initialized settings are indicated in the table.

Settings related to output on/off, output on/off at power on, arbitrary waveform, setting memory, user units , remote control, GPIB address, GPIB delimiter, and USB ID are not initialized.







Initialization table

Key operation	Menu	Initial settings	Remarks
CH 1/CH 2		CH 1(BOTH is off)	
CHANNEL MODE		INDEP	
MODE		NORMAL	
MODE→BURST	TYPE	BURST	
	SOURCE	EXT $\overline{\downarrow}$ (1 ms, at INT)	When TYPE=TRIG, GATE,T-GATE
	SOURCE(CH2)	EXT CH2 $\overline{\downarrow}$ (1 ms, at INT)	When TYPE=TRIG, GATE,T-GATE
	DELAY	0.3 μ s	When TYPE=TRIG
	MARK	1.0	When TYPE=BURST, TRIG
	SPACE	1.0	When TYPE=BURST
	STOP-LEVEL	OFF (0%, at ON).	
MODE→SWEEP	OPER-COMMON	OFF	Both channels MODE=BURST, TYPE=TRIG, GATE or T-GATE, same TYPE.
	TYPE	FREQ	
	SOURCE	EXT $\overline{\downarrow}$ (1 ms at INT)	When MODE=SINGLE, GATED
	SOURCE(CH2)	EXT CH2 $\overline{\downarrow}$ (1 ms, at INT)	When MODE=SINGLE, GATED
	MODE	SINGLE	
	FUNCTION	LIN \nearrow	
	TIME	1 s	
	STOP-LEVEL	OFF (0%, at ON).	When MODE=GATED
MODE→SWEEP, TYPE=FREQ	OPER-COMMON	OFF	When both channels SWEEP MODE
	START	1000 Hz	
	STOP	10000 Hz	
	CENTER	5500 Hz	
	MARKER	5000 Hz	
MODE→SWEEP, TYPE=AMPTD	SPAN	9000 Hz	
	START	0.1 Vp-p	
	STOP	1 Vp-p	
	CENTER	0.55 Vp-p	
	MARKER	0.5 Vp-p	
MODE→SWEEP, TYPE=OFFSET	SPAN	0.9 Vp-p	
	START	0.1 V	
	STOP	-0.1 V	
	CENTER	0 V	
	MARKER	0 V	

Continued next page

3.3 Basic operation

Continued from previous page

Key operation	Menu	Initial settings	Remarks
MODE→SWEEP, TYPE=PHASE	START	-90 deg	
	STOP	90 deg	
	CENTER	0 deg	
	SPAN	180 deg	
	MARKER	0 deg	
MODE→SWEEP, TYPE=DUTY	START	40 %	
	STOP	60 %	
	CENTER	50 %	
	SPAN	20 %	
	MARKER	50 %	
MODE→MODU	TYPE	FM	
	FREQUENCY	100 Hz	
	FUNCTION		
	OPER-COMMON	OFF	When both channels MODU MODE
MODE→MODU, TYPE=FM	DEVIATION	1000 Hz	
MODE→MODU, TYPE=AM	DEPTH	50 %	
MODE→MODU, TYPE=OFSM	DEVIATION	0.2 V	
MODE→MODU, TYPE=PM	DEVIATION	90 deg	
MODE→MODU, TYPE=PWN	DEVIATION	20 %	
ENTRY→FREQ		1000 Hz	
ENTRY→AMPTD		0.1 Vp-p	
ENTRY→OFFSET		0 V	
ENTRY→PHASE		0 deg	
ENTRY→WIDTH		0.0005 s	In case of FUNCTION= 
ENTRY→DUTY		50 %	In case of FUNCTION= 
ENTRY→PERIOD		0.001 s	
ENTRY→HIGH		0.05 V	
ENTRY→LOW		-0.05 V	
ENTRY→Δ FREQ		0 Hz	When CHANNEL MODE=2 TONE
ENTRY→RATIO		0000001:0000001	When CHANNEL MODE=RATIO
ENTRY→tr/tf		7ns	When FUNCTION=  , 
FUNCTION			
SYSTEM	RANGE	AUTO	
	LOAD	OPEN (50 ohms at SET)	
	EXT-AM	OFF	
	EXT-ADD	OFF	
	DUTY-VALID	IMMED	
	SYNC OUT	STATE	

■ Channel mode selection (CHANNEL MODE)

The channel mode and CH1/CH2 operation are described.

Definitions:

INDEP (independent 2 channel) : CH1 and CH2 operate independently.

2 PHASE : CH1 and CH2 operate at the same frequency.

Example:

CH1	1 kHz	→	10 kHz
CH2	1 kHz		10 kHz

Frequency sweep and frequency modulation settings and operation are also the same for CH1 and CH2.

2 TONE (fixed frequency difference) : CH1 and CH2 operate continuously at a fixed frequency difference.

Example:

CH1	1 kHz	→	10 kHz
CH2	2 kHz		11 kHz

Frequency sweep and frequency modulation settings are at the fixed frequency difference.

 "5.5 Other settings (■ Fixed frequency difference (2TONE))", cf.

RATIO (fixed frequency ratio) : CH1 and CH2 operate continuously at a fixed frequency ratio.

Example:

CH1	1 kHz	→	10 kHz
CH2	2 kHz		20 kHz

Frequency sweep and frequency modulation settings are at the fixed frequency ratio.



 "5.5 Other settings (■ Fixed frequency ratio (RATIO))", cf.

DIFF (differential output) : CH1 and CH2 operate at the same frequency, amplitude and DC offset, but at opposite waveforms (reverse phase).



In this mode, amplitude, DC offset, output range, output on/off, phase, frequency sweep and frequency modulation settings are copied from CH1 to CH2.

Operation:

As an example, 2 phase operation is described.

- ① Press the  key, then select the mode with the  and  keys (2 PHASE flashes in this example).



- ② Press the  key to change the mode.
The  lamp above the  key lights.
This completes channel mode change.

Other:

- When the channel mode is changed, the CH2 setting is determined on the basis of the CH1 setting.
- The channel mode and setting relationships
 “3.3 Basic operation (■Channel modes and settings)”, cf.

■ Channel modes and settings

Operation and setting limits for each channel mode are given in the following table.

- : Each channel is set independently.
- △ : Both channels have the same settings.
- × : Not settable
- ▲ : Frequency difference (Δ FREQ) and frequency ratio (RATIO) relationships are maintained.

*1: Gated sweep mode not selectable

*2: LOG sweep function not selectable

*3: Only CH1 usable for TRIG/SWEEP IN and SWEEP PAUSE IN

*4: When the oscillation mode is sweep or modulation, FREQ indicated the type is frequency and OTHER indicates other than this.

*5: Control operation is common between channels.

Key operation	Channel mode→	[INDEP]	[2PHASE]		[2TONE]		[RATIO]		[DIFF]	Note
	Menu name		FREQ *5	other *5	FREQ *5	other *5	FREQ *5	other *5		
MODE→NORMAL		○	△	○	△	○	△	○	△	
MODE→BURST		○	×	×	×	×	×	×	×	
	TYPE	○	×	×	×	×	×	×	×	
	SOURCE	○	×	×	×	×	×	×	×	SOURCE other than TYPE=BURST
	INT/EXT	○	×	×	×	×	×	×	×	
	INT RATE	△	×	×	×	×	×	×	×	RATE is internal trigger period
	INT ↑↓	○	×	×	×	×	×	×	×	
	EXT ↑↓	○	×	×	×	×	×	×	×	
	EXT CH	○	×	×	×	×	×	×	×	
	DELAY	○	×	×	×	×	×	×	×	When TYPE=TRIG
	MARK	○	×	×	×	×	×	×	×	When TYPE=BURST and TRIG
	SPACE	○	×	×	×	×	×	×	×	When TYPE=BURST
	STOP-LEVEL	○	×	×	×	×	×	×	×	
OPER-COMMON	△	×	×	×	×	×	×	×	Both channels BURST and same TYPE	
MODE→SWEEP		○	△	○	△	○	△	○	△	
	TYPE	○	△	○	△	○	△	○	△	
	SOURCE	○	△	○	△	○	△	○	△	SOURCE other than MODE=CONT
	INT/EXT	○	△	○	△	○	△	○	△	
	INT RATE	△	△	△	△	△	△	△	△	RATE is internal trigger period
	INT ↑↓	○	△	○	△	○	△	○	△	
	EXT ↑↓	○	△	○	△	○	△	○	△	
	EXT CH	○	CH1*4	○	CH1*4	○	CH1*4	○	CH1*4	
	MODE	○	△*2	○*2	△*2	○*2	△*2	○*2	△*2	
	FUNCTION	○	△	○	△*3	○*3	△	○	△	
	START	○	△	○	▲	○	▲	○	△	
	STOP	○	△	○	▲	○	▲	○	△	
	TIME	○	△	○	△	○	△	○	△	
	STOP-LEVEL	○	×	×	○	○	×	×	×	When MODE=GATE
	CENTER	○	△	○	▲	○	▲	○	△	
	SPAN	○	△	○	△	○	▲	○	△	
	MARKER	○	○	○	○	○	○	○	△	
MKR→CTR	○	△	○	△	○	△	○	△		

Continued next page

3.3 Basic operation

Continued from previous page

Key operation	Channel mode→	[INDEP]	[2PHASE]		[2TONE]		[RATIO]		[DIFF]	Note
	Menu name		FREQ *5	other *5	FREQ *5	other *5	FREQ *5	other *5		
MODE→SWEEP	START-STATE	○	△	○	▲	○	▲	○	△	
	STOP-STATE	○	△	○	▲	○	▲	○	△	
	OPER-COMMON	△	ON*6	△	ON*6	△	ON*6	△	ON*6	When both channels SWEEP mode
MODE→MODU		○	△	○	△	○	△	○	△	
	TYPE	○	△	○	△	○	△	○	△	
	DEVIATION	○	△	○	△	○	▲	○	△	
	DEPTH	○	×	○	×	○	×	○	△	
	FREQ	○	△	○	△	○	△	○	△	
	FUNCTION	○	△	○	△	○	△	○	△	
	OPER-COMMON	△	ON*6	△	ON*6	△	ON*6	△	ON*6	When both channels are MODU
MODE→NOISE		○	×	×	×	×	×	×	×	
MODE→DC		○	×	×	×	×	×	×	×	
ENTRY→FREQ		○	△	△	▲	▲	▲	▲	△	
ENTRY→AMP/PTD		○	○	○	○	○	○	○	△	
ENTRY→OFFSET		○	○	○	○	○	○	○	△	
ENTRY→PHASE		○	○	○	○	○	○	○	△	
ENTRY→WIDTH		○	○	○	○	○	○	○	△	
ENTRY→DUTY		○	○	○	○	○	○	○	△	
ENTRY→PERIOD		○	△	△	▲	▲	▲	▲	△	
ENTRY→HIGH		○	○	○	○	○	○	○	△	
ENTRY→LOW		○	○	○	○	○	○	○	△	
ENTRY→tf/tf		○	○	○	○	○	○	○	△	
FUNCTION→?		○	○	○	○	○	○	○	△	? is waveform select
ARB EDIT	SELECT	○	○	○	○	○	○	○	△	
	NAME	○	○	○	○	○	○	○	△	
	EDIT	○	○	○	○	○	○	○	△	
	COPY	○	○	○	○	○	○	○	△	
	MARK→CLEAR	○	○	○	○	○	○	○	△	
	CLEAR	○	○	○	○	○	○	○	△	
	SIZE	△	△	△	△	△	△	△	△	
SYSTEM	RANGE	○	○	○	○	○	○	○	△	
	PRESET	△	△	△	△	△	△	△	△	
	USER-UNIT	○	○	○	○	○	○	○	△	
	LOAD	○	○	○	○	○	○	○	△	
	EXT-AM	○	○	○	○	○	○	○	△	
	EXT-ADD	○	○	○	○	○	○	○	△	
	Φ SYNC	△	△	△	△	△	△	△	△	
	POWER-ON	○	○	○	○	○	○	○	△	
	REMOTE	△	△	△	△	△	△	△	△	
	DUTY-VALID	○	○	○	○	○	○	○	△	Valid when FUNCTION = ┌ (variable duty)
SYNC OUT	○	○	○	○	○	○	○	△		
CH 1/CH 2		○	○	○	○	○	○	○	×	
CH 1, CH 2 OUT		○	○	○	○	○	○	○	△	

■ Channel selection ()

Channel selection for setting and display is described.

Procedure:

Each time that the  key is pressed, the lamp that lights or flashes changes as shown below:

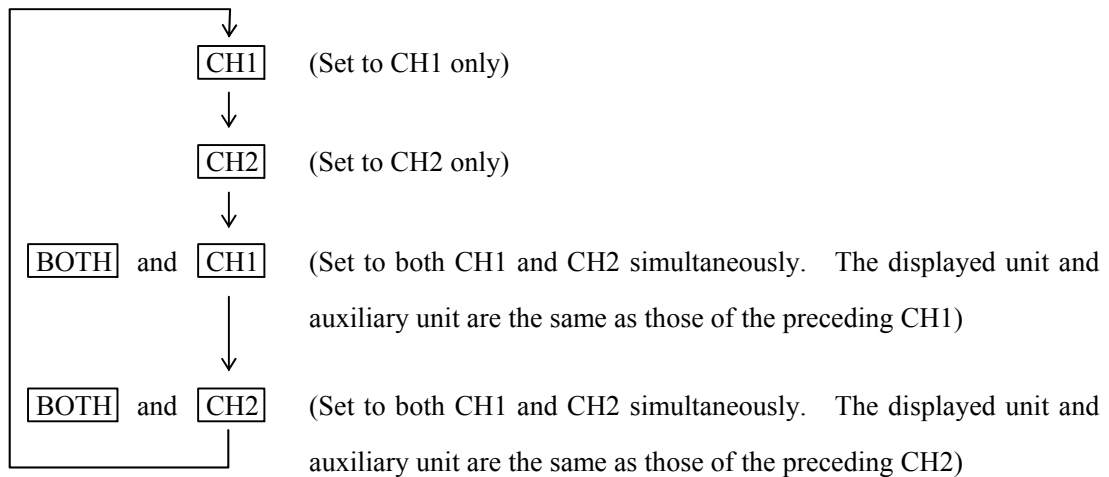

While **CH1** is flashing, however, the value of CH2 is different from the displayed value. Also, while **CH2** is flashing, the value of CH1 is different from the displayed value. If set again, CH1 and CH2 will operate with the same setting.

Operation:

In this example, CH1 is selected.

- ① Press the  key to where the **CH1** lamp above the key lights.

This selects the setting and display for CH1.

Each time the key is pressed, the setting and display change as follows: CH1 → CH2 → CH1
BOTH → CH2 BOTH → CH1...





Other:

The channel cannot be selected when the channel mode is DIFF.





■ Oscillation mode selection ()

Oscillation mode (continuous, burst, sweep, etc.) selection is described.

Terms:

NORMAL (continuous):	Continuous oscillation; normally use this mode.
BURST :	Intermittent oscillation (BURST, TRIG, GATE, T-GATE)  “4.1 Burst oscillation”, cf.
SWEEP :	Item such as frequency is automatically varied.  “4.2 Sweep”, cf.
MODU (modulation) :	Modulated waveform output (FM, AM, OFSM, PM, PWM)  “4.3 Modulation”, cf.
NOISE :	White noise output
DC :	DC output  “3.3 Basic operation (■DC offset setting)”, cf.



Operation:

The selected oscillation mode is indicated in the STATUS area, which is located to the left of  key. When the  key is pressed, the  key lamp lights, and at the same time, the lamp of every key located to the right of the  key lights.

To use another oscillation mode (one whose key lamp is already lit), press the key of the mode.

Operation example:

In this example, first set to DC, then to continuous (NORMAL).

- ① Press the  key, then the  key to set the DC mode.

The DC STATUS lamp lights.







- ② Press the  key, then the  key to set the NORMAL mode.

The NORMAL STATUS lamp lights.





■ Waveform selection ()

Waveform selection is described.

Symbols:



-  : Sinewave
-  : Triangular wave
-  : Squarewave (50 % fixed duty)
-  : Squarewave (variable duty)
-  : Rising sawtooth
-  : Descending sawtooth
- ARB: Arbitrary waveform
-  4.4 Arbitrary Waveform (ARB)

Operation:

The selected waveform is indicated in the STATUS area, which is located to the left of  key. When the  key is pressed, the  key lamp lights, and at the same time, the lamp of every key located to the right of the  key lights. The lamp of the selected waveform blinks. To select another waveform (one whose key lamp is already lit), press the key of the waveform.

Operation example:

In this example, a triangular waveform is selected.

- ① Press the  key, then the  key.

The  STATUS lamp lights

- ② After selecting, press the  key once to exit the setting mode.

Other:

Waveforms cannot be selected in the following cases:

- The oscillation mode is NOISE or DC.
- The oscillation mode is SWEEP and the type is DUTY.
- The oscillation mode is MODU and the type is PWM.

■ Frequency setting (→)

Frequency (FREQ) setting is described.



Operation:

Two methods can be used for setting the frequency.

(1) Keypad



This method is convenient when the frequency has been determined beforehand.

For example, set 1 kHz as follows.

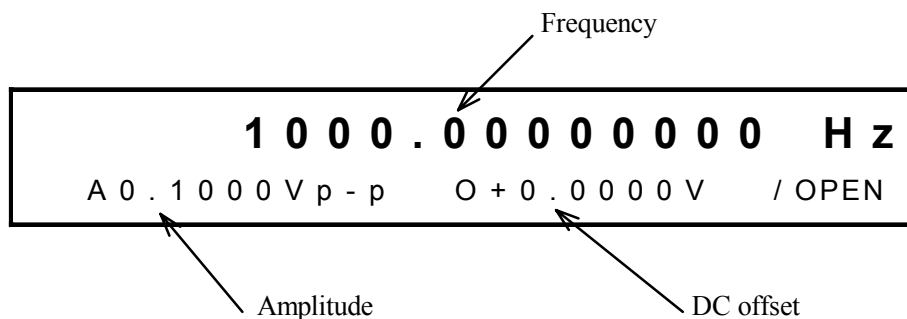
- ① Press the  key, then the  key.









- ② Press the  key, then the  key.

If the number was entered incorrectly, press the  key before pressing the  key.





- ③ After setting, press the  key to exit the setting mode.

(2) Modify dial

This is convenient for continuously setting the frequency.

- ① Press the  key, then the  key.
- ② Select the digit to be changed with the  and  keys. The selected digit flashes.
- ③ Turn the  dial to set the digit.
- ④ After setting, press the  key.

Other:

- The frequency cannot be set in the **NOISE** or **DC** oscillation modes.
- When keys such as  are not being used for industrial units (e.g., 50 Hz), press the  key directly after entering the frequency.  "5.2 Units", cf.
- The frequency generating period can also be set.
 "5.1 Convenient Settings (■Frequency [Hz] setting by period [s])", cf.

■ Amplitude setting (→)

Amplitude (AMPTD) setting is described.



Operation:

The amplitude can be set by two methods.

(1) Keypad





Convenient when the amplitude has been determined beforehand.

For example, set 2 Vp-p as follows.

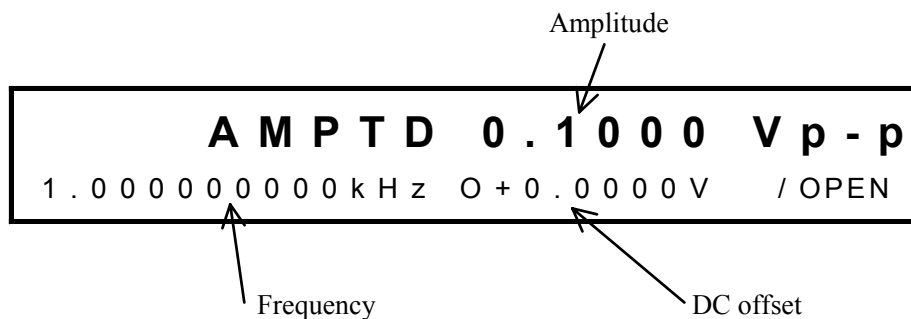
- ① Press the  key, then the  key.







The following display is produced.





- ② Press the  key, then the  key.
To correct an entry, press the  key before pressing  key.
- ③ This completes setting, afterwards, press the  key.

(2) Modify dial

The amplitude can be changed continuously.

- ① Press the  key, then the  key.
- ② Select the digit to be changed with the  and  keys.
- ③ Turn the  dial to set the flashing digit.
- ④ After setting, press the  key to release the setting mode.

Other:

- When the oscillation mode is DC, the amplitude cannot be set.
- Units other than Vp-p can also be set.  "5.2 Units (■Amplitude units change)", cf.
- When the oscillation mode is NOISE, the output amplitude becomes half the set amplitude as a result of the Vp-p setting only. Effective values in NOISE mode are the same as the effective values of the 15-MHz models, such as the WF1946, with the same amplitude setting.
- Can also be set by waveform high level and low level.
 "5.1 Convenient Settings (■Amplitude and DC offset setting by high and low level)", cf.

■ DC offset setting (→)

DC offset determines the offset component added to the waveform or the output voltage when the oscillation mode is DC.

Setting the DC offset (OFFSET) is described.



Operation:

Two methods can be used for setting the DC offset.

(1) Keypad





Convenient when the DC offset has been determined beforehand.

For example, set +1 V as follows.

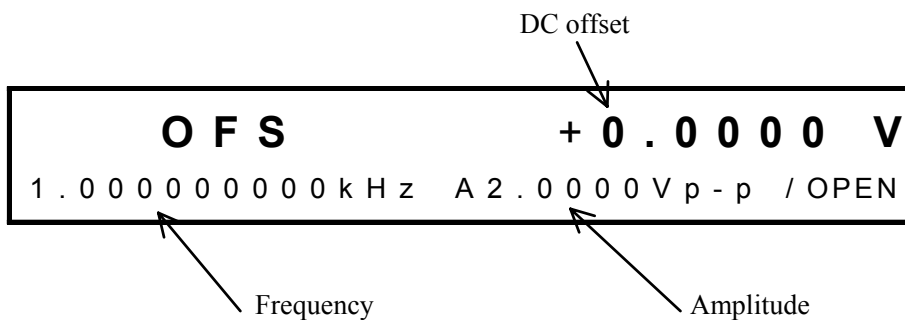
- ① Press the  key, then the  key.







The following display is produced.



- ② Press the  key, then the  key.
To correct an entry, press the  key before pressing .
- ③ This completes setting, afterwards, press the  key.

(2) Modify dial

The offset can be changed continuously.

- ① Press the  key, then the  key.
- ② Select the digit to be changed with the  and  keys.
- ③ Turn the  dial to set the flashing digit.
- ④ After setting, press the  key to release the setting mode.

Other:

- Can also be set by waveform high level and low level.

 "5.1 Convenient Settings (■ Amplitude and DC offset setting by high and low level)", cf.

■ Phase setting (→)

The oscillation starting phase setting for burst and (gated) sweep is described.

Set CH1 and CH2 independently to also allow setting the phase difference between these channels.

 "5.5 Other settings (■Phase sync)", cf.



Operation:

Two methods can be used for setting the phase.

(1) Keypad





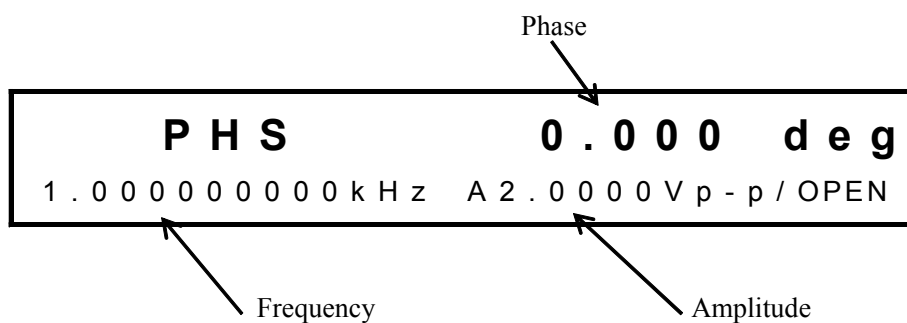

Convenient when the phase has been determined beforehand.

For example, set 90 degrees as follows.

- ① Press the  key, then the  key.







The following display is produced.



- ② Press keys  and , then the  key.
To correct an entry, press the  key before pressing .
- ③ This completes setting, afterwards, press the  key.

(2) Modify dial

The phase can be changed continuously.

- ① Press the  key, then the  key.
- ② Select the digit to be changed with the  and  keys.
- ③ Turn the  dial to set the flashing digit.
- ④ After setting, press the  key to release the setting mode.

■ Squarewave rise time/fall time setting (tr/tf) (→)

Operation to set the rise time/fall time of squarewaves is described.

The rise time/fall time setting controls the time during which the voltage changes from 10% to 90% on the assumption that the range of output voltage excluding overshoots from the low level to the high level is set to 100%. The example assumes that a squarewave (including variable duty) is selected as the waveform.



Operation:

Two methods can be used for setting the squarewave rise time/fall time:

(1) Keypad





This method is convenient when the values have been determined beforehand.

For example, set 100 ns as follows.

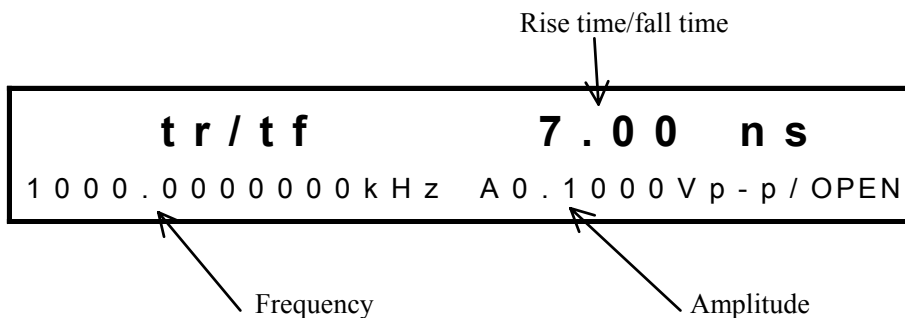
- ① Press the  key, then the  key.

The following display is produced.









- ② Press the , , and  keys, and then the  key (The input of 0.1 μs is converted into 100 ns).

To correct an entry, press the  key before pressing .

- ③ This completes setting, afterwards, press the  key.

(2) Modify dial

This method is convenient when the values to be set change continuously.

- ① Press the  key, then the  key.
- ② Press the  and  keys. The digit to be changed flashes.
- ③ Turn the  dial to increase/decrease the value of the flashing digit.
- ④ After setting, press the  key to release the setting mode.



Other:

- Switching the stop level to ON disables the rise time/fall time setting.
- The range of the rise time/fall time setting may be limited because of the frequency, period, pulse width, and duty settings. If any of these settings is changed, the rise time/fall time may change accordingly.

■ Output on/off

Output on/off setting is described.

Operation:

- ① Press the  ,  key. The setting alternates between on and off each time the key is pressed.

The lamp lights when on, extinguishes when off.

Other:

When the channel mode is DIFF or BOTH does not light, each channel operates independently.

When the channel mode is DIFF or BOTH lights, the outputs of both channels are linked (Both outputs become on/off with any CH1 OUT or CH2 OUT operation).

■ **Operation tree**

CH 1 OUT / CH 2 OUT
 ON/OFF / ON/OFF — Output on/off

CHANNEL MODE — Channel mode [INDEP/2PHASE/2TONE/RATIO/DIFF]

CH 1/CH 2 — Channel selection [CH 1/CH 2/BOTH CH1/BOTH CH2]

MODE — Oscillation mode
 L NORMAL / BURST / SWEEP / MODU / NOISE / DC

BURST Menu
 — TYPE (Burst type) [BURST/TRIG/GATE/T-GATE]
 — SOURCE (Trigger/gate source selection)
 — DELAY (Trigger delay) * For TYPE: TRIG
 — MARK (Number of times signal present) * For TYPE: BURST/TRIG
 — SPACE (Number of times signal not present) * For TYPE: BURST
 — STOP-LEVEL (Stop level)
 — OPER-COMMON (Simultaneous operation of both channels)
 * When the same TYPE is set for both channels

BURST Operation
 L MAN TRIG

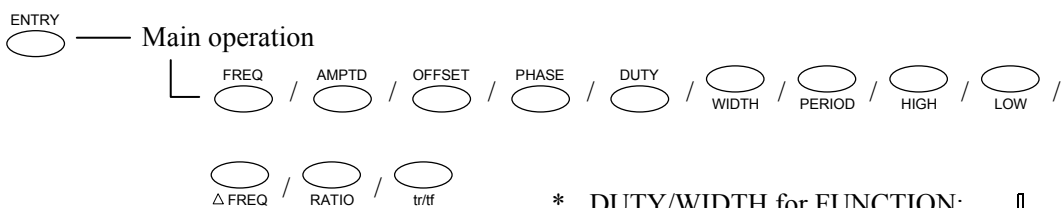
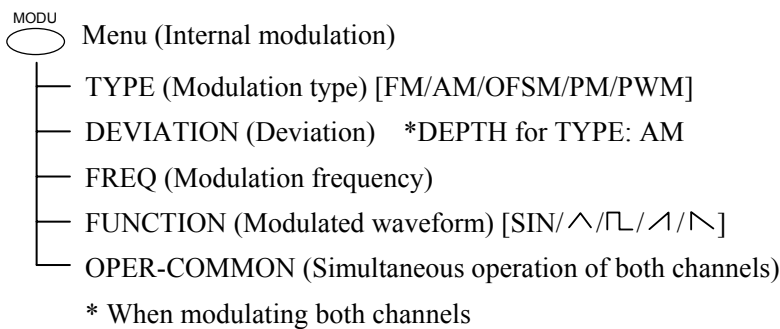
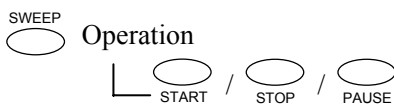
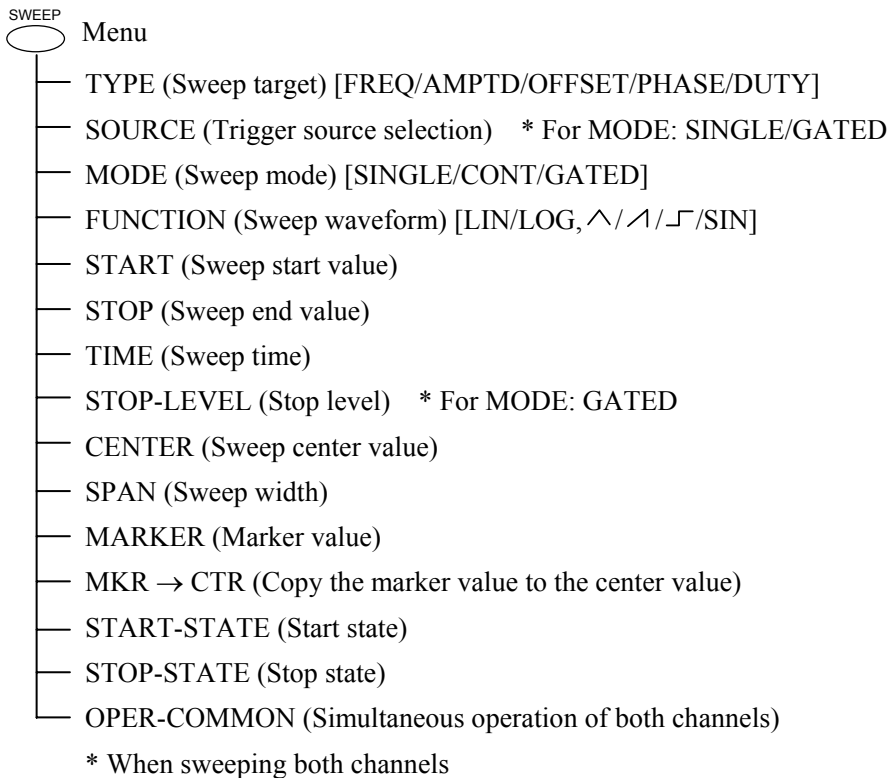



* DUTY/WIDTH for FUNCTION:

Δ FREQ is for CHANNEL MODE: 2TONE

RATIO is for CHANNEL MODE: RATIO

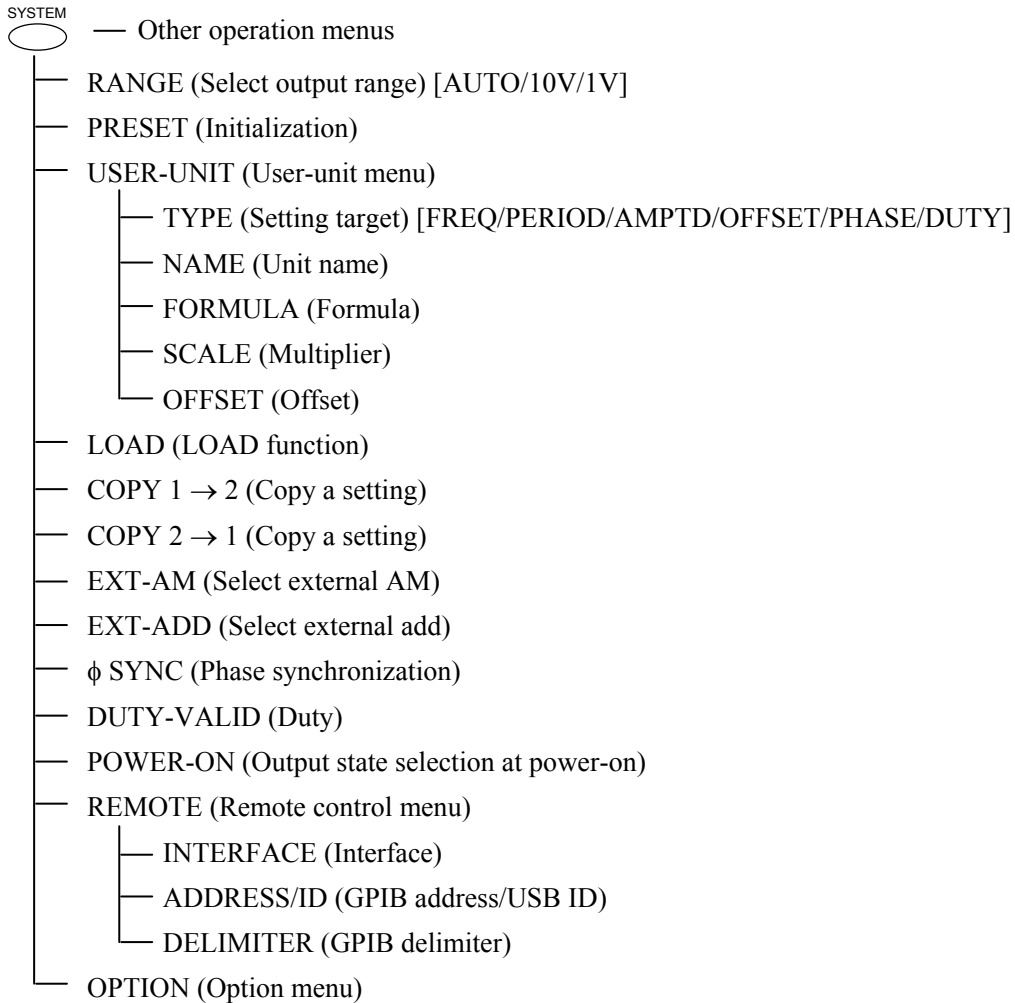
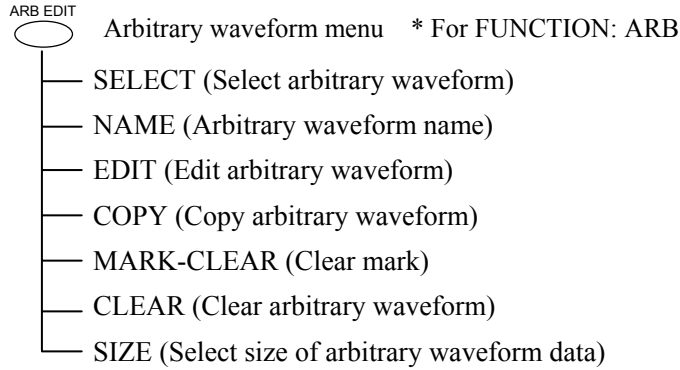
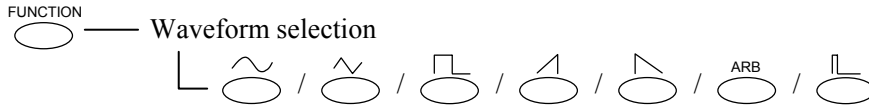
tr/ff for FUNCTION: or





MEMORY
 Setup memory menu

- STORE (Save setup memory)
- RECALL (Call setup memory)
- CLEAR (Clear setup memory)

 LOCAL (Return to local of GPIB)

UNDO
 (Cancel setting)

EXIT
 (Move to menu immediately above)

ENTER
 (Accept input value)

Numeric input (keypad)

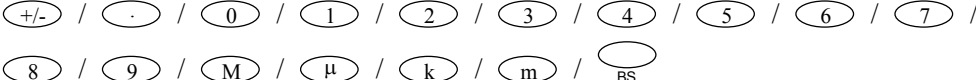

Numeric modification (Modify)



Section 4 Applications

4.1	Burst oscillation	4-2
■	Burst oscillation (Type: Burst)	4-2
■	Burst oscillation (Type: Trigger)	4-5
■	Burst oscillation (Type: Gate)	4-9
■	Burst oscillation (Type: Triggered Gate)	4-10
4.2	Sweep	4-10
■	Sweep (Mode: Single)	4-10
■	Sweep (Mode: Continuous)	4-10
■	Sweep (Mode: Gated)	4-10
■	CENTER, SPAN, MARKER, MKR → CTR	4-10
■	Summary of the sweep setting items	4-10
■	Sweep (Modulation) steps and step width	4-10
■	Sweep value and marker/sync/X-DRIVE output	4-10
4.3	Modulation	4-10
■	Frequency modulation (FM)	4-10
■	Amplitude modulation (AM)	4-10
■	DC offset modulation (OFSM)	4-10
■	Phase modulation (PM)	4-10
■	Pulse width modulation (PWM)	4-10
4.4	Arbitrary Waveform	4-10
■	Arbitrary waveform (ARB)	4-10
4.5	Selecting waveforms of synchronous signals (SYNC OUT)	4-10
■	Procedure	4-10
■	When the oscillation mode is BURST	4-10
■	When the oscillation mode is SWEEP	4-10
■	When the oscillation mode is MODU	4-10
■	Additional information:	4-10
4.6	Output waveforms for sweeping and modulation	4-10
4.7	Equivalent noise bandwidth	4-10

• Following is an example of the display when using this section.

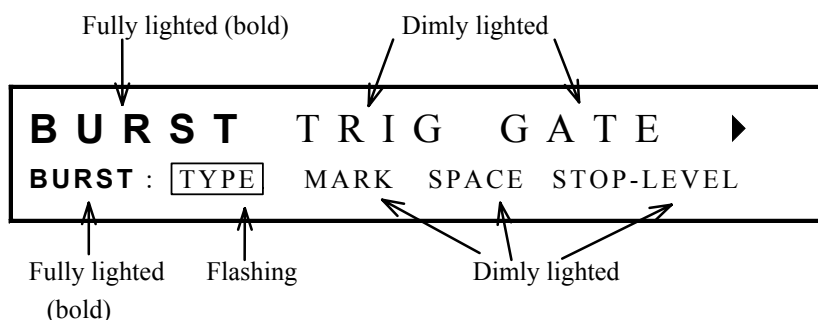

4.1 Burst oscillation

■ Burst oscillation (Type: Burst) (→ → TYPE : BURST)

Burst oscillation (Type: Burst) produces an intermittent oscillation at the designated oscillation cycle and stop cycle.

Operation is described with reference to an example of producing a waveform output such as indicated in the figure.

In this example, the waveform is triangular, the DC offset is set to 0 V, the oscillation start phase is set to 0 degrees, and the frequency and amplitude are set to arbitrarily defined values.

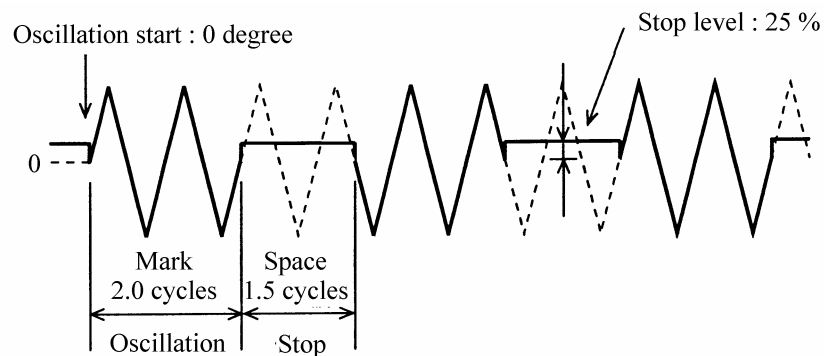

Operation:

(1) Set the burst oscillation TYPE to BURST.

- ① Press the key, then the key.
- ② Use the and keys to select the type (TYPE flashes).

```

BURST TRIG GATE ▶
BURST : TYPE MARK SPACE STOP-LEVEL
    
```

- ③ Press the key, then produce the following display with the and keys (BURST flashes).

```



BURST TRIG GATE ▶
BURST : TYPE MARK SPACE STOP-LEVEL
    
```

- ④ This sets the burst oscillation type to burst. Press the key once to exit type setting.

(2) Set MARK cycle

- ① Use the ◀ and ▶ keys to produce the following display (MARK flashes).

				1 . 0	c y c l e
BURST :	TYPE	MARK	SPACE	STOP-LEVEL	

- ② Press the  key.
- ③ Set the mark cycles with the keypad or  dial (0.5 cycles).



In this example, the setting is 2.0 cycles.

- ④ After setting, press the  key once to exit mark cycle setting.

(3) Set SPACE cycle

- ① Use the ◀ and ▶ keys to produce the following display (SPACE flashes)

				1 . 0	c y c l e
BURST :	TYPE	MARK	SPACE	STOP-LEVEL	

- ② Press the  key.
- ③ Set the space cycles with the keypad or  dial (0.5 cycles). In this example, the setting is 1.5 cycles.
- ④ After setting, press  once to exit space cycle setting.

(4) Set STOP-LEVEL



- ① Use the ◀ and ▶ keys to produce the following display (STOP-LEVEL flashes).

OFF				
BURST :	TYPE	MARK	SPACE	STOP-LEVEL

② Press the  key.

Turn the  dial to produce the following display (ON flashes).



③ Press the  key, then set the stop level with the keypad or  dial.

In this example, the setting is 25 %.



The stop level is the percentage with respect to the maximum positive (+100 %) and negative (-100 %) amplitude.

④ After setting, press the  key to release the setting mode.

This completes burst oscillation (type: burst) setting.

Other:

- If the frequency exceeds 5 MHz, mark cycles and space cycles may be unpredictable. If the cycles are undefined, the start phase may be shifted by half a cycle even though the frequency is set to less than 5 MHz. If such a shift occurs, set the continuous oscillation and then the burst oscillation.

- Stop level off: Oscillation stops at the phase (set by  → ) setting (mark cycles more than 1.0 and mark + space cycles are integers).

Waveform example of oscillation start phase: -90° , mark waves: 2, space waves: 1

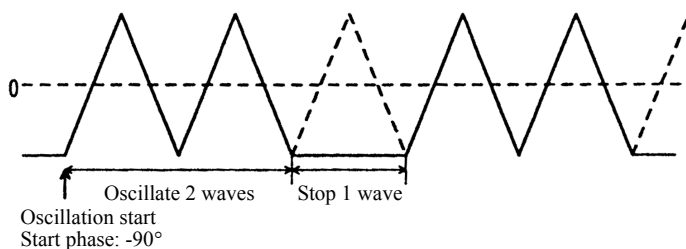

*Also, by setting an amplitude (V_{p-p}) 1/2 DC offset or the low level to 0 V, a unipolar waveform can be obtained.

 “5.1 Convenient Settings (■ Amplitude and DC offset setting by high and low level)”, cf.

- Burst oscillation setting items (BURST menu)
 - TYPE: BURST
 - MARK (oscillation cycle) [cycle]
 - SPACE (cycle when oscillation stops) [cycle]
 - STOP-LEVEL [OFF, ON[%]]
 - PHASE (phase when oscillation starts) [deg] * ENTRY menu

■ Burst oscillation (Type: Trigger) (MODE → BURST → TYPE : TRIG)

Burst oscillation (Type: Trigger) produces an intermittent oscillation output at a designated cycle at each trigger signal.

Operation is described with reference to an example of producing a waveform output such as indicated in the figure in response to an external trigger ($\sqrt{\quad}$).

The example is a triangular waveform, DC offset 0 V, oscillation start phase 0 degrees, frequency and amplitude arbitrary.

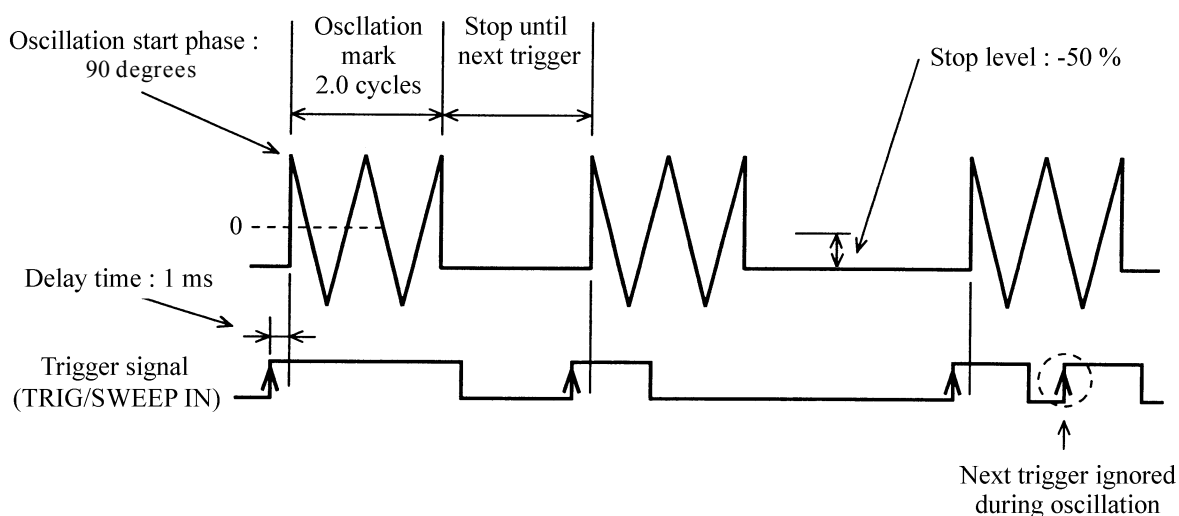

Operation:

(1) Set the burst oscillation TYPE to TRIG.

- ① Press the MODE key, then the BURST key.
- ② Use the LEFT and RIGHT keys to select the type (TYPE flashes).

```

B U R S T   T R I G   G A T E   ▶
BURST : TYPE MARK SPACE STOP-LEVEL

```

- ③ Press the ENTER key, then produce the following display with the LEFT and RIGHT keys (TRIG flashes).



```

B U R S T   T R I G   G A T E   ▶
BURST : TYPE SOURCE DELAY MARK ▶





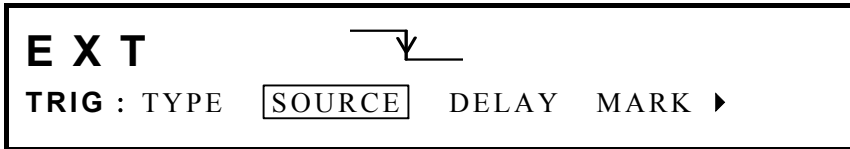

```

- ④ This sets the burst oscillation type to trigger. Press the EXIT key to exit type setting.



(2) Select trigger SOURCE

- ① Use the  and  keys to produce the following display (SOURCE flashes).





- ② Press the  key.
- ③ Press the  key, then turn the  dial to select rising trigger ().
( indicates falling trigger).
- ④ After setting, press the  key once to release trigger source setting.



(3) Set DELAY time

- ① Use the  and  keys to produce the following display (DELAY flashes).



- ② Press the  key.
- ③ Set the delay time with the keypad or  dial.
For example, set to 1 ms.
- ④ After setting, press the  key once to release delay time setting.

(4) Set MARK cycle

- ① Use the  and  keys to produce the following display (MARK flashes).



The screenshot shows a rectangular display area. At the top, the text "1.0 cycle" is displayed in a large font. Below it, the text "TRIG : TYPE SOURCE DELAY MARK" is shown, with "MARK" highlighted in a box and a right-pointing arrow next to it.



- ② Press the  key.

Set the mark cycles with the keypad or  dial (0.5 cycles).

In this example, the setting is 2.0 cycles.

- ③ After setting, press the  key once to release mark cycle setting.

(5) Set STOP-LEVEL

- ① Use the  and  keys to produce the following display (STOP-LEVEL flashes).





The screenshot shows a rectangular display area. At the top, the text "OFF" is displayed in a large font. Below it, the text "TRIG : ◀ STOP-LEVEL" is shown, with "STOP-LEVEL" highlighted in a box and a left-pointing arrow next to it.

- ② Press the  key.

Turn the  dial to produce the following display (ON flashes).



The screenshot shows a rectangular display area. At the top, the text "ON" is displayed in a large font, with "ON" highlighted in a box. To the right, the text "0.00%" is displayed. Below it, the text "TRIG : ◀ STOP-LEVEL" is shown, with "STOP-LEVEL" highlighted in a box and a left-pointing arrow next to it.



- ③ Press the  key, then set the stop level with the keypad or  dial.

In this example, the setting is -50 %.

The stop level is the percentage with respect to the maximum positive (+100 %) and negative (-100 %) amplitude.

- ④ After setting, press the  key to release the setting mode.

(6) Phase setting

- ① Press the  key, then the  key
- ② Set the phase with the keypad or  dial.

For example, set the phase to 90 degrees.





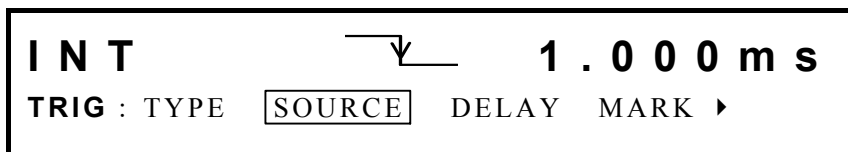

- ③ After setting, press the  key to release the setting mode.

The above sets burst oscillation (type: trigger). Oscillation is produced when a signal () is applied to the TRIG/SWEEP IN connector.

Additional information:

- **Internal trigger** : A trigger signal of 50% duty is generated at the following trigger cycle for oscillation/stop.
The trigger rate is common for CH1 and CH2.



- **Stop level off** : Oscillation stops at the phase (set by  → ) setting (mark cycle is integer).
 - **Manual trigger** : Press the  key, then set the trigger source to EXT . Operation is based on the logical OR of the external signal, key, and type of remote control (GPIB or USB).
 - **To generate the trigger signal via remote control (GPIB or USB)**, set the GET command or TRG command from the remote control interface.
Also, set the trigger source to EXT .
- For details of the remote control command,  “Remote Control Instruction Manual”, cf.

- To simultaneously generate a trigger signal for both channels manually or via remote control (GPIB or USB), set Type for both channels to Trigger and set OPER-COMMON to on. If the BOTH lamp is on, behavior is the same even though OPER-COMMON is off.



- Burst oscillation (type: trigger) setting items (BURST menu)

TYPE: TRIG

SOURCE (trigger source) CH1: [EXT \downarrow , EXT \uparrow , INT \downarrow [s], INT \uparrow [s]]

CH2: [EXT CH2 \downarrow , EXT CH2 \uparrow , EXT CH1 \downarrow ,
EXT CH1 \uparrow , INT \downarrow [s], INT \uparrow [s]]

DELAY (trigger delay) [s]

MARK (oscillation cycle) [cycle]

STOP-LEVEL (stop level) [OFF, ON[%]]

OPER-COMMON (trigger in both channels) [OFF, ON]

PHASE (phase when oscillation starts) [deg] * ENTRY menu

■ Burst oscillation (Type: Gate) ($\text{MODE} \rightarrow \text{BURST} \rightarrow \text{TYPE : GATE}$)

Burst oscillation (Type: Gate) is intermittent with start and stop according to the trigger signal level.

Operation is described with reference to an example of producing a waveform output such as indicated in the figure in response to an external gate signal.

The example is a triangular waveform, DC offset 0 V, oscillation start phase 0 degrees, frequency and amplitude arbitrary.

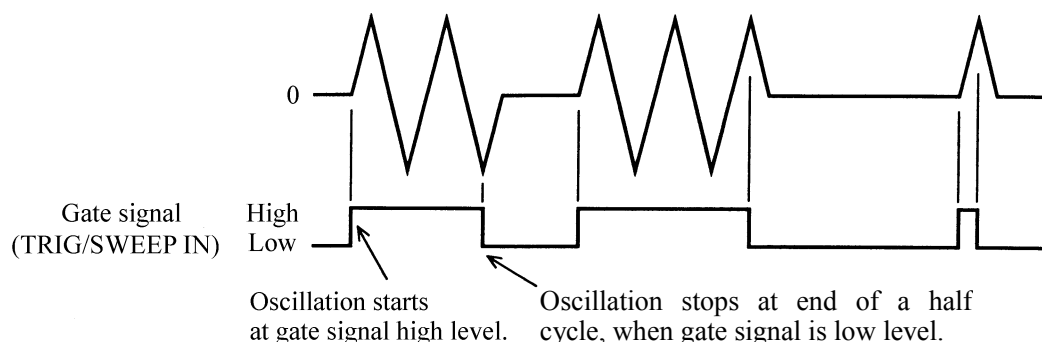

Operation:**(1) Set burst oscillation TYPE to GATE.**

- ① Press the ^{MODE} key, then the ^{BURST} key.
- ② Use the ◀ and ▶ keys to produce the following display (TYPE flashes).

BURST TRIG GATE ▶ BURST : TYPE MARK SPACE STOP-LEVEL

- ③ Press the ^{ENTER} key, then produce the following display with the ◀ and ▶ keys (GATE flashes).

BURST TRIG GATE ▶ GATE : TYPE SOURCE STOP-LEVEL
--

- ④ This sets the burst oscillation type for gate.
Press the ^{EXIT} key once to release the type setting mode.



(2) Select gate SOURCE

- ① Use the ◀ and ▶ keys to produce the following display (SOURCE flashes).

EXT L - ON GATE : TYPE SOURCE STOP-LEVEL



- ② Press the ^{ENTER} key.
- ③ Press the ▶ key, then select positive logic (H-ON) with the ^{MODIFY} dial.
- ④ After setting, press the ^{EXIT} key to release the setting mode.

(3) Set STOP-LEVEL

- ① Use the  and  keys to produce the following display (STOP-LEVEL flashes).



```

OFF
GATE : TYPE SOURCE STOP-LEVEL
  
```

- ② Press the  key.
Turn the  dial to produce the following display (ON flashes).

```

ON                                0.00%
GATE : TYPE SOURCE STOP-LEVEL
  
```

- ③ Press the  key, then set the stop level with the keypad or  dial.
In this example, the setting is 0 %.

The stop level is the percentage with respect to the maximum positive (+100 %) and negative (-100 %) amplitude.

- ④ After setting, press the  key to release the setting mode.

The above selects sets burst oscillation (type: gate). Oscillation occurs when a high level signal is applied to the TRIG/SWEEP IN connector. If the connection is open, oscillation continues due to internal pullup.

Other settings:

- At the above settings, when the waveform is squarewave, a three squarewave is obtained such as shown in the following figure.

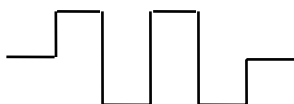



(When stop level is off, the oscillation stops at either high or low level.)

- Internal gate source** : A 50 % duty gate signal is generated at the following period for oscillation start/stop. The gate rate is common for CH1 and CH2.

```

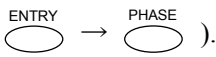
INT                                L - ON  1.000ms
GATE : TYPE SOURCE STOP-LEVEL
  
```

- **Stop level off** : Oscillation stops at the half-cycle after gate signal off (i.e., at the phase set by ).
- **Manual gate signal** : Press the  key. The gate signal is on (i.e., oscillation) while the key is pressed. In this case, set the trigger source for EXT L-ON.
- **To generate the trigger signal via remote control (GPIB or USB)**, set the GET command or TRG command from the remote control interface.
Also, set the trigger source to EXT L-ON.
For details of the remote control command,  “Remote Control Instruction Manual”, cf.
- **To simultaneously generate a gate signal for both channels manually or via remote control (GPIB or USB)**, set Type for both channels to Gate and set OPER-COMMON to on.
If the BOTH lamp is on, behavior is the same even though OPER-COMMON is off.



- Burst oscillation (type: gate) setting items (BURST menu)
 - TYPE: GATE
 - SOURCE (trigger source)
 - CH1: [EXT L-ON, EXT H-ON, INT L-ON [s], INT H-ON [s]]
 - CH2: [EXT CH2 L-ON, EXT CH2 H-ON, EXT CH1 L-ON, EXT CH1 H-ON, INT L-ON [s], INT H-ON [s]]
 - STOP-LEVEL [OFF, ON [%]]
 - OPER-COMMON (simultaneous gate generation for both channels) [OFF, ON]
 - PHASE (phase when oscillation starts) [deg] * ENTRY menu

■ Burst oscillation (Type: Triggered Gate) (MODE → BURST → TYPE : T-GATE)

Burst oscillation (Type: Triggered Gate) is intermittent with repeated start and stop at each trigger signal.

Operation is described with reference to an example of producing a waveform output such as indicated in the figure in response to an external trigger (\square).

The example is a triangular waveform, DC offset 0 V, oscillation start phase 0 degrees, frequency and amplitude arbitrary.

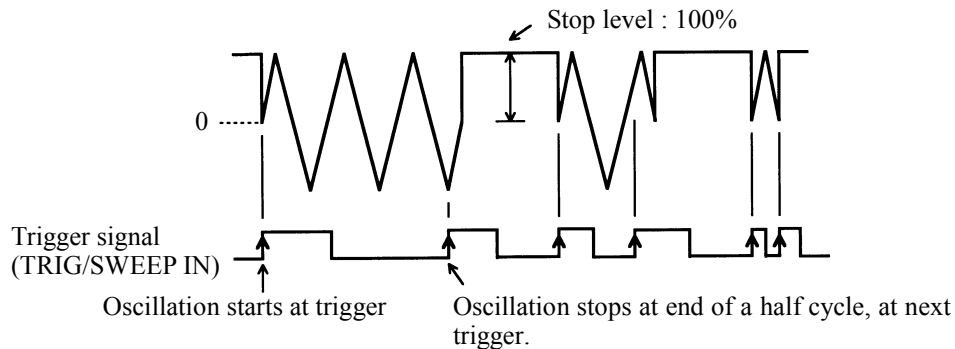

Operation:

(1) Set burst oscillation TYPE to trig'd gate (T-GATE)

- ① Press the MODE key, then the BURST key.
- ② Use the \leftarrow and \rightarrow keys to produce the following display (TYPE flashes)

```

B U R S T   T R I G   G A T E  ▶
BURST : TYPE  MARK  SPACE  STOP-LEVEL
```

- ③ Press ENTER key, then use the \leftarrow and \rightarrow keys to produce the following display (T-GATE flashes).

```





◀ T - G A T E
T-GATE : TYPE  SOURCE  STOP-LEVEL
```

- ④ This sets the burst oscillation type for triggered gate. Press the EXIT key once to release the type setting mode.



(2) Select trigger source (SOURCE)

- ① Use the  and  keys to produce the following display (SOURCE flashes).





- ② Press the  key.
- ③ Select rising () using the  dial. ( indicates falling of the trigger signal)
- ④ After making a selection, press the  key once to exit the trigger source selection.



(3) Set STOP-LEVEL

- ① Use the  and  keys to produce the following display (STOP-LEVEL flashes).





- ② Press the  key.
- ③ Turn the  dial to produce the following display (ON flashes).



- ④ Press the  key, then set the stop level with the keypad or  dial. For example, set to 100 %.

The stop level is the percentage with respect to the maximum positive (+100 %) and negative (–100 %) amplitude.

- ⑤ After setting, press the  key to release the setting mode.

The above sets the burst oscillation (type: triggered gate). Oscillation alternates between start and stop each time a signal () is applied to the TRIG/SWEEP IN connector.

Other settings:

- **Stop level off** : Oscillation stops after the trigger signal is applied, at the end of a half cycle (i.e., at the phase set by $\text{ENTRY} \rightarrow \text{PHASE}$) or plus 180 degrees from that phase.

- **Manual trigger** : When a manual trigger signal is desired, press the MAN TRIG key. Oscillation starts and stops each time the key is pressed.

The trigger input and MAN TRIG operations operate in parallel. If oscillation is started by either of them, the output becomes oscillation. This oscillation cannot be stopped by the other operation.

Oscillation stops during power-on.

- **To generate the trigger signal via remote control (GPIB or USB)**, set the GET command or TRG command from the remote control interface.

Also, set the trigger source to EXT \uparrow .

For details of the remote control command,  "Remote Control Instruction Manual", cf.

- **To simultaneously generate a signal for both channels manually or via remote control**, set Type for both channels to Trigger and set OPER-COMMON to on.

If the BOTH lamp is on, behavior is the same even though OPER-COMMON is off.



- Burst oscillation (type: triggered gate) setting items (BURST menu)

TYPE: T-GATE

SOURCE (trigger source) CH1: [EXT \downarrow , EXT \uparrow]

CH2: [EXT CH2 \downarrow , EXT CH2 \uparrow , EXT CH1 \downarrow ,
EXT CH1 \uparrow]

STOP-LEVEL (stop level) [OFF, ON[%]]

OPER-COMMON (trigger in both channels) [OFF, ON]

PHASE (phase when oscillation starts) * ENTRY menu

4.2 Sweep



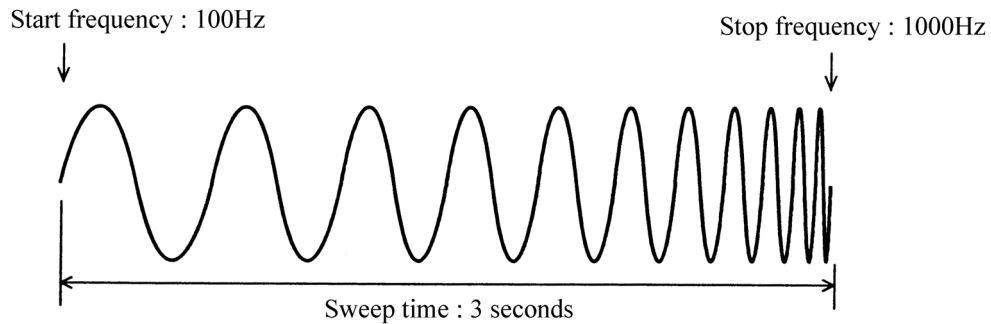

■ Sweep (Mode: Single) (→ → MODE : SINGLE)

In a Sweep (Mode: Single), oscillation occurs by varying parameters such as the frequency and amplitude one time between the start and stop settings. Oscillation continues after the sweep is completed. Operation to produce a waveform output with frequency that varies linearly and continuously is described. The setting example is a sinewave with arbitrary amplitude and DC offset.





Operation:

(1) Set sweep MODE to SINGLE

- ① Press the  key, then the  key.
- ② Use the  and  keys to produce the following display (MODE flashes).

```

S I N G L E C O N T G A T E D
F-SWP : TYPE SOURCE MODE ▶
    
```

- ③ Press  , then use the  and  keys to produce the following display (SINGLE flashes).

```

S I N G L E C O N T G A T E D
F-SWP : TYPE SOURCE MODE ▶
    
```

- ④ This sets the sweep mode for single. Press the  key once to release mode select.

(2) Set the sweep TYPE to FREQ

- ① Use the ◀ and ▶ keys to produce the following display (TYPE flashes).

```

F R E Q A M P T D O F F S E T ▶
F-SWP : TYPE SOURCE MODE ▶
  
```

- ② Press the **ENTER** key, then use the ◀ and ▶ keys to produce the following display (FREQ flashes).

```

F R E Q A M P T D O F F S E T ▶
F-SWP : TYPE SOURCE MODE ▶
  
```

- ③ This sets the sweep type for frequency. Press the **EXIT** key once to release the type setting mode.

(3) Select sweep FUNCTION

- ① Use the ◀ and ▶ keys to produce the following display (FUNCTION flashes).

```



L I N  /
F-SWP : ◀ FUNCTION START STOP ▶
  
```

- ② Press the **ENTER** key.
- ③ Press the ▶ key, then select / with the **MODIFY** dial.
- ④ After selecting, press the **EXIT** key once to release the function select mode.

(4) Set START frequency

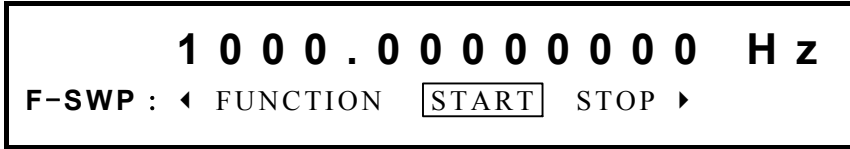
- ① Use the ◀ and ▶ keys to produce the following display (START flashes).





- ② Press  key.
- ③ Set the start frequency with the keypad or  dial.
For example, set to 100 Hz.
- ④ After setting, press the  key once to release the start frequency setting mode.

(5) Set STOP frequency

- ① Use the ◀ and ▶ keys to produce the following display (STOP flashes).





- ② Press  key.
- ③ Set the stop frequency with the keypad or  dial.
For example, set to 1000 Hz.
- ④ After setting, press the  key once to release the stop frequency setting mode.

(6) Set sweep TIME

- ① Use the ◀ and ▶ keys to produce the following display (TIME flashes).





- ② Press  key.
- ③ Set the sweep time with the keypad or  dial.

For example, set to 3 seconds.

- ④ After setting, press the  key once to release the sweep time setting mode.

(7) Sweep operation

- ① Sweep starts when the  key is pressed.

When sweep is started, an existing output frequency is quickly changed to the start frequency. If desiring to set the start frequency output beforehand, press the  key.

The output quickly changes to the start frequency, then sweeps to the stop frequency in 3 seconds (in this example). Oscillation then continues at the stop frequency.

When the  key is again pressed, sweep begins at the stop frequency and ends at the start frequency.

Other operations:

- **Sweep stop** : Press the **STOP** key. When sweep is stopped at the stop value at single sweep end or during sweep, press the **STOP** key to set the start value.
- **Sweep pause** : Press the **PAUSE** key. Again press the **PAUSE** key to resume sweep.
- **Single sweep operation examples**

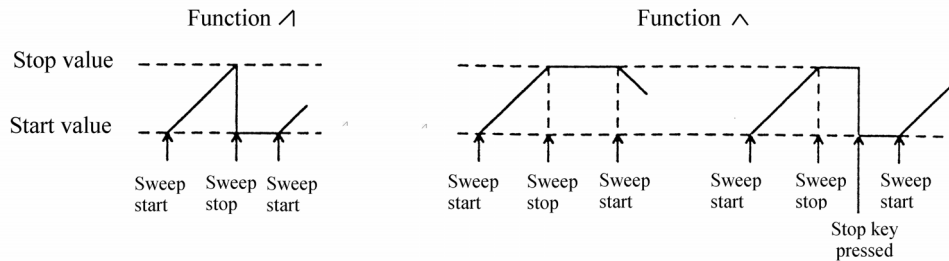

• **Dead time and trigger delay**

: Triggers input within 100 ms of completion of the last sweep are ignored. The trigger delay for the first sweep after power-on or a parameter change is 40 ms. Otherwise, it is 2 ms.

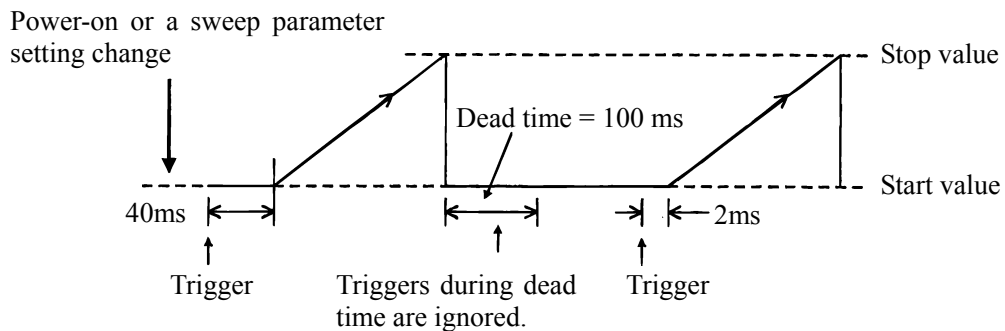

• **External sweep start**

: Set the sweep trigger source to EXT and select rising or falling. Supply an external signal to the front panel TRIG/SWEEP IN connector. However, note that retrigger cannot be applied for 100 ms after sweep start. During a sweep, the sweep restarts if a trigger is input.







• **External pause**

: Apply Low level to the rear panel SWEEP PAUSE IN connector. To resume sweep, apply a High level or open input.

- **FUNCTION** determines the sweep type.

: For example,  provides step-type change of output (e.g., frequency) at the sweep time halfway point. LIN/LOG provides linear or logarithmic variation of the output with respect to the time axis.

-  LIN
LOG
-  LIN
LOG
- 
- SIN () LIN
LOG

- **Internal sweep trigger source**

: Trigger signal of 50% duty is generated at the following trigger rate for sweep.
However, the trigger interval is 100 ms even if set to less.
The trigger rate is common for CH1 and CH2.

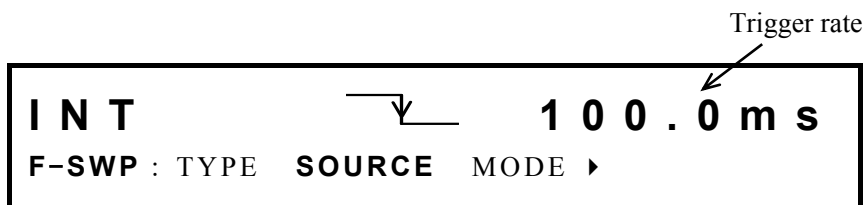

- **START-STATE and STOP-STATE** : Set output to start and stop values, respectively.

Since sweep synchronization output becomes the respective start and stop states, full-scale adjustments of the recorder and the status of external equipment can be checked. START-STATE is the same as pressing the  key (during a single sweep).

Relationship between sweep values and sweep synchronization output,  "4.2 Sweep (■ Sweep value and marker/sync/ X-DRIVE output)", cf.

- **If the sweep type (TYPE) is set to DUTY**, the output waveform is forced to become a square wave (variable duty), making it impossible to select the waveform (FUNCTION).



Multiple pulses may be output in one period during sweep, as shown below.



- During sweep, if the oscillation mode of the other channel is changed, sweep stops.

- **To generate the trigger signal via remote control (GPIB or USB)**, set the GET command or TRG command from the remote control interface.
For details of the remote control command,  “Remote Control Instruction Manual”, cf.
- **To simultaneously operate sweep (start, stop, pause, restart) for both channels manually or via remote control (GPIB or USB)**, set both channels to sweep mode and set OPER-COMMON to on.
If the BOTH lamp is on, behavior is the same even though OPER-COMMON is off.



■ **Sweep (Mode: Continuous)** ( →  → **MODE : CONT**)



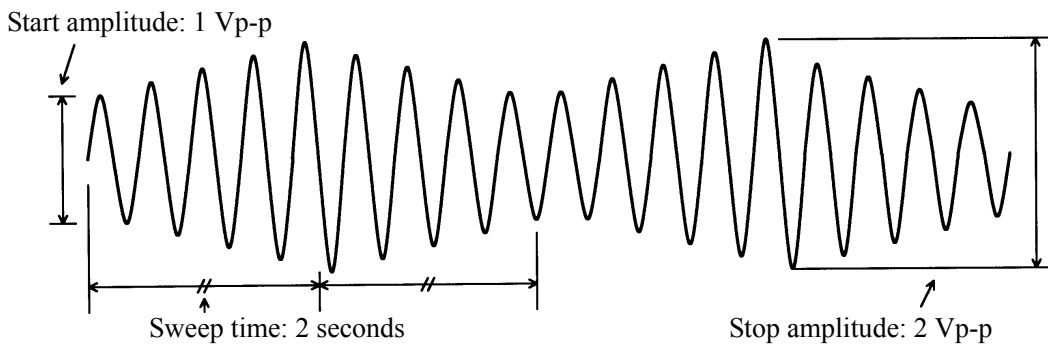

In a (Mode: Continuous), oscillation occurs by varying parameters such as the frequency and amplitude continuously between the start and stop settings.

Operation to produce a waveform output with linear and to continuously change amplitude is described. The waveform is a sinewave, and the frequency and DC offset are arbitrary.





Operation:

(1) Set sweep **MODE** to **continuous (CONT)**

- ① Press the  key, then the  key.
- ② Use the  and  keys to produce the following display (MODE flashes).



- ③ Press the  key, then use the  and  keys to produce the following display (CONT flashes).



```

S I N G L E   C O N T   G A T E D
F-SWP : TYPE  MODE  FUNCTION  START ▶

```

- ④ This completes setting the sweep mode to continuous. Press the  key once to release the setting mode.



(2) Set sweep TYPE to amplitude (AMPTD)

- ① Use the  and  keys to produce the following display (TYPE flashes).

```

F R E Q   A M P T D   O F F S E T ▶
F-SWP : TYPE  MODE  FUNCTION  START ▶

```

- ② Press the  key, then use the  and  keys to produce the following display (AMPTD flashes).



```

F R E Q   A M P T D   O F F S E T ▶
A-SWP : TYPE  MODE  FUNCTION  START ▶

```

- ③ This completes setting the sweep type to amplitude. Press the  key once to release the setting mode.





(3) Select the sweep FUNCTION

- ① Use the  and  keys to produce the following display (FUNCTION flashes).



```

L I N   ▲
A-SWP : TYPE  MODE  FUNCTION  START ▶



```

- ② Press the  key.
- ③ Press the  key, then turn the  dial to select \wedge .
- ④ After selecting, press the  key once to release the function select mode.



(4) Set the START amplitude (START)

- ① Use the  and  keys to produce the following display (START flashes).





- ② Press the  key.
- ③ Set the start amplitude with the key pad or  dial.
For example, set to 1 Vp-p.
- ④ After setting, press the  key once to release the start amplitude setting mode.

(5) Set the STOP amplitude (STOP)

- ① Use the  and  keys to produce the following display (STOP flashes).





- ② Press the  key.
- ③ Set the stop amplitude with the key pad or  dial.
For example, set to 2 Vp-p.
- ④ After setting, press the  key once to release the stop amplitude setting mode.

(6) Set the sweep TIME

- ① Use the  and  keys to produce the following display (TIME flashes).



- ② Press the  key.
- ③ Set the sweep time with the key pad or  dial.

For example, set to 2 seconds.

- ④ After setting, press the  key once to release the sweep time setting mode.





(7) Sweep operation





- ① Press the  key, then sweep starts.

If sweep is started, the amplitude output until then changes quickly to the start amplitude.

To output the start amplitude beforehand, press the  key.

Other operations:

- **Sweep stop** : Press the  key. This becomes the sweep start value.
- **Sweep pause** : Press the  key. To resume sweep, again press the  key.
- **External pause** : Apply Low level to the rear panel SWEEP PAUSE IN connector. To resume sweep, apply a High level or open input.
- **FUNCTION** : The function determines the sweep type. For example,  provides step-type change of output (e.g., frequency) at the sweep time halfway point. LIN/LOG provides linear or logarithmic variation of the output with respect to the time axis.

-  LIN
LOG
-  LIN
LOG
- 
- SIN () LIN
LOG

- **START-STATE and STOP-STATE** : Set output to start and stop values, respectively. Since sweep synchronization output becomes the respective start and stop states, full-scale adjustments of the recorder and the status of external equipment can be checked. START-STATE is the same as pressing the  key (during a continuous sweep).

Relationship between sweep values and sweep synchronization output,  “4.2 Sweep (■Sweep value and marker/sync/X-DRIVE output)”, cf.

- **If the sweep type (TYPE) is set to DUTY**, the output waveform automatically becomes a squarewave (variable duty). This makes it impossible to select the waveform (FUNCTION). Multiple pulses may be output in one cycle during sweep, as shown below.



- During sweep, if the oscillation mode of the other channel is changed, sweep stops.
- **To manually operate sweep (start, stop, pause, restart) for both channels simultaneously or to operate sweep via remote control (GPIB or USB)**, set both channels to sweep mode and set OPER-COMMON to on.



■ Sweep (Mode: Gated) (→ → **MODE : GATED**)

In a Sweep (Mode: Gated), oscillation occurs by varying parameters such as the frequency and amplitude one time between the start and stop settings. Oscillation stops before the sweep starts and when the sweep is completed.



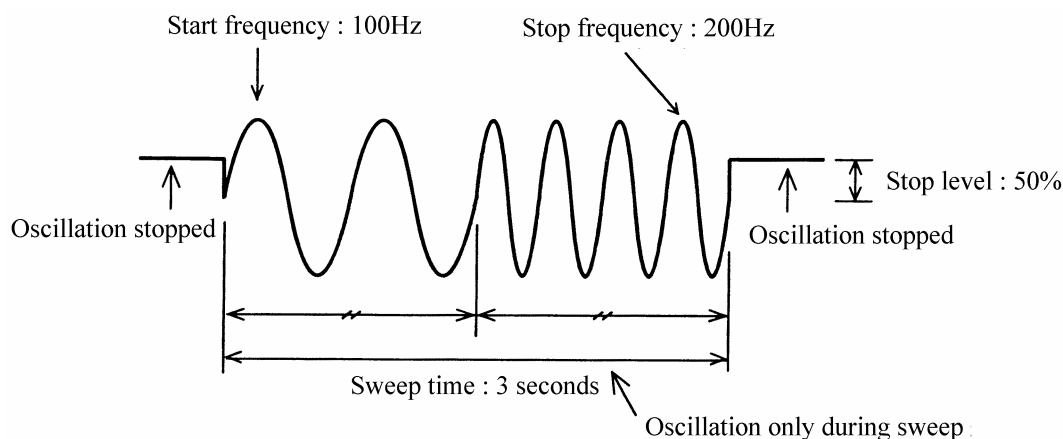

Operation to produce a waveform output with frequency that varies in step form and oscillation stops is described.

The setting example is a sinewave with arbitrary amplitude and DC offset 0.





Operation:

(1) Set sweep **MODE** to **GATED**

- ① Press the  key, then the  key.
- ② Use the  and  keys to produce the following display (MODE flashes).

```

S I N G L E   C O N T   G A T E D
F-SWP : TYPE SOURCE MODE ▶
  
```

- ③ Press the  key, then use the  and  keys to produce the following display (GATED flashes).

```

S I N G L E   C O N T G A T E D
F-SWP : TYPE SOURCE MODE ▶
  
```

- ④ This completes setting the sweep mode to gated. Press the  key once to release the setting mode.

(2) Set sweep TYPE to FREQ

- ① Use the ◀ and ▶ keys to produce the following display (TYPE flashes).



- ② Press the  key, then use the ◀ and ▶ keys to produce the following display (FREQ flashes).







- ③ This completes setting the sweep type to frequency. Press the  key once to release the setting mode.

(3) Select the sweep FUNCTION

- ① Use the ◀ and ▶ keys to produce the following display (FUNCTION flashes).



- ② Press the  key.
- ③ Press the ▶ key, then select  with the  dial
- ④ After selecting, press the  key once to release the function select mode.

(4) Set the START frequency

- ① Use the ◀ and ▶ keys to produce the following display (START flashes).

1 0 0 0 . 0 0 0 0 0 0 0 0 H z F-SWP : ◀ FUNCTION START STOP ▶
--

- ② Press the ENTER key.
- ③ Set the frequency with the keypad or MODIFY dial.

For example, set to 100 Hz.

- ④ After setting, press the EXIT key once to release the start frequency setting mode.

(5) Set the STOP frequency

- ① Use the ◀ and ▶ keys to produce the following display (STOP flashes).



1 0 0 0 0 . 0 0 0 0 0 0 0 0 H z F-SWP : ◀ FUNCTION START STOP ▶
--

- ② Press the ENTER key.
- ③ Set the frequency with the keypad or MODIFY dial.



For example, set to 200 Hz.

- ④ After setting, press the EXIT key once to release the stop frequency setting mode.

(6) Set the sweep TIME

- ① Use the  and  keys to produce the following display (TIME flashes).





- ② Press the  key.
- ③ Set the sweep time with the keypad or  dial.



For example, set to 3 seconds.

- ④ After setting, press the  key once to release the sweep time setting mode.



(7) Set the STOP-LEVEL

- ① Use the  and  keys to produce the following display (STOP-LEVEL flashes).



- ② Press the  key.
- ③ Turn the  dial to produce the following display (ON flashes).





- ④ Press the  key, then set the stop level with the keypad or  dial. For example, set to 50 %.

The stop level is a percentage with respect to the maximum positive and negative amplitudes taken respectively as +100 % and -100 %.





- ⑤ After setting, press the  key to exit stop level setting.

(8) Start sweep

① Press the  key.

In this example, sweep ends after 3 seconds and oscillation stops. Again press the  key to sweep from the stop to the start frequency.

Other operations:



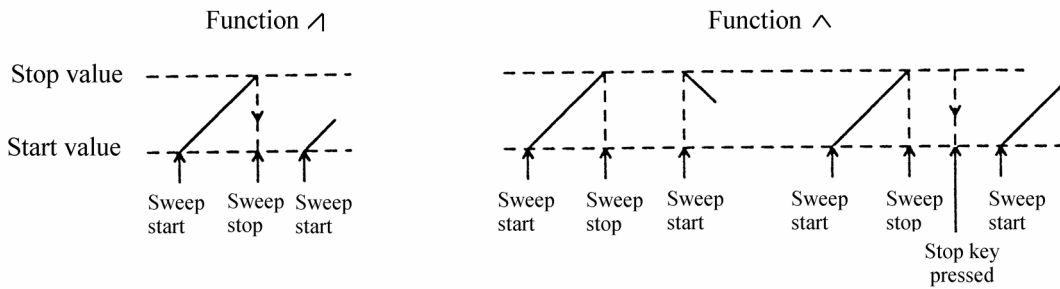

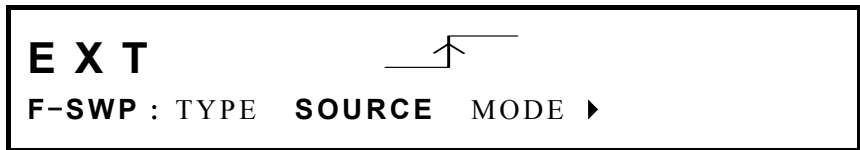

- **Sweep stop** : Press the  key. Oscillation stops. When sweep is stopped at gated sweep end or during sweep, press the  key to set the start value. (Oscillation stops)
- **Sweep pause** : Press the  key. To resume sweep, again press the  key.
- **Gated sweep operation examples**



- **External start** : Change the sweep trigger source to EXT and select rising or falling. Supply an external signal to the front panel TRIG/SWEEP IN connector. Observe that retrigger is not accepted for 100 ms after sweep start.



- **External pause** : Apply Low level to the rear panel SWEEP PAUSE IN connector. To resume sweep, apply a High level or open input.
- **FUNCTION** : The function determines the sweep type. For example,  provides step-type change of output (e.g., frequency) at the sweep time halfway point. LIN/LOG provides linear or logarithmic variation of the output with respect to the time axis.

-  — LIN
 — LOG
-  — LIN
 — LOG
- 
- SIN () — LIN
 — LOG

- **Internal trigger source**

- : Trigger signal of 50% duty is generated at the following trigger rate for sweep.
Even is set to less than 100 ms, the trigger is applied only at 100 ms intervals.
The trigger rate is common for CH1 and CH2.

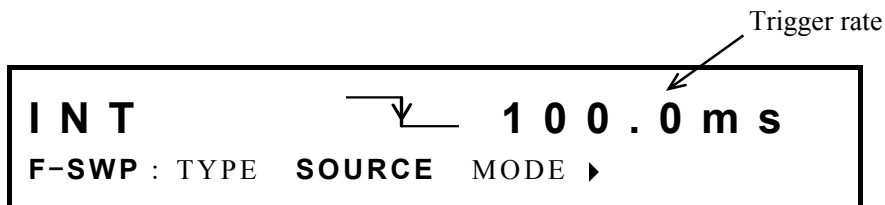

- **START-STATE and STOP-STATE** : Set output to start and stop values, respectively.

Both START-STATE and STOP-STATE oscillation can be conducted together with a gated sweep. Since sweep synchronization output becomes the respective start and stop states, full-scale adjustment of the recorder and the status of external equipment can be checked.

 "4.2 Sweep (■ Sweep value and marker/sync/X-DRIVE output)", cf.

- If the sweep type (TYPE) is set to DUTY, the output waveform automatically becomes a squarewave (variable duty). This makes it impossible to select the waveform (FUNCTION).
Multiple pulses may be output in one cycle during sweep, as shown below.



- If the frequency is low and the sweep rest period short, in some cases, oscillation may not stop immediately at the end of sweep.
- During sweep, if the oscillation mode of the other channel is changed, sweep stops.
- **To manually operate sweep (start, stop, pause, restart) for both channels simultaneously or to operate sweep via remote control (GPIB or USB), set both channels to sweep mode and set OPER-COMMON to on.**



■ CENTER, SPAN, MARKER, MKR → CTR

- **Center** is the sweep center value, while **span** is the range setting. The relationship among center, span, start and stop is as follows.

Values cannot be entered for CENTER and SPAN, however, if the sweep type is set from a user unit that has the log function.

- When start is changed:

Stop does not change.

$$\text{CENTER} = (\text{START} + \text{STOP}) \div 2$$

$$\text{SPAN} = |\text{START} - \text{STOP}|$$

- When stop is changed:

Start does not change.

$$\text{CENTER} = (\text{START} + \text{STOP}) \div 2$$

$$\text{SPAN} = |\text{START} - \text{STOP}|$$

- When center is changed:

Span does not change.

$$\text{START} = \text{CENTER} - /+ (\text{SPAN} \div 2)$$

$$\text{STOP} = \text{CENTER} +/- (\text{SPAN} \div 2)$$

- When span is changed:

Center does not change.

$$\text{START} = \text{CENTER} - /+ (\text{SPAN} \div 2)$$





$$\text{STOP} = \text{CENTER} +/- (\text{SPAN} \div 2)$$





- **MARKER** sets a value that changes the sweep marker output (SWEEP Z-MARKER OUT).
- **MKR → CTR** copies the marker value (**MARKER**) to the center value (**CENTER**).

■ Summary of the sweep setting items

- The following summarizes the items that need to be set during a sweep operation (in the SWEEP menu).





TYPE (sweep target) [FREQ, AMPTD, OFFSET, PHASE, DUTY]

SOURCE (trigger source) CH1: [EXT , EXT , INT  [s], INT  [s]]

CH2: [EXT CH2 , EXT CH2 , EXT CH1, INT  [s],
INT  [s]]

* Set when the sweep mode is SINGLE or GATED

MODE (sweep mode) [SINGLE, CONT, GATED]

FUNCTION (sweep waveform) [LIN , LOG , , LIN SIN, LOG SIN, LIN , LOG 

START (sweep start value)/STOP (sweep stop value)

or

CENTER (sweep center value)/SPAN (sweep width)

} Sweep range setting

TIME (sweep time) [s]

STOP-LEVEL (stop level)

PHASE (phase when oscillation starts) * ENTRY menu

} Set when the sweep mode is GATED

MARKER (Marker value)

MKR → CTR (Copy the marker value to the center value)

OPER-COMMON (simultaneous sweep operation of both channels) [OFF, ON]

- Sweep operations

- Main operation

START (sweep start)

STOP (sweep end/sweep start state)

*For subsequent operation when the sweep has been completed, the state is reset to the sweep start state.

PAUSE (sweep pause/restart)

- In the SWEEP menu

START-STATE (sweep start state)

STOP-STATE (sweep stop state)

■ Sweep (Modulation) steps and step width

Sweep and modulation outputs are changed by software. Methods for estimating sweep, modulation step number (number of output changes between start and stop values) and step width (variation width per change) are indicated below.

Sweep is described here. For modulation, replace sweep function with modulation waveform, sweep type with modulation type, and sweep time with modulation period, respectively.

The modulation period is determined as follows.

When the waveform is SIN, \wedge , \sqcap , \square , : Modulation period = $1 \div (\text{Modulation frequency} \times 2)$

When the waveform is \nearrow , \wedge : Modulation period = $1 \div \text{Modulation frequency}$

• **Step number derivation** (when oscillation mode of only one channel is sweep or modulation. Other times, see next page.)

(1) Sweep function is step (\sqcap):

Step number = Sweep time [s] \times 10000 (raise up, even number *1)

(2) Sweep function is other than step and sweep type is frequency:

① Sweep time is 25 ms and below:

Step number = Sweep time [s] \times 10000

② Sweep time is more than 25 to 31.25 ms and below:

Step number = 250 (fixed)

③ Sweep time is more than 31.25 ms:

Step number = Sweep time [s] \times 8000

(3) Sweep function is other than step and sweep type is other than frequency:

① Sweep time is 50 ms and below:

Step number = Sweep time [s] \times 10000

② Sweep time is more than 50 to 62.5 ms and below:

Step number = 250 (fixed)

③ Sweep time is more than 62.5 ms:

Step number = Sweep time [s] \times 8000

*1: If raising up results in odd number, -1.

- **Step number derivation** (when oscillation mode of both channels is sweep or modulation. Other times, see previous page.)

First, determine the reference and secondary channels. The reference channel is that with the shorter sweep time or modulation period and is defined by the following method. The reverse is used for the secondary channel. The modulation period is determined by the following formulae.

When the modulation waveform is SIN, \wedge or \sqcap ,
the modulation period = $1 \div (\text{modulation frequency} \times 2)$

When the modulation waveform is \swarrow or \searrow ,
the modulation period = $1 \div (\text{modulation frequency})$

a. Reference channel step number

(1) Sweep type is frequency

- ① Sweep time: 25 ms and less

Step no. = sweep time (s) \times 5000 (round down, even number if more than 1.6 ms *2)

- ② Sweep time: more than 25 ms, but 31.25 ms and less

Step no. = 124 (fixed)

- ③ Sweep time: more than 31.25 ms

Step no. = sweep time (s) \times 4000

(2) Sweep type other than frequency

- ① Sweep time: 50 ms and less

Step no. = sweep time (s) \times 5000 (round down, even number if more than 1.6 ms *2)

- ② Sweep time: more than 50 ms, but 62.5 ms and less

Step no. = 250 (fixed)

- ③ Sweep time: more than 62.5 ms

Step no. = sweep time (s) \times 4000

(3) Sweep type modulation

- ① Modulation period: 25 ms and less

Step no. = sweep time (s) \times 5000

(rounded off, if modulation waveform is \swarrow or \searrow , even number *2, also integer multiple of 4.
If other modulation waveform, even number if more than 1.6 *2.)

- ② Modulation period: more than 25 ms, but 31.25 ms and less

Step no. = 124 (fixed)

- ③ Modulation period: more than 31.25 ms

Step no. = sweep time (s) \times 4000

(rounded off, if modulation waveform is step, even number)

*2: If rounded up/off results are odd, -1.

(4) Modulation type other than frequency

- ① Modulation period: 50 ms and less

Step no. = sweep time (s) × 5000

(rounded off, if modulation waveform is \sphericalangle or \sphericalright , even number *2, also integer multiple of 4 if more than 3.2 ms. If other modulation waveform, even number if more than 1.6 ms *2)

- ② Modulation period: more than 50 ms, but 62.5 ms and less

Step no. = 250 (fixed)

(248 if the modulated waveform is \sphericalangle or \sphericalright)

- ③ Modulation period: more than 62.5 ms

Step no. = modulation period (s) × 4000

(rounded off, if modulation waveform is step, even number)

(5) Exceptions

- ① If the sweep type is changed after setting the sweep time, the step number remains the same. For example, if the sweep type is changed from frequency to amplitude, the step number remains as in item (1).
- ② If the modulation type is set for frequency, then the modulation waveform is changed, the step number remains the same. For example, if changed from frequency to amplitude modulation, the step number remains as in item (3).

b. Secondary channel step number

Step no. = reference channel step no. × secondary channel sweep time (modulation period) ÷ reference channel sweep time (modulation period)

(If function is step, round up to even number *2, if other function, round off.)

*2: If rounded up/off results are odd, -1.

• Deriving step widthDuring linear sweep, step width = $\frac{\text{Span}}{\text{Step number} - 1}$ During logarithmic sweep, step width = $\log_{10}^{-1} [\log_{10} \frac{\text{stop}}{\text{start}} \div (\text{step no.} - 1)]$

Step width during log sweep changes with step progression.

Marker output is synchronized with the sweep step. The shift between the marker value setting and the actual value that changes marker output is equal to the \pm step width.

■ Sweep value and marker/sync/X-DRIVE output
 (SWEEP Z-MARKER OUT / SYNC OUT / SWEEP X-DRIVE OUT)

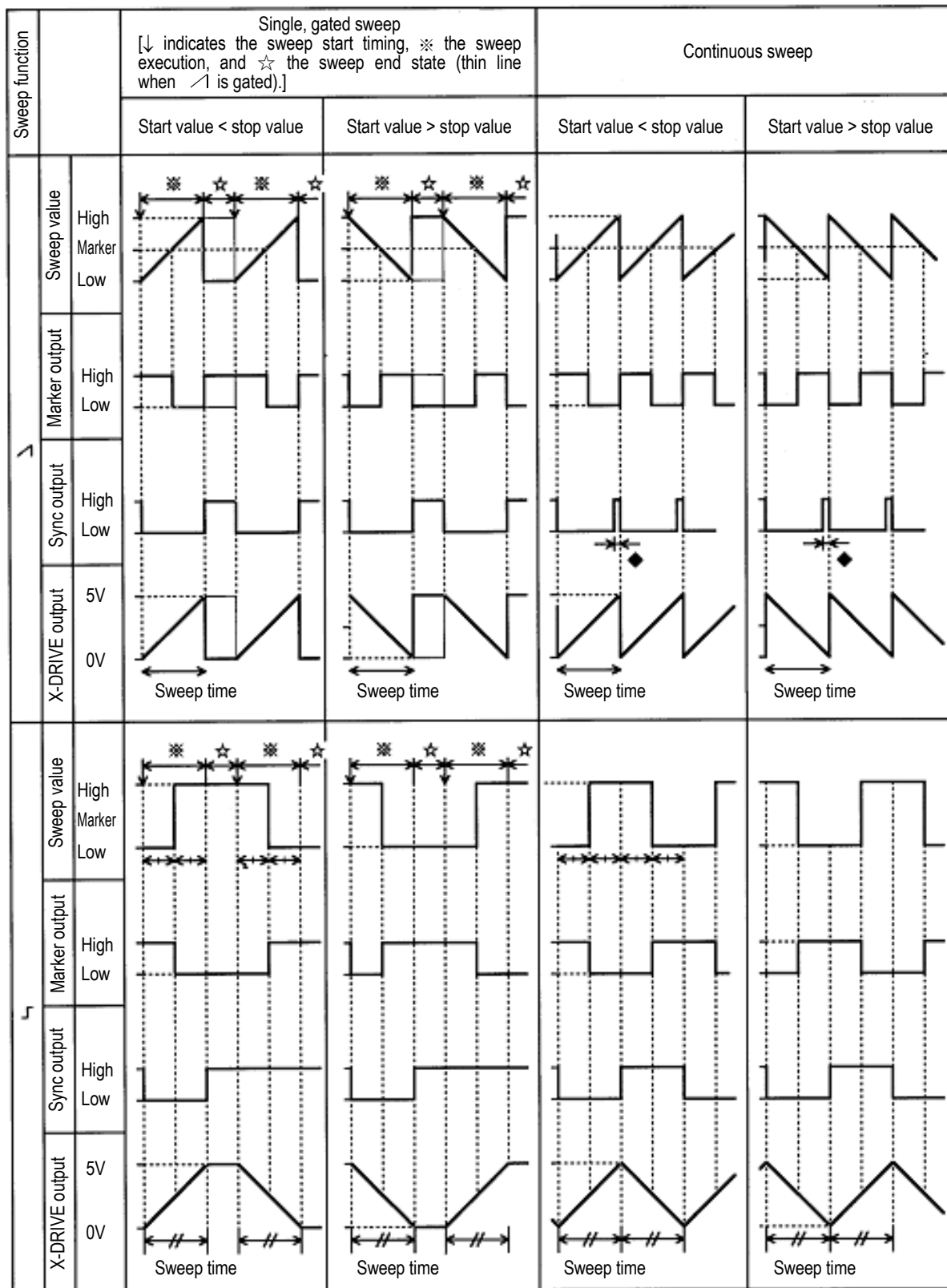

◆ Approximately 200 to 250 μs when the oscillation mode of both CH1 and CH2 is sweep or modulation, approx. 100 to 125 μs at other times.

4.2 Sweep

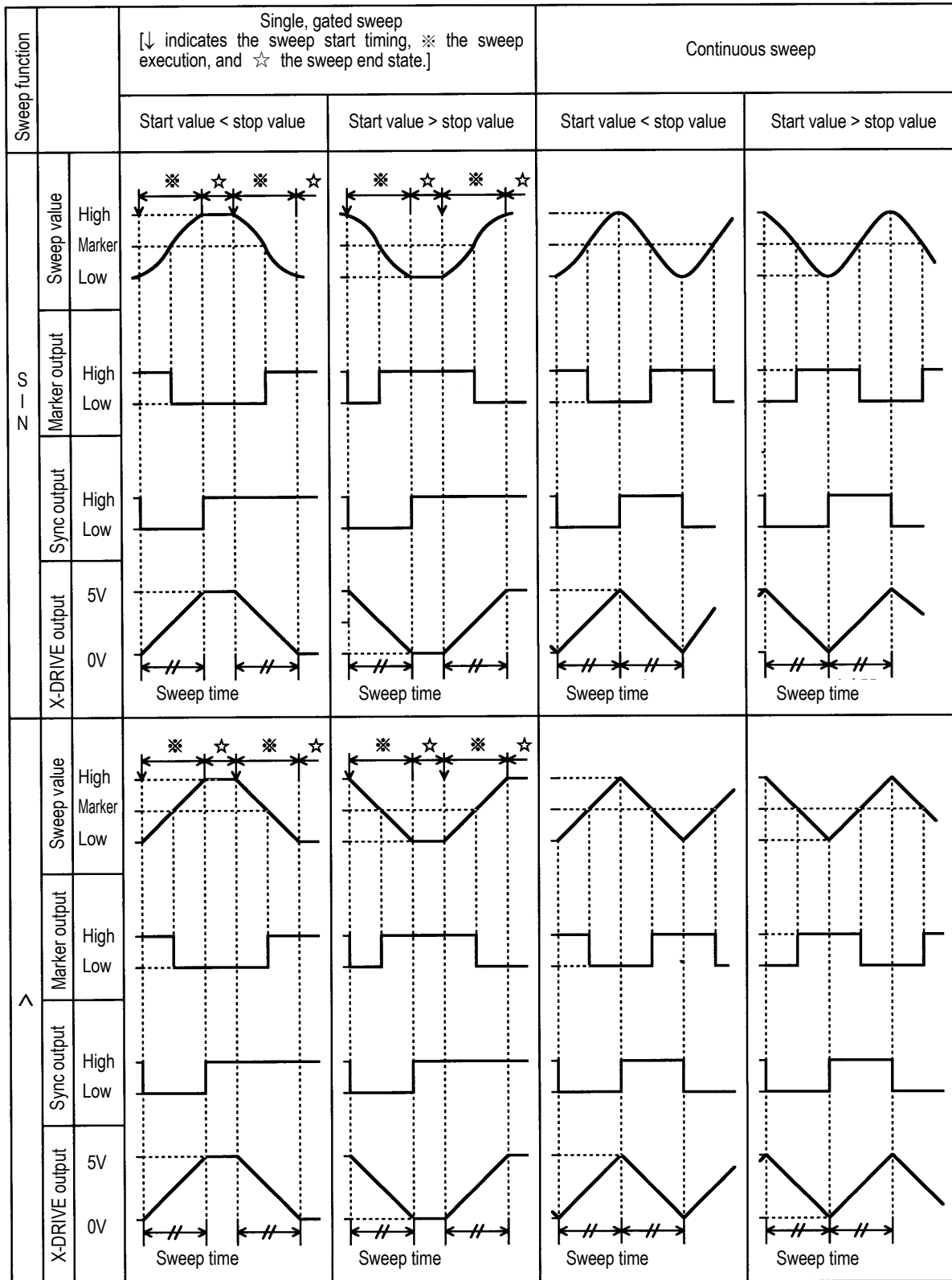

4.3 Modulation

■ Frequency modulation (FM) (→ → TYPE : FM)

Operation to produce a frequency modulated waveform output is described.



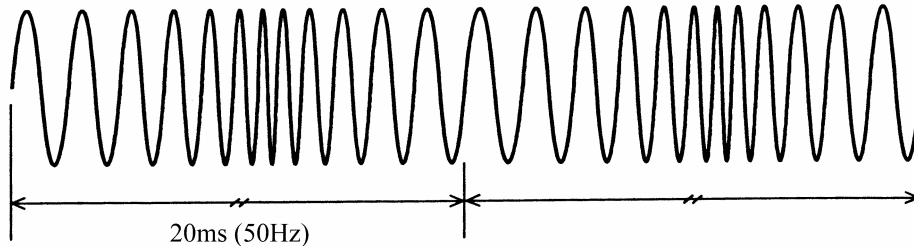

The example is a sinewave, 1 kHz, amplitude and DC offset arbitrary.



Frequency is 1 kHz varying ± 250 Hz
Deviation period is 20 ms (50 Hz)



Operation:

(1) Set modulation TYPE to frequency (FM)

- ① Press the  key, then the  key.
- ② Use the  and  keys to produce the following display (TYPE flashes).

```

F M  A M  O F S M  P M  P W M
FM : TYPE  DEVIATION  FREQ  FUNCTION
    
```

- ③ Press the  key, then use the  and  keys to produce the following display (FM flashes).

```



F M  A M  O F S M  P M  P W M
FM : TYPE  DEVIATION  FREQ  FUNCTION
    
```

- ④ This sets the modulation type for frequency. Press the  key once to release the type setting mode.

(2) Set the frequency DEVIATION

- ① Use the ◀ and ▶ keys to produce the following display (DEVIATION flashes).





- ② Press the  key.
- ③ Set the deviation with the keypad or  dial.
For example, set to 500 Hz.
- ④ After setting, press the  key once to exit frequency deviation setting.

(3) Set the modulation FREQ

- ① Use the ◀ and ▶ keys to produce the following display (FREQ flashes).





- ② Press the  key.
- ③ Set the frequency with the keypad or  dial.
For example, set to 50 Hz (20 ms).
- ④ After setting, press the  key once to release the modulation setting mode.

(4) Select the modulation waveform (FUNCTION)

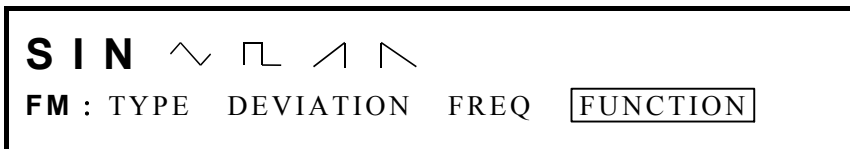
- ① Use the ◀ and ▶ keys to produce the following display (FUNCTION flashes).



- ② Press the  key, then use the  and  keys to produce the following display (SIN flashes).



- ③ After making a selection, press the  key to exit function setting.

The above completes frequency modulation setting.

Other operations:

- When the oscillation mode is changed to modulation (MODU), modulation occurs at the setting at that time point.

To stop modulation: Press the  key. Resume modulation by pressing the  key.

- During modulation, if the oscillation mode of the other channel is changed, modulation stops.
- **To start or stop modulation of both channels simultaneously on a manual operation or via remote control (GPIB or USB),** set both channels to modulation mode and set OPER-COMMON to on.

If the BOTH lamp is on, behavior is the same even though OPER-COMMON is off.







- Setting items at frequency modulation (MODU menu)

TYPE: FM

DEVIATION (frequency deviation) [Hz]

FREQ (modulation frequency) [Hz]

FUNCTION (modulation waveform) [SIN, , , , ]

OPER-COMMON (operation in both channels) [OFF, ON]

■ **Amplitude modulation (AM)** ($\overset{\text{MODE}}{\text{O}}$ → $\overset{\text{MODU}}{\text{O}}$ → **TYPE : AM**)

Operation to produce an amplitude modulated waveform output is described below.

In the example, the waveform is a sine wave, the frequency is 1800 Hz, the amplitude is 1.5 V_{p-p}, and the DC offset is set to 0 V.

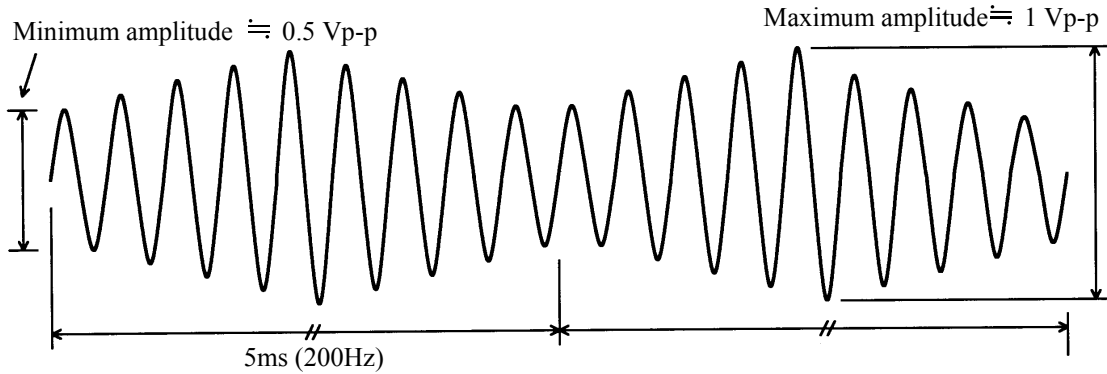

Operation:

(1) Set modulation TYPE to amplitude modulation (AM)

- ① Press the $\overset{\text{MODE}}{\text{O}}$ key, then the $\overset{\text{MODU}}{\text{O}}$ key.
- ② Use the \langle and \rangle keys to produce the following display (TYPE flashes).



- ③ Press the $\overset{\text{ENTER}}{\text{O}}$ key, then use the \langle and \rangle keys to produce the following display (AM flashes).





- ④ This sets the modulation type for amplitude. Press the $\overset{\text{EXIT}}{\text{O}}$ key once to release the type selection mode.

(2) Set the modulation DEPTH (width of amplitude variance)

- ① Use the ◀ and ▶ keys to produce the following display (DEPTH flashes).



				50.0	%
AM :	TYPE	DEPTH	FREQ	FUNCTION	

- ② Press the  key.
- ③ Use the keypad or turn the  dial to set the modulation factor.
For example, set to 33%.
- ④ After setting, press the  key once to release the modulation depth setting mode.

(3) Set the modulated frequency (frequency at which the amplitude changes, FREQ)

- ① Use the ◀ and ▶ keys to produce the following display (FREQ flashes).



				100.00	Hz
AM :	TYPE	DEPTH	FREQ	FUNCTION	

- ② Press the  key.
- ③ Use the keypad or turn the  dial to set the modulated frequency.
For example, set the modulated frequency to 200 Hz (5 ms).
- ④ After setting, press the  key once to release the modulated frequency setting mode.

(4) Select the modulated waveform (FUNCTION)

- ① Use the ◀ and ▶ keys to produce the following display (FUNCTION flashes).

SIN				
AM :	TYPE	DEPTH	FREQ	FUNCTION



- ② Press the  key, then use the  and  keys to produce the following display (SIN flashes).







- ③ When selection is complete, press the  key to release the setting mode.

The above completes setting of the amplitude modulation.

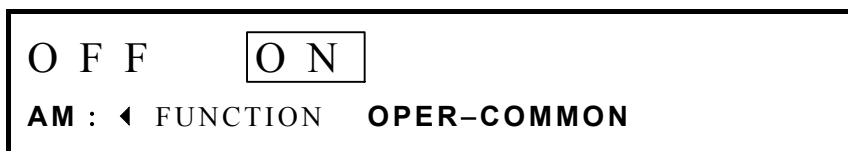
Other operations:

- When the oscillation mode is changed to modulation (MODU), modulation occurs at the setting at that time point.
- **To stop modulation :** Press the  key. Resume modulation by pressing the  key.
- **Amplitude setting vs. maximum or minimum amplitudes**
 - : Max. amplitude = Amplitude setting ÷ 2 [1 + (depth % ÷ 100)]
 - Min. amplitude = Amplitude setting ÷ 2 [1 - (depth % ÷ 100)]
- At 0 % depth, the output amplitude is 1/2 the setting. At 100 % depth, the output amplitude is the same as the setting.
- During modulation, if the oscillation mode of the other channel is changed, modulation stops.
- **To start or stop a modulation operation on both channels simultaneously by manual operation or via remote control (GPIB or USB),** set both channels to modulation mode and set OPER-COMMON to on.



- Setting items at frequency modulation (MODU menu)
 - TYPE: AM
 - DEPTH (modulation depth) [%]
 - FREQ (modulation frequency) [Hz]
 - FUNCTION (modulation waveform) [SIN, , , , ]
 - OPER-COMMON (operation in both channels) [OFF, ON]

■ DC offset modulation (OFSM) ($\text{MODE} \rightarrow \text{MODU} \rightarrow \text{TYPE : OFSM}$)

Operation to produce a DC offset modulated waveform output is described below. The example refers to a sinewave, 2 kHz, amplitude 1 Vp-p and DC offset 0 V.

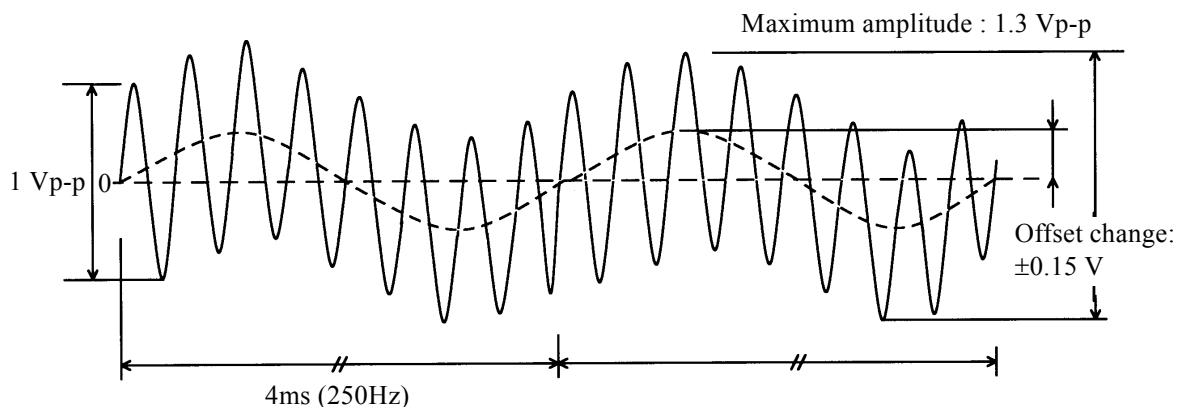

Operation:

(1) Set modulation TYPE to DC offset (OFSM)

- ① Press the MODE key, then the MODU key.
- ② Use the LEFT and RIGHT keys to produce the following display (TYPE flashes).

```

F M  A M  O F S M  P M  P W M
FM : TYPE  DEVIATION  FREQ  FUNCTION
  
```



- ③ Press the ENTER key, then use the LEFT and RIGHT keys to produce the following display (OFSM flashes).

```



F M  A M  O F S M  P M  P W M
OFSM : TYPE  DEVIATION  FREQ  $\blacktriangleright$ 
  
```

- ④ This sets the modulation type for DC offset. Press the EXIT key once to release the type selection mode.

(2) Set the DC offset DEVIATION

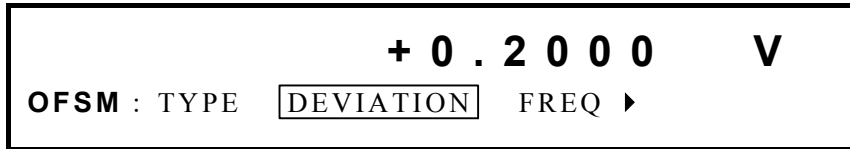
- ① Use the  and  keys to produce the following display (DEVIATION flashes).





- ② Press the  key.
- ③ Set the deviation with the keypad or  dial.



For example, set to 0.3 V.

- ④ After setting, press the  key once to exit DC offset deviation setting.

(3) Set the modulated FREQ

- ① Use the  and  keys to produce the following display (FREQ flashes).





- ② Press the  key.
- ③ Set the frequency with the keypad or  dial.



For example, set to 250 Hz (4 ms).

- ④ After setting, press the  key once to release the modulated frequency setting mode.

(4) Select the modulated waveform (FUNCTION)

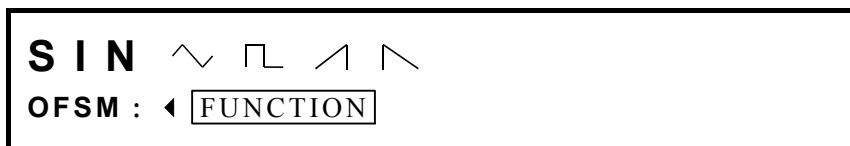
- ① Use the  and  keys to produce the following display (FUNCTION flashes).



- ② Press the  key, then use the  and  keys to produce the following display (SIN flashes).

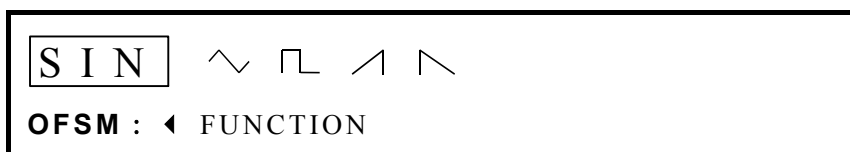

- ③ After selecting, press the  key to release the setting mode.

The above completes DC offset modulation setting.



Other operations:

- **Amplitude setting vs. maximum amplitudes**

: Max. amplitude = Amplitude setting [Vpeak] + DC offset deviation

- When the oscillation mode is changed to modulation (MODU), modulation occurs at the setting at that time point.

- **To stop modulation**

: Press the  key. Resume modulation by pressing the  key.

- During modulation, if the oscillation mode of the other channel is changed, modulation stops.

- **To start or stop a modulation operation on both channels simultaneously by manual operation or via remote control (GPIB or USB), set both channels to modulation mode and set OPER-COMMON to on.**







- Setting items in DC offset modulation (MODU menu)

TYPE: OFSM

DEVIATION (DC offset deviation) [V]

RREQ (modulation frequency) [Hz]

FUNCTION (modulation waveform) [SIN, , , , 

OPER-COMMON (operation in both channels) [OFF, ON]

■ **Phase modulation (PM)** (→ → **TYPE : PM**)

Operation to produce a phase modulated waveform output is described below. In this example, the waveform is triangular, the 1 kHz, DC offset is set to 0 V, the oscillation start phase is set to 0 degrees, and the frequency and amplitude are set to arbitrarily defined values.

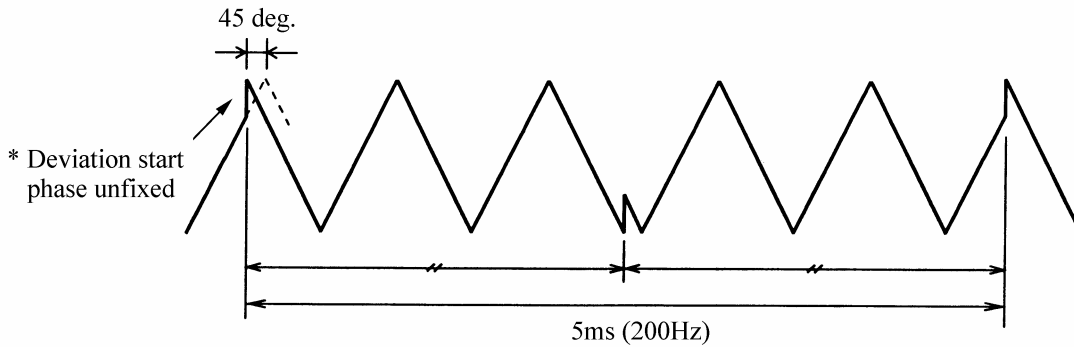

Operation:

(1) Set modulation TYPE to phase (PM)

- ① Press the key, then the key.
- ② Use the and keys to produce the following display (TYPE flashes).

```

F M A M O F S M P M P W M
FM : TYPE DEVIATION  FREQ  FUNCTION
    
```



- ③ Press the key, then use the and keys to produce the following display (PM flashes).

```



F M A M O F S M P M P W M
PM : TYPE DEVIATION  FREQ  FUNCTION
    
```

- ④ This sets the modulation type for phase. Press the key once to release the type setting mode.

(2) Set the phase DEVIATION

- ① Use the  and  keys to produce the following display (DEVIATION flashes).





- ② Press the  key.
- ③ Set the deviation with the keypad or  dial.



For example, set to 45 degrees.

- ④ After setting, press the  key once to release the deviation setting mode.

(3) Set the modulation FREQ (frequency with varying phase)

- ① Use the  and  keys to produce the following display (FREQ flashes).





- ② Press the  key.
- ③ Set the frequency with the keypad or  dial.





For example, set to 200 Hz (5 ms).

- ④ After setting, press the  key once to release the modulation frequency setting mode.

(4) Select the modulation waveform (FUNCTION)

- ① Use the  and  keys to produce the following display (FUNCTION flashes).





- ② Press the  key, then use the  and  keys to produce the following display ( flashes).







- ③ After selecting, press the  key to release the function setting mode.

The above completes phase modulation setting.

Other operations:

- When the oscillation mode is changed to modulation (MODU), modulation occurs at the setting at that time point.
To stop modulation : Press the  key. Resume modulation by pressing the  key.
- During modulation, if the oscillation mode of the other channel is changed, modulation stops.
- **To start or stop modulation of both channels simultaneously on a manual operation or via remote control (GPIB or USB),** set both channels to sweep mode and set OPER-COMMON to on.



- Setting items at phase modulation (MODU menu)
 TYPE: PM
 DEVIATION (phase deviation) [Hz]
 FREQ (modulation frequency) [Hz]
 FUNCTION (modulation waveform) [SIN, , , , ]
 OPER-COMMON (operation in both channels) [OFF, ON]

■ Pulse width modulation (PWM) (MODE → MODU → TYPE : PWM)

Operation to produce a pulse width modulated waveform output is described below. The example is a squarewave (duty variable), duty 50 %, frequency 800 Hz, amplitude and DC offset arbitrary.

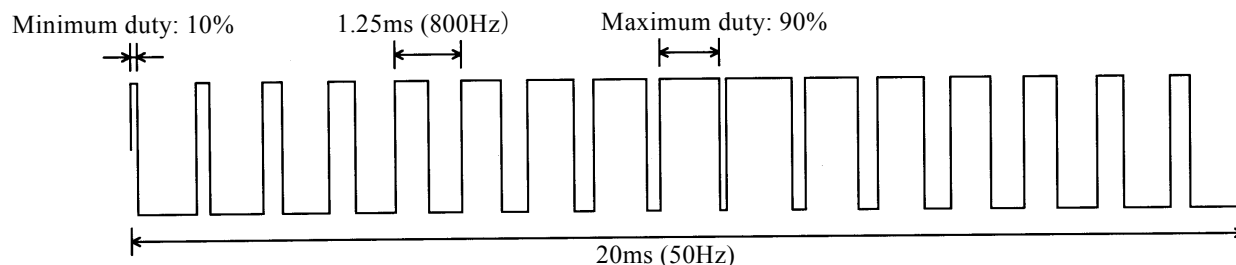

Operation:

(1) Set modulation TYPE to pulse width (PWM)

- ① Press the MODE key, then the MODU key.
- ② Use the ◀ and ▶ keys to produce the following display (TYPE flashes).

```

F M  A M  O F S M  P M  P W M
FM : TYPE  DEVIATION  FREQ  FUNCTION
  
```

- ③ Press the ENTER key, then use the ◀ and ▶ keys to produce the following display (PWM flashes).

```

F M  A M  O F S M  P M  P W M
PWM : TYPE  DEVIATION  FREQ  FUNCTION
  
```

- ④ This sets the modulation type for pulse width. Press the EXIT key once to release the type setting mode.

The waveform is automatically set to squarewave (variable duty) during PWM. The waveform (FUNCTION) cannot be selected.

(2) Set the pulse width DEVIATION

- ① Use the ◀ and ▶ keys to produce the following display (DEVIATION flashes).

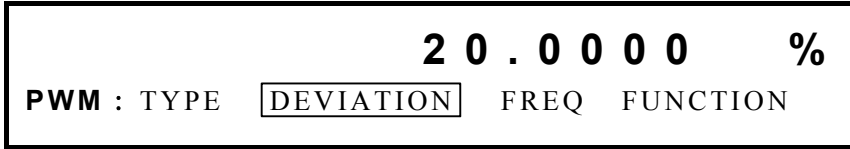

- ② Press the  key.

Set the deviation with the keypad or  dial. For example, set to 80 %.

- ③ After setting, press the  key once to exit pulse width deviation setting.

(3) Set the modulation FREQ (frequency with varying pulse-width)

- ① Use the ◀ and ▶ keys to produce the following display (FREQ flashes).

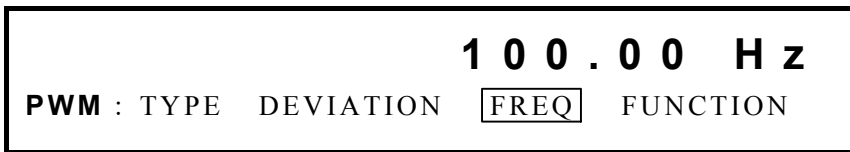

- ② Press the  key.

Set the frequency with the keypad or  dial.



For example, set to 50 Hz (20 ms).

- ③ After setting, press the  key once to release the modulation frequency setting mode.

(4) Select the modulated waveform (FUNCTION)

- ① Use the ◀ and ▶ keys to produce the following display (FUNCTION flashes).





- ② Press the  key, then use the  and  keys to produce the following display (SIN flashes).



- ③ After selecting, press the  key to release the setting mode.

The above completes pulse width modulation setting.



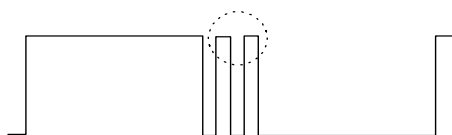

Other operations:

- When the oscillation mode is changed to modulation (MODU), modulation occurs at the setting at that time point.
- **To stop modulation :** Press the  key. Resume modulation by pressing the  key.
- **Duty setting vs. maximum or minimum duties**
 - : Max. duty = Duty setting + (pulse width deviation% ÷ 2)
 - Min. duty = Duty setting – (pulse width deviation% ÷ 2)
- During modulation, multiple pulses may be output in one cycle, as shown below.



- During modulation, if the oscillation mode of the other channel is changed, modulation stops.
- **To start or stop modulation of both channels simultaneously on a manual operation or via remote control (GPIB or USB),** set both channels to modulation mode and set OPER-COMMON to on.



- Setting items at pulse width modulation (MODU menu)
 - TYPE: PWM
 - DEVIATION (pulse width deviation) [%]
 - FREQ (modulation frequency) [Hz]
 - FUNCTION (modulation waveform) [SIN, , , , ]
 - OPER-COMMON (operation in both channels) [OFF, ON]

4.4 Arbitrary Waveform

■ Arbitrary waveform (ARB) ($\text{FUNCTION} \rightarrow \text{ARB}$)

Operation using arbitrary waveform (ARB) to produce a sinewave with clipped peak output is described.

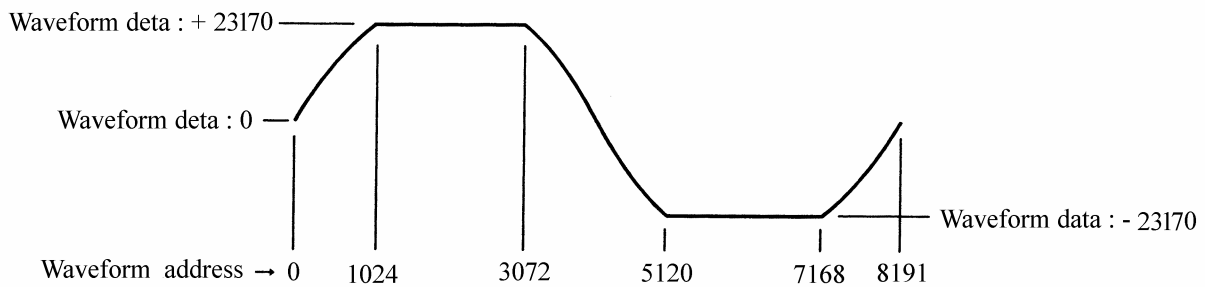

Operation:

(1) Set waveform to arbitrary (ARB)

- ① Press the FUNCTION key, then the ARB key.

(2) Select an arbitrary waveform to be edited/output (SELECT).

- ① Press the ARB EDIT key, then use the \leftarrow and \rightarrow keys to produce the following display (SELECT flashes).

```

0 : A R B _ 0 0   1 : A R B _ 0 1   ▶
ARB : SELECT   NAME EDIT COPY ▶
    
```

- ② Press the ENTRY key, then use the \leftarrow and \rightarrow keys to produce the following display (1:ARB_01 flashes).

```

0 : A R B _ 0 0   1 : A R B _ 0 1   ▶
ARB : SELECT   NAME EDIT COPY ▶
    
```

- ③ This completes the selection of an arbitrary waveform (No. 1 is selected here). Press the EXIT key one time to release the arbitrary waveform selection mode.

(3) Copy the waveform, for example, sinewave

- ① Press the ^{ARB EDIT} key, then use the ◀ and ▶ keys to produce the following display (COPY flashes).



- ② Press the ^{ENTER} key, then use the ◀ and ▶ keys to produce the following display (SIN flashes).



- ③ Press the ^{ENTER} key to copy the sinewave.

(4) Edit the waveform, for example, peak clip

- ① Use the ◀ and ▶ keys to produce the following display (EDIT flashes).

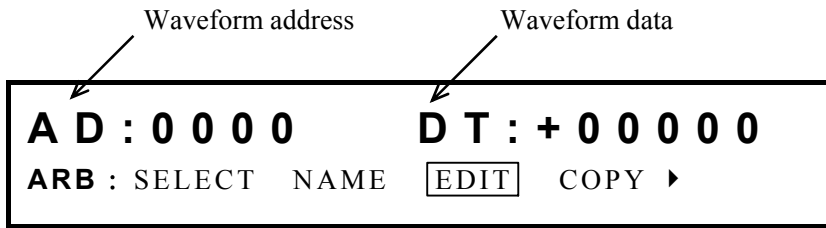

- ② Press key, then the ◀ key (AD digit flashes).



- ③ Set the waveform address (AD) with the keypad or ^{MODIFY} dial.





For example, set to 1024.

- ④ Press the key to produce the following display (the asterisk (*) is displayed).



* is interpolation type mark and indicates the linear interpolation type address. The mark appears and extinguishes each time the key is pressed.

- ⑤ Next, use above steps ③ and ④ to set the interpolation mark (*) to waveform address 3072.

- ⑥ Press the  key for linear interpolation. In this example, the first half of the sinewave is clipped (). The waveform data (DT) change as a result of linear interpolation between the starred addresses.
- ⑦ Press the  key, then use the  and  keys to produce the following display (MARK-CLEAR flashes).

```

1 : A R B _ 0 1
ARB : ◀ MARK-CLEAR CLEAR SIZE





```

Press the  key twice to clear the interpolation marks from addresses 1024 and 3072.



- ⑧ In the same manner as above steps ① to ⑥, clip the first half of a sinewave (set interpolation marks at 5120 and 7168).





The above completes arbitrary waveform setting.

Other operations:





- **Arbitrary waveform data input:**  → EDIT select →  →  flashes the waveform data (DT) digits. Use the keypad or  dial to set the data.

Data upper and lower limits are +32767 and -32768, which correspond to the amplitude peak-to-peak settings. For this reason, when the waveform vertical limits are changed by the above type of method, the amplitude setting (Vp-p) and the actual output waveform Vp-p do not coincide. The data set addresses are automatically the linear interpolation addresses (the * mark is displayed).

- **Clear (to 0) waveform data:**  → CLEAR select → , then again press . The interpolation marks (*) are also cleared.



- **Apply a name to an arbitrary waveform:**  → NAME select → , then use the  dial to select the characters. Shift position with  and , and input. Up to 8 characters can be input. Following are the usable characters.

abcdefghijklmnopqrstuvwxyz ▾ (space)
 ABCDEFGHIJKLMNOPQRSTUVWXYZ0123456789
 !"#\$%&'()*+,-./:;<=>?@[\\]^_`{|} → ←

- **Change the waveform data size:**  → SIZE select →  → Use  and  to select the data size

Relation between the waveform data size and number of waveforms

Data size	Waveform number												Number of waveforms
	0	1	2	3	4	5	6	7	8	9	10	11	
8k(8192)	0	1	2	3	4	5	6	7	8	9	10	11	12
16k(16384)	0		1		2		3		4		5		6
32k(32768)	0				1				2				3



The output waveform changes as described below when the waveform data size is changed. If, for example, the waveform data size is changed from 16 KB to 8 KB when there is a waveform like  for waveform number 0,  is assigned to waveform number 0 and  to waveform number 1.

- Arbitrary waveform data are common for CH1 and CH2.

4.5 Selecting waveforms of synchronous signals (SYNC OUT)





This section describes the switching of SYNC OUT waveforms.

■ Procedure

- ① Press the  key, then use the  and  keys to produce the following display
(The lower SYNC OUT flashes).

```

STATE : P H A S E
SYSTEM : ◀ DUTY-VALID SYNCOUT ▶
    
```

- ② Press the  key, then use the  and  keys to set the SYNC OUT waveform.
- ③ After setting, press the  key to release the SYNC OUT waveform setting mode.

■ When the oscillation mode is BURST

- STATE: Low level during oscillation. High level while stopped.
- PHASE: For  squarewaves (variable duty), the same waveform as that for FUNCTION OUT.
For other cases, high level while between 0 and 180 degrees of the waveform in the oscillation period, and low level while between 180 and 360 degrees.

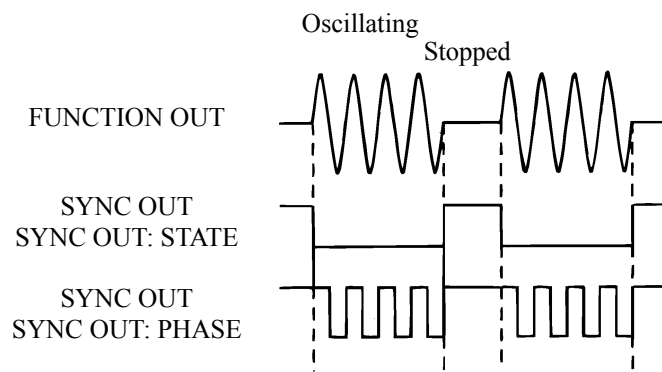

■ **When the oscillation mode is SWEEP**

- STATE: Low level while sweeping from the start value to the stop value. Otherwise, high level.
- PHASE: For \square squarewaves (variable duty), the same waveform as that for FUNCTION OUT. Otherwise, high level while between 0 and 180 degrees of the waveform, and low level while between 180 and 360 degrees.

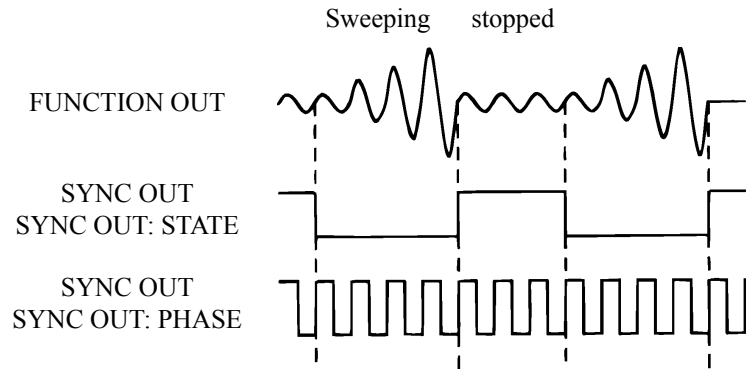

■ **When the oscillation mode is MODU**

- STATE: High level while modulation is stopped, or the modulation wave is from 0 up to but not including 180 degrees. Low level while the modulation wave is from 180 up to but not including 360 degrees.
- PHASE: For \square squarewaves (variable duty), the same waveform as that for FUNCTION OUT. Otherwise, high level while between 0 and 180 degrees of the modulated waves, and low level while between 180 and 360 degrees.

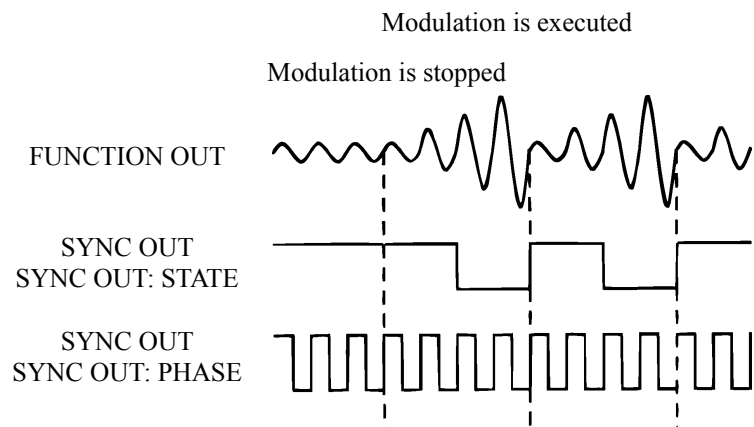

■ Additional information:

- For \sim and \square (fixed duty) at frequencies over 100 kHz, if SYNC OUT is set to PHASE, the output signal becomes a waveform with the analog signals of a sinewave applied to the comparator. For this reason, the output level (high or low) may be undefined at 0, 180, and 360 degrees (± 2 degrees, approximately).

In particular, note that when the oscillation mode is switched during a burst or gated sweep while oscillation is stopped, the output level may vary or the waveform may become glitch-shaped.

If a precise output level is required while oscillation is stopped, shift the phase setting. For example, setting the phase at + 90 degrees shifts the output level to the high level while oscillation is stopped.

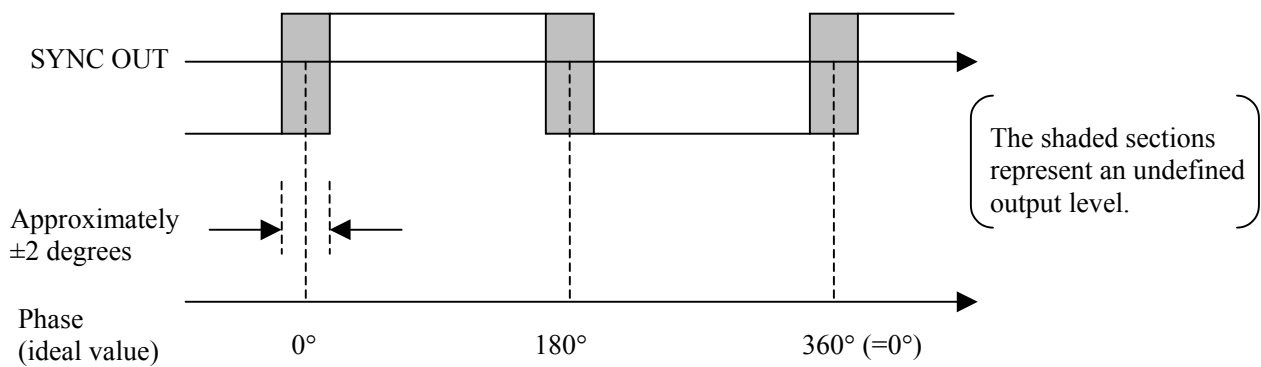

4.6 Output waveforms for sweeping and modulation

The setup values for sweeping and modulation are updated every 100 to 252 μs . Thus, if the sweep time is short or the modulation frequency is high, the amount of change for updating increases, leading to marked discontinuities.

If the sweep function (modulated waves) is \square , \triangle , or ∇ , discontinuities become conspicuous in some of the stepwise variations.

Since the setup values vary enormously in some of the stepwise variations, discontinuities are generated. If such discontinuities are removed, the remaining variations have the appearance shown below.

If, as an extreme example, the oscillation frequency is 1 kHz, the sweep time is 4 ms, the start phase is 180 degrees, the stop phase is -180 degrees, and the sweep function is \triangle in the phase sweep, the phase shifts about 26 degrees every 100 μs , producing the following output waveforms. Discontinuities are generated not only by \sim , but also by \sphericalangle , \triangle , and ∇ .

Since the phase changes at intervals of 100 to 252 μs , discontinuities are generated

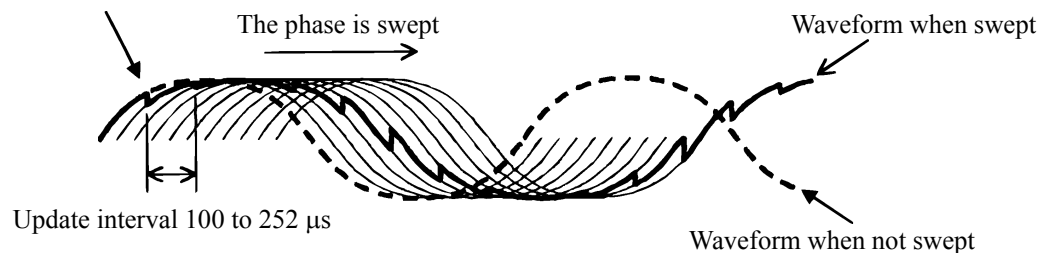

Since the \square squarewaves (fixed duty) and \square squarewaves (variable duty) are generated differently from other waveforms, extra pulses are produced.

Similarly, extra pulses are also produced by phase modulation, duty sweep, and PWM.

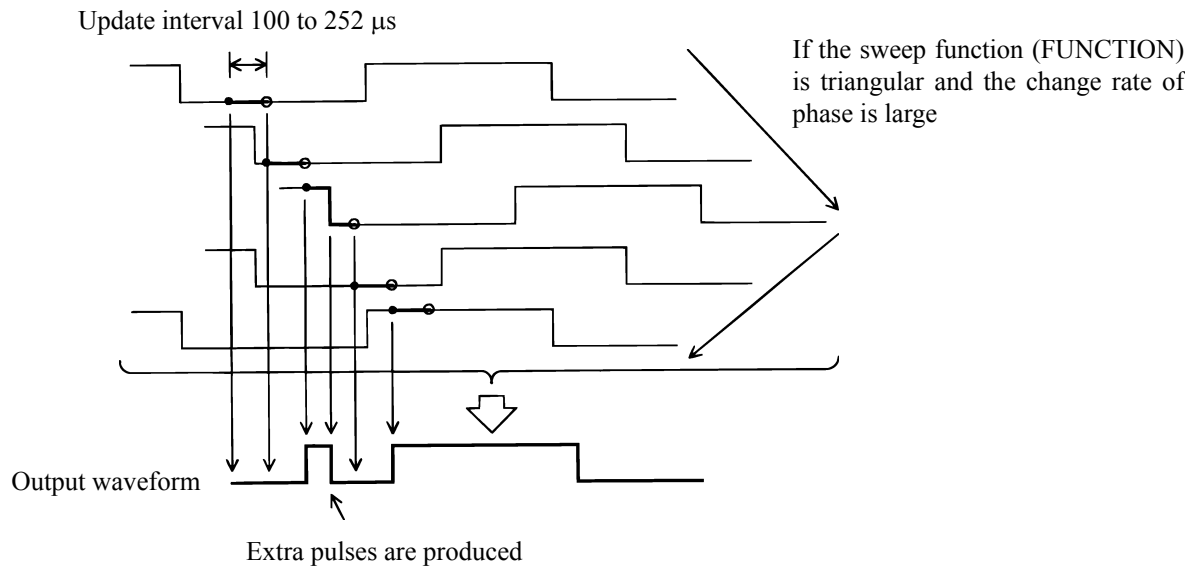

The occurrence frequency when the sweep function is \sim , \sphericalangle , or ∇ is roughly given by the following formula:

$$\text{Occurrence frequency [\%]} = \frac{\text{phase span [deg]}}{360 \times \text{oscillation frequency [Hz]} \times \text{sweep time [s]}} \times 100$$

If, for example, the frequency is 1 kHz, the phase span is 90 degrees, and the sweep time is 100 ms, an extra pulse is generated every 400 cycles on average.

4.7 Equivalent noise bandwidth

The density of noise generated by the WF1966 is as shown in the following figure (a) "Frequency characteristics of noise generated by the WF1966."

The effective values (rms) of (a) are equal to those of white noise in the figure (b) "Frequency characteristics of white noise," that follows. This equivalent bandwidth (2 MHz) is called the equivalent noise bandwidth.

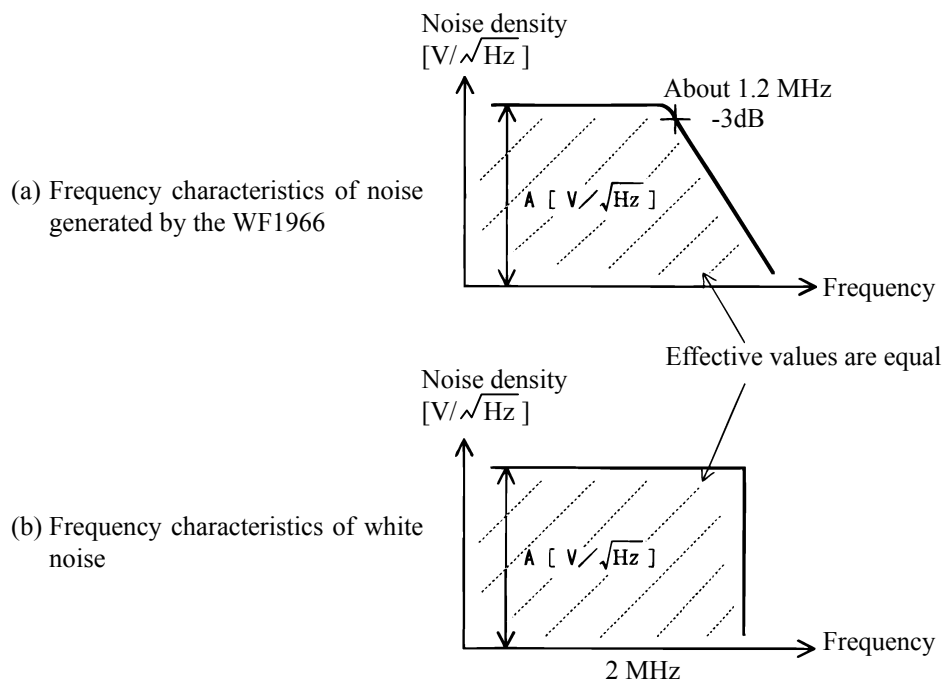

The noise density shows flat frequency characteristics up to about 1.2 MHz. If the band of noise is too wide or extra signal elements outside the band cause a problem, connect, for example, a low-pass filter for output. Note, however, that the amplitude becomes smaller as band restrictions increase.

Section 5 Other Operations

5.1	Convenient Settings	5-2
	■ Frequency [Hz] setting by period [s]	5-2
	■ Squarewave duty setting	5-3
	■ Squarewave pulse width setting	5-6
	■ Amplitude and DC offset setting by high and low level	5-7
5.2	Units	5-9
	■ Engineering unit (μ , m, k, M) display	5-9
	■ Amplitude units change	5-10
	■ User-unit setting	5-11
5.3	Setting memory	5-15
	■ Setting store	5-15
	■ Setting recall	5-16
	■ Setting memory clear	5-17
5.4	External input	5-18
	■ External add (EXT-ADD)	5-18
	■ External AM (EXT-AM)	5-19
5.5	Other settings	5-20
	■ Output range change (use with fixed range)	5-20
	■ Output on/off at power on	5-21
	■ LOAD function (equalize setting and output values)	5-22
	■ UNDO function	5-23
	■ Pulse generator function	5-24
	■ Phase sync	5-26
	■ Copy settings between channels	5-27
	■ Fixed frequency difference (2TONE)	5-28
	■ Fixed frequency ratio (RATIO)	5-29

• Following is a typical example of the display panel indications used in this Section.

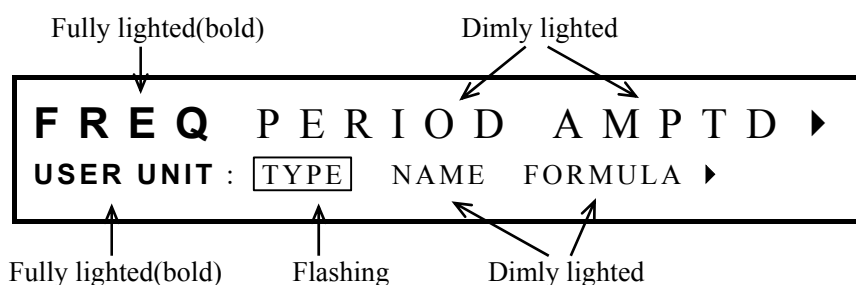

5.1 Convenient Settings

■ Frequency [Hz] setting by period [s] (→)

Operation is described for setting the waveform repetition rate not in frequency (Hz) but as period (s).

Operation:

- ① Press the  key, then the  key to produce the following display.

P	0 . 0 0 1 0 0 0 0 0 0 0 0 0	s
A 0 . 1 0 0 0 V p - p	O + 0 . 0 0 0 0 V	/ O P E N

- ② Set the period with the keypad or  dial.

Other:

The period setting is frequency with the reciprocal less than 0.01 μHz discarded. Thus, the setting tolerance is large when the frequency setting digits are fewer (period longer).

In this situation, even if setting is changed by the keypad or  dial, the actual oscillation period does not change in some cases.

■ Squarewave duty setting (→)

Operation to set the squarewave duty is described. The setting changes the width (%) of the pulse with respect to the overall waveform ( portion indicated by arrows).

Select squarewave ( variable duty).

Operation:

- ① Press the  key, then the  key to produce the following display.

D U T Y	5 0 . 0 0 0 0 %
1 0 0 0 . 0 0 0 0 0 0 0 H z	A 0 . 1 0 0 0 V p - p / O P E N

- ② Set the duty with the keypad or  dial.

Other:

- The table indicates the effects on other parameters when the frequency, period, width or duty is changed.

Change ↓	Frequency (FREQ)	Period (PERIOD)	Pulse width (WIDTH)	Duty (DUTY)
Frequency (FREQ)		Changed	Changed	Unchanged
Period (PERIOD)	Changed		Unchanged	Changed
Pulse width (WIDTH)	Unchanged	Unchanged		Changed
Duty (DUTY)	Unchanged	Unchanged	Changed	

- Due to the oscillation period and duty relationship, the pulse can be lost when the actual pulse width is less than 6.25 ns. An error message is displayed at this type of setting.
Also, jitter increases when the pulse width is less than 100 ns. A warning message is displayed at this type of setting.
- The actual waveform duty resolution is [oscillation frequency] ÷ [approx. 160 MHz] (0.0001 % at minimum). When the stop level is on, the minimum actual waveform duty resolution is approximately 0.003 %.

- If the pulse width of the  square wave (variable duty) is 6.25 ns or less, pulses may disappear depending on the relationship between the period and duty. Such a setting causes an error message to be displayed.

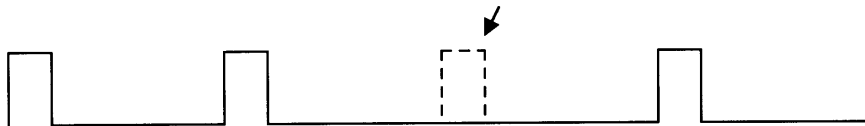

If the pulse width is 100 ns or less, jitter increases in comparison with the pulse width, and a warning message is displayed.

If the pulse width becomes 6.25 ns or less, pulses may disappear.

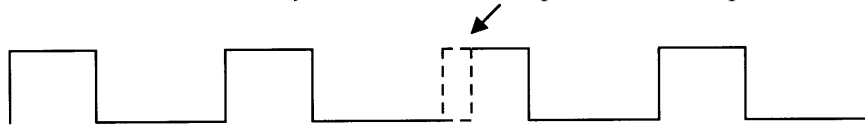

If the pulse width becomes 100 ns or less, jitter increases in comparison with the pulse width.



- If the phase of the  square wave (fixed duty) or  square wave (variable duty) is changed, multiple pulses may be output in one period, as shown below:

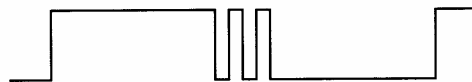

- If the duty of the  square wave (variable duty) is changed, multiple pulses may be output in one period, as shown below:

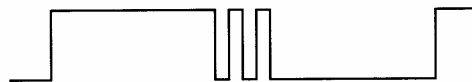

If the pulse width is larger than 75 ns after the duty is changed, it is possible to suppress the output of multiple pulses. For this purpose, set DUTY-VALID to CYCLE.

If the oscillation mode is sweep or modulation, however, this setting has no meaning.

```

I M M E D   C Y C L E   E X P A N D
SYSTEM : ◀ [DUTY-VALID] SYNC OUT
    
```

When DUTY-VALID is set to CYCLE, the duty will be reflected starting at the next period. If the frequency or phase is changed, extra pulses may be output even if DUTY-VALID is set to CYCLE.

Operation when DUTY-VALID: IMMED

The setting is reflected at the same time that the duty is changed

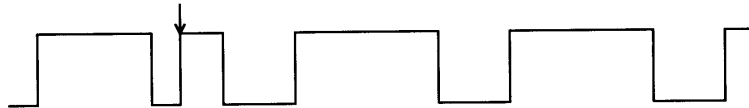

Operation when DUTY-VALID: CYCLE

Duty change

The setting is reflected starting at the next period

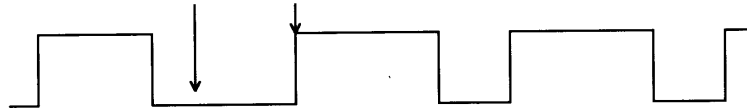



- The duty setting range for the \square square wave (variable duty) can be switched to 0.0000% to 100.0000% or 0.0100% to 99.9900%. To set the duty in the range of 0.0000% to 100.0000%, set DUTY-VALID to EXPAND.

<p>I M M E D C Y C L E E X P A N D</p> <p>SYSTEM : ◀ DUTY-VALID SYNC OUT</p>

However, it is not possible to set CYCLE and EXPAND simultaneously.

When DUTY-VALID is set to IMMED or CYCLE, the duty setting range becomes 0.0100% to 99.9900%. When the frequency is approximately 16 kHz or less, pulse losses can be prevented by restricting the duty range to 0.0100% to 99.9900%.

■ **Squarewave pulse width setting** ( → )

Operation to set the squarewave pulse width is described. The setting changes the width of the pulse (portion indicated by arrows  ).

Select squarewave ( variable duty).

Operation:

- ① Press the  key, then the  key to produce the following display.

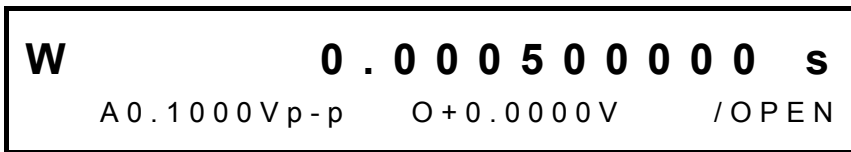

- ② Set the width with the keypad or  dial.

Other:

- The table indicates the effects on other parameters when the frequency, period, width or duty is changed.

Change ↓	Frequency (FREQ)	Period (PERIOD)	Pulse width (WIDTH)	Duty (DUTY)
Frequency (FREQ)		Changed	Changed	Unchanged
Period (PERIOD)	Changed		Unchanged	Changed
Pulse width (WIDTH)	Unchanged	Unchanged		Changed
Duty (DUTY)	Unchanged	Unchanged	Changed	

- Due to the oscillation period and duty relationship, the pulse can be lost when the actual pulse width is less than 6.25 ns. An error message is displayed at this type of setting.
- Also, jitter increases when the pulse width is less than 100 ns. A warning message is displayed at this type of setting.

■ Amplitude and DC offset setting by high and low level (→ /)

Operation to set the waveform vertical size as high and low level, in place of amplitude and DC offset, is described.

Select the waveform type for squarewave.

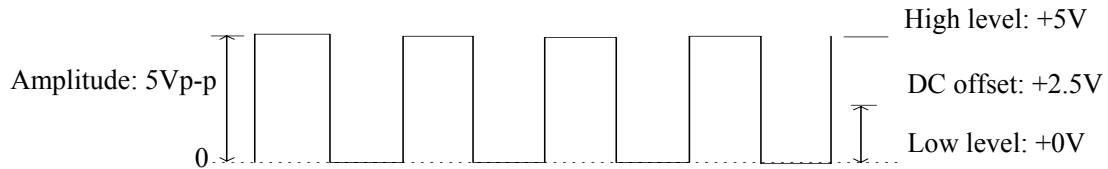

Operation:

- ① Press the  key, then the  key to produce the following display.

```

HIGH          + 0 . 0 5 0 0  V
1000.00000000Hz  L-0.0500V  /OPEN
  
```

- ② Set the High level with the keypad or  dial.

For example, set to +5 V.

- ③ Press the  key, then the  key to produce the following display.

```

LOW          - 0 . 0 5 0 0  V
1000.00000000Hz  H+5.0000V  /OPEN
  
```

- ④ Set the Low level with the keypad or  dial.

For example, set to +0 V.

5.1 Convenient Settings

Other:

The table indicates the effects on other parameters when the amplitude, DC offset, high level or low level is changed

Change ↓	Amplitude (AMPTD)	DC offset (OFFSET)	High level (HIGH)	Low level (LOW)
Amplitude (AMPTD)		Unchanged	Changed	Changed
DC offset (OFFSET)	Unchanged		Changed	Changed
High level (HIGH)	Changed	Changed		Unchanged
Low level (LOW)	Changed	Changed	Unchanged	

- Due to the relationships between high and low level settings, and between amplitude and DC offset settings, when the output voltage exceeds the following values, the Over lamp flashes and the output is clipped in some cases.

10 V range: Approx. 11 V peak/open time



1 V range: Approx. 1.1 V peak/open time

5.2 Units

■ Engineering unit (μ , m, k, M) display

Operation is described for displaying engineering units (e.g., the k of 1 kHz). As an example, the frequency units are changed.

Operation:





- ① Press the  key, then the  key.

1 0 0 0 . 0 0 0 0 0 0 0 0 H z
A 0.1000V p-p 0+0.0000V /OPEN

- ② Press the  key to change the display as follows.

1 . 0 0 0 0 0 0 0 0 0 0 0 0 k H z
A 0.1000V p-p 0+0.0000V /OPEN



Other:

- **Unit change enable:** Only when the , ,  or  key is lighted.
- **Initializing units (e.g., from kHz to Hz):** At above step②, press the  key.

■ Amplitude units change

Operation to change the amplitude units is described. For example, set to Vrms.

Operation:

- ① Press the  key, then the  key.
- ② Press the  key to produce the following display (Vp-p lights).

A M P T D	0 . 1 0 0 0	V p - p
1000.0000000Hz	O+0.0000V	/OPEN

- ③ Turn the  dial to produce the following display.

A M P T D	0 . 0 3 5 4	V r m s
1000.0000000Hz	O+0.0000V	/OPEN

Other:

- The following units can be used.
 - Vp-p, Vrms, dBV, dBm (*1), USER (*2)
 - *1: Selectable when LOAD function is SET.
 - *2: Set User units name is displayed.
- Notes: Only Vp-p and USER can be selected when the oscillation mode is NOISE.
Only Vp-p and USER can be selected when the selected waveform is ARB.
- Even if the amplitude units are changed, the actual output voltage does not change.



■ User-unit setting (→ USER-UNIT)

Operation for changing the units by using the user unit function is described.

For example, set for expressing frequency as rpm (revolutions per minute, e.g., engine rotation).



Operation:

(1) Select setting type, for example, frequency

- ① Press the  key, then use the  and  keys to produce the following display (USER-UNIT flashes).



```

USER UNIT MENU
SYSTEM : RANGE  PRESET  USER-UNIT ▶
  
```

- ② Press the  key, then use the  and  keys to produce the following display (TYPE flashes).

```

FREQ PERIOD AMPTD ▶
USER UNIT : TYPE  NAME  FORMULA ▶
  
```



- ③ Again press the  key, then use the  and  keys to produce the following display (FREQ flashes).

```





FREQ  PERIOD AMPTD ▶
USER UNIT : TYPE  NAME  FORMULA ▶
  
```

- ④ This selects the setting type to frequency. Press the  key once to release the type select mode.

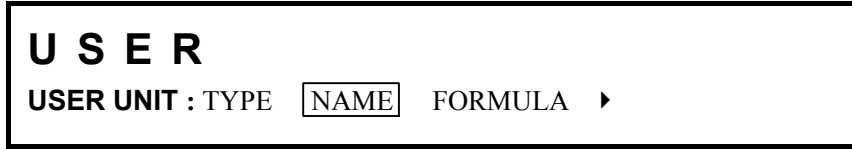
(2) Set the unit NAME (e.g., rpm)

- ① Use the  and  keys to produce the following display (NAME flashes).





- ② Press the  key, then use the  dial and  and  keys to input the unit name (e.g., rpm). Up to 4 of the following characters can be used for the unit name.



abcdefghijklmnopqrstuvwxyz ▾ (space)
 ABCDEFGHIJKLMNOPQRSTUVWXYZ0123456789
 !"#%\$%&'()*+,-./:;<=>@[¥]^_`{|}→←

- ③ After inputting, press the  key once to release unit name setting.

(3) Select the FORMULA, for example, (h+n)*m. The setting type (e.g., frequency) is h, n is offset, and m is the coefficient.

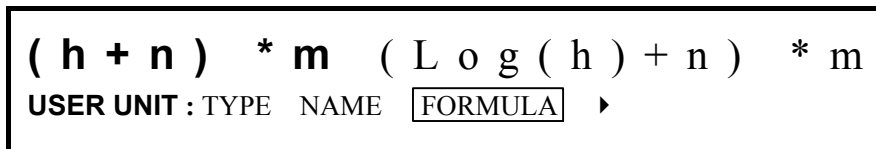
- ① Use the  and  keys to produce the following display (FORMULA flashes).



- ② Press the  key, then use the  and  keys to produce the following display [(h+n)*m flash].





- ③ This sets the formula to (h+n)*m. Press the  key once to release the formula setting mode.



(4) Set the coefficient [SCALE (m)], e.g., to 60

- ① Use the  and  keys to produce the following display (SCALE (m) flashes).



+ 1 . 0 0 0 0 0 0 0 0 0 0 0 0 0 0 0 0 E + 0 USER UNIT : ◀ SCALE (m) OFFSET (n)

- ② Press the  key, then set the scale with the keypad or  dial.
- ③ Press the  key to release the scale setting mode.



(5) Set the offset [OFFSET (n)], for example, to 0

- ① Use the  and  keys to produce the following display [OFFSET (n) flashes].

+ 0 . 0 0 0 0 0 0 0 0 0 0 0 0 0 0 0 0 E + 0 USER UNIT : ◀ SCALE(m) OFFSET (n)
--

- ② Press the  key, then set the offset with the keypad or  dial.
- ③ Press the  key to release the offset setting mode.

(6) Display the above settings

- ① Press the  key, then the  key.
- ② Press the  key to produce the following display (Hz flashes).

1 0 0 0 . 0 0 0 0 0 0 0 0 H z A 0 . 1 0 0 0 V p - p O + 0 . 0 0 0 0 V / O P E N
--

- ③ Turn the  dial to produce the following display.

6 0 0 0 0 . 0 0 0 0 0 0 0 0 r p m A 0 . 1 0 0 0 V p - p O + 0 . 0 0 0 0 V / O P E N
--

Other:

- User units can be used for frequency, period, amplitude, DC offset, phase and duty. Also, CH1 and CH2 can be set independently.

However, at the channel mode difference (DIFF) setting, all CH1 user unit settings (formula, name, coefficient and offset) are copied to CH2.

 “3.3 Basic operation (■ Channel modes and settings)”, cf.

- Even when user units are set, the actual output does not change.
- According to the coefficient and offset settings, setting resolution may be less precise when user units are used.
- When using user units for the DC offset and phase in LOG selection, note the following.

If a negative value is set before conversion to the user unit is made, an attempt is made to calculate the logarithm of a negative value to display the user setup value. Since the logarithm of a negative value cannot be a real number, "OVER" is displayed.



Thereafter, user setup values can be changed arbitrarily. However, the DC offset and phase cannot be converted to a negative value while user units are being used.

5.3 Setting memory



■ Setting store (: STORE)

Operation is described for saving frequency, amplitude and other settings in memory.





Operation:

- ① Press the  key, then use the  and  keys to produce the following display (STORE flashes).

S T O R E M E N U
MEMORY : STORE RECALL CLEAR

- ② Press the  key, then use the  and  keys to produce the following display (0 flashes).

(N O T S T O R E D)
STORE : 0 1 2 3 4 5 6 7 8 9

- ③ Press the  key, then apply a desired name to the memory (may also be omitted). Select characters with the  dial and shift position with the  and  keys. Up to 20 characters can be selected from the following list.

abcdefghijklmnopqrstuvwxyz ▾ (space)
ABCDEFGHIJKLMNOPQRSTUVWXYZ0123456789
!"#\$%&'()*+,-./:;<=>@[¥]^_`{|}→←

- ④ Press the  key to store the name (in this example, save to memory 0).

The above completes memory storage. Press the  key to release the storage mode.



Other:

- By pressing the keypad at above step ②, name input is omitted and storage is at the memory of the depressed number.



■ Setting recall (: RECALL)

Operation to recall settings from memory is described.

Operation:

- ① Press the  key, then use the  and  keys to produce the following display (RECALL flashes).

R E C A L L M E N U		
MEMORY : STORE	RECALL	CLEAR

- ② Press the  key, then use the  and  keys to produce the following display (0 flashes). In this example, TEST 1 is recalled from memory.

T E S T 1										
STORE :	0	1	2	3	4	5	6	7	8	9

- ③ Press  key for recall.



Other:

- If the keypad is pressed at above step ②, the pressed memory number is recalled. Only the stored numbers of the keypad light.
- Items stored in the setting memory and user unit settings are noted in Section [3.3 Basic operation, Setting initialize]. The following items do not change before and after recall.
 - Channel selection
 - Output on/off
 - Output on/off state at power on
 - Arbitrary waveform parameter
 - Type of remote control
 - GPIB parameter
 - USB ID

■ Setting memory clear (: CLEAR)



Operation to clear the memory is described. The operation also clears names entered in the memory.

Operation:

- ① Press the  key then use the  and  keys to produce the following display (CLEAR flashes).

C L E A R M E N U

MEMORY : STORE RECALL CLEAR

- ② Press the  key, then use the  and  keys to produce the following display (0 flashes). In this example, TEST 1 is cleared from memory.

T E S T 1

CLEAR : 0 1 2 3 4 5 6 7 8 9

- ③ Press  key to clear the memory recall.

Other:

- At above step ②, pressing the keypad clears the corresponding memory number. Only the stored numbers of the keypad light.



5.4 External input

■ External add (EXT-ADD) (: EXT-ADD)



Operation is described for adding an external signal to the WF1966 output. The external signal is connected to the rear panel EXT ADD IN connector.

 For details on connectors, “3.4 Input and output connectors (■External add input (EXT ADD IN))”, cf.

Operation:

- ① Press the  key, then use the  and  keys to produce the following display (EXT-ADD flashes).

O F F O N
SYSTEM : ◀ EXT-AM EXT-ADD φ SYNC ▶

- ② Press the  key, then use the  and  keys to produce the following display (ON flashes).



O F F O N
SYSTEM : ◀ EXT-AM EXT-ADD φ SYNC ▶

■ External AM (EXT-AM) (: EXT-AM)



Operation to modulate the WF1966 output with an external AM signal is described. The external signal is applied to the rear panel EXT AM IN connector.

 For details on connectors, “3.2 Input and output connectors (■External add input (EXT ADD IN))” cf.

Operation:

- ① Press the  key, then use the  and  keys to produce the following display (EXT-AM flashes).

<p>O F F O N</p> <p>SYSTEM : ◀ EXT-AM EXT-ADD φSYNC ▶</p>
--

- ② Press the  key, then use the  and  keys to produce the following display (ON flashes).

<p>O F F O N</p> <p>SYSTEM : ◀ EXT-AM EXT-ADD φSYNC ▶</p>
--

Other:

- AM appears at the head of the display when external AM is on.

<p>1 0 0 0 . 0 0 0 0 0 0 0 0 H z</p> <p>AM A0.1000V p-p O+0.0000V /OPEN</p>
--

5.5 Other settings



■ Output range change (use with fixed range) (: RANGE)

Operation is described for fixing the voltage output range to 10 V.



Although AUTO is normally used, by fixing the range, output interruption from automatic switching can be avoided.

A disadvantage is during output voltage below 2 Vp-p (open), setting resolution is 1 digit less than the 1 V range.

Operation:

- ① Press the  key, then use the  and  keys to produce the following display (RANGE flashes).

```
A U T O   1 0 V   1 V
SYSTEM :  RANGE  PRESET  USER-UNIT ▶
```

- ② Press the  key, then use the  and  keys to produce the following display (10 V flashes).

```
A U T O   1 0 V   1 V
SYSTEM : RANGE  PRESET  USER-UNIT ▶
```



Other:

- When the amplitude setting is larger than 2 Vp-p (open) in the 1 V range, the amplitude is automatically changed to 1/10, since voltage exceeding 2 Vp-p (open) cannot be output in the 1 V range.



■ Output on/off at power on (: POWER - ON)

Selectable return to the state when the power supply was switched off or output on/off state. The example is setting the output for off at power on.

Operation:

- ① Press the  key, then use the  and  keys to produce the following display (POWER-ON flashes).

<p style="text-align: center;">L A S T - S T A T E O F F O N</p> <p>SYSTEM : ◀ POWER-ON REMOTE OPTION</p>

- ② Press the  key, then use the  and  keys to produce the following display (OFF flashes).



<p style="text-align: center;">L A S T - S T A T E O F F O N</p> <p>SYSTEM : ◀ POWER-ON REMOTE OPTION</p>

■ LOAD function (equalize setting and output values) (: LOAD)



Operation is described for equalizing the amplitude (AMPTD) and DC offset (OFFSET) setting values with the actual output values (FUNCTION OUT connector voltage).

The example is setting at the 100Ω load impedance.

Operation:

- ① Press the  key, then use the  and  keys to produce the following display (LOAD flashes).

O P E N
SYSTEM : ◀ LOAD COPY1→2 COPY2→1 ▶

- ② Press the  key, then turn the  dial to produce the following display (SET flashes).

S E T **5 0 Ω**
SYSTEM : ◀ **LOAD** COPY1→2 COPY2→1 ▶

- ③ Press the  key, then turn the  dial to set the load impedance to 100 Ω.

The above setting calculates the actual voltage of FUNCTION OUT connector from the WF1966 output impedance (50 Ω) and the load impedance for automatically changing the indicated value.

Other:

- The load impedance setting range is 45 to 999 Ω, resolution is 1 Ω.
- The WF1966 output impedance and voltage errors are not converted.



■ UNDO function

The UNDO function is described for returning a numerical or other setting to the previous state.

Operation:

- ① Press the  to return a setting to the previous state (ineffective when UNDO is extinguished).

Other:

- Undo enabled:
 1. Directly after changing frequency, amplitude, etc., with the keypad or MODIFY dial.
 2. Directly after setting recall ( → RECALL). Press the  key to return the state prior to recall.

■ Pulse generator function

Operation of the WF1966 as a pulse generator is described.

Operation:

(1) Set for continuous pulse output

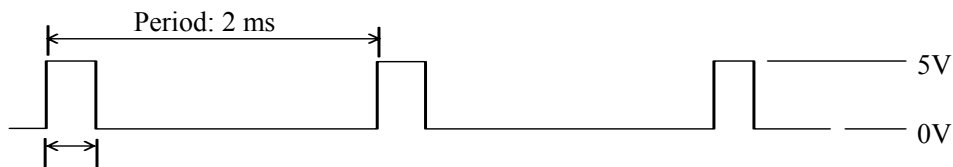







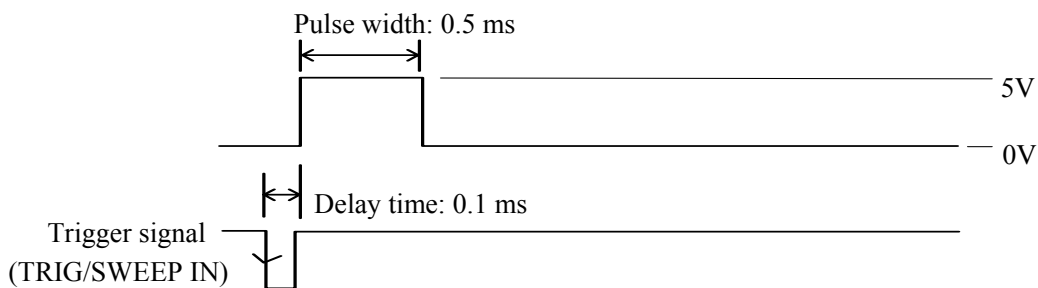

Pulse width: 0.2 ms

- ① Set the waveform to squarewave (variable duty), (→).
- ② Set the voltage High level to +5 V and the Low level to 0 V.
(→ → → , → → →)
- ③ Set the period to 2 ms (→ → →).
- ④ Set the pulse width to 0.2 ms (→ → → →).



(2) Use external trigger for pulse output



- ① Set the waveform to squarewave (variable duty), (→).
- ② Set the voltage High level to +5 V and the Low level to 0 V.
(→ → → , → → →)

- ③ Set the pulse width to 0.5 ms ( →  →  →  → ).
- ④ Set oscillation mode.
 ( →  → TYPE = TRIG, SOURCE = EXT  , DELAY = 0.1 ms,
 MARK = 1.0 cycle, STOP-LEVEL = ON -100%)
- ⑤ Apply the trigger signal to the TRIG/SWEEP IN connector.

Other:

- **Double pulse output:** At above step ④, set MARK = 2.0 cycles.
- **Manual trigger:** At above step ④, set SOURCE = EXT  and press the  key.
 (Do not connect anything to the TRIG/SWEEP IN connector.)

■ Phase sync (SYSTEM : ϕ SYNC)

Operation is described for restarting the CH1 and CH2 output waveforms from a set phase so as to clarify the phase relationship.

Phase sync is used when the channel mode is INDEP or operation of multiple units is synchronized using ϕ -SYNC IN/OUT (1991 synchronized operation option).

When the channel mode is changed, phase sync is processed automatically.

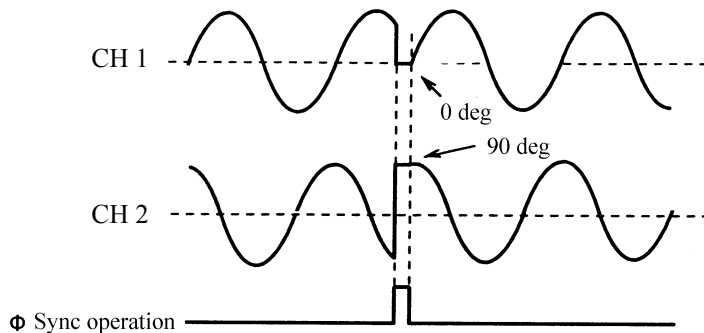

CH1 and CH2 waveform outputs in the INDEP channel mode when the phase is synchronized (CH1 is 0 deg. and CH2 is 90 deg.)

Operation:

- Press the SYSTEM key, then use the \leftarrow and \rightarrow keys to produce the following display (ϕ SYNC flashes).

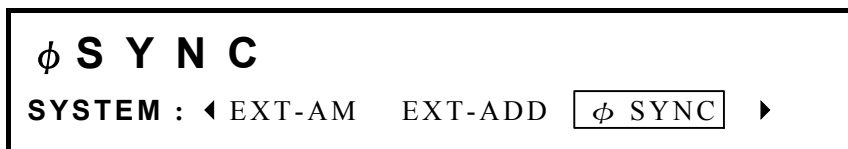

- Press the ENTER key to engage phase synchronization.

Other:

- A slight time difference remains between channels after phase sync when ϕ SYNC is conducted. This time difference is about 3 ns and specific to each product.

Use either of the following methods to compensate for the time difference:

- For applications that are used at certain frequencies only, it is easier to compensate by adjusting any of the channel phases.
- For applications that are used while frequencies change, compensating by adjusting the length of signal cable is effective.



A delay of about 5 ns occurs for each 1 m of the coaxial cable. At this point, proper termination with 50 Ω is required. The delay cannot be adjusted if updating affects the delay.

- ϕ SYNC is valid only when the oscillation mode is NORMAL. In other modes, the phase may shift 180 degrees from the setting value, or mark cycles/space cycles may be different from those occurring during burst oscillation.
- The phase between outputs of units in synchronized operation is the difference of the phase setting (PHASE) set for each unit (channel).



■ Copy settings between channels (: COPY1 → 2 / COPY2 → 1)

Operation to copy settings from CH1 to CH2 (or vice versa) is described.

Operation:

- ① Press the  key, then the  and  keys to produce the following display (COPY 1 → 2 flashes).

COPY CH1 → CH2
SYSTEM : ◀ LOAD COPY1→2 COPY2→1 ▶

- ② Press the  key, COPY CH1 → CH2 flashes. Then again press the  key to copy between the channels.

This completes setting copy.

To copy from CH2 to CH1, at above step ①, flash COPY 2→1.

Other:

- The following items do not change before and after copying.
 - Channel select
 - Output on/off
 - Arbitrary waveform related
 - User units related * : When the copy from settings are user units, the copy to settings are also user units. When user units are used for the respective channel settings (formula, name, coefficient, offset), the settings are determined so as to provide uniform final output values.
 - Type of remote control
 - GPIB parameter
 - USB ID



■ Fixed frequency difference (2TONE) (: 2TONE)

Following is a description of the 2 tone channel mode whereby a fixed frequency difference is maintained between CH1 and CH2.

In this mode, if the frequency of either channel is changed, the frequency of the other channel is automatically changed to maintain the fixed difference.

Operation:





(1) Set the channel mode to 2 tone.

- ① Press the  key, then the  and  keys to produce the following display (2 TONE flashes).



- ② Press the  key to select this channel mode.

(2) Set the frequency difference (Δ FREQ) between CH2 and CH1.

- ① Press the  key, then the  key.
- ② Set the frequency difference with the keypad or  dial.
- ③ Press the  key once to release the setting mode.

Other:

- If the frequency difference (Δ FREQ) is changed, the frequency of CH2 changes.
- The frequency difference (Δ FREQ) cannot be a negative value.
- If the channel mode is set to the fixed frequency difference (2TONE), the frequency of CH2 changes according to the frequency difference (Δ FREQ).



■ Fixed frequency ratio (RATIO) (: RATIO)

Following is a description of the ratio channel mode whereby a fixed frequency ratio is maintained between the frequencies of CH1 and CH2 (or vice versa).

In this mode, if the frequency of either channel is changed, the frequency of the other channel is automatically changed to maintain the fixed ratio.

Operation:



(1) Set the channel mode to ratio

- ① Press the  key, then the  and  keys to produce the following display (RATIO flashes).





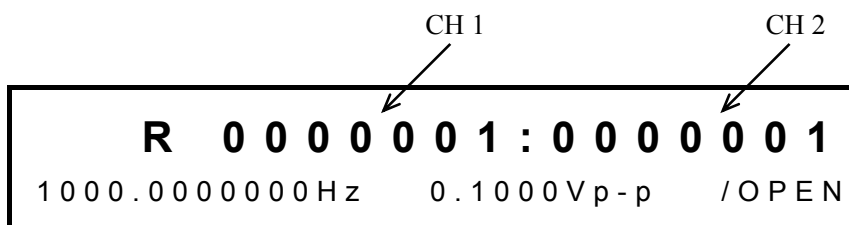

- ② Press the  key to select this channel mode.

(2) Set the frequency ratio between CH2 and CH1.

- ① Press the  key, then the  key.



- ② Select the affected channel with the  and  keys, then set the frequency ratio with the keypad or  dial.
- ③ Press the  key once to release the setting mode.

Other:

- If the channel mode is set to the fixed frequency ratio (RATIO), the frequency of CH2 changes according to the frequency ratio (RATIO).
- In RATIO mode, the frequency resolution is equal to 10 nHz multiplied by the frequency ratio set for the channel.

Section 6 Troubleshooting

6.1 Error message	6-2
■ Power on error	6-2
■ Operation error	6-3
6.2 Suspected failure	6-6
■ In case of abnormality	6-6

6.1 Error message

Self-check is conducted at power on and in case of an abnormality, an error message is displayed. An error message is also displayed if an erroneous operation is conducted.

Error message contents, causes and corrective measures are indicated in the following tables.

■ Power on error

Error message	Cause	Corrective measures
BACKUP MEMORY LOST	Battery backup memory contents destroyed.	Backup battery probably depleted. Contact dealer. Press the ENTER key to start the system at the factory settings.
CALIBRATION MEMORY LOST	Calibration data destroyed.	Contact dealer. Although possible to start by pressing the ENTER key, accuracy cannot be guaranteed.
SYSTEM TEST FAILED 001	Internal ROM sum check error.	Contact dealer.
SYSTEM TEST FAILED 002	Internal RAM read/write error.	Contact dealer.

■ **Operation error**

Error message	Cause or corrective measures
DATA OUT OF RANGE	Input values outside of permissible setting range. Confirm permissible setting range and again input. Upper and lower limits can be easily checked by using the MODIFY dial to change the values.
INVALID NUMERIC DATA	Keypad input data invalid (e.g., decimal point only).
SETTINGS CONFLICT 001	Start or stop value set to 0 during LOG sweep and sweep cannot be executed.
SETTINGS CONFLICT 002	Combined center and span exceed the permissible sweep type (e.g., frequency) setting range.
SETTINGS CONFLICT 003	Combined modulation type (e.g., frequency) and Deviation exceed the permissible modulation type setting range and modulation cannot be executed.
SETTINGS CONFLICT 004	Combined modulation type (e.g., frequency) and Deviation or Depth exceed the permissible modulation type setting range.
SETTINGS CONFLICT 007	Combined period and pulse width exceed the permissible duty setting range.
SETTINGS CONFLICT 008	Combined frequency (FREQ) and frequency difference (Δ FREQ) or frequency ratio (RATIO) settings exceed the permissible frequency setting range.
SETTINGS CONFLICT 009	Combined frequency and duty exceed the permissible tr/tf setting range.
SETTINGS CONFLICT 010	Since the mode is SWEEP or MODU for \square (variable duty), DUTY-VALID cannot be set.

continued next page

continued from previous page

Error message	Cause or corrective measures
STORE/RECALL MEMORY LOST	Setting storage memory contents destroyed and settings cannot be recalled. Contact dealer.
WARNING 001	Combined frequency and duty set the pulse width to not more than 6.25 ns and the pulse may be lost.
WARNING 002	Because the pulse width is set to 6.25 ns to 100 ns due to the combination of frequency and duty, the pulse width may become unstable (large jitter component).
WARNING 003	Since high frequency, burst oscillation mark and space may be unstable.
WARNING 004	Low level setting changed due to high level setting change, or conversely, high level setting changed due to low level setting change.
WARNING 005	Changed to simple standard units (Hz, s, Vp-p, V).
WARNING 006	Since combined period and pulse width exceed the permissible duty setting range, pulse width was changed in order to enter the permissible duty range. Since the permissible tr/tf setting range by combined frequency and duty changed, tr/tf was changed to be within the setting range.
WARNING 007	Changing the frequency relationship exceeded the permissible frequency setting range for the other channel. Therefore, the frequency relationship of both channels was changed to within this range.
WARNING 008	Because of channel mode change, the oscillation mode was changed to normal.

continued from previous page

Error message	Cause and treatment
WARNING 009	<p>Due to channel mode change, the oscillation mode was changed to normal.</p> <p>The sweep/modulation type was changed to frequency.</p> <p>Therefore the other channel sweep/modulation was changed to frequency.</p> <p>Sweep/modulation type was changed to a type other than frequency, or the oscillation mode was changed to other than sweep/modulation.</p> <p>Therefore, the oscillation mode of the other channel was changed to normal.</p>
WARNING 010	The sweep function was changed from LOG to LIN.
WARNING 011	The sweep mode was changed from gated to single.
WARNING 012	Since the oscillation mode of the other channel was changed during sweep or modulation, sweep or modulation was stopped.
WARNING 013	Sweep time or modulation frequency exceeded the settable range and was automatically changed to within the permissible setting range.
WARNING 015	Because of DUTY-VALID change, the duty was changed to 0.01% or 99.99%.
WARNING 016	Because of a mode change, DUTY-VALID was changed to IMMED.

6.2 Suspected failure

■ In case of abnormality

If an abnormality is suspected, check as indicated in the following table. If normal operation cannot be returned, contact the dealer.

Symptom	Possible causes	Correction
No power on	Power source not within specified range	Use the power source within the specified range.
	Power supply fuse open	Replace the power supply fuse. (Be sure to use the correctly rated fuse.)
	External noise	Install the equipment in a site with favorable conditions.
Panel inoperative	Remote mode enabled	Press the LOCAL key to set the local mode.
	Keys or Modify dial defective	Contact service.
Output abnormal	Ambient temperature and humidity outside specified range	Use the equipment under the specified environmental conditions.
	Inadequate warm up	Allow the equipment to warm up for at least 30 minutes after power on.
	DC offset applied	Set DC offset to 0 V.
	External AM is on.	Switch off the external AM.
	Set for user units	Select standard units
	LOAD function being used	Set for OPEN.
Cannot be set via remote control	Address or USB ID different from that in the program	Set the address and USB ID to match those in the program.
	Address or USB ID identical to that of another device	Set the address and USB ID so that they do not match those of other devices.
Does not operate according to instruction manual	Settings have been initialized (PRESET)	The instruction manual presumes the settings have been initialized.
	Operated channel reversed	Check if CH1 or CH2.

Section 7 Maintenance

7.1	Outline	7-2
	■ Work contents	7-2
	■ Required test instruments	7-2
7.2	Operation checks	7-3
	■ Preparatory checks	7-3
	■ Function checks	7-3
7.3	Performance tests	7-5
	■ Performance tests	7-5
	■ Preparatory checks	7-5
	■ Test preparation	7-5
	■ Frequency accuracy	7-5
	■ Amplitude accuracy	7-6
	■ DC offset accuracy	7-6
	■ Amplitude vs. frequency characteristics	7-7
	■ Sinewave distortion	7-7
	■ Squarewave response	7-8
	■ Duty factor	7-8
	■ Time difference between channels	7-9

7.1 Outline

■ Work contents

The following types of maintenance are required in order to use the equipment in optimum condition.

- Inspection Check that the equipment is operating correctly.
- Performance tests Check that the equipment meets specifications.
- Adjustment and calibration When the equipment does not meet specifications, it is adjusted and calibrated in order to restore performance at the manufacturer.
- Service Cause and location of failure are investigated and repair is conducted at the company.

This instruction manual provides easily carried out procedures for inspection and performance checks. Consult the manufacturer or dealer regarding more thorough inspection, adjustment, calibration and repair.

WARNING

Do not remove external covers.

Internal inspection of this equipment must be performed only by a trained service technician who is fully aware of the hazards involved.

■ Required test instruments

The following equipment is required for inspection and performance tests.

- Oscilloscope At least 100 MHz bandwidth
- Universal counter Reference oscillator accuracy better than 5×10^{-7}
- DC voltmeter Accuracy better than 0.1 %
- AC voltmeter 1 True rms, accuracy better than 0.3 %, bandwidth at least 100kHz
- AC voltmeter 2 True rms, accuracy better than 1 %, bandwidth at least 100MHz
- Distortion meter Full scale 0.1 %, frequency up to 100 kHz
- 50 Ω feed through terminator
- 50 Ω 20 dB attenuator

7.2 Operation checks

■ Preparatory checks

Check the following before inspection.

- Power source voltage is within specified range.
- Ambient temperature is within 5 to 35 °C.
- Ambient relative humidity is within 5 to 85 %RH (absolute humidity: 1 to 25 g/m³)
- Condensation is absent.

■ Function checks

- Power on

Confirm absence of error message at power on.

If an error message appears,  6. Troubleshooting.



















If an abnormal indication appears at power on, switch power off and wait at least 5 seconds, then again switch power on.

- Main function checks

To avoid setting error, initialize the settings ( → PRESET).

Connect FUNCTION OUT to an oscilloscope with 50 Ω coaxial cable to monitor the output.

Operate to change the following settings several times and confirm normal functions. Test both keypad and MODIFY dial for settings such as frequency.

- Frequency ( → )
- Amplitude ( → )
- DC offset ( → )
- Waveform ( →  ,  ,  Duty fixed 50 % ,  , )
- Duty ( →  Variable duty,  → )
- Output on/off ( , )

- Backup function

Switch off the power, wait at least 5 seconds, then switch the power on.

Confirm the settings for the following items prior to switching off the power have been correctly saved.

- Frequency
- Amplitude
- DC offset
- Waveform
- Duty

If stored at room temperature, the backup period is typically 3 years, but may vary among individual units and usage conditions.

To prevent any loss of setting information resulting from a depleted battery, regular battery replacement is recommended.

- GPIB/USB

Conduct some of the main function checks via GPIB/USB and confirm the same output variations.

Also note that the remote (REM) indicator lights.

Press the LOCAL key and confirm the remote indicator extinguishes and the local mode is returned (not local lock out).

7.3 Performance tests

■ Performance tests

Performance tests are an important part of preventive maintenance and serve to prevent serious deterioration of the equipment performance.

Conduct these tests at incoming inspection, routine inspection, following repair and whenever performance needs to be confirmed.



When specifications are not met in performance tests, service is required. Contact the dealer.

■ Preparatory checks

Check the following before testing performance.

- Power source voltage is within specified range.
- Ambient temperature is 23 ± 5 °C.
- Ambient relative humidity is within 20 to 70 % RH.
- Condensation is absent.
- Allow at least 30 minutes warm up.

■ Test preparation

- Signal cables are 50 Ω coaxial, RG-58A/U or thicker, less than 1 meter length and fitted at both ends with BNC connectors.
- Where items call for 50 Ω termination, set the input impedance of the connected instrument to 50 Ω . Where this is impossible, use a 50 Ω feed through terminator at the test instrument input.
- Initialize the settings for each test item ( \rightarrow [PRESET]), set the output on (key internal LED lights according to  or ) and the item to be changed is indicated.

■ Frequency accuracy

Connection: Use coaxial cable to connect FUNCTION OUT to a universal counter (50 Ω termination).

Setting: Initialize, then set frequency to 1 MHz and amplitude to 20 Vp-p/open.







Measurement: Measure frequency with the universal counter (CH1).

Judgment: Normal if within ± 5 ppm (999.995 to 1.000005 MHz) (when shipped)

However, since aging may occur with up to ± 3 ppm/year, deterioration up to ± 8 ppm (999.992 to 1.000008 MHz) may have occurred if one year has passed since shipment.

■ Amplitude accuracy

- Connection: Use coaxial cable to connect FUNCTION OUT to AC voltmeter 1.
- Setting: After setting initialize, set the amplitude, output range and waveform as indicated in the following table.
- Measurement: Measure the true rms output voltage for each waveform. (CH1,CH2)
- Judgment: The normal ranges are indicated in the table.

Waveform	Output range	Setting	Normal range
	10 V	20 Vp-p/open (7.071 Vrms/open)	6.983 to 7.159 Vrms
	10 V	20 Vp-p/open (5.774 Vrms/open)	5.701 to 5.846 Vrms
	10 V	20 Vp-p/open (10.00 Vrms/open)	9.875 to 10.125 Vrms
	10 V	10 Vp-p/open (3.536 Vrms/open)	3.483 to 3.589 Vrms
	10 V	5 Vp-p/open (1.768 Vrms/open)	1.732 to 1.803 Vrms
	10 V	2 Vp-p/open (0.707 Vrms/open)	0.682 to 0.732 Vrms
	1 V	2 Vp-p/open (0.7071 Vrms/open)	0.697 to 0.718 Vrms





■ DC offset accuracy

- Connection: Connect FUNCTION OUT to a DC voltmeter.
- Setting: After setting initialize, set the DC mode, output range and DC offset as indicated in the following table.
- Measurement: Measure the output voltage. (CH1,CH2)
- Judgment: The normal ranges are indicated in the table.

Output range	DC offset setting	Normal range
10 V	±10.000 V/open	±9.850 to ±10.150 V
10 V	±5.000 V/open	±4.875 to ±5.125 V
10 V	±2.000 V/open	±1.890 to ±2.110 V
10 V	±1.000 V/open	±0.895 to ±1.105 V
10 V	0.000 V/open	-0.100 to +0.100 V
1 V	±1.0000 V/open	±0.985 to ±1.015 V
1 V	0.0000 V/open	-0.010 to +0.010 V

■ Amplitude vs. frequency characteristics

- Connection: Use coaxial cable to connect FUNCTION OUT to AC voltmeter 2 (50 Ω termination).
- Setting: Initialize, then set the amplitude to 20 Vp-p/open and select the frequency and waveform as indicated in the table.
- Measurement: Measure the true rms output voltage for each frequency and waveform. (CH1,CH2)
- Judgment: The normal ranges are indicated in the table.

Waveform	1 kHz Setting	100 kHz Setting	to 1 MHz	to 5 MHz	to 10 MHz	to 20 MHz	to 50 MHz
	—————	(Reference value)	± 0.2 dB	+0.2/-0.5 dB	+0.2/-1.0 dB	+0.3/-1.5 dB	+1.0/-3.0 dB
	(Reference value)	—————	± 0.3 dB	—————	—————	—————	—————
	(Reference value)	—————	± 0.3 dB	—————	—————	—————	—————
	(Reference value)	—————	± 0.5 dB	—————	—————	—————	—————
	(Reference value)	—————	± 0.5 dB	—————	—————	—————	—————

■ Sinewave distortion

- Connection: Use coaxial cable to connect FUNCTION OUT to a distortion meter (50 Ω termination).
- Setting: Initialize, then set the amplitude to 20 Vp-p/open and the frequency as indicated in the table.
- Measurement: Measure the distortion (CH1,CH2)
- Judgment: The normal range is indicated in the table.

Frequency	Normal range
10 Hz to 100 kHz	0.3 % or less

(Bandwidth 500 kHz)

■ **Squarewave response**

- Connection: Use coaxial cable to connect FUNCTION OUT to an oscilloscope (50 Ω termination).
- Setting: Initialize, and then set \square , the frequency to 1 MHz, the amplitude to 20 Vp-p/open, and tr/tf to 7 ns.
- Measurement: Observe the waveform and measure the rise and fall times, overshoot and undershoot.
- Judgment: The normal range is indicated in the table.

Item	Normal range
Rise and fall times	10 ns or less
Overshoot and undershoot	5 % or less

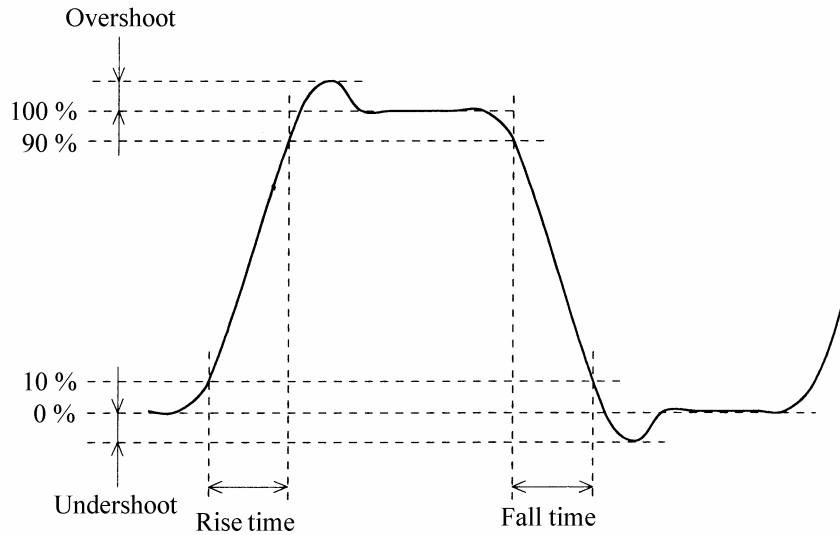



■ **Duty factor**

- Connection: Use coaxial cable to connect Function Out to a universal counter (50 Ω terminated).
- Settings: Initialize the settings, then set amplitude to 20 Vp-p, and waveform and frequency according to the following table.
- Measurement: Set the counter rise and fall period to the interval timer mode and measure the duty (time). Use the average value, since jitter will cause dispersion in the measurement values.
- Determination: The ranges indicated in the following table are normal.

Waveform	Frequency	Rated range
\square (duty 50 % fixed)	1 MHz	490 to 510 ns
\square (duty 50 % fixed)	10 MHz	45.0 to 55.0 ns
\square (duty 50 % fixed)	50 MHz	6 to 14 ns
\square (duty variable)	100 kHz	4.90 to 5.10 μs

■ Time difference between channels

- Connections: CH1 Function Out to universal counter input 1 (50 Ω terminated)
 CH2 Function Out to universal counter input 2 (50 Ω terminated)
 Use the same length and same type coaxial cables.
- Settings: After setting initialize, set channel mode 2PHASE, amplitude 20 Vp-p/open (CH1 and CH2), CH2 phase 180 deg, and frequency and waveform according to the following table.
- Measurement: Set timer mode between counter inputs 1 and 2, and measure the time difference between CH1 and CH2. Set the counter trigger level to 0 V and the trigger polarity to rising for both inputs 1 and 2. Use the average value, since dispersion occurs in the measured values.
- Determination: The ranges indicated in the following table are normal.

Waveform	Frequency	Rating range
	10 MHz	25 to 75 ns
 (duty 50 % fixed)	10 MHz	25 to 75 ns
	500 kHz	975 to 1025 ns

Section 8 Specifications

8.1	Waveform and output characteristics	8-2
8.2	Output voltage	8-4
8.3	Other functions	8-5
8.4	Initialized settings	8-11
8.5	Remote control	8-12
8.6	Options	8-13
8.7	General items	8-14
	■ External drawing	8-15

Guaranteed values are shown with tolerance, values without tolerance are for reference.

Noise	<p>Noise source: pseudo-M-series by 45-step shift register Period 53.406 hours, Spectrum interval 5.2013 μHz</p> <p>White noise bandwidth (equivalent noise bandwidth): about 2 MHz</p> <p>Peak factor (crest factor): 3 Set the amplitude to V_{p-p}. The output amplitude becomes half the set amplitude. Effective value = $(V_{p-p} \text{ set point}) \div 4 \div (\text{peak factor})$</p> <p>Binary output: Outputs from SYNC OUT during NOISE mode.</p>
-------	--

● Output characteristics (FUNCTION OUT)

Amplitude frequency characteristics	<p>Continuous oscillation, External AM off, 50Ω load, DC offset 0 V, amplitude setting 10 $V_{p-p}/50 \Omega$, frequency 100 kHz (\sim)/1 kHz (other than \sim) reference, effective value measured</p> <p>\sim Up to 1 MHz: ± 0.2 dB 1 MHz to 5 MHz: +0.2, -0.5 dB 5 MHz to 10 MHz: +0.2, -1.0 dB 10 MHz to 20 MHz: +0.3, -1.5 dB 20 MHz to 50 MHz: +1.0, -3.0 dB</p> <p>\square Up to 1 MHz: ± 0.3 dB \sphericalangle Up to 1 MHz: ± 0.3 dB \sphericalangle, \sphericalangle Up to 1 MHz: ± 0.5 dB</p>
Spectrum purity	<p>Continuous oscillation, External AM off, 50 Ω load, DC offset 0 V, amplitude setting 10 $V_{p-p}/50 \Omega$,</p> <p>10 Hz to 100 kHz: 10 Hz – 100 kHz: 0.3 % and below (bandwidth: 500 kHz) Harmonic spectrum 100 kHz to 1 MHz: -47 dBc and below 1 MHz to 50 MHz: -35 dBc and below</p> <p>Spurious output Up to 50 MHz: -30 dBc and below</p>
Square waveform characteristics	<p>Continuous oscillation, External AM off, 50 Ω load, DC offset 0 V, amplitude setting 10 $V_{p-p}/50 \Omega$</p> <p>Overshoot 5 % and below</p>
Rise time/fall time	7 ns to 1 ms
Range	3 digits
Resolution	
Duty	<p>Continuous oscillation, External AM off, 50 Ω load, DC offset 0 V, amplitude setting 10 $V_{p-p}/50 \Omega$</p> <p>\square (50 % fixed duty) Up to 1 MHz, accuracy of $\pm 1\%$ of the period 1 MHz to 10 MHz, accuracy of $\pm 5\%$ of the period 10 MHz to 50 MHz, accuracy of $\pm 20\%$ of the period</p> <p>\square (duty variable) Up to 100 MHz, accuracy of $\pm 1\%$ of the period Jitter: 7ns-p and below</p>

8.2 Output voltage

● Output voltage (FUNCTION OUT)

Output range	10 V range / 1V range fixed, or automatic switchable
Amplitude	
Range	10 V range : 0 mVp-p to 20.000 Vp-p/open 1 V range : 0.0 mVp-p to 2.0000 Vp-p/open
Resolution	10 V range : 1 mVp-p/open 1V range : 0.1 mVp-p/open
Accuracy	Continuous oscillation, external AM off,  , 1 kHz, rms value measured 10 V range : ± (1 % of amplitude setting [Vp-p] + 0.05 Vp-p)/open 1 V range : ± (1 % of amplitude setting [Vp-p] + 0.01 Vp-p)/open
DC offset	
Range	10 V range : ±10.000 V/open 1 V range : ±1.0000 V/open
Resolution	10 V range : 1 mV/open 1 V range : 0.1 mV/open
Accuracy	10 V range : ± (0.5% of DC offset setting [V] + 0.1 V)/open 1 V range : ± (0.5% of DC offset setting [V] + 0.01 V)/open When DC voltage is generated for both cases
Amplitude and DC offset limiting	If output voltage exceeds the following value, the OVER light blinks and the output may be clipped. 10 V range : 11 V/open 1 V range : 1.1 V/open
Output impedance	50 Ω, unbalanced
Load impedance	45 Ω and more, nominal
Output connector	Front panel, BNC receptacle (FUNCTION OUT)
Others	Output voltage can be set with high and low level buttons.

● SYNC OUT Output voltage (SYNC OUT)





Output voltage	0/+5V (open)
Output waveform	
Rise/fall time	2.5 ns
Output impedance	50 Ω, unbalanced
Load impedance	45 Ω and more
Output connector	Front panel BNC receptacle (SYNC OUT)

8.3 Other functions

● Burst

Oscillation modes	Burst, gate, trigger and trig'd gate (Trig'd gate: gate on/off at each trigger)
Mark wave number	0.5 to 500000.0, 0.5 wave unit (The mark wave number is the oscillation wave number at the time of burst and trigger).
Space wave number	0.5 to 500000.0, 0.5 wave unit (Space wave number is the stop wave number at the time of burst).
Phase	Phase from oscillation stop to oscillation start
Range	-1800.000° to +1800.000°
Resolution	0.001°
Trigger source	Selectable internal trigger oscillator or external trigger input. Trigger can be applied from the panel keys or via remote control (GPIB or USB). The external trigger of CH1 can also be selected as the CH2 trigger source.
External trigger	
Polarity	Trigger: Rising or falling edge selectable Gate: Positive or negative logic selectable. Trig'd gate: Rising or falling edge selectable
Input level	High level $\geq +3.9$ V, low level $\leq +1.6$ V
Minimum pulse width	50 ns
Input impedance	At 10 k Ω , pull up to +5 V.
Input connector	Front panel BNC receptacle (TRIG/SWEEP IN)
Internal trigger oscillator	
Range	1 μ s to 100.0 s
Resolution	4 digits at 1 ms and more, 1 μ s at less than 1 ms.
Trigger delay	
Range	0.3 μ s to 100.00 s
Resolution	5 digits at 1 ms and more, 0.1 μ s at less than 1 ms.
Oscillation mode	Effective with trigger.
Trigger jitter	Less than 50 ns
Oscillation stop level	On and off settable Off: stops at set phase. On: stops at set stop level.
Range	-100.0 % (maximum negative output) to +100.0 % (maximum positive output),
Resolution	0.01 %

● Sweep

Sweep items	Frequency, phase, amplitude, DC offset, duty ( variable duty)
Setting items	Sweep start/stop or sweep center/span, sweep marker (replaces center), sweep start state, sweep stop state
Sweep functions	Continuous / single / gated sweep LIN/LOG (LOG for frequency/amplitude)  /  /  / 
Sweeping time	
Range	1 ms to 10000.000 s (during 2 channel independent, sweep or modulation of only one of the channels) 2 ms to 10000.00 s (other times)
Resolution	1 ms
Sweep trigger	Indicates start of single / gated sweep.
Sweep trigger period	100 ms and more.
Trigger source	Internal trigger oscillator or external trigger input. Also, applicable from panel keys and via remote control (GPIB or USB)
External trigger	
Polarity	Trigger: rise/fall.
Input connector	Front panel, BNC receptacle (TRIG/SWEEP IN)
Minimum pulse width	200 ns
Trigger delay	2 ms
Internal trigger oscillator period	
Range	1 μ s to 100.0 s
Resolution	4 digits at 1 ms and more, 1 μ s at less than 1 ms.
Oscillation stop level	On/off setting effective during gated sweep. Off: stop at set phase. On: stop at set stop level.
Range	-100.0 % (maximum negative output) to +100.0 % (maximum positive output)
Resolution	0.01 %

● Sweep input/output

Sweep trigger input	
Input level	High level $\geq +3.9$ V, low level $\leq +1.6$ V
Signal characteristic	Single/gated sweep start at rising or falling edge (selectable)
Minimum pulse width	200 ns.
Input impedance	At 10 k Ω , pulling up to +5 V
Input connector	Front panel, BNC receptacle (TRIG/SWEEP IN)
Synchronous sweep output	
Output level	0/+5 V (open)
Signal characteristics	Low level: sweeping from start to stop High level: Other times (If  sweep, high level for about 0.2 ms to 0.5 ms directly before quick change from stop to start.)
Output impedance	50 Ω , unbalanced
Load impedance	45 Ω and more
Output connector	Front panel, BNC receptacle (SYNC OUT) Combined use with SYNC OUT
Sweep stop/restart input	
Input level	High level $\geq +3.9$ V, low level $\leq +1.6$ V
Signal characteristics	Low level: Stop sweep when sweep in progress High level: Release the stop
Input impedance	Pulled up to +5 V with 10 k Ω
Input connector	Rear panel BNC receptacle (SWEEP PAUSE IN)
Sweep marker output	
Output level	0/+5 V (open)
Signal characteristics	Low level: Except when marker during sweep High level: When marker during sweep
Output impedance	30 Ω , unbalanced
Load impedance	1 k Ω or more
Output connector	Rear panel BNC receptacle (SWEEP Z-MARKER OUT)
Sweep X-DRIVE output	
Output level	0 V to +5 V (open)
Signal characteristics	0 V \rightarrow +5 V: Sweep value is rising +5 V \rightarrow 0 V: Sweep value is falling
Output impedance	1 k Ω , unbalanced
Load impedance	10 k Ω or more
Output connector	Rear panel BNC receptacle (SWEEP X-DRIVE OUT)

● Internal modulation functions

Modulation items	FM (FSK), PM (PSK), AM, DC offset modulation, PWM (□ variable duty)
Internal modulation frequency	
Range	0.1 mHz to 500.00 Hz (2 channel independent, sweep and modulation of only one channel) 0.1 mHz to 250.00 Hz (other times)
Resolution	5 digits at 1 Hz and more, 0.1 mHz at less than 1 Hz.
Internal modulation waveform	~ , ^ , □ , / , \

● External modulation function

Modulation item	AM, DSB-SC AM, on/off selection
External modulation frequency	DC - 10 MHz
External AM depth	-3 V input: -100% -1 V input: 0% 0 V input: 50% +1 V input: Setup amplitude
Input voltage range	-3 V to +1 V
Input impedance	50 Ω
Input connector	Rear panel BNC receptacle (EXT AM IN)

● External add function

External add	Function that adds an external signal to the FUNCTION OUT signal on/off selection
External add frequency	DC to 10 MHz
External add gain	Unloaded 10 V range: × 2 1 V range: × 0.2
Input voltage range	±5 V
Input impedance	50 Ω
Input connector	Rear panel BNC receptacle (EXT ADD IN)

● Channel operation

Channel modes	2-channel independent/2 phase (same frequency)/fixed frequency ratio/fixed frequency difference/differential output (same frequency, amplitude, DC offset, reverse phase)
Phase	Common with start phase during burst, gate, trigger, triggered gate and gated sweep.
Range	-1800.000° to +1800.000° (not effective for the differential output).
Resolution	0.001°
Time difference between channels	Less than ±25 ns during continuous oscillation, 50 Ω load, DC offset 0 V, amplitude setting 10 Vp-p/50 Ω, same waveform, 2-phase channel mode.
Frequency difference setting	
Range	0.00 μHz to 49.99999999999999 MHz (Valid in fixed frequency difference mode. The frequency difference between CH2 and CH1 is set.)
Resolution	0.01 μHz
Fixed frequency ratio setting	The CH1 and CH2 frequency ratio is set in the form N:M.
Range	N and M are respectively 0000001 to 9999999.
Resolution	1 Frequency resolutions are $N \times 0.01 \mu\text{Hz}$ and $M \times 0.01 \mu\text{Hz}$ respectively. (Valid in fixed frequency ratio mode.)
Phase synchronization	Manual or remote control Automatic when changing channel mode. (Function restarts all channel output waveforms from the set phase. Used to clarify phase relationship. Effective for all connected channels during synchronous operation.)
Simultaneous setting	Function for making a setting for two channels simultaneously
Others	Copies the CH2 setting to CH1 Copies the CH1 setting to CH2

● Setting initialization

Functions	Initializes nearly all setting contents. Initialization settings,  "3.3 Basic operation", cf.
-----------	---

● User-unit function

Function	Converts to desired units for set up and display.
Setting items	Frequency, period, amplitude, DC offset, phase and duty.
Coefficient setting	Select either [(internal set up) + n] × m, or [log ₁₀ (internal set up) + n] × m; then, set the value of n and m. Frequency and period: 15 digits mantissa and 1 digit exponent (both m and n) Amplitude, DC offset and duty.: 6 digits mantissa and 1 digit exponent (m and n) Phase: 7 digits mantissa and 1 digit exponent (m and n)
Unit character string	Alphanumeric and 34 symbols Set up and display up to 4 characters.

● Load function

Function	Set up and display at actual voltage for an arbitrary load Conversion formula: (Output voltage at load) = (Output voltage at no-load) × $\frac{(\text{Load impedance})}{(\text{Output impedance} : 50 \Omega) + (\text{Load impedance})}$
Load impedance setting	
Range	45 Ω to 999 Ω
Resolution	1 Ω

● Output on/off

Function	Output switched on/off
Output off state	FUNCTION OUT: open. SYNC OUT: TTL three states high impedance.
Power on state	Selectable return to the state when the power supply was switched off or output on/off state.

● Setting memory, Backup

Setting memory	Nearly all setting items can be stored and recalled. 10 sets from 0 to 9
Backup	Battery back up for nearly all settings prior to power off.
Backup period	Three years and more under normal temperature.
Battery	Lithium cell
Operation when battery depleted	Error at power on and settings are initialized. Output voltage in inadequate. Battery needs replacement (fee charged)

8.4 Initialized settings

- **Initialized settings**

Initialization settings,  “3.3 Basic operation(■ Initialization table)”, cf.

- **Error from backup battery depletion**

In addition to setting initialization, following are set:

Output on/off	Off
Output on/off in turning on	LAST-STATE (condition just before power off)
Setting memory	ALL NOT STORED
Setting memory comment	" " (blank)
User unit name	USER
User unit computation formula	(h+n)*m
User unit coefficient	1
User unit offset	0
Arbitrary waveform selection	0:ARB_00
Arbitrary waveform name	ARB_00 (00 to 11)
Arbitrary data size	8 K
Arbitrary waveform data	All 0
Remote control interface	GPIB
GPIB address	2
GPIB delimiter	CR+LF
USB ID	2

8.5 Remote control

● GPIB interface

GPIB function	SH1 All source handshake functions AH1 All acceptor handshake functions T6 Basic talker serial poll, talker release by MLA L4 Basic listener, listener release by MTA SR1 All service request functions RL1 All remote/local functions PP0 No parallel poll functions DC1 All device clear functions DT1 All device trigger functions C0 No controller functions
Use code	ISO 7 bit codes (ASCII code)
Address	0 to 30 (set from panel)
Output driver	DIO1-8, NDAC, NRFD and SRQ : Open collector DAV and EOI : 3-state
GPIB parameters	GPIB address (0 to 30), delimiter in transmission (CR/LF+EOI, CR+EOI, LF+EOI)
Remote release	Remote condition can be canceled by LOCAL key. (Except for Local Lockout)
Connector	Rear panel, IEEE 488 (24-pins) connector

● USB interface

USB1.1 full speed

8.6 Options

- **1991 synchronized operation option**

Function	Synchronizes operation of multiple WAVE FACTORY series Note machines. The 1991 is needed on all machines that participate in synchronized operation.
Time difference	When the phase is synchronized after setting of the same waveform and frequency for continuous oscillation, external AM off, 50- Ω load, 0 V DC offset, and amplitude setting of 10 V _{p-p} /50 Ω Time difference between units: ± 25 ns plus maximum of 10 ns for each unit
Cabling	The cable used to connect multiple WAVE FACTORY series Note machines is sold separately (1994 synchronized-operation cable).

- **1994 synchronized-operation cable**

Cable for the 1991 synchronized operation option to connect multiple WAVE FACTORY series Note machines. For connection of n WAVE FACTORY series Note machines, (n-1) 1994 synchronized-operation cables are needed.

Note : 1945, 1946, 1956, WF1945, WF1946, WF1956, WF1965, and WF1966 from NF Corporation

8.7 General items

- **Input/output ground**

The signal grounds of FUNCTION OUT, SYNC OUT, EXT AM IN, and EXT ADD IN are floated from the chassis. The input/output grounds of these signals on one channel are common.

Signal ground dielectric strength: ± 42 V_{peak}, 30 V_{rms} (DC - 20 kHz, continuous)

The input/output grounds of all other signals are connected to the chassis.

- **Power supply**

Power supply voltage range AC100 V/115 V/230 V

Power supply frequency range 50/60 Hz \pm 2 Hz

Power supply fuse Time lag 2 A (100 V/115 V) or time lag 1 A (230 V)

250 V, $\phi 5.2 \times 20$ mm

Consumption electric power 100 VA and less

Overvoltage category II

- **Cooling**

Forced-air cooling, rear exhaust

- **Setup condition**

Horizontal (Within 10°)

- **Environmental conditions**

Ambient temperature and humidity range

Performance guarantee +5 to +35° C, 5 to 85 %RH

(no condensation at an absolute humidity of 1 to 25 g/m³)

Storage time -10 to +50° C, 5 to 95 %RH

(no condensation at an absolute humidity of 1 to 29 g/m³)

Pollution degree 2

- **Insulation resistance**

20 M Ω and more (DC 500 V, power input lines versus chassis).

- **Withstand voltage**

AC 1500 V (power input lines versus chassis).

- **Dimensions**

216(W) \times 132.5(H) \times 290(D) mm (Excluding protrusions).

- **Mass**

Mainframe excluding attachments, options, etc.

Approx. 4.7 kg,

- **Safety**

EN 61010-1: 2001

- **EMC**

EN 61326: 1997/A1: 1998/A2: 2001

However, the performance criteria for the following standards are as follows:

EN61000-4-2(1995):C

EN61000-4-4(1995), EN61000-4-5(1995), EN61000-4-11(1994):B

External drawing

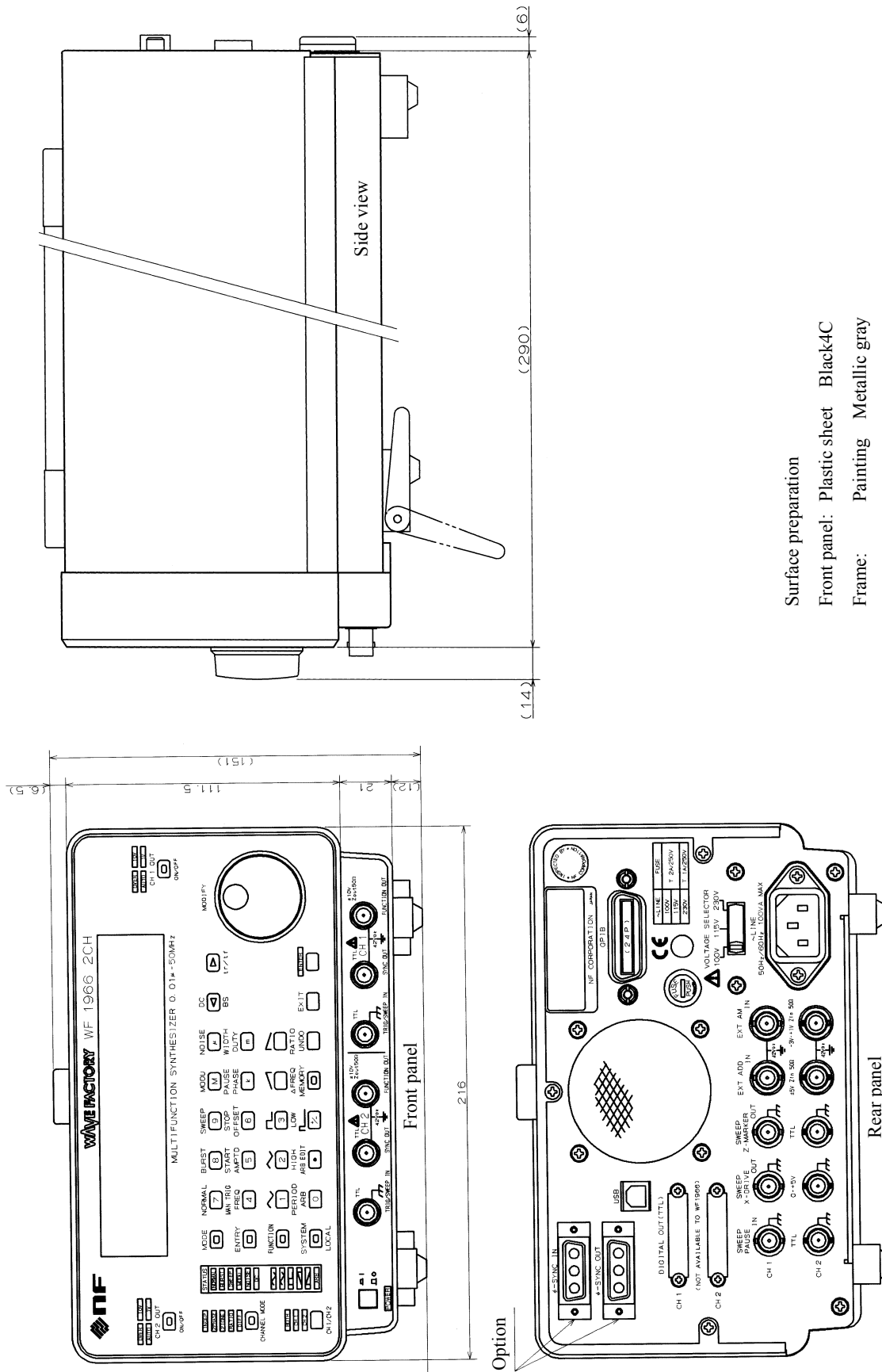

Surface preparation
 Front panel: Plastic sheet Black4C
 Frame: Painting Metallic gray
 Cover: Polyvinyl chloride metal laminated plate Metallic gray

Index

Front and rear panel indications (alphabetical order).

- Δ FREQ 5-28
- 2PHASE 3-17, 3-18, 3-19, 3-20, 3-21
- 2TONE 3-17, 3-19, 3-20, 3-21, 5-28
- AMPTD 3-25, 5-8, 5-10, 5-22
- ARB 4-56, 5-10
- ARB EDIT 4-56
- BOTH 3-21, 4-9, 4-12, 4-15, 4-22, 4-43
- BS 3-24, 3-25, 3-26, 3-27, 3-28
- BURST 3-8, 3-22, 4-2
- CH 1/CH 2 3-21
- CH 1,CH 2 OUT 3-3, 3-29
- CHANNEL MODE 3-17, 5-28
- COPY 4-58
- DC 3-8, 3-22, 3-23, 3-24, 3-25, 3-26
- DIFF 3-17, 3-19, 3-20, 3-21, 3-29
- DUTY 3-23, 5-3, 5-6
- EDIT 4-57
- ENTER 3-3, 3-14, 3-26, 3-27, 5-9
- ENTRY 3-24, 3-25, 3-26, 3-27, 3-28, 5-2, 5-3, 5-6, 5-7
- EXIT 3-3, 3-14, 3-24, 3-25, 3-26, 3-27, 3-28
- EXT ADD IN 3-11, 5-18
- EXT AM IN 3-12, 5-19
- FREQ 3-24, 5-3, 5-6
- FUNCTION 3-23, 4-56
- FUNCTION OUT 3-5
- HIGH 5-5
- INDEP 3-17, 3-19, 3-20, 3-21, 5-26
- k 4-59, 5-9
- LOCAL GPIB separate volume
- LOW 5-7
- m 4-58, 5-9
- M 5-9
- MAN TRIG 4-8, 4-12, 4-15, 5-25
- MEMORY 5-15
- MODE 3-22, 4-2, 4-16, 4-41
- MODU 3-8, 3-22, 3-23, 4-41
- NOISE 3-8, 3-22, 3-23, 3-24, 5-10
- NORMAL 3-22, 5-27
- OFFSET 3-26, 5-8, 5-22
- OVER 3-5
- PAUSE 4-20, 4-25, 4-32
- PERIOD 5-2, 5-3, 5-6
- PHASE 3-27, 5-27
- RATIO 3-17, 3-19, 3-20, 3-21, 5-29
- START 4-18, 4-19, 4-24, 4-25, 4-31, 4-43, 4-46, 4-49, 4-52, 4-55
- STOP 4-18, 4-19, 4-20, 4-21, 4-24, 4-25, 4-26, 4-32, 4-43, 4-46, 4-49, 4-52, 4-55
- SWEEP 3-8, 3-22, 3-23, 4-16
- SWEEP PAUSE IN 3-10, 4-20, 4-25, 4-32
- SWEEP X-DRIVE OUT 3-10, 4-39
- SWEEP Z-MARKER OUT 3-11, 4-34, 4-39
- SYNC OUT 3-6, 4-39
- SYSTEM 3-14, 5-11, 5-18, 5-19, 5-20, 5-21, 5-22, 5-26, 5-27
- TRIG/SWEEP IN 3-9, 4-8, 4-11, 4-14, 4-20, 4-32, 5-25
- tr/ta 3-28
- UNDO 5-23
- WIDTH 5-3, 5-6
- ϕ -SYNC IN, OUT 3-12, 5-26
- μ 5-9

WARRANTY

NF Corporation certifies that this instrument was thoroughly tested and inspected and found to meet its published specifications when it was shipped from our factory.

All **NF** products are warranted against defects in materials and workmanship for a period of one year from the date of shipment. During the warranty period of, **NF** will, at its option, either will repair the defective product without any charge for the parts and labor, or either repair or replace products which prove to be defective. For repair service under warranty, the product must be returned to a service center designated by **NF**. Purchaser shall prepay all shipping cost, duties, and taxes for the product to **NF** from another country, and **NF** shall pay shipping charge to returned the product to purchaser.

This warranty shall not apply to any defect, failure or damage caused by improper use, improper or inadequate maintenance and care or modified by purchaser or personnel other than **NF** representatives.

NF Corporation

WABUN: (≈510060-7)

If there are any misplaced or missing pages, we will replace the manual. Contact the sales representative.

NOTES

- Reproduction of the contents of this manual is forbidden by applicable laws.
- The contents of this manual may be revised without notice.
- Information provided in this manual is intended to be accurate and reliable. However, we assume no responsibility for any damage regarding the contents of this manual.
- We assume no responsibility for influences resulting from the operations in this manual.

Copyright 2005, **NF Corporation**

WF1966 MULTIFUNCTION SYNTHESIZER Instruction Manual

NF Corporation

6-3-20 Tsunashima Higashi, Kohoku-ku, Yokohama

223-8508, JAPAN

Phone +81-45-545-8111 Fax +81-45-545-8191

