



MAIN FRAME

MS-523 / MS-525

INSTRUCTION MANUAL

D:59503-1

MS-523/525

MAINFRAME

[INSTRUCTION MANUAL]

Table of Contents

	Page	
1.	GENERAL DESCRIPTION	1-1
1.1	MS-500 Series	1-1
1.2	MS-523/525 Outline	1-1
1.3	MS-523/525 Features	1-2
1.4	Specifications	1-3
2.	PREPARATIONS	2-1
2.1	Unpacking and Repacking	2-1
2.2	Preliminary Inspection	2-1
2.3	Installation Location	2-2
2.4	Plug-In Unit Insertion	2-3
2.5	Plug-In Unit Locations	2-4
2.6	Power Supplies and Grounding	2-5
2.7	Rack Mounting (MS-525 Only)	2-10
3.	OPERATION	3-1
3.1	Names and Operation of Mainframe Parts	3-1
3.2	Initial Setup	3-4
3.3	Centralized Output Connector	3-5
4.	PRINCIPLE OF OPERATION	4-1
4.1	Outline	4-1
4.2	MS-523 Block Diagram	4-1
4.3	MS-525 Block Diagram	4-2
4.4	Connections to the Individual Plug-In Units	4-4
5.	MAINTENANCE	5-1
5.1	Outline	5-1
5.2	Operational Checks	5-1
5.3	Calibration of Plug-In Unit Power Supplies	5-11

Supplementary Figures and Tables

		Page
Fig. 1-1	MS-523 Outer Dimensions	1-6
Fig. 1-2	MS-525 Outer Dimensions	1-7
Fig. 2-1	Plug-in unit location (MS-523)	2-4
Fig. 2-2	Plug-in unit location (MS-525)	2-5
Fig. 2-3	Line filter circuit	2-6
Fig. 2-4	Using a 100VAC power source (MS-523) ..	2-7
Fig. 2-5	Using a 12VDC power source (MS-523) ..	2-8
Fig. 2-6	Fuse replacement	2-9
Fig. 2-7	Rack mount fixture mounting	2-11
Fig. 2-8	Rack mounting (1)	2-11
Fig. 2-9	Rack mounting (2)	2-12
Fig. 3-1	MS-523 Front/rear panels	3-3
Fig. 3-2	MS-525 Front/rear panels	3-3
Fig. 3-3	MS-523 Centralized output connector ..	3-5
Fig. 3-4	MS-525 Centralized output connector ..	3-5
Fig. 4-1	MS-523 Block diagram	4-3
Fig. 4-2	MS-525 Block diagram	4-3
Fig. 4-3	Plug-in unit to mainframe interconnections	4-4
Fig. 5-1	Output voltage check pin positions ...	5-3
Fig. 5-2	MS-525 Power supply bus configuration	5-4
Fig. 5-3	Control bus lines	5-6
Fig. 5-4	Multiplexer bus line	5-7
Fig. 5-5	Cascade line connections	5-8
Fig. 5-6	MS-523 Centralized output connector ..	5-9
Fig. 5-7	MS-525 Centralized output connector ..	5-9
Fig. 5-8	Centralized output connector wiring (MS-523)	5-10
Fig. 5-9	Centralized output connector wiring (MS-525)	5-10
Fig. 5-10	Rear cover removal (MS-525)	5-11
Fig. 5-11	+5V Output adjustment (MS-525)	5-11
Fig. 5-12	Side plate removal (MS-525)	5-12
Fig. 5-13	+24V and +5V Adjustment (MS-523)	5-12
Table 2-1	Mainframe Configurations	2-2
Table 2-2	MS-525 Power Supply Voltage Settings and Fuse Ratings	2-9
Table 5-1	Output Voltages	5-3
Table 5-2	Slot Number Presetting Codes	5-7

1. GENERAL DESCRIPTION

1.1 MS-500 Series

The MS-500 Series measurement system is designed for use in automated measurement applications and consists of a multi-channel system configured of ultra-thin plug-in units housed in a standard rack. Up to 16 channels can be accommodated, and GP-IB control is also possible.

The system consists of a mainframe which includes a power supply, a control unit, and various combinations of filters, amplifiers, and other functional plug-in units.

Two types of mainframes are available, the MS-523 and MS-525. In addition to the control units, these two models can accommodate a maximum of 8 and 16 channels respectively, providing power for the functional plug-in units used for these channels.

Two types of control units are available. The P-41 Control Unit and P-42 GP-IB Unit.

When using the P-41 Control Unit, one group of functional plug-in units can be controlled simultaneously using the MS-523 and two groups can be controlled simultaneously using the MS-525.

The P-42 GP-IB Unit is used to enable GP-IB control of the system, with the outputs of the various functional plug-in units being transmitted after A/D conversion over the GP-IB bus. It also provides such functions as control of the functional plug-in unit analog multiplexer.

Connections between functional plug-in units may be made, including such connections as amplifier-to-filter and filter-to-amplifier by means of cascade buttons at the rear panel of units provided with such features, this capability enabling such connections without the requirement of making external interconnections.

1.2 MS-523/525 Outline

The MS-5223/525 Mainframe was designed as the basis for the multi-channel MS-500 Series measurement system, a system intended for use in automated measurement applications. It can accommodate plug-in units and provides power for these units.

The MS-523 provides eight functional plug-in slots and one control slot. To enable use aboard vehicles, its switchable power input can accept

both 100VAC and 12VDC power supply inputs.

The MS-525 has 16 slots for functional plug-in units, one control slot, and is mounted in a standard JIS 480mm wide rack. The AC-only power supply accommodates line voltages of 100, 120, 220, and 240VAC.

1.3 MS-523/525 Features

1.3.1 High-Density, Multi-Channel Capability

Using ultra-thin plug-in units, a single mainframe can accommodate many channels. The MS-523 and MS-525 mainframes can accommodate any number of channels up to 8 and 16 respectively.

1.3.2 Rear Panel Centralized Outputs Provided as Standard

A rear panel grouping of all channel outputs is provided as a standard feature to facilitate system interconnections.

1.3.3 MS-500 Series Standard Bus Line

To enable simultaneous control of a number of plug-in units, the MS-500 Series standard bus line may be used by either the MS-523 or MS-525 mainframes.

1.3.4 Universal Power Supply

To enable use aboard vehicles, the MS-523 is powerable from a 12VDC source in addition to 100VAC power, and the MS-525 is powerable from AC line sources of 100, 120, 220, and 240V.

1.4 Specifications

1.4.1 Number of Slots

Model	MS-523	MS-525
Type of Slot		
Functional plug-in	8	16
Control	1	1

1.4.2 Centralized Outputs

Model	MS-523	MS-525
Connector type	24-Pin multi-connector	50-pin multi-connector
Functional plug-in slot outputs	8	16
Multiplexer output*	1	1

* Only when using the P-42

1.4.3 Voltages Supplied

The mainframe supplies the following voltages.

+24V	+2V -1V
-24V	-2V +1V
+5V	+0.2V

1.4.4 Maximum Current Available From Each Slot

Slot type Voltage	Functional plug-in	Control
+24V	+100mA	+100mA
+5V	+130mA	+1.1A

1.4.5 Power Supply

Model/Mode	MS-523		MS-525
	AC Mode	DC Mode	
Voltage range	100V <u>+10%</u>	11 ~ 15V	100, 120, 220, 240V <u>+10%</u>
Frequency	50/60Hz	DC	50/60Hz
Power consumption*	Approx. 140VA	Approx. 100VA	Approx. 230VA

* These figures are for the case of all slots supplying their maximum respective currents.

1.4.6 Environmental Conditions

Operating temperature and humidity 0 ~ 40°C, 10 ~ 90% RH

Storage temperature and humidity -10 ~ 50°C, 10 ~ 80% RH

1.4.7 Dimensions and Weights

	MS-523	MS-525
Dimensions(mm) *	238.5(W) × 199(H) × 400(D)	429(W) × 199(H) × 400(D)
Weight **	Approx. 6.1kg	Approx. 12.2kg

* Protruding parts not included.

** Mainframe only. Each blank panel weighs 50g/slot.

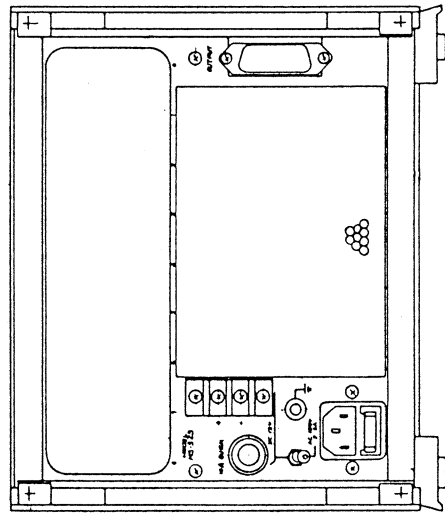
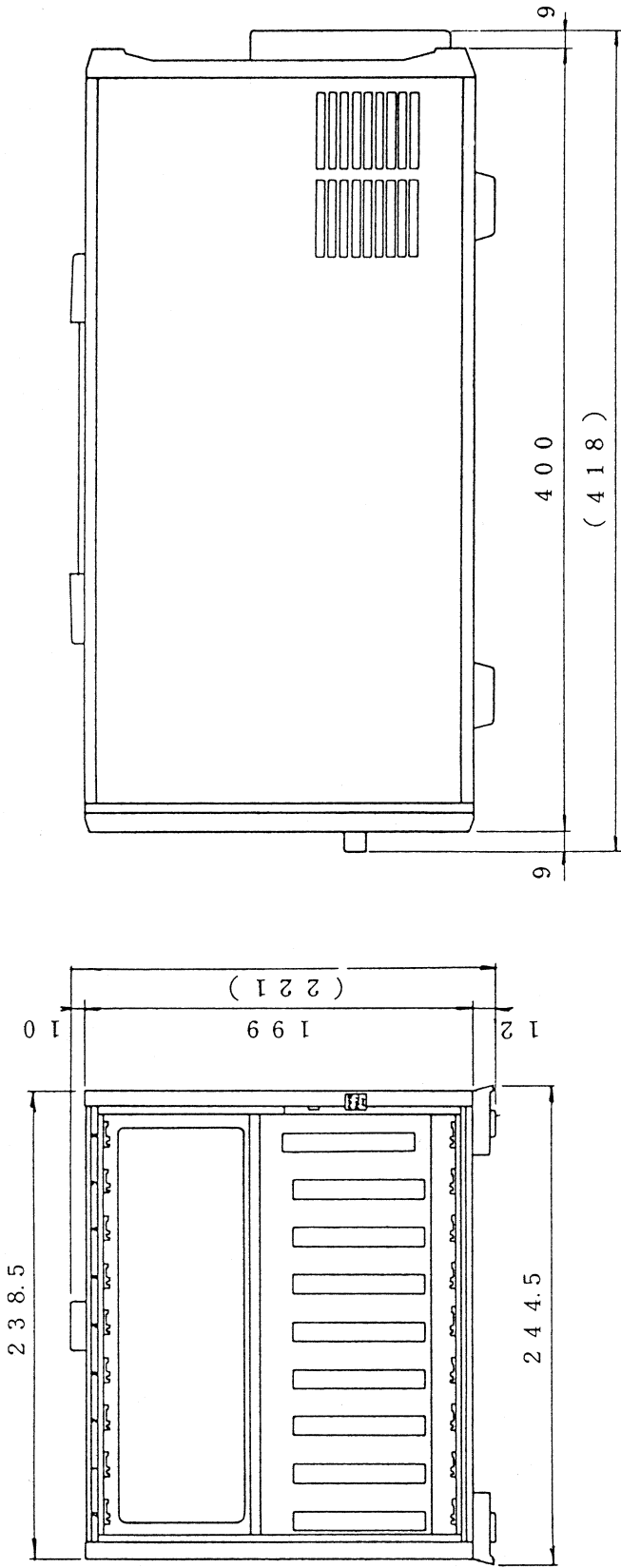

Fig. 1-1 MS-523 Outer Dimensions

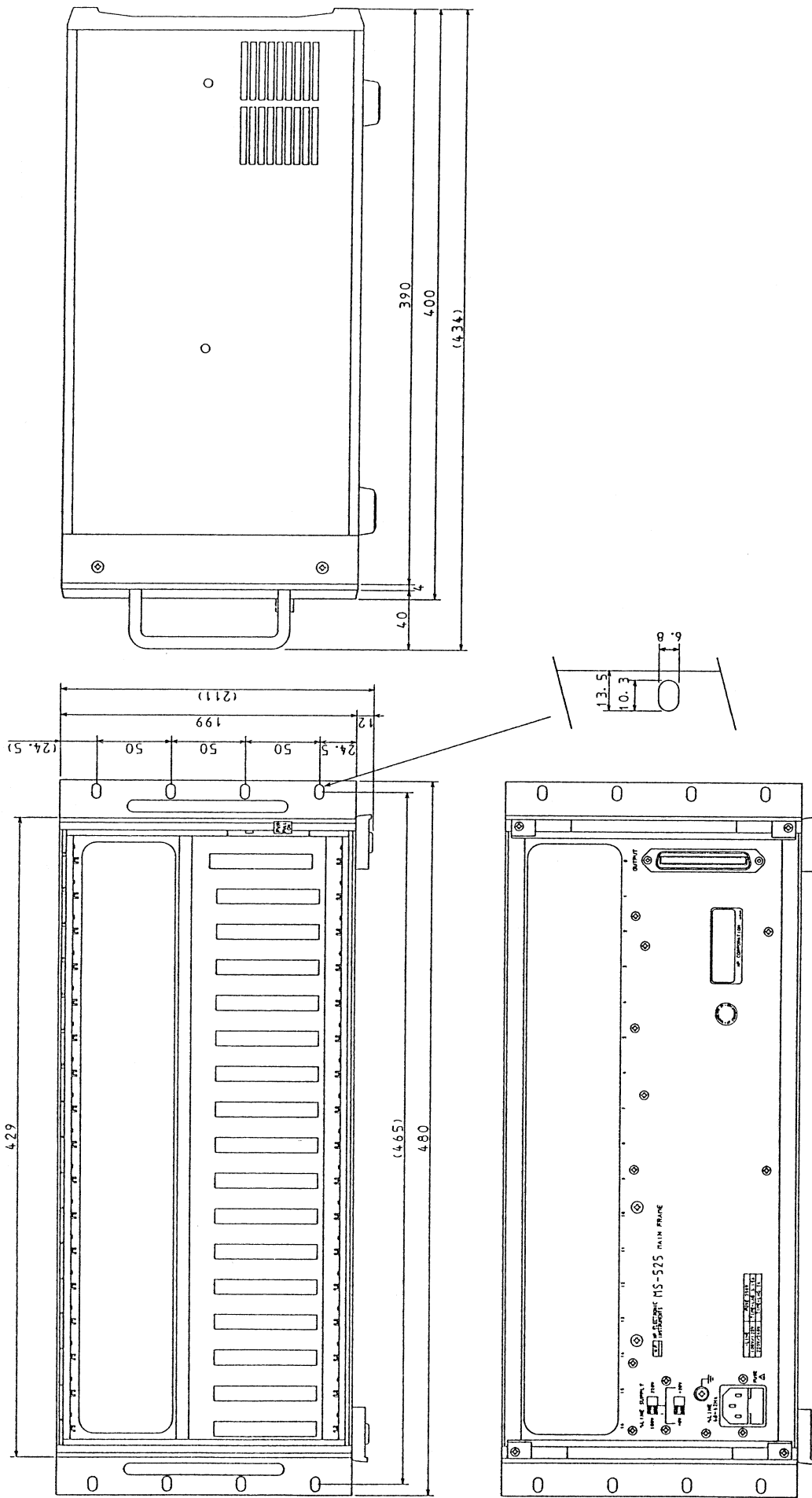

Fig. 1-2 MS-525 Outer Dimensions

2. PREPARATIONS

2.1 Unpacking and Repacking

2.1.1 Unpacking

After unpacking the mainframe, first check that damage has not been caused accidentally during shipping. Sufficient care is taken with the unit before shipping. However, a check should be made of such items as loose controls and that all the required accessories have been included, as listed in Table 2-1 below.

2.1.2 Repacking

When repacking the mainframe for shipping or transport, it should be packed with sufficient polyethylene packing material in a cardboard carton strong enough to withstand the weight of this unit.

2.2 Preliminary Inspection

The standard mainframe configuration consists of the following listed components.

MS-523 Configuration	
Mainframe	1
Instruction Manual	1
Accessories	
24-Pin connector	1
Power cable	1
Spare fuse (2A, located inside holder)	(1)
Spare fuse (10A), fast blow	1

MS-525 Configuration	
Mainframe	1
Instruction manual	1
Accessories	
50-Pin connector	1
Power cable	1
Spare (3A, located inside holder)	(1)

Table 2-1 Mainframe Configurations

2.3 Installation Location

The MS-523/525 Mainframe uses forced air cooling by means of a fan. Air vents are located at both sides and at the top and bottom of the unit, so that the unit must be located at least several centimeters away from objects which would block these vents. A transistor heatsink is located at the rear of the MS-523 and is naturally air cooled. Therefore, the mainframe should not be stood on its rear.

The operating environmental limits for the mainframe are 0 ~ 40°C temperature and 10 ~ 90% RH, while the corresponding storage limits are -10 ~ 50°C and 10 ~ 80% RH. Avoid locations subject to severe changes in ambient temperature,

such as those subjected to direct sunlight, high humidity locations, and locations subject to excessive dust or vibration.

Although the mainframe is provided with a power line filter, use in proximity to pulse-noise sources, strong electric or strong magnetic fields may cause misoperation. Avoid, therefore, such installation locations as much as possible.

2.4 Plug-In Unit Insertion

Plug-in unit insertion is performed by the following prescribed procedure. When inserting plug-ins, care should be taken since the locations for functional plug-in units differ from those assigned to the control unit. Refer to section 2.5 on unit location.

- 2.4.1 Turn to the left and loosen completely the locking screw at the bottom part of the plug-in unit front panel.
- 2.4.2 Hold the unit from the bottom and at the left and right of the front panel.
- 2.4.3 A control unit must be inserted at the rightmost slot, while functional plug-in units may be inserted in any other slot. Insert the unit so that its board fits in the grooves at the top and bottom of its slot.
- 2.4.4 Tighten completely the locking screw at the bottom of the front panel of the plug-in unit to fix the unit in its slot.

CAUTION

- o Plug-in units should always be inserted into the mainframe after the power supply switch has been turned off.
- o Control units may be inserted only at the rightmost slot, while other (functional) plug-in units may be inserted at any other slot.

2.5 Plug-In Unit Locations

2.5.1 MS-523 Plug-In Unit Locations (Refer to Fig. 2-1)

The control units (P-41 or P-42) are inserted at the rightmost (8th) slot, while the functional plug-in units may be inserted in any slot from the 0th to the 7th. Care should be taken as inserting a plug-in unit in a wrong slot can cause damage.

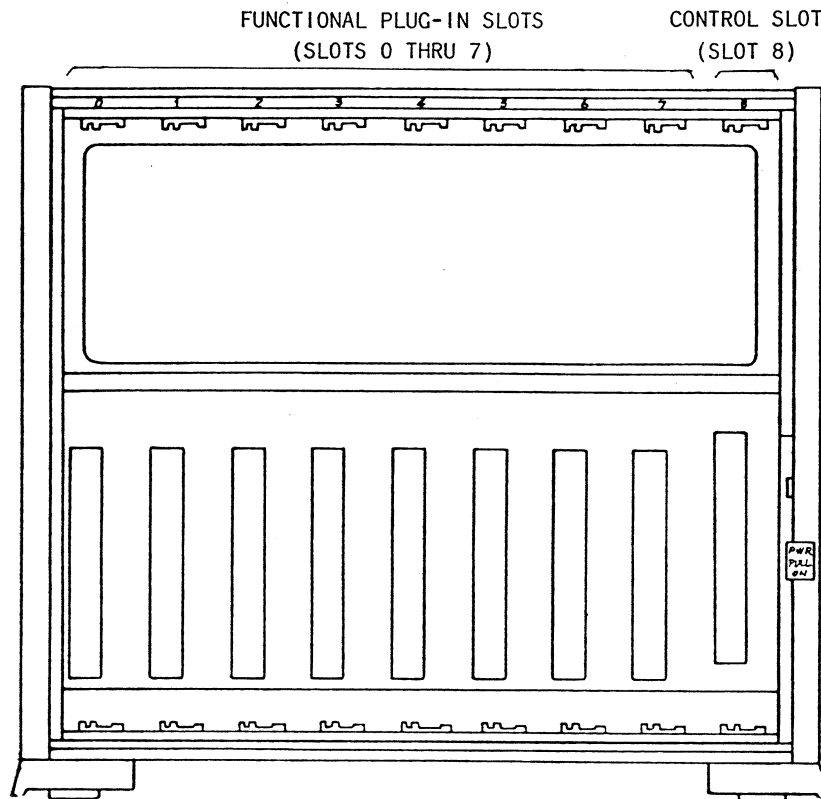

Fig. 2-1 Plug-in unit location (MS-523)

2.5.2 MS-525 Plug-In Unit Locations (Refer to Fig. 2-2)

The control units (P-41 or P-42) are inserted at the rightmost (16th) slot, while the functional plug-in units may be inserted in any slot from the 0th to the 15th. Care should be taken as inserting a plug-in unit in a wrong slot can cause damage.

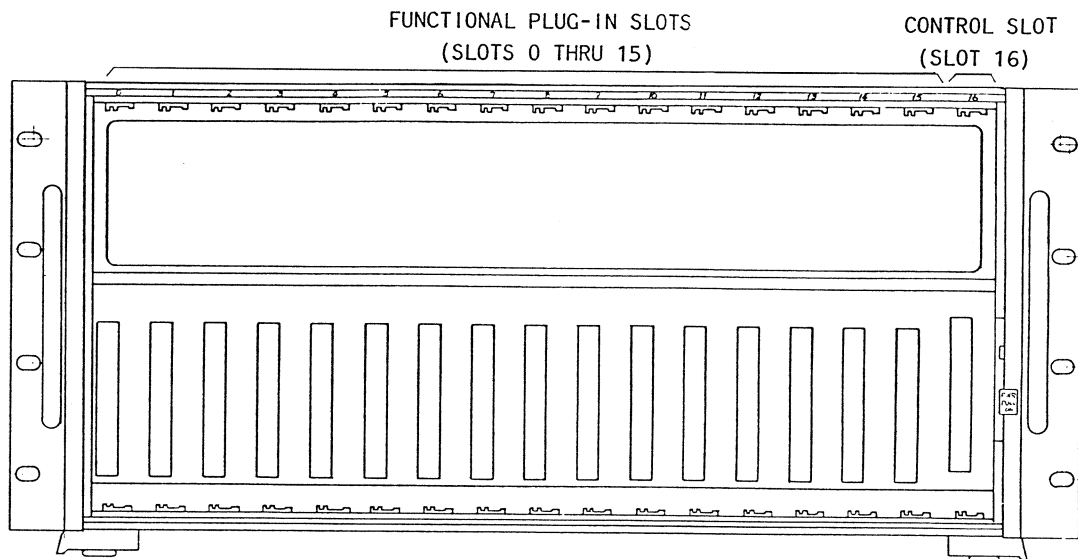

Fig. 2-2 Plug-in unit location (MS-525)

2.6 Power Supplies and Grounding

The MS-523/525 should always be used with a power supply voltage within the specified limits. If this is not observed, not only may the unit be adversely effected, but damage could also result. Always apply voltage within the specified limits after verifying the rear panel switch setting.

The mainframe is provided with a line power filter circuit, as shown in Fig. 2-3. The leakage current at 250V (60Hz) is a maximum of 0.5mArms. Therefore, if the cabinet is not grounded, a danger of shock exists. The cabinet should always be grounded using the grounding terminal. This should be done in accordance with IEC publication 348 (describing safety standards for electronic measurement instruments).

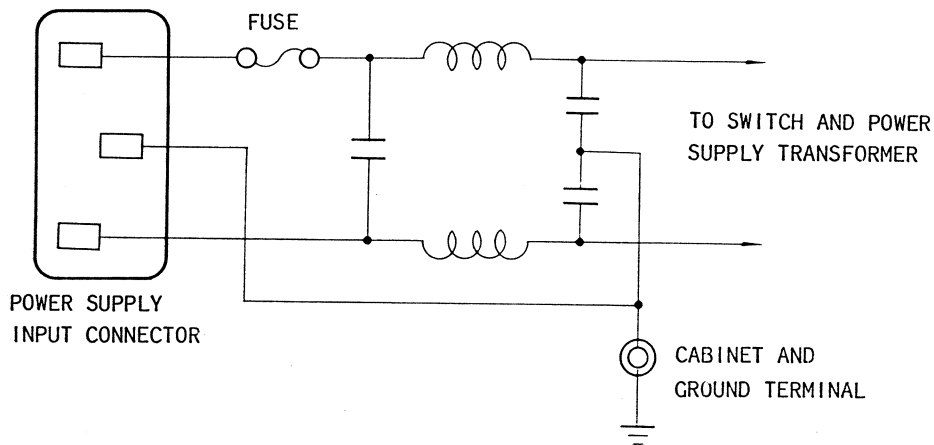

Fig. 2-3 Line filter circuit

The following sections describe the power supply connections for the MS-523 and MS-525.

2.6.1 MS-523 Power Supply Connections

For the MS-523 with its eight functional plug-in slots, a rear panel switch setting and changing of the input location allows a combination of the following two types of power supplies.

AC: 100Vrms $\pm 10\%$, 50/60Hz

DC: 11 ~ 15V

For AC power operation, a normal-blow midget (2A) fuse is located in a holder below the power supply connector. For DC operation, a quick-blow 10A fuse is used.

Before connecting the power supply cable, verify that the power switch of the mainframe is turned off, and verify the setting on the AC/DC switch at the rear panel before applying the

proper voltage. Note that the AC/DC switch is a locking-type switch which must be pulled to change.

When using an AC line power source, use the accessory power cable. A 3-pin power inlet connector is used. A power cable with a 3-pin connector is supplied, the third (central) pin being used for ground connection.

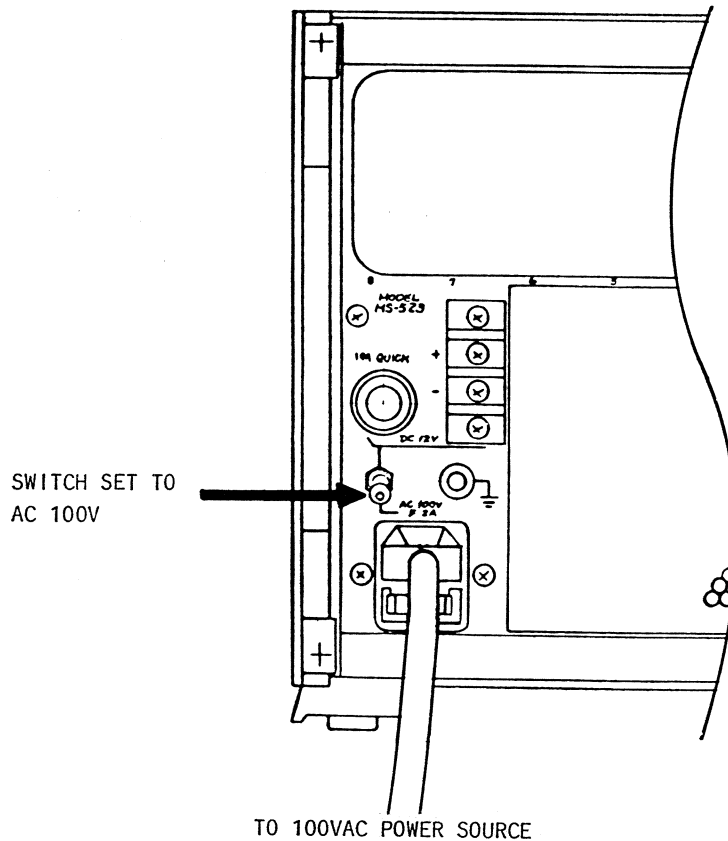

Fig. 2-4 Using a 100VAC power source (MS-523)

When using a DC power supply, since the maximum current required is 7A, a cable of sufficient size should be used to eliminate excessive voltage drop within the cable. The minimum cross-section area should be 1.25mm^2 . This cable is connected to the terminals at the rear panel. (A one meter long cable of cross-section 1.25mm^2 will result in a voltage drop of approximately 0.25V.)

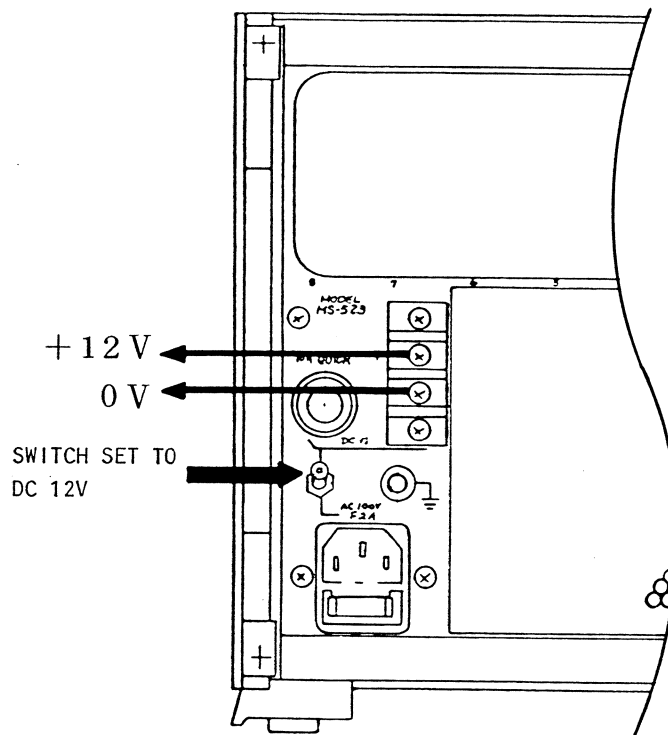

Fig. 2-5 Using a 12VDC power supply (MS-523)

2.6.2 MS-525 Power Supply Connections

The MS-525, with its 16 slots for functional plug-in units, is provided with a rear panel switch to select 100, 120, 220, or 240VAC $\pm 10\%$, 50/60Hz.

Before connecting the power supply, verify that the mainframe power switch is off and that the rear panel switch is set to the proper line voltage. After this verification, connect the line power source using the accessory power cable.

A 3-pin power inlet connector is used. A power cable with a 3-pin connector is supplied, the third (central) pin being used for ground connection.

CAUTION

- o When shipped, the mainframe is set up for 100Vrms operation. Please verify this and change accordingly if required.
- o Never change the power supply voltage setting without first removing the power plug from the AC outlet.

The mainframe AC voltage setting is changed by a combination of two rear panel switches. The resulting ranges and proper fuse capacities are shown in Table 2-2. The fuse is located on a holder below the power supply connector. Fuse replacement, as shown in Fig. 2-6, is done by pulling the holder cover forward using a flat-blade screwdriver. The fuse closest to the cover is a spare fuse stored within the holder.

	100VA	220VA
+0V	90 ~ 110Vrms 3A	198 ~ 242Vrms 2A
+20V	108 ~ 132Vrms 3A	216 ~ 264Vrms 2A

Table 2-2 MS-525 Power Supply Voltage Settings and Fuse Ratings

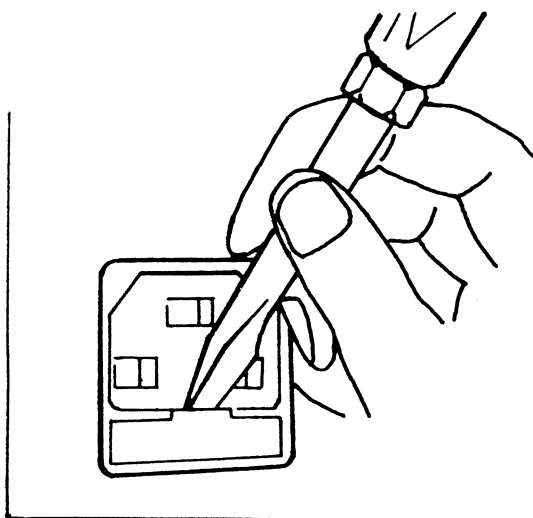

Fig. 2-6 Fuse replacement

2.7 Rack Mounting (MS-525 Only)

The MS-525 Mainframe may be rack mounted in a standard JIS 480mm wide rack using optional guides and rails. The procedure for mounting these guides and rails is described in the sections below. (Refer to Fig. 2-7 thru 2-9.)

Rack Machining

2.7.1 Drill holes in the rack frame as shown in Fig. 2-7.

2.7.2 Mount the two rails to the rack frame using M5 bolts, nuts, and spring washers.

Mainframe Machining

2.7.3 Remove the screws using a phillips screwdriver and mount the rear guard to the cabinet.

2.7.4 Pull the sides and bottom off to the rear.

2.7.5 Mount the guides and reinforcing plates using eight M5 screws.

2.7.6 Unscrew the feet from the bottom of the cabinet.

2.7.7 Insert the sides and bottom plate and remount the rear guard.

Rack Mounting

2.7.8 As shown in Fig. 2-9, position the rails so as to enclose the side plate guides and push the cabinet into the rack.

2.7.9 Using flat and locking washers, mount the mainframe from the front into the rack frame.

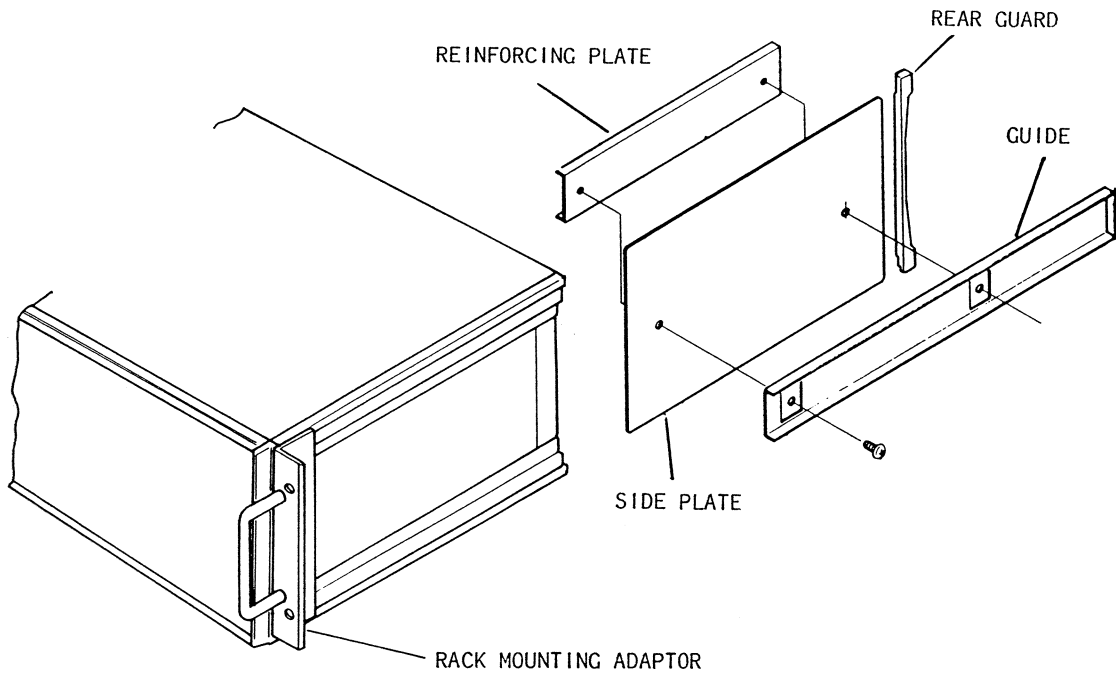

Fig. 2-7 Rack mount fixture mounting

DRILL HOLES IN THE ENTIRE RACK FRAME IN THIS PART OF DIAMETER 5.5mm

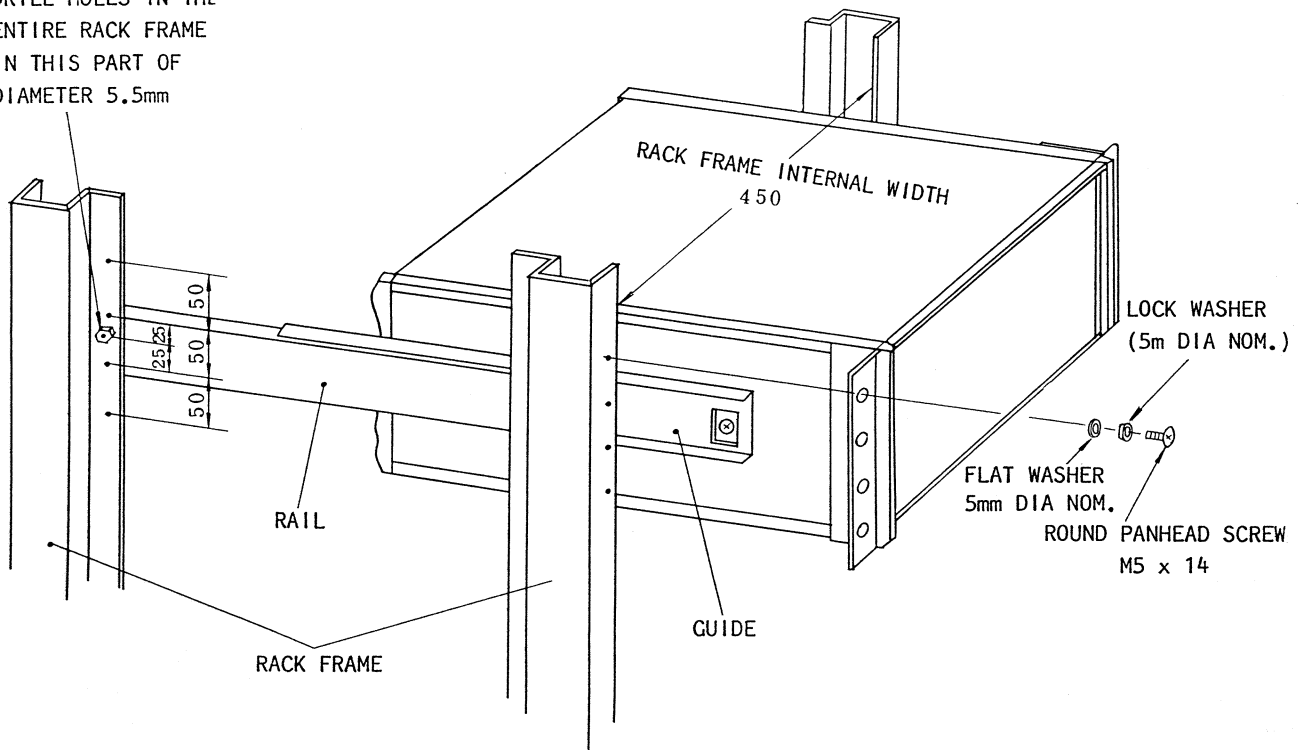

Fig. 2-8 Rack mounting (1)

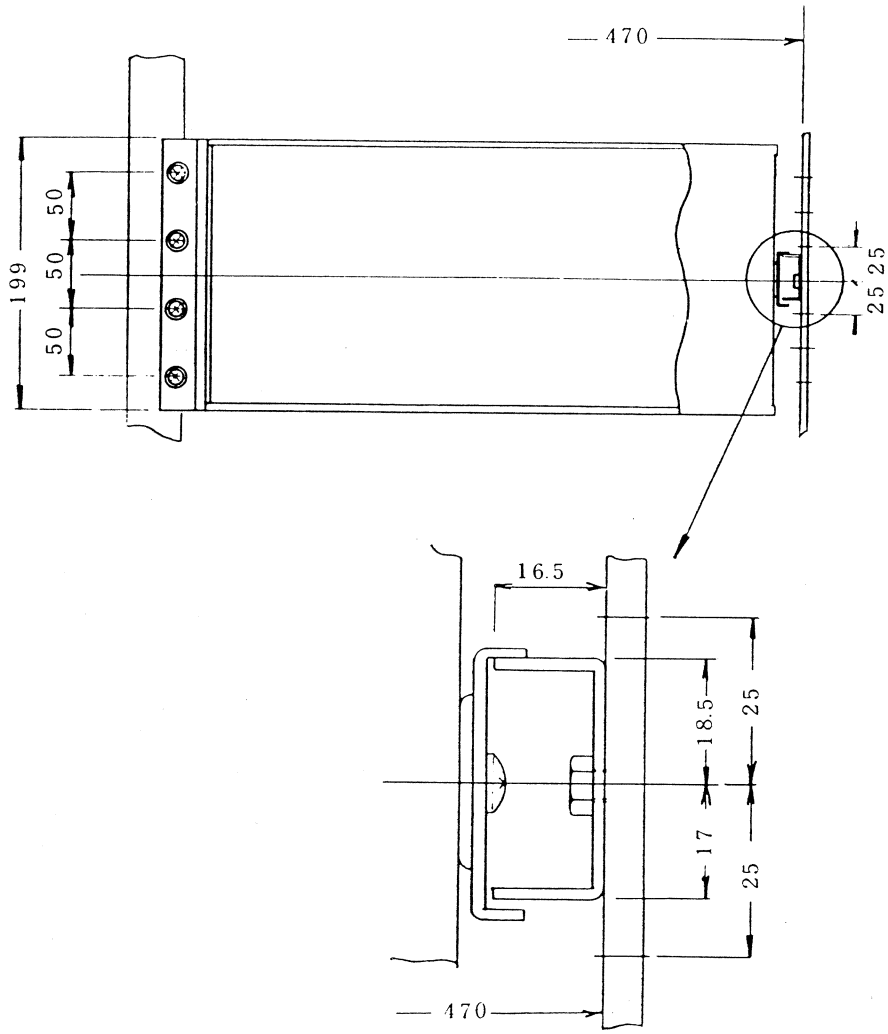

Fig. 2-9 Rack mounting (2)

3. OPERATION

3.1 Names and Operation of Mainframe Parts

This section will serve to describe the various front and rear panel switches and connectors of the MS-523/525 mainframe. Refer to Fig. 3-1 and 3-2.

1 Functional Plug-In Slots

These slots are used to house functional plug-in units such as filter units and differential amplifier units and any units other than control units. The MS-523 functional plug-in slots are numbered 0 thru 7 while those for the MS-525 are numbered 0 thru 15.

2 Control Slot

This control slot is used to house the P-41 Control Unit or the P-42 GP-IB Unit. In the MS-523 this is slot 8 and in the MS-525 this is slot 16.

3 Pilot Lamp

This pilot lamp lights whenever the mainframe has been powered on.

4 POWER PULL ON (Power Switch)

This is the mainframe power switch. When pulled, the power supply is turned on, whereupon the pilot lamp above the switch will light.

5 10A QUICK DC Fuse (MS-523)

This is the holder used for the fuse used for DC operation. A 10A fast-blow fuse is installed in this holder. A flat-blade screwdriver is used to remove the fuse for replacement.

6 DC Power Supply Input Terminal Board (MS-523)

This terminal board is used to apply DC power when the mainframe is powered from

a DC source. The "+" terminal is connected to +12V, while the "-" terminal is connected to 0V. For details, refer to section 2.6.1.

7 OUTPUT Centralized Output Connector

This connector provides a centralized access to the outputs of all functional plug-in units and the multiplexer. A 24-pin connector is used on the MS-523, and a 50-pin connector is used on the MS-525. For details, refer to section 3.2.

8  Ground Terminal

This is the cabinet ground terminal. It should always be connected to a ground.

9 AC/DC Switch (MS-523)

This switch is used to select 12VDC or 100VAC operation. Verify the proper setting of this switch before applying power.

10 AC Power Supply Input Connector

This connector is used to apply AC line power to the mainframe. For the MS-523, this source should be a 100VAC $\pm 10\%$ line source, and for the MS-525, depending upon the setting of the switch above this connector, the source may be 100, 120, 220, or 240VAC $\pm 10\%$.

A fuse holder is located below this connector and this fuse holder houses a spare fuse as well as the operating fuse.

For details, refer to section 2.6.

11 100V 220V +0V +20V Power Supply Switches (MS-525)

Combinations of these switches are used to select 100, 120, 220, or 240V line power voltage. The allowable voltage range is $\pm 10\%$ of the setting. For details, refer to section 2.6.2.

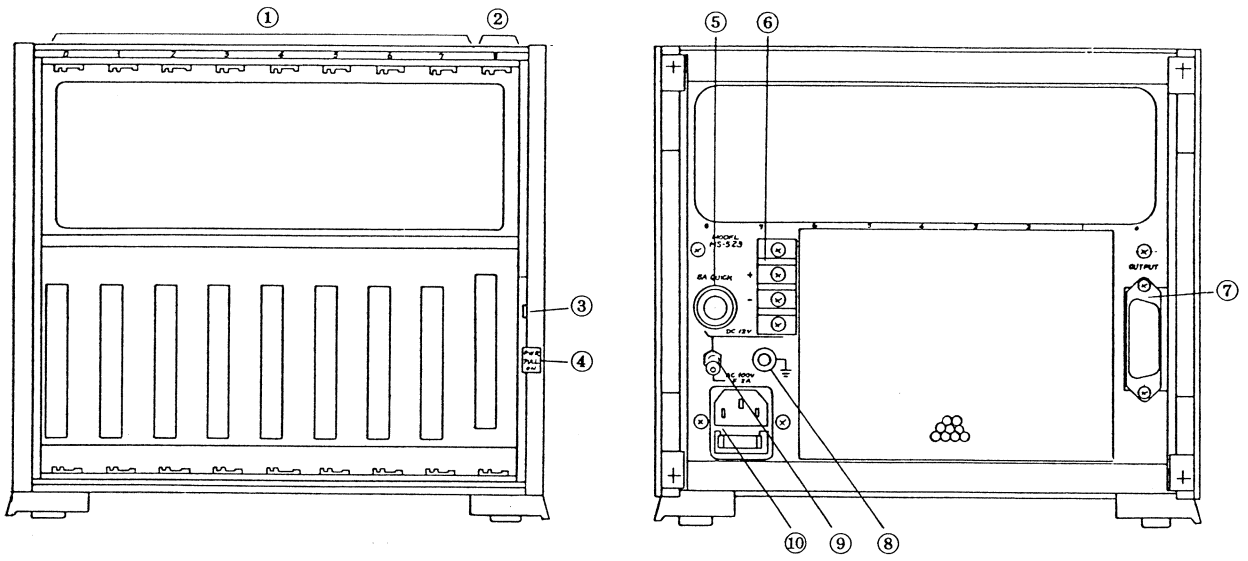

Fig. 3-1 MS-523 Front/rear panels

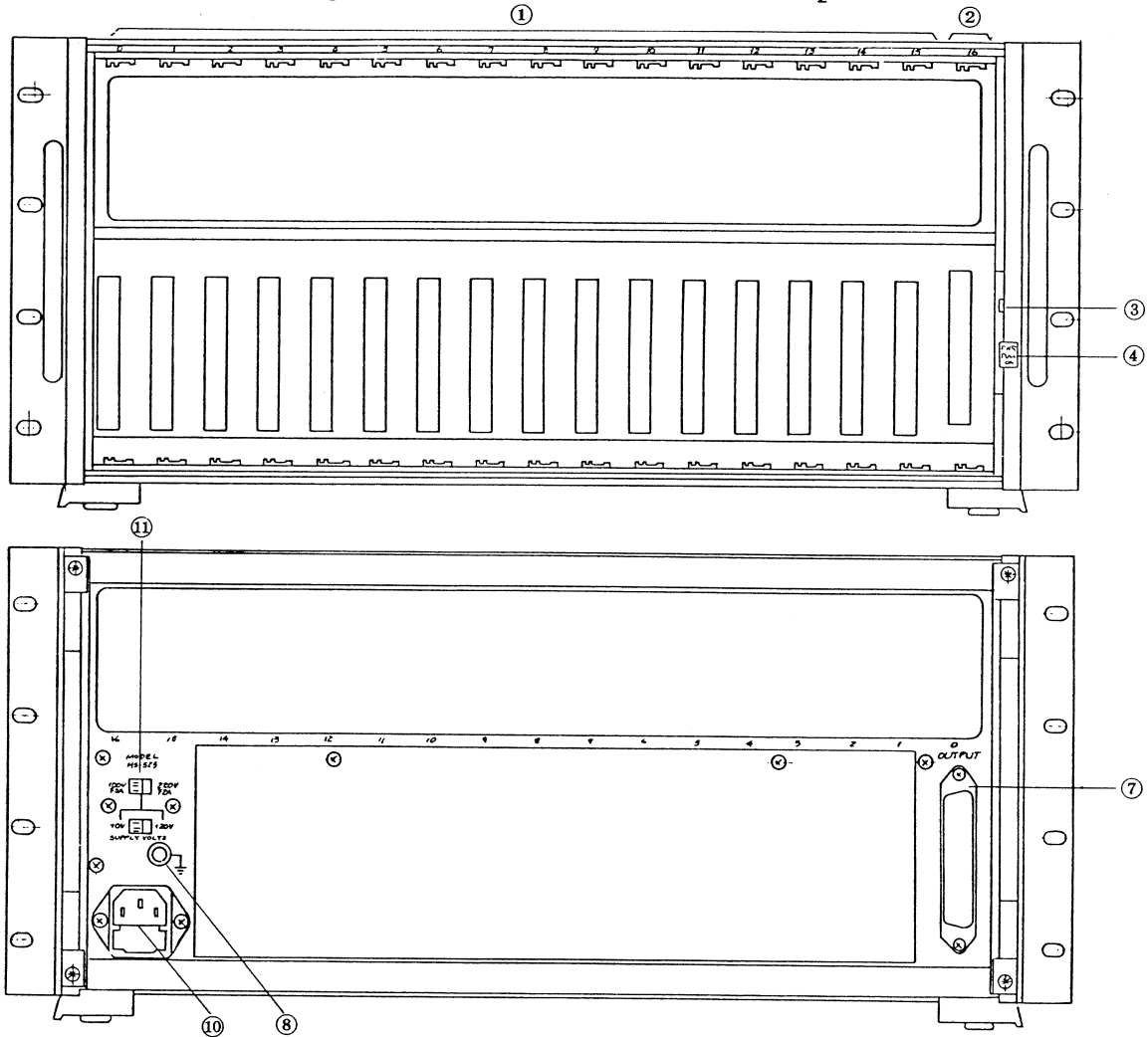

Fig. 3-2 MS-525 Front/rear panels

3.2 Initial Setup

Follow the procedure below for initial setup of the MS-523/525 mainframe.

- 3.2.1 Insert the plug-in units in accordance with sections 2.4 and 2.5.
- 3.2.2 Set the rear panel switch (ES) to the power supply voltage to be used, in accordance with section 2.6. For the MS-523, this will be 100VAC or 12VDC, and for the MS-525, this will be 100, 120, 220, or 240VAC.
- 3.2.3 Connect the power supply cable and pull the power supply switch. The unit will become operative. If the unit is to be repowered after turning the power off, wait several seconds before reapplying power.

CAUTION

- o Always remove the mainframe power before inserting or removing plug-in units.
- o Always remove the power supply before changing the power supply voltage setting.
- o Always wait several seconds before reapplying power to the mainframe.

3.3 Centralized Output Connector

This connector provides a centralized access to the outputs of all functional plug-in units and the multiplexer, and provides individual grounds for each of these lines. The multiplexer output is controlled from the control unit and this output is available only when the functional plug-in units have the multiplexer function.

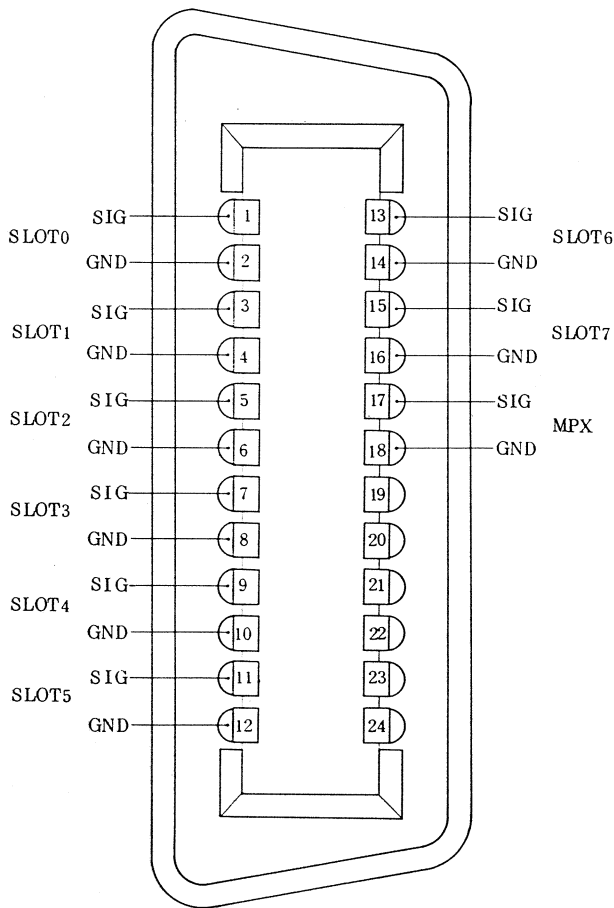

Fig. 3-3 MS-523 Centralized output connector

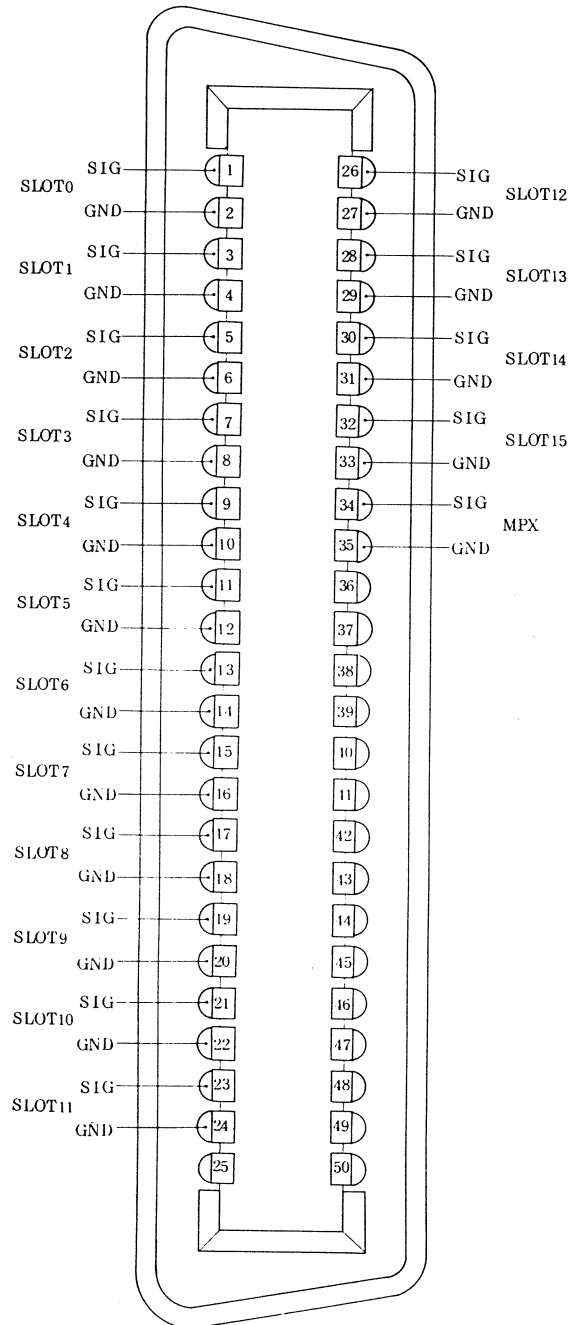

Fig. 3-4 MS-525 Centralized output connector

4. PRINCIPLE OF OPERATION

4.1 Outline

The MS-500 Series is a multi-channel measurement system consisting of a mainframe and plug-in units. This section will serve to describe the signal flow within the system, as well as the control system operation.

The plug-in units can be divided between functional plug-in units that are used to process (amplifier, filter, or otherwise modify) actual analog signals and the control units (GP-IB interface and simultaneous controller, etc.) used to control the units remotely.

Between each of the units, an analog bus line and digital bus lines are used as interconnections.

Analog signals consist of the inputs and outputs from each channel, the outputs being collected on a centralized connector.

The digital bus line consists of eight data lines, six address lines, and four control lines, for a total of 18 bits. This bus line connects each channel with the control unit.

The data lines are basically used to transmit setting conditions (cutoff frequencies, gains, etc.) to the various units. They are used not only when performing settings and verification settings, but also at other times such as for transmission of the model code.

The address lines are used to specify the slot number, and are used to specify the slot to which data is sent.

The control lines consist of the LOCAL REMOTE, INPUT/OUTPUT, LOCAL LOCK, and STROBE LINES, used in combinations depending upon the item to be controlled.

Using the P-42 Control Unit, the digitized conversion of the multiplexer output is available as a data output.

4.2 MS-523 Block Diagram

The MS-523 consists of a mainframe with eight functional plug-in slots and one control slot. It differs from the MS-525 in that it has only half (eight) of the functional plug-in slots and in that it may be operated from a battery or other DC power source. (Refer to Fig. 4-1.)

Slots 0 thru 7 are the functional plug-in slots, and slot 8 is used for the control unit.

Each slot is powered by +24V and +5V and the slots are connected by a logic control bus line and analog multiplexer bus line. A centralized output connector is provided on the rear panel to provide access to the various functional plug-in slot output lines and multiplexer lines, as well as the grounds associated with these lines.

A switch is used to select 100VAC power or 12VDC power, power regulation being provided by a DC/DC converter and partial series regulator.

4.3 MS-525 Block Diagram

The MS-525 consists of a mainframe with 16 functional plug-in slots and one control slot (refer to Fig. 4-2 for the MS-525 block diagram).

Slots 0 thru 15 are functional plug-in slots and slot 16 is used for the control unit.

Each slot is powered by +24V and +5V and the slots are connected by a logic control bus line and analog multiplexer bus line. A centralized output connector is provided on the rear panel to provide access to the various functional plug-in slot output lines and multiplexer lines, as well as the grounds associated with these lines.

Two slide switches marked 0V/+20V and 100V/220V are used to select any of four line power voltages. This power supply includes also series regulators which provide +24V and +5V outputs for the individual slots.

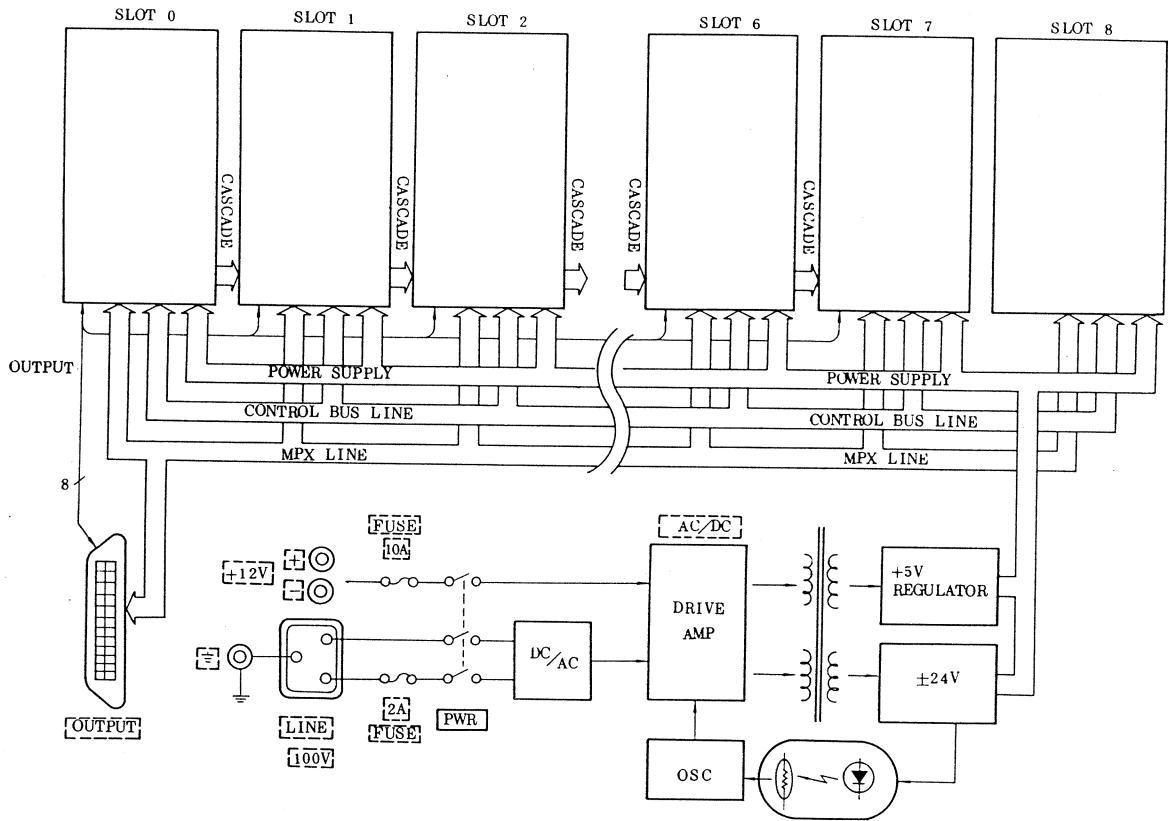

Fig. 4-1 MS-523 Block diagram

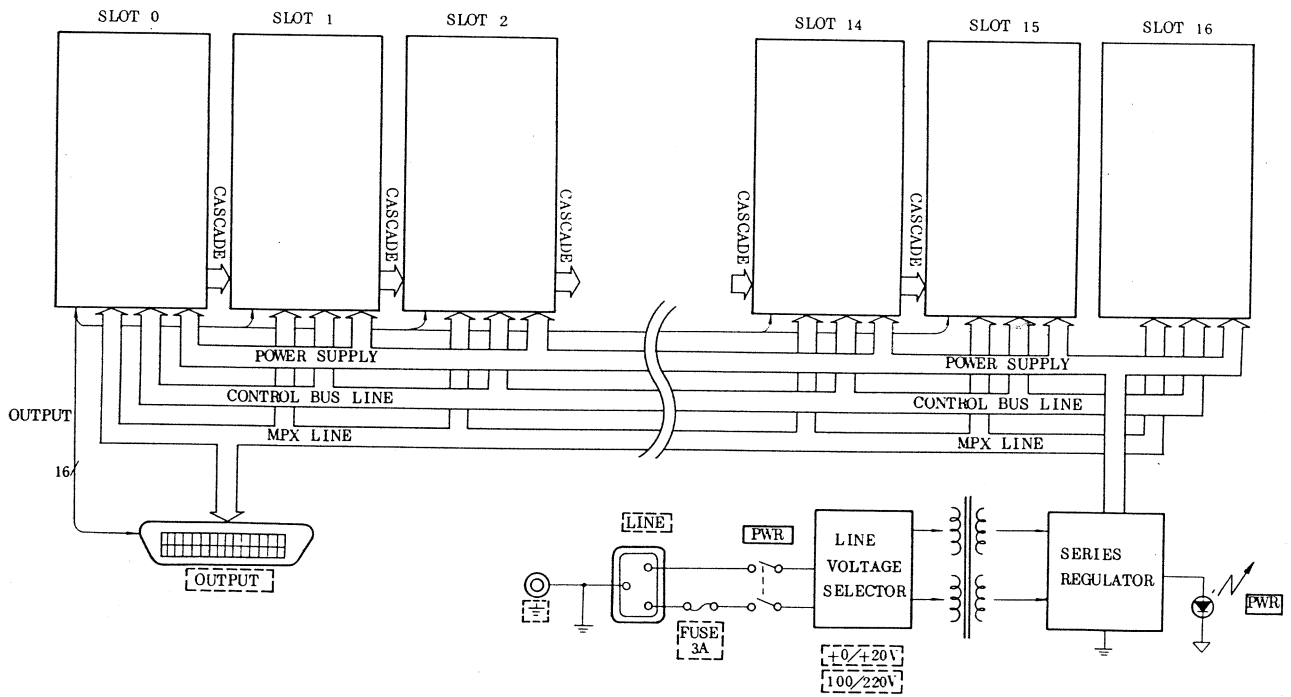

Fig. 4-2 MS-525 Block diagram

4.4 Connections to the Individual Plug-In Units

Connections between the MS-523/525 mainframe and individual plug-in units are made by means of 50-pin card edge connectors at the rear of each slot. The pin arrangement is shown in Fig. 4-3.

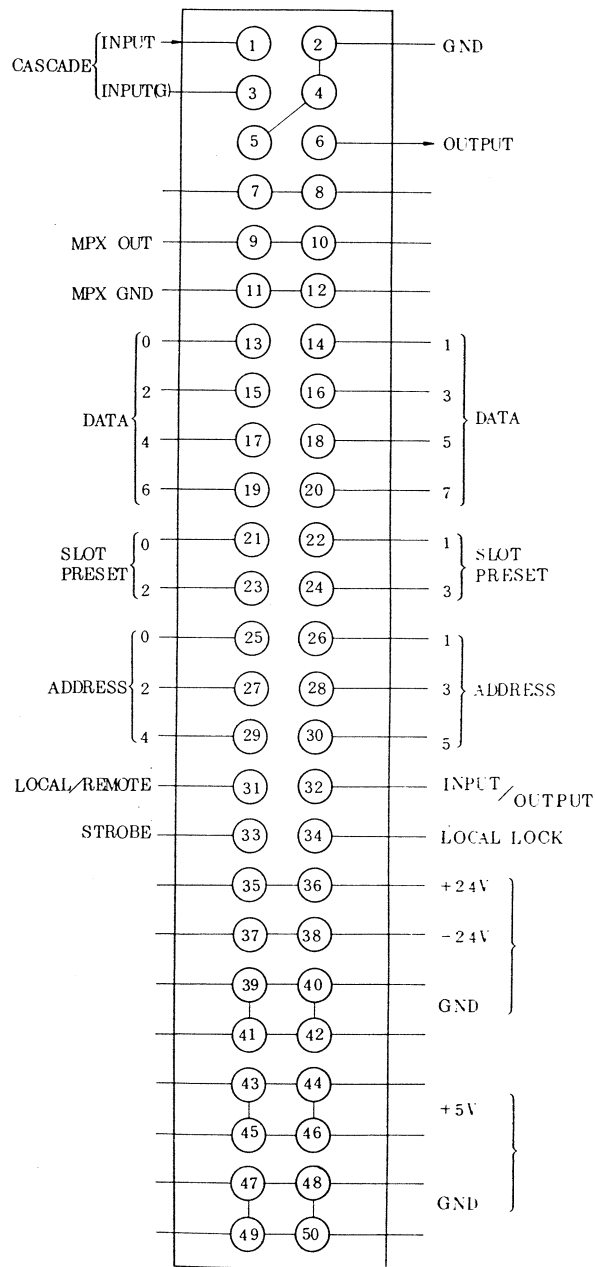

Fig. 4-3 Plug-in unit to mainframe interconnections

5. MAINTENANCE

5.1 Outline

Some maintenance is required to ensure that the MS-523/525 operates properly.

5.1.1 Operational Checks

This type of check is performed to verify that the mainframe is operating properly and satisfying specifications.

5.1.2 Adjustment and Calibration

If the unit is not operating properly, adjustment and calibration at specified points is necessary.

5.1.3 Failure Diagnosis

If adjustment and/or calibration fails to correct the condition, failure diagnosis is performed to discover the cause and location of the failure.

5.1.4 Repair

This document describes operational checks and adjustment procedures for the mainframe with all plug-in units removed. It provides only incidental information on operational checks with the units installed in the mainframe.

CAUTION

- o For operational checks on individual units, refer to the instruction manuals for the particular units.

5.2 Operational Checks

The MS-523/525 mainframe has the following three major functions.

1. Housing and provision of power supplies for the plug-in units.
2. Interconnection with the various units using the bus line, and receiving and sending of the control signals.
3. Feeding of the outputs of the various slots to a centralized output connector and to a slot connector at the right side of the unit used for cascade connections.

In addition to checking the above three basic functions, it is necessary to check the MS-525 line voltage switch setting (100/120/220/420VAC), and the MS-523 100VAC/12VDC input power selection setting.

5.2.1 Installation of Plug-In Units

Install the units in the mainframe. This should be done without forcing units into the slots and should be done as to ensure a reliable mating into the slot and locking using the locking screw at the bottom of each unit.

It is not possible to install functional plug-in units into the control slots, nor is it possible to install a control unit into a functional plug-in slot. If this is attempted, there is a danger of damaging the slot connector as well as the unit interconnection section. Extreme care should be taken in this respect.

5.2.2 Output Voltage Checks

Before checking the voltages, verify that the forced air cooling fan at the rear of the mainframe is rotating. Next, verify the DC voltages being supplied to each unit. The DC voltages at the pins indicated in Fig. 5-1 should be checked using a digital voltmeter, to verify that they fall within the limits shown in Table 5-1.

+24V	Between (35) and (39) (40) (36) (41) (42)	+26V ~ +23V
-24V	Between (37) and (39) (40) (39) (41) (42)	-26V ~ -23V
+5V	Between (43) (44) and (47) (48) (45) (46) (49) (50)	+4.8V ~ +5.2V

Table 5-1 Output Voltages

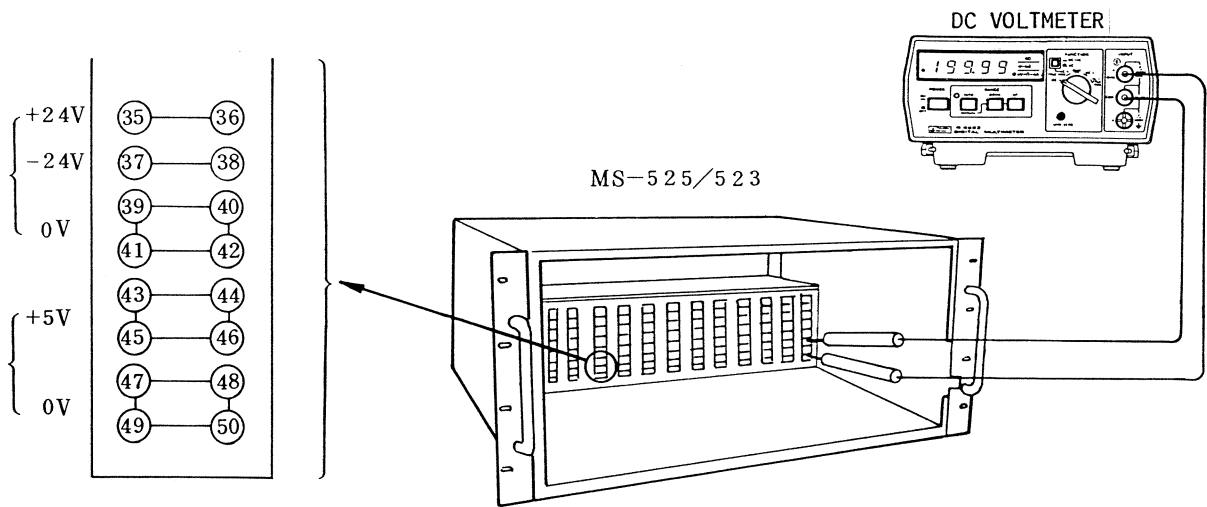

Fig. 5-1 Output voltage check pin positions

While a single power bus exists in the MS-523, the MS-525, as shown in Fig. 5-2, has three separate +5V power busses and two separate +24V power busses.

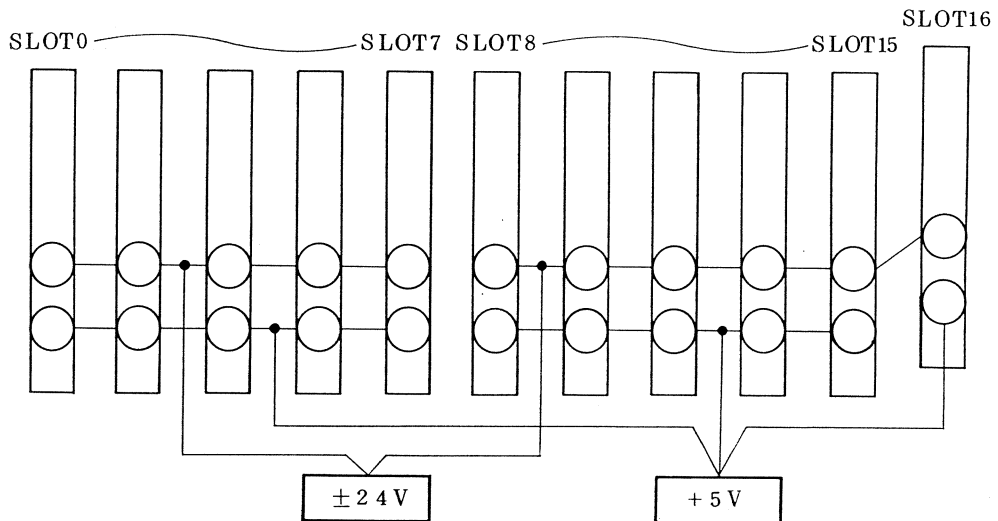

Fig. 5-2 MS-525 Power supply bus configuration

While it is probably sufficient to check the single power feed connector on the MS-523 or the three power feed connectors (slots 0, 8, and 16) on the MS-525, since a connector failure might be the cause of trouble also, voltage should be checked at all connectors.

When making connector checks, avoid inserting test leads into the connector from the unit side. This check, instead, should be made from the inside of the unit, contacting the pins lightly. This is to avoid failures caused by deformation of the contact pins or damage to the gold plated surfaces thereof.

CAUTION

Do not insert test leads into the connectors.

5.2.3 Bus Line Checks

(a) Control Bus Lines

Control signals are sent and received when a control unit has been installed in the control slot and master/slave control or GP-IB control is used to remotely control the functional plug-in control units in the external control mode.

Install a functional plug-in unit and a control unit into the mainframe and set the functional plug-in unit into the remote mode, verifying that the unit operates normally. This verifies that the control bus line is operating properly. (Refer to the individual instruction manuals for each unit with regard to operational checks.)

Should operational problems be detected, it is necessary to determine whether the problems exist with the unit itself or with the mainframe. Operate the functional plug-in unit in the local mode (selected from the front panel). If it does not operate properly, the cause of the trouble is with the unit itself. If it operates properly, the cause may be in the mainframe.

Perform a check of the control bus lines according to Fig. 5-3.

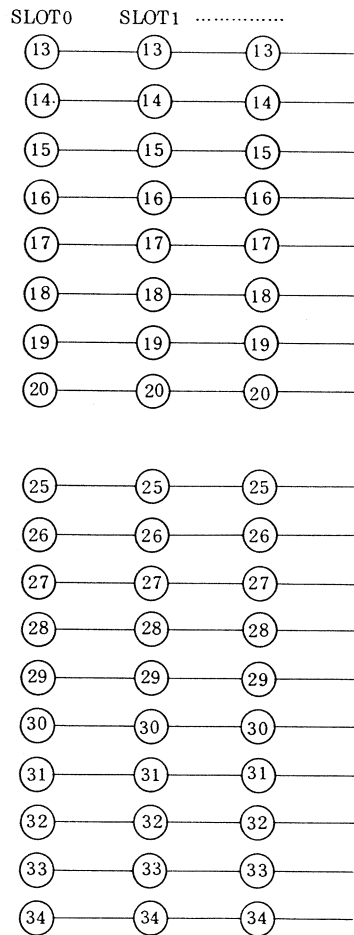

Fig. 5-3 Control bus lines

When checking continuity, always switch the power switch off first. Note that with the power switch on, a voltage of approximately +3V will be present on the control bus lines.

(b) Slot Number Presetting

This 4-bit code is a slot number that indicates to the unit which slot in which it is installed. If this slot number is not set correctly, incorrect slots will be addressed

in the GP-IB control mode and for master/slave control, receiving and sending of control signals between the master and slave will not be performed properly.

	SLOT 0	SLOT 1	SLOT 2	SLOT 3	SLOT 4	SLOT 5...
②1	0	1	0	1	0	1
②2	0	0	1	1	0	0
②3	0	0	0	0	1	1
②4	0	0	0	0	0	0

0: 0V
1: 5V

Table 5-2 Slot Number Presetting Codes

(c) Multiplexer Bus Line

This analog bus is used to transmit the multiplexer outputs from each functional plug-in unit. Each pair of lines consists of a signal line and a ground line.

Check them according to Fig. 5-4.

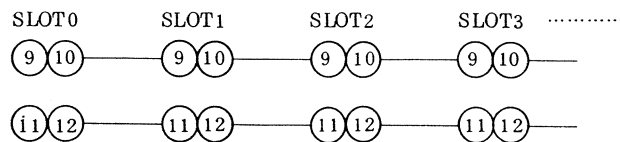

Fig. 5-4 Multiplexer bus line

(d) CASCADE Line

For general-purpose units which feature a CASCADE mode, this line is used to feed the output from the slot at the left side. Install a unit having this CASCADE mode into the mainframe and verify that proper cascading is possible. If it is, these lines are operating normally. (Refer to the individual instruction manuals for each unit with regard to operational checks.)

Should operational problems be detected, it is necessary to determine whether the problems exists with the unit itself or with the mainframe. Set the unit operational mode to some mode other than CASCADE and apply an input signal, verifying operation.

If proper functioning is not observed, the trouble is in the unit itself. If functioning is proper, the trouble may be in the mainframe.

The cascade line connections are shown in Fig. 5-5 and should be checked accordingly.

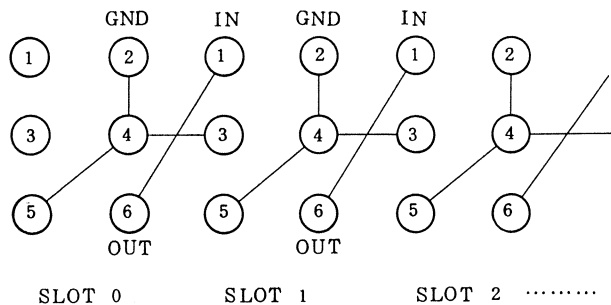

Fig. 5-5 Cascade line connections

5.2.4 Centralized Output Check

As shown in Fig. 5-6 and 5-7, the rear panel centralized output connector provides ground lines for each individual slot output, as well as two lines for the multiplexer output and its ground.

Insert all the units you have into the mainframe and apply input signals to each unit to obtain a suitable output signal at the monitor BNC output connector at the bottom of each of the unit front panels. Check that the proper outputs at these BNC connectors are observed at the corresponding rear panel centralized output connector pins.

Should some abnormality be discovered, it is possible that a connection or connections to the mainframe rear panel centralized connector has opened.

Verify that the connections shown in Fig. 5-8 and 5-9 are normal.

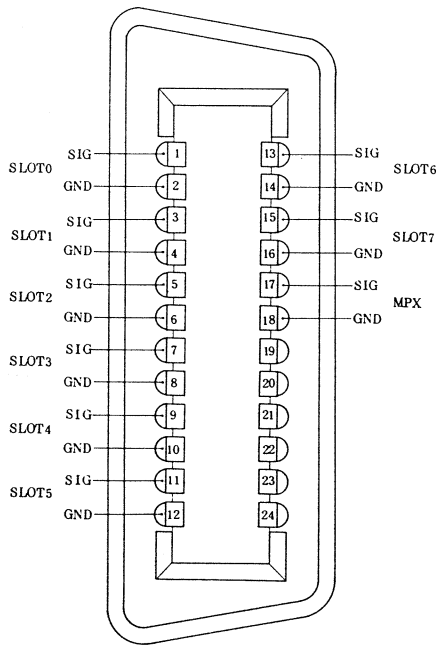

Fig. 5-6 MS-523 Centralized output connector

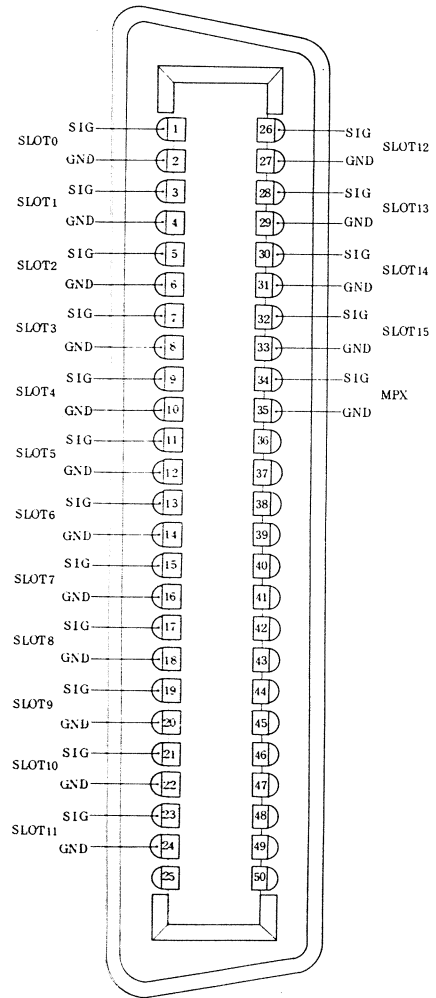

Fig. 5-7 MS-525 Centralized output connector

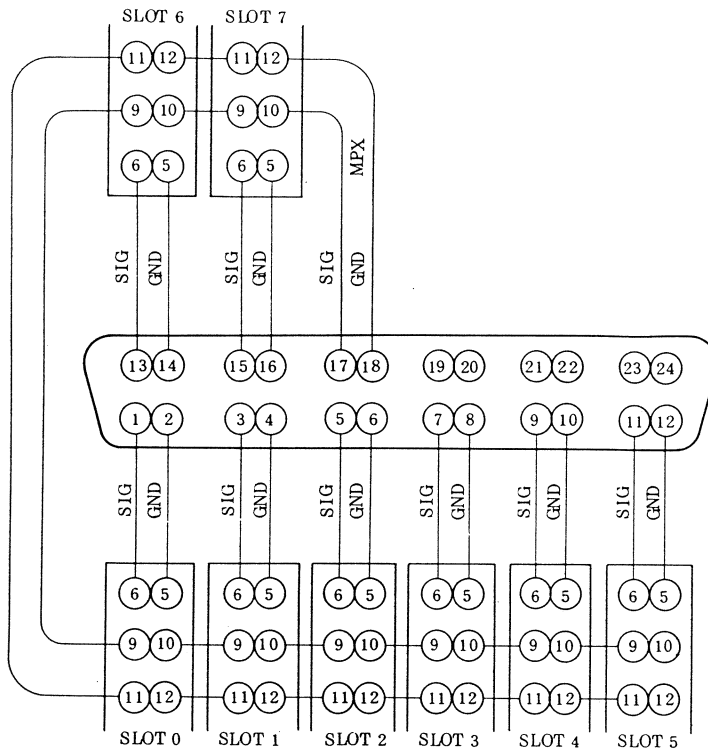

Fig. 5-8 Centralized output connector wiring (MS-523)

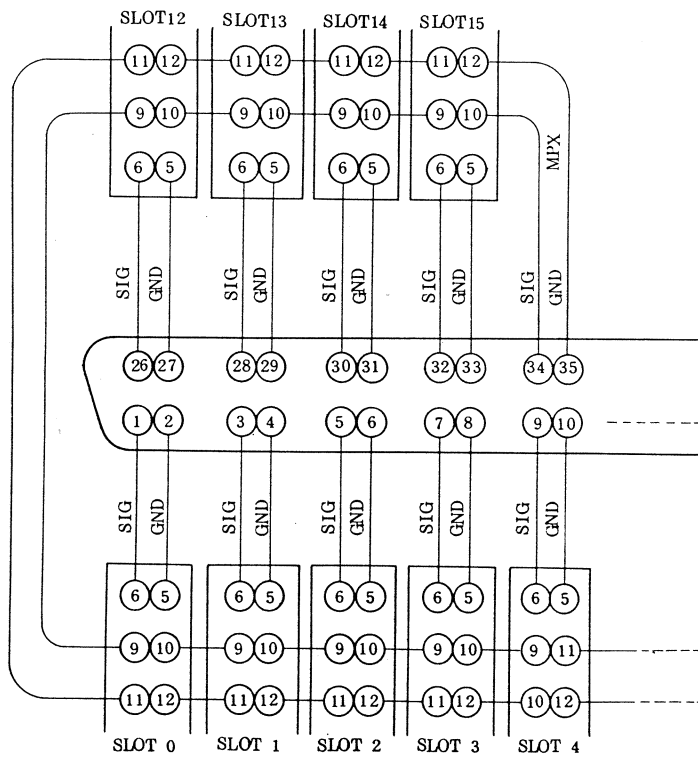

Fig. 5-9 Centralized output connector wiring (MS-525)

5.3 Calibration of Plug-In Unit Power Supplies

The following describes the procedure for using trimmers to adjust the value of voltages fed to the plug-in units, should this voltage value be outside the specified limits.

5.3.1 MS-525 Voltage Calibration

For the MS-525, it is possible to adjust the +5V output. Refer to Fig. 5-10, removing the two screws and the rear cover.

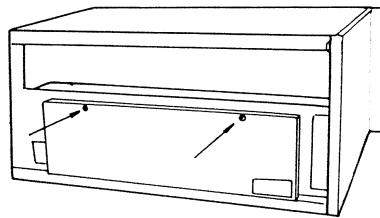

Fig. 5-10 Rear cover removal (MS-525)

Adjust trimmer RV101 on the regulator board so that the voltage between pins (43, 44, 45 and 46) and (47, 48, 49 and 50) is +5V. These pins are on the rear board connector.

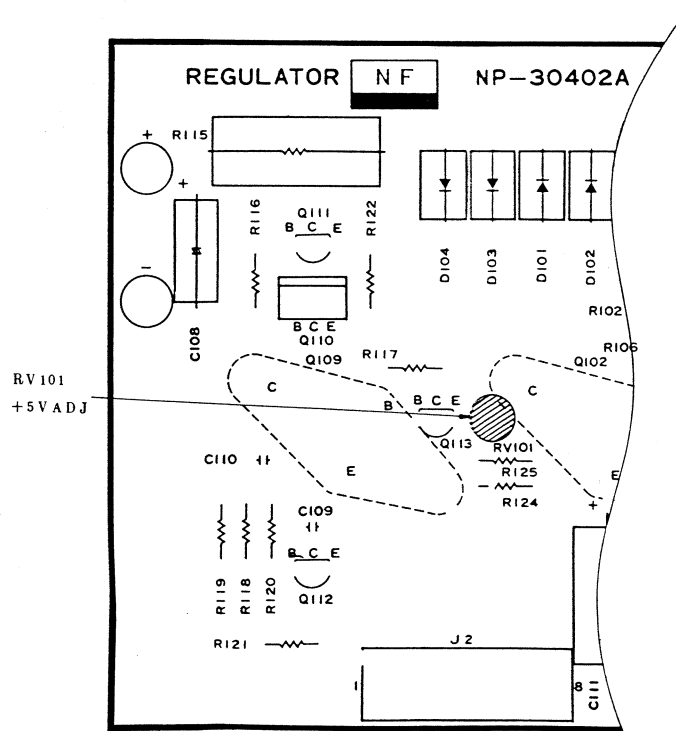

Fig. 5-11 +5V Output adjustment (MS-525)

5.3.2 MS-523 Voltage Calibration

For the MS-523, the +24V and +5V outputs may be adjusted. Refer to Fig. 5-12, removing the four rear guard screws and removing the side plates towards the rear.

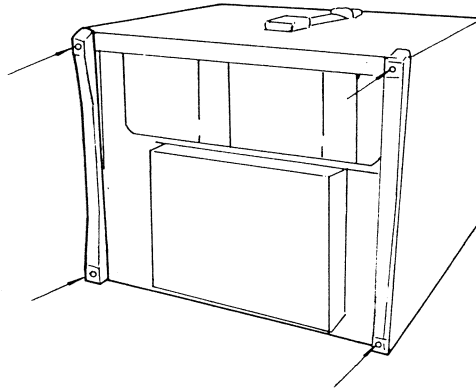

Fig. 5-12 Side plate removal (MS-523)

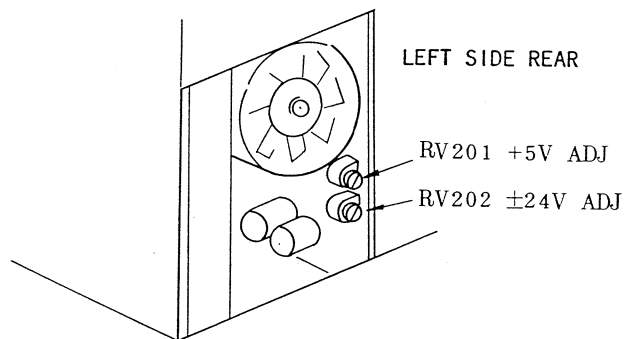

Fig. 5-13 ±24V and +5V Adjustment (MS-523)

Trimmer RV201 Adjustment: Adjust so that the voltage between pins (43, 44, 45 and 46) and (47, 48, 49 and 50) is +5V.

Trimmer RV202 Adjustment: Adjust so that the voltage between pins (35 and 36) and (39, 40, 41 and 42) is +24V.

WARRANTY

NF CIRCUIT DESIGN BLOCK CO., LTD. certifies that this instrument was thoroughly tested and inspected and found to meet its published specifications when it was shipped from the factory.

All **NF** products are warranted against defects in materials and workmanship. Obligations under this warranty are limited to replacing, or repairing of any instrument returned to our factory for that purpose within one year of delivery to the original purchaser. No other warranty is expressed or implied. **NF** does not assume liability for installation or for incidental or consequential damages.

NF CIRCUIT DESIGN BLOCK CO., LTD.

6-3-20 Tsunashima Higashi, Kohoku-ku, Yokohama-shi,

223 JAPAN

Phone (045) 542-0411

