



MULTIFUNCTION FILTER

3611

OPERATION MANUAL

3611
Multifunction Filter
Operation Manual

Foreword

Thank you very much for procuring the 3611 Multifunction Filter. At the outset, please take a few minutes to read the Safety Precautions indicated in this manual in order to use this equipment safely and correctly.

● Warning and Caution notices

The following Warning and Caution notices appear in this manual. These must be observed in order to protect both the user from physical harm and the equipment from damage.

WARNING

Risk of serious and possibly fatal physical injury from electric shock or other cause.

CAUTION

Risk of damage to the equipment.

● Manual composition

Section 1 Overview

Provides a general description of the equipment.

Section 2 Preparation

Required preparatory work before installing and operating the equipment. Be sure to read this section.

Section 3 Operations

Panel functions and operations are described. Read while operating the equipment.

Section 4 Maintenance

Inspection and performance tests are described.

Section 5 Typical data

Amplitude and phase response of the equipment are described.

Section 6 Specifications

Equipment specifications are described.

Safety Precautions

Observe the following warnings and cautions in order to use this equipment safely. No responsibility or warranty is assumed for damages arising from use in a manner contrary to these warnings and cautions.

● **Observe text instructions**

This manual has been compiled in order to enable safe operation and use of this equipment. Be sure to read this manual before using the equipment.

Items designated by Warning advise of serious physical hazards. Be sure to observe these carefully.

● **Be sure to connect ground**

Since the unit includes a built-in line filter, there is risk of shock if used without grounding.

Be sure to properly connect the ground. By connecting the 3 conductor power cable to a grounded 3-terminal wall socket, the equipment is automatically grounded.

● **Confirm power source voltage**

Before connecting this equipment, check that the proper voltage is being supplied to the power outlet.

Refer to the Grounding and Power Supply section of this manual.

● **Use only the properly rated fuse**

Improperly rated fuses present a fire hazard and other risks. Refer to the Grounding and Power Supply section of this manual and confirm the fuse rating.

Be sure to disconnect the equipment from the power source before replacing the fuse.

● **Smoke, odor, noise**

In event smoke, peculiar odor or noise is emitted, immediately disconnect the power source and avoid further operation. Contact service.

● **Flammable gas**

Do not use this equipment in the presence of flammable gas. There is danger of fire and explosion.

● **Do not remove covers**

This equipment contains dangerously high voltages. Do not remove external covers.

Refer all internal inspection and service to a qualified service technician who fully understands the hazards.

● **Do not modify**

Do not use parts other than specified by the manufacturer and by no means attempt to modify the equipment.

There is risk of personnel hazard and damage to the equipment. The manufacturer reserves the option of refusing service in such cases.

● Safety indications

Notices designated by WARNING and CAUTION are indicated in this manual and on the equipment. These are defined as follows.



Advises of possible hazard to the user, as well as the need to consult this manual when using an operation or function.



Appears in the text and on the product to advise risk of fatal or otherwise serious physical injury.

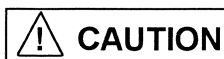

Appears in the text and on the product to advise risk of damage to the product.

Table of Contents

	page
Foreword	(1)
Safety Precautions	(2)
Table of contents	(5)
Section 1 Overview	1
Section 2 Preparation.....	3
2.1 Check before using	3
2.2 Grounding and power source.....	4
2.3 Installation.....	5
Section 3 Operations	7
3.1 Panel description	7
3.2 Operations	10
Section 4 Maintenance	13
4.1 Required equipment	13
4.2 Performance checks.....	13
4.3 Adjustment procedure.....	15
Section 5 Typical Data	17
Section 6 Specifications	21
6.1 Filter section	21
6.2 Input section	22
6.3 Output section	22
6.4 Amplifier section	23
6.5 General	23

Section 1 Overview

The MODEL 3611 "Multifunction Filter" is a single-channel multifunction active filter, which is used for signal analysis, rejection of unwanted components, separation of significant components, etc. in such fields as vibration analysis, acoustics, physics and medical science.

The MODEL 3611 can be set at any of 6 functions, LOW-PASS FILTER (maximally flat or phase linear), HIGH-PASS FILTER, BAND-PASS FILTER, BAND-ELIMINATION FILTER, and THRU, by pushing buttons. The attenuation slope is 24 dB/OCT, and the BAND-PASS FILTER has 1/3 OCT bandwidths allowing simple frequency analysis to be made.

The cutoff or center frequency can be set between 0.1 Hz to 21.8 kHz by means of 2 decade dials and a 5 step multiplier.

In addition, the provision of gain and input-coupling switching permits the MODEL 3611 to be applied to still broader fields.

Features:

- Frequency setting by means of easy-to-read decade dials of excellent repeatability.
- Capable of being set at LOW-PASS (2 kinds), HIGH-PASS, BAND-PASS, or BAND-ELIMINATION function with one-touch.
- Capable of simple frequency analysis employing 1/3 OCT bandwidths.
- Ample output voltage and current: ± 10 V/no-load, ± 20 mA.
- Changeover of gain from 1 to 10 times and input coupling from DC to AC are provided.

Section 2 Preparation

2.1 Check before using

■ Safety check

Before using the 3611, refer to the **Safety Precautions** of this manual and confirm safety.

Also, before connecting the power, refer to **Section 2.2 Grounding and Power Source** and thoroughly check the safety.

■ Unpacking and repacking

First, inspect the equipment for possible damage in shipping.

Check for the presence of the following items.

Mainframe	1
Operation Manual	1
Supplied accessories	
Power cable (3-conductors, 2 meters)	1
Fuse (time lag, 0.2 A/250 V, 5.2 dia. x 20 mm	1

When repacking the equipment for transportation, use a packing carton having ample strength to protect the equipment and bear the weight of stacking.



WARNING

Do not remove covers.

This equipment contains dangerously high voltages. Do not remove external covers.

Refer all internal inspection and service to a qualified service technician who fully understands the hazards.

2.2 Grounding and power source

■ Grounding

WARNING

This equipment must be grounded in order to prevent electric shock accidents.

Confirm the protective ground terminal is connected to ground before connecting the equipment for measurements. The 3611 protective ground is connected to ground by the 3-prong power supply plug.

Use the supplied power supply cable to connect to a 3-terminal power outlet that has a protective ground contact.

■ Power source

CAUTION

Be sure to observe the following in order to prevent damage to the equipment.

Confirm the power source voltage is within the range specified for the 3611.

Check the power source voltage indication on the rear panel above the power source inlet. The 3611 operates from the following commercial power source.

Power supply voltage range : As indicated on rear panel

Power supply frequency range : 48 to 62 Hz

Power consumption : Max. 8 VA

Confirm the power switch is off before connecting the power cable.

■ Power supply fuse

WARNING

Use only a fuse with the specified rating.

There is risk of fire from an improperly rated fuse. Be sure to disconnect the power cable before replacing the fuse.

Fuse : time lag, 0.2 A/250 V, 5.2 dia. x 20 mm

2.3 Installation

■ Installation conditions

Observe the following ambient temperature and humidity ranges when installing and storing the equipment. Moisture condensation must also be absent.

Operating ambient: 0 °C to 40 °C, 10 %RH to 90 %RH (no condensation)

Storage ambient : -10 °C to 50 °C, 10 %RH to 80 %RH (no condensation)

Avoid installing the equipment in the following types of locations.

- In direct sunlight or near heat sources
- Where subjected to dust, salt or metallic dust
- Corrosive gas, steam or oily smoke
- Flammable gas or vapors
- Strong vibration
- Strong magnetic or electromagnetic fields
- Near pulse type noise sources

■ Panel and case cleaning

Use a soft cloth to wipe dust from the panel and case. If soiling is severe, moisten the cloth slightly with a neutral detergent.

Do not use sprays, petroleum distillates or commercial cleaning cloths, which can deform or peel the finish.

Section 3 Operations

3.1 Panel description

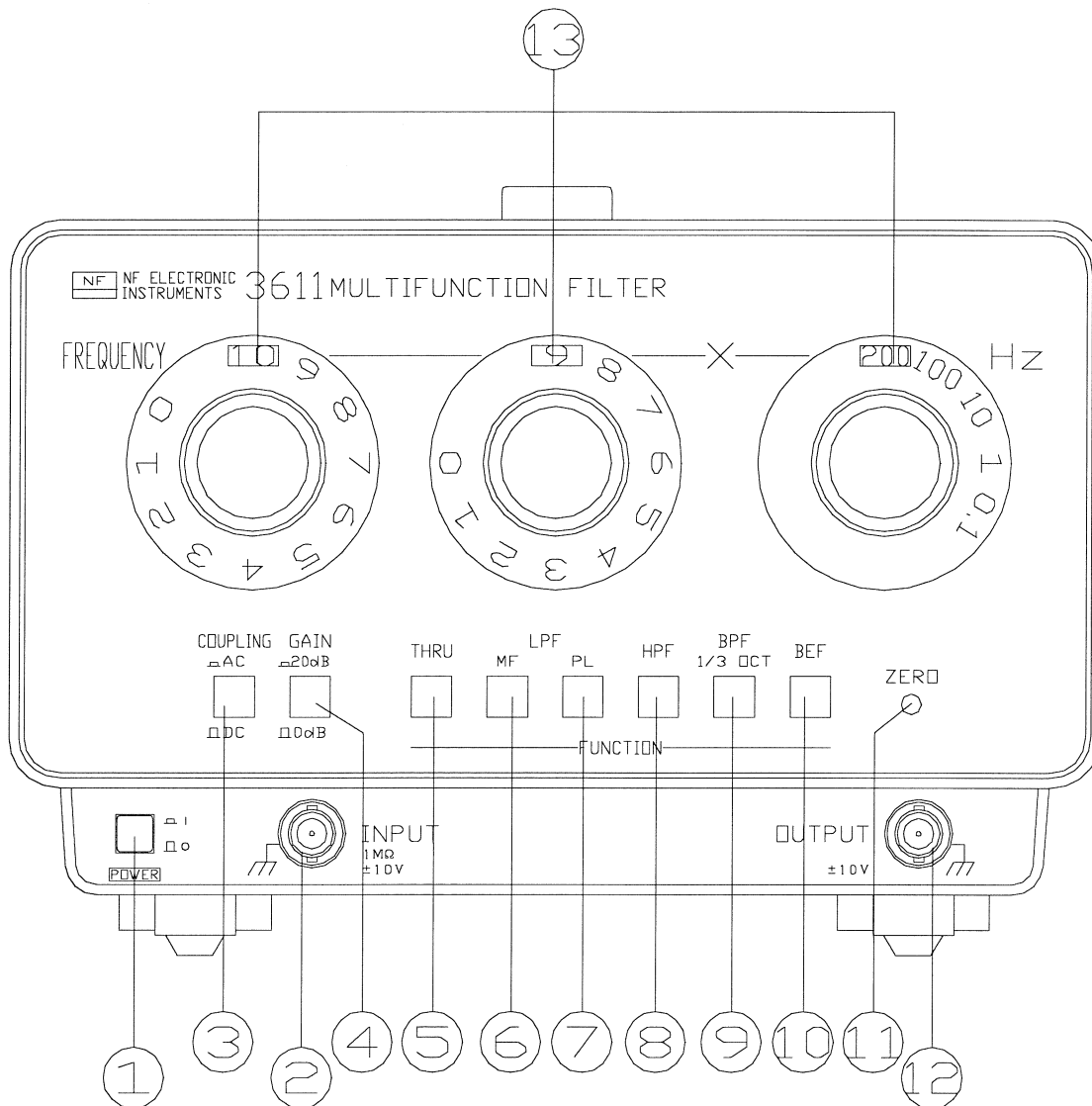

Fig. 3.1 Front Panel View

- | | |
|--------------|--|
| ① “POWER” | The power switch.
When pushed, lamp ⑬ will light. |
| ② “INPUT” | The connector for signal input.
The outside of the BNC connector is connected to the chassis. |
| ③ “COUPLING” | The switch for changing the input coupling. AC coupling is obtained when depressed. |
| ④ “GAIN” | The switch for changing the gain between input and output to either 0 dB or 20 dB (10 times). 20 dB gain is obtained when depressed. |
| ⑤ “THRU” | This switch, when depressed, will give an output unaffected by filter action. |
| ⑥ “LPF MF” | This switch, when depressed, will give the characteristics of a MAXIMALLY FLAT LOW-PASS FILTER. |

- ⑦ “LPF PL” This switch, when depressed, will give the characteristics of a PHASE LINEAR LOW-PASS FILTER.
- ⑧ “HPF” This switch, when depressed, will give the characteristics of a HIGH-PASS FILTER.
- ⑨ “BPF” This switch, when depressed, will give the characteristics of a BAND-PASS FILTER.
- ⑩ “BEF” This switch, when depressed, will give the characteristics of a BAND-ELIMINATION FILTER.
- ⑪ “ZERO” The potentiometer for adjusting the output offset voltage to zero.
- ⑫ “OUTPUT” The output terminals.
The outside of the BNC connector is connected to the chassis.

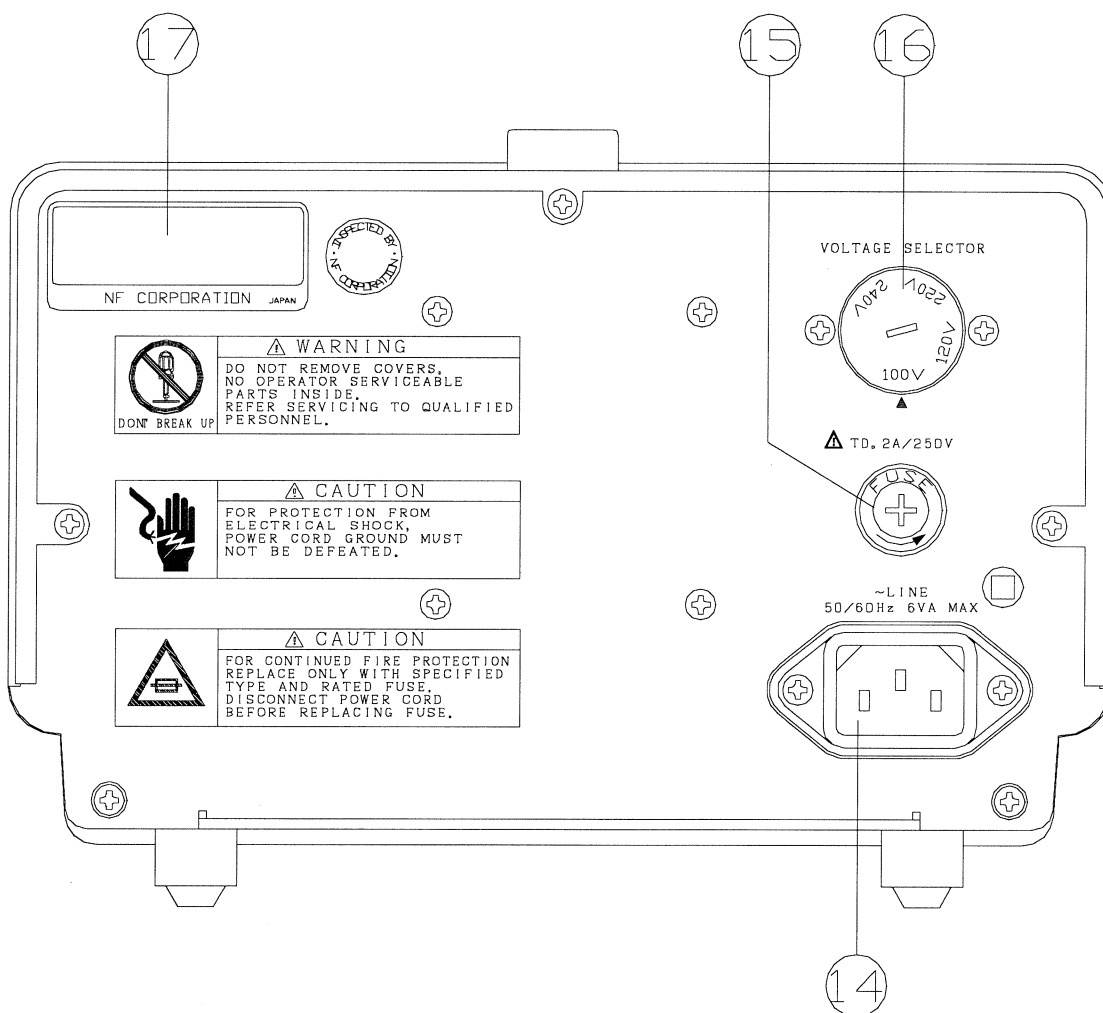

Fig. 3.2 Rear Panel View

- ⑬ “FREQUENCY” Dials for setting the cutoff or center frequency.
- ⑭ “~LINE” AC inlet connector
The accessory power cable is plugged into this connector.
- ⑮ _____ FUSE
Use 0.2 A time lag fuse.

 **WARNING**

Do not use a fuse other than specified.

- ⑯ “VOLTAGE SELECTOR” This switch for changing power supply voltage.
Unless otherwise specified, the MODEL 3611 is shipped from the factory with the supply voltage set to the voltage available in the customer’s country. Always check the supply voltage setting before first using the MODEL 3611. Before changing the supply voltage setting, always disconnect the power cable.
- ⑰ _____ The name plate
The name plate bearing the serial number of the instrument.

3.2 Operations

A. Turn On Procedure.

Plug the power cable into a receptacle of a power line of the specified voltage and frequency.

When switch ① POWER is pressed, the dial back-light lamp ⑬ will light, indicating that the 3611 is in an operating state.

B. Input Coupling & Gain Setting

First, apply an input signal with function switch ⑤ THRU depressed. Then, if the output is ± 1 V or less, when monitored with an oscilloscope or similar instrument, the output will not saturate when switch ④ GAIN is changed to 20 dB. If it is desired to reject DC or components below 1.6 Hz, depress switch ③ COUPLING to obtain AC coupling.

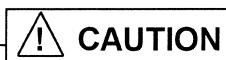

Before employing any of the filter functions, ascertain with the THRU function that the output does not saturate.

C. Function Setting

A function of the desired characteristic should be selected from among the LOW-PASS (maximally flat or phase linear), HIGH-PASS, BAND-PASS, or BAND-ELIMINATION functions.

The maximally flat (MF) function places importance on the amplitude response, and is designed so that the passband is of maximum flatness. In this function, phase lag is not proportional to frequency. In other words, since delay time is not uniform, phase distortion will occur. In the case of input signals such as square waves which have a fast rise time, waveform distortion like overshooting will appear.

The phase linear (PL) function places importance on the phase response, and is designed so that phase lag and frequency have maximum proportionality over the passband. Since delay time is uniform over the passband, little phase distortion is created.

For input signals having fast rise time such as square waves, waveform distortion like overshooting will be considerably reduced.

When waveform characteristic has to be considered, the phase linear (PL) function displays particular efficacy.

But, since its amplitude response drops near the cutoff frequency, when amplitude response also has to be considered the setting of the cutoff frequency should be selected carefully.

D. Setting of cutoff and center frequencies

In the case of LOW-PASS or HIGH-PASS filters, the cutoff frequency is set at a frequency situated between the desired and unwanted components of the signal.

In the case of BAND-PASS or BAND-ELIMINATION filters, the center frequency is set at desired frequency.

Frequency setting is accomplished with 2 decade dials and a multiplier, as follows:

For 0.5 Hz the setting is: $\underline{0} \ \underline{5} \times \underline{0.1}$

For 25 Hz the setting is: $\underline{2} \ \underline{5} \times \underline{1}$

For 720 Hz the setting is: $\underline{7} \ \underline{2} \times \underline{10}$

For 9.8 kHz the setting is: $\underline{9} \ \underline{8} \times \underline{100}$

For 15 kHz the setting is: $\underline{7} \ \underline{5} \times \underline{200}$

The dial settings for performing simple frequency analysis in 1/3 OCT steps are as follows:

1.0 1.3 1.6 2.0 2.5 3.2 4.0 5.0 6.3 8.0 10.0

Section 4 Maintenance

This section describes easy maintenance, and adjustment methods.

4.1 Required equipment

Oscillator	Frequency range:	10 Hz to 1 MHz
	Output voltage:	1 V or more
	Distortion factor:	0.01 % or less
Oscilloscope	Bandwidth:	DC to 10 MHz
	Sensitivity:	5 mV/DIV
Frequency Counter	Bandwidth:	0.1 Hz to 100 kHz
	Accuracy:	10^{-5}
Distortion Meter	Frequency range:	10 Hz to 100 kHz
	Range:	0.1 % full scale
AC Voltmeter	Bandwidth:	10 Hz to 1 MHz
(with dB scale)	Sensitivity:	1 mV to 100 V
Silicon Diodes	High-speed small signal type	
Fixed Resistor	3 k Ω , 0.25 W	

4.2 Performance checks

The following checks can be performed.

A. Accuracy of cutoff frequencies

The MODEL 3611 will become an oscillator, when connected as shown in Fig. 4.1. Therefore, the cutoff frequencies can be checked by simply connecting a frequency counter to the output connector, as follows.

- Connect the equipment as shown in Fig. 4.1.
- Set the relevant switches to "BPF", "GAIN 20 dB", and "COUPLING DC".
- Check whether the frequency counter reading is within ± 3 % of the cutoff frequency setting.

However, at cutoff frequencies above 5 kHz, due to phase rotation of the output amplifier, measurement error will become large. Therefore, the 3611 is operating normally if the frequency counter reading is within +2 % to -4 % for a cutoff frequency setting of 10 kHz, and within +1 % to -5 % for a frequency setting of 20 kHz.

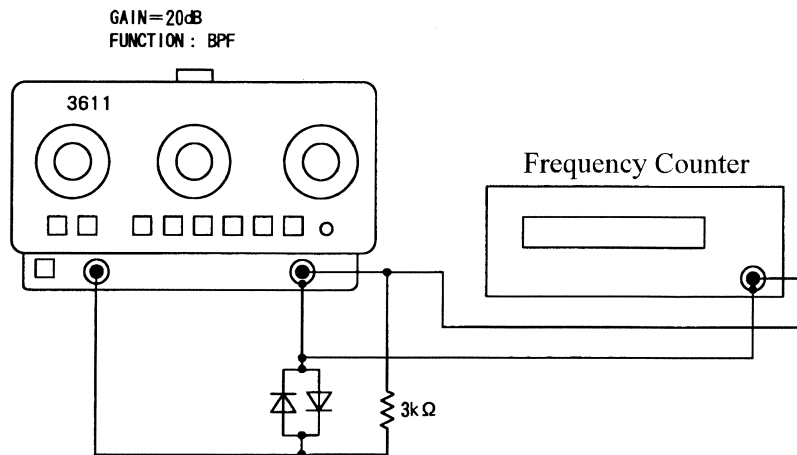

Fig. 4.1 Accuracy Check of Cutoff Frequencies

d) When the 3 kΩ fixed resistor in Fig. 4.1 is employed, a waveform approximating a sine wave will be obtained from the output connector.

B. LPF and HPF Attenuation Slope

a) Connect the oscillator output to the 3611 input, and the 3611 output to the AC voltmeter input. Set the oscillator frequency accurately with reference to the frequency counter.

b) Set up the 3611 as follows:

“FREQUENCY” 10 0 × 10 (1 kHz)

“GAIN” 0 dB

“COUPLING” DC

“FUNCTION” LPF-MF

c) Set the output of the oscillator to 100 Hz and adjust the level to 0dB of the 1V range of the AC voltmeter.

d) Change the frequency of the oscillator, so that the AC voltmeter shows -3 dB.

e) Double exactly the oscillator frequency of the -3 dB point above (should be approximately 2 kHz), and ascertain that the reading of the AC voltmeter at the doubled frequency is -24 ± 2 dB (typ).

C. Checking of Passband Gain

a) Measuring system connection and the 3611 setting are the same as B. a), b).

b) Set the oscillator output to 100 Hz, 0.5 V, and ascertain that the AC voltmeter reads $0.5 \text{ V} \pm 5 \%$.

c) Set the “GAIN” of the 3611 to “20 dB”, and ascertain that the AC voltmeter reads $5 \text{ V} \pm 5 \%$.

d) Set the “FUNCTION” of the 3611 to “BPF” and the oscillator frequency to 1 kHz.

Ascertain that the AC voltmeter reading is $5 \text{ V} \pm 15 \%$.

D. Checking of THRU frequency response

a) Connect the equipment as shown in Fig. 4.2 and set up the 3611 as follows.

“FREQUENCY” THRU

“COUPLING” DC

“GAIN” 0 dB

b) Set the oscillator frequency to 1 kHz and adjust the output level so that the AC voltmeter reads 0 dB.

- c) Ascertain that the AC voltmeter reading is within 0 to –3 dB when the oscillator frequency is set to 100 kHz.
- d) With AC coupling the frequency response will be approximately –2 dB at 2 Hz.

E. Checking of Distortion Factor

- a) Connect the oscillator output to the 3611 input, and the 3611 output to the distortion meter input.
- b) Set up the 3611 as follows:
 - “FREQUENCY” 10 0 × 1 (100 Hz)
 - “FUNCTION” HPF
 - “GAIN” 20 dB
- c) Set the oscillator frequency to 1 kHz, and the output level to 0.7 V.
- d) Ascertain that in this state the distortion factor is 0.05 % or less.

F. Checking of Offset Voltage

- a) Short the input of the 3611, and connect an oscilloscope or DC voltmeter to the output.
- b) Set up the 3611, in succession, to the following setting combinations.
 - “FREQUENCY” 10 0 × 1 (100 Hz)
 - “FUNCTION” All modes in succession
 - “GAIN” 0 and 20dB for each mode
 - “COUPLING” DC and AC for 0 and 20 dB gain
- c) Ascertain that the output offset voltage is less than ± 10 mV for all of the above settings.

4.3 Adjustment procedure

Adjustment of the Model 3611, other than adjustment of the offset voltage and that of the attenuation of BAND-ELIMINATION FILTER, cannot be simply performed.

A. Adjustment of Offset Voltage

Set up the 3611 as follows:

- Input terminals: Shorted
- “FREQUENCY” 10 0 × 10 (1 kHz)
- “FUNCTION” LPF-MF
- “GAIN” 0 dB
- “COUPLING” DC

Connect an oscilloscope or DC voltmeter to the output connector. Adjustment is made according to the following order, which must be strictly observed.

For R6, R11 and R19 refer to Fig. 4.4.

- a) Adjust “ZERO” on the 3611 front panel so that the output offset voltage is 0 V.
- b) Set “GAIN” to “20 dB”.
- c) Adjust R6 so that the output offset voltage is 0 V.

B. Adjustment of attenuation of BAND-ELIMINATION FILTER

- a) Connect the equipment as shown in Fig. 4.2.
- b) Set up the 3611 as follows:
 - “FREQUENCY” 10 0 × 10 (1 kHz)
 - “FUNCTION” BEF
 - “GAIN” 0 dB
- c) Set the oscillator output level to 20 Vp-p, and waveform to sine wave.
- d) Set the oscillator frequency to 1 kHz. Adjust the oscillator frequency slightly so that the frequency counter reading is 1 kHz ± 1 Hz.
- e) Adjust R11 so that the AC voltmeter shows minimum reading.
- f) Adjust R19 so that the AC voltmeter shows minimum reading.

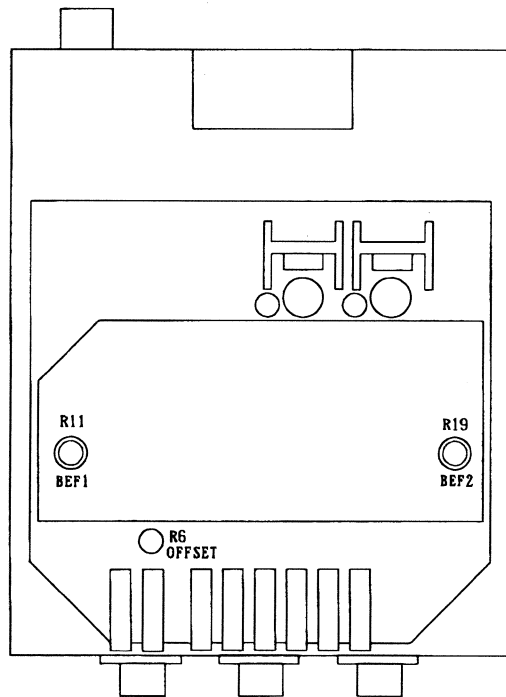

Fig. 4.2 Parts Location Diagram (top view)

Section 5 Typical Data

Typical data showing typical characteristics of the MODEL 3611 are appended to this manual.

NF CORPORATION exerts the utmost effort to minimize variations of characteristics between instruments of the same model. With this objective, the typical data is employed for Quality Control.

Since typical data are typical values based on the overall performance of many instruments, a particular instrument may not exactly conform to these values.

Nevertheless, all products are guaranteed to meet the published specifications, which are verified by strict final inspection prior to shipment from the factory.

LOW-PASS (MF: maximally flat & PL: phase linear) & HIGH-PASS FILTER

Amplitude Response:	Fig. 5.1
LOW-PASS & HIGH-PASS FILTER Phase Response:	Fig. 5.2
BAND-PASS FILTER Amplitude & Phase Response:	Fig. 5.3
BAND-ELIMINATION FILTER Amplitude Response:	Fig. 5.4
THRU Amplitude Response:	Fig. 5.5

Typical data, other than the above, are stated in next section "Specifications".

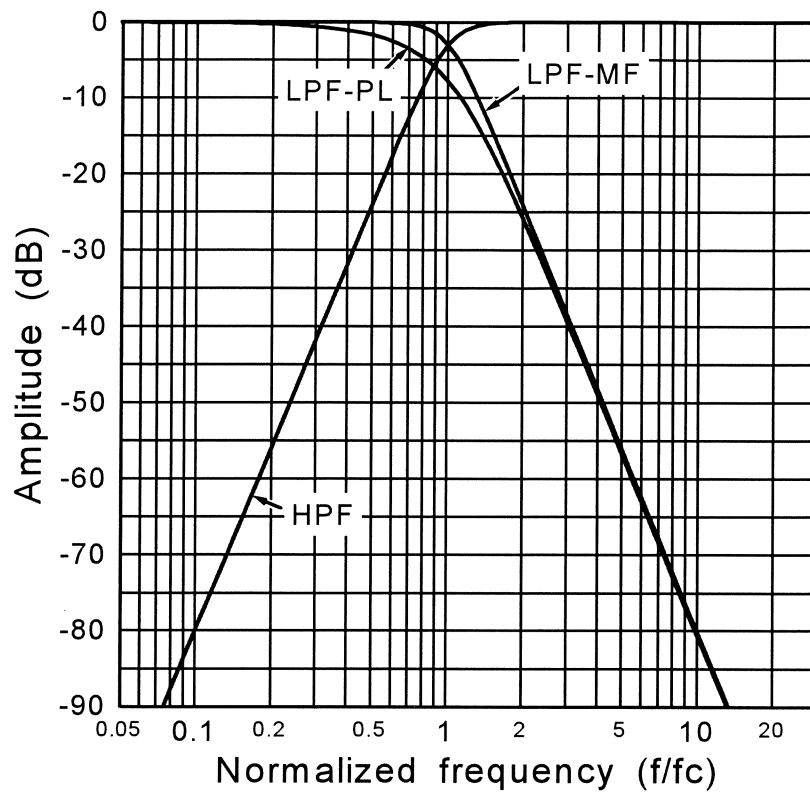

Fig. 5.1 Amplitude Response

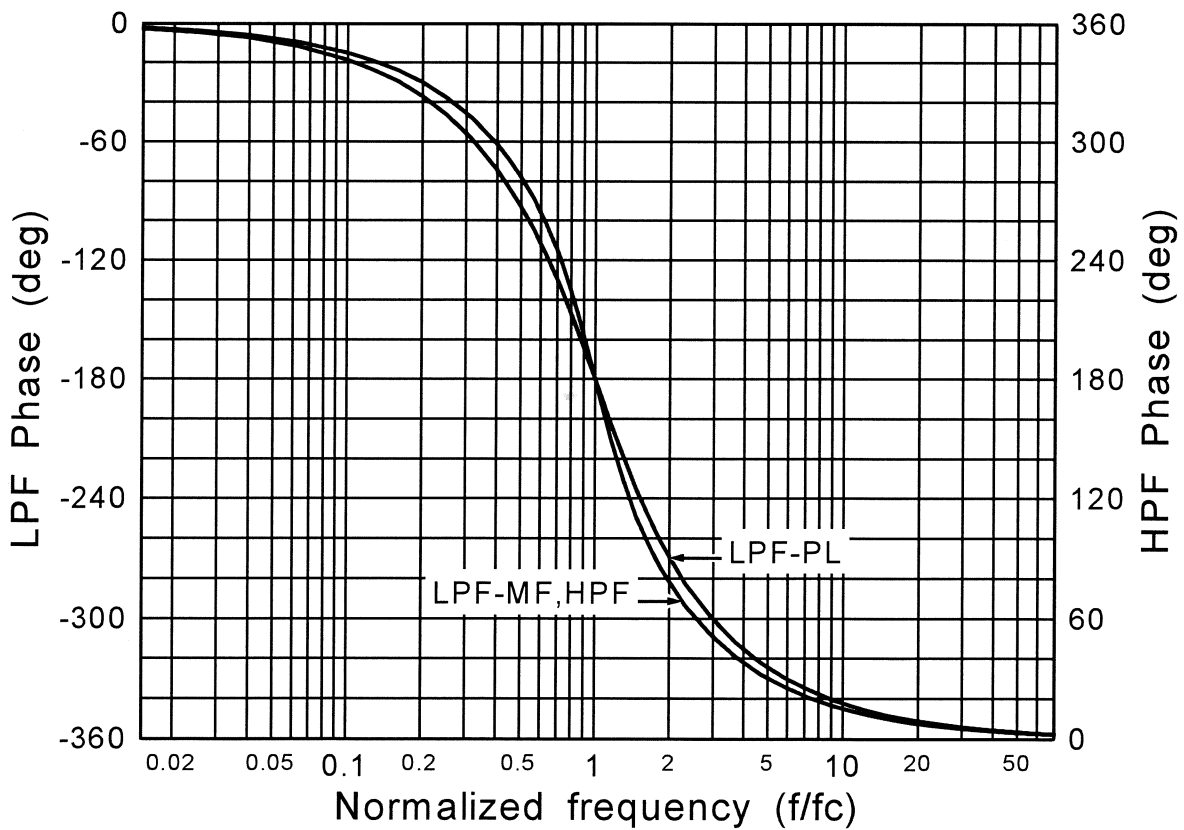

Fig. 5.2 LOW-PASS & HIGH-PASS FILTER Phase Response

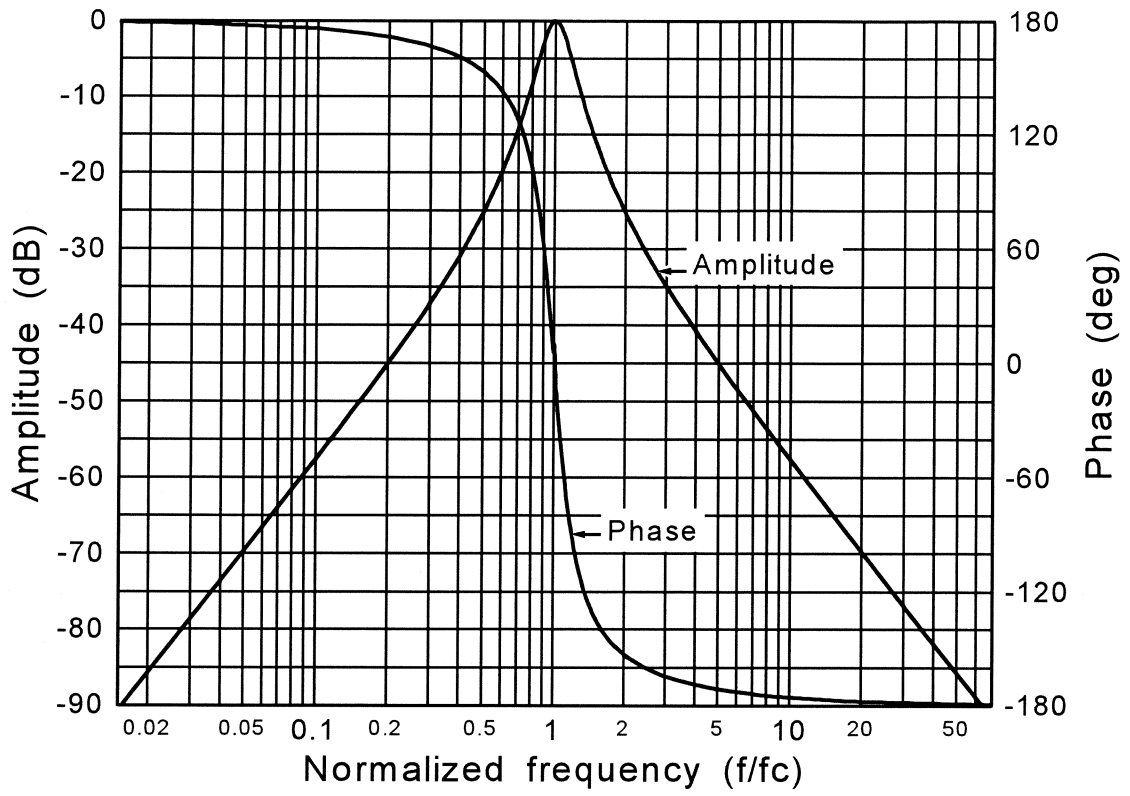

Fig. 5.3 BAND-PASS FILTER Amplitude & Phase Response

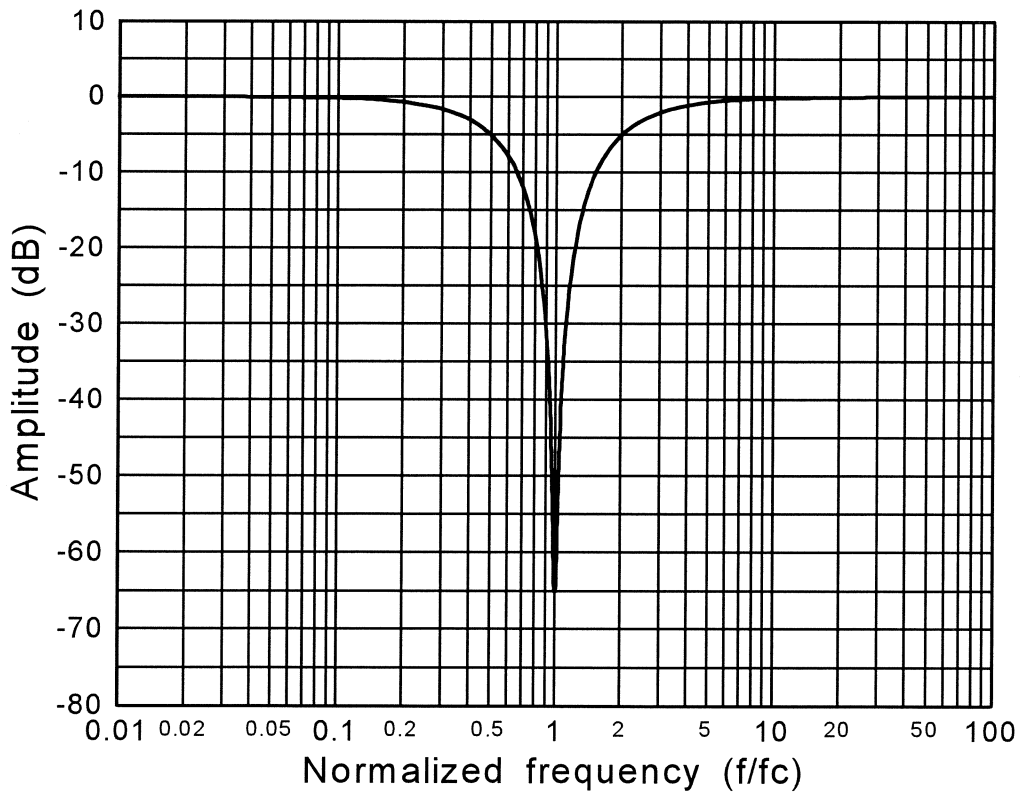

Fig. 5.4 BAND-ELIMINATION FILTER Amplitude Response

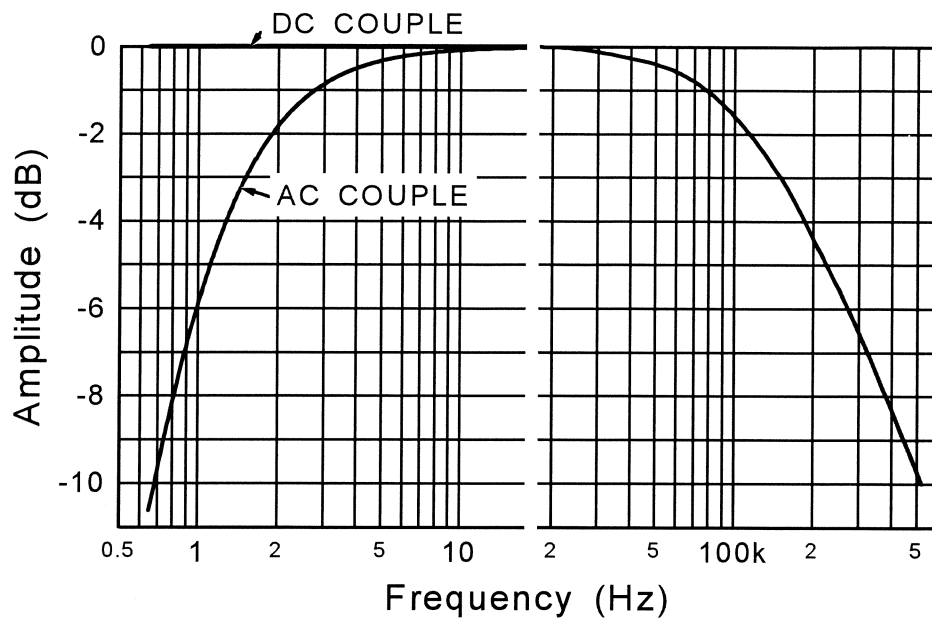

Fig. 5.5 THRU Amplitude Response

Section 6 Specifications

Notes: “f” indicates input frequency, and “fc” and “fo” indicates setting frequency.

6.1 Filter section

■ Functions

THRU	Through	
LPF-MF	4th order maximally flat low-pass filter	-24 dB \pm 2 dB/oct (typical)
LPF-PL	4th order phase linear low-pass filter	
HPF	4th order high-pass filter	-24 dB \pm 2 dB/oct (typical)
BPF	Band-pass filter	Bandwidth = 1/3 oct, Q=4.3 (typical)
BEF	Band-elimination filter	

■ Frequencies

0.1 Hz to 21.8 kHz

Set by 2 decade dials and a 5 step multipliers.

■ Pass band gain

0 dB/20 dB selectable

■ Pass band gain error (both 0 dB and 20 dB)

LPF-MF($f \leq 0.5 f_c$)	± 0.5 dB
LPF-PL($f \leq 0.1 f_c$)	± 0.5 dB
HPF($2 f_c \leq f \leq 50$ kHz)	± 0.5 dB
($2 f_c \leq f \leq 100$ kHz)	+0.5 dB/-3 dB
THRU($f \leq 100$ kHz)	+0.5 dB/-3 dB

■ Gain at setting frequency

LPF-MF	-3 dB \pm 1 dB	(0 dB is the gain at 1/2 of setting frequency)
LPF-PL	-8.4 dB \pm 1 dB	(0 dB is the gain at 1/10 of setting frequency)
HPF	-3 dB \pm 1 dB	(0 dB is the gain at twice of setting frequency)
BPF	0 dB \pm 1.2 dB	(0 dB is the gain at THRU mode)
BEF	less than -40 dB	(0 dB is the gain at 1/10 of setting frequency)

■ Maximum attenuation

Less than 80 dB (at DC to 1 MHz)

6.2 Input section

■ Number of channels

1 channel

■ Connector

BNC-receptacle, single ended

■ Coupling

AC/DC selectable (AC coupling: approx. -3 dB at 1.6 Hz)

■ Input impedance

Resistance: $1\text{ M}\Omega \pm 2\%$ (DC)

Capacitance: Less than 50 pF

■ Maximum input voltage (linear operation)

$\pm 10\text{ V}$ at GAIN 0 dB

$\pm 1\text{ V}$ at GAIN 20 dB

6.3 Output section

■ Connector

BNC-receptacle, single ended

■ Output impedance

$50\ \Omega \pm 10\%$

■ Maximum output voltage (linear operation)

$\pm 10\text{ V}$ /no-load.

■ Maximum output current (linear operation)

$\pm 20\text{ mA}$

6.4 Amplifier section

■ Distortion factor

Less than 0.07 % (10 Hz to 20 kHz, at pass band and ± 10 V output)

■ Output noise

Less than 0.3 mVrms (Bandwidth=500 kHz)

■ Output DC offset

Adjustable to 0 V

■ Output DC offset drift

0.3 mV/°C (typical) at GAIN 0 dB

1.2 mV/°C (typical) at GAIN 20 dB

6.5 General

■ Line voltage

AC 100 V, 120 V, 220 V or 240 V ± 10 % (250 V max)

■ Line frequency

50/60 Hz

■ Power consumption

Less than 6 VA

■ Isolation resistance

More than 30 M Ω (DC 500 V, between line and chassis)

■ Withstand voltage

AC 1500 V, 1 minute (between line and chassis)

■ Environment

Operating: 0 °C to 40 °C, 10 %RH to 90 %RH (non-condensation)

Storage: -10 °C to 50 °C, 10 %RH to 80 %RH (non-condensation)

■ Dimensions

216 (W) x 132.5 (H) x 290 (D) mm (excluding protrusions)

216 (W) x 151 (H) x 319 (D) mm (including protrusions)

■ Weight

Approx. 2.6 kg (net)

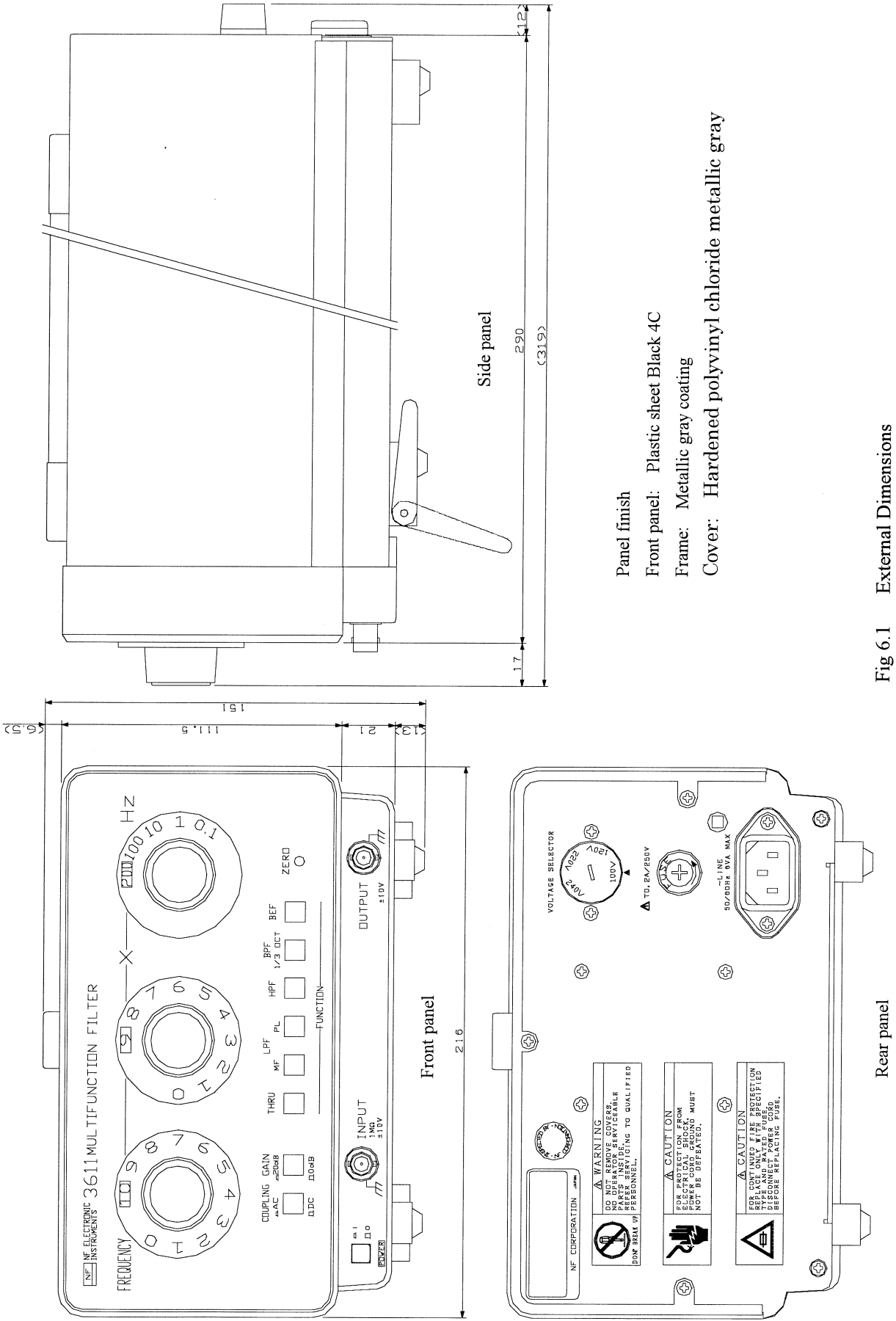

Panel finish
 Front panel: Plastic sheet Black 4C
 Frame: Metallic gray coating
 Cover: Hardened polyvinyl chloride metallic gray

Fig 6.1 External Dimensions

WARRANTY

NF CORPORATION certifies that this instrument was thoroughly tested and inspected and found to meet its published specifications when it was shipped from our factory.

All **NF** products are warranted against defects in materials and workmanship for a period of one year from the date shipment. During the warranty period of, **NF** will, at its option, either will repair the defective product without any charge for the parts and labor, or either repair or replace products which prove to be defective. For repair service under warranty, the product must be returned to a service center designated by **NF**. Purchaser shall be prepay shipping charge, duties, and taxes for the product to **NF** from another country, and **NF** shall pay shipping charge to returned the product to purchaser.

This warranty shall not apply to any defect, failure or damage caused by improper use, improper or inadequate maintenance and care or modified by purchaser or personnel other than **NF** representatives.

NF CORPORATION

If there are any misplaced or missing pages, we will replace the manual. Contact the sales representative.

NOTES

- Reproduction of the contents of this manual is forbidden by applicable laws.
- The contents of this manual may be revised without notice.
- Information provided in this manual is intended to be accurate and reliable. However, we assume no responsibility for any damage regarding the contents of this manual.
- We assume no responsibility for influences resulting from the operations in this manual.

Copyright 1998, **NF CORPORATION**

3611 MULTIFUNCTION FILTER Operation Manual

NF CORPORATION

3-20 Tsunashima Higashi 6-chome, Kohoku-ku. Yokohama-shi
223-8508, JAPAN

Phone (045) 545-8111 Fax (045) 545-8191 Telex 3823-297

