



CD PLAYER EVALUATING FILTER

**3346A**

---

INSTRUCTION MANUAL



D:508464

**3 3 4 6 A**  
**CD PLAYER EVALUATING FILTER**  
**I N S T R U C T I O N**  
**M A N U A L**



## WARRANTY

*NF CORPORATION* certifies that this instrument was thoroughly tested and inspected and found to meet its published specifications when it was shipped from our factory.

All *NF* products are warranted against defects in materials and workmanship for a period of one year from the date shipment. During the warranty period of, *NF* will, at its option, either will repair the defective product without any charge for the parts and labor, or either repair or replace products which prove to be defective. For repair service under warranty , the product must be returned to a service center designated by *NF*. Purchaser shall be prepay shipping charge, duties, and taxes for the product to *NF* from another country, and *NF* shall pay shipping charge to returned the product to purchaser.

This warranty shall not apply to any defect, failure or damage caused by improper use, improper or inadequate maintenance and care or modified by purchaser or personnel other than *NF* representatives.

*NF CORPORATION*



## FOREWORD

Thank you very much for procuring the 3346A CD Player Evaluating Filter. At the outset, please take a few minutes to read the Safety Precautions indicated in this manual in order to use this equipment safely and correctly.

- Warning and Caution notices

The following Warning and Caution notices appear in this manual. These must be observed in order to protect both the user from physical harm and the equipment from damage.

**⚠ WARNING**

Risk of serious and possibly fatal injury from electric shock or other cause.

**⚠ CAUTION**

Risk of damage to the equipment.

## SAFETY PRECAUTION

Observe the following warnings and cautions in order to use this equipment safely. No responsibility or warranty is assumed for damages arising from use in a manner contrary to these warnings and cautions.

- Observe text instructions

This manual has been compiled in order to enable safe operation and use of this equipment. Be sure to read this manual before using the equipment.

Items designated by Warning advise of serious physical hazards. Be sure to observe these carefully.

- Be sure to connect ground

Since the unit includes a built-in line filter, there is risk of shock if used without grounding. Be sure to properly connect the ground. By connecting the 3 conductor power cable to a grounded 3-terminal wall socket, the equipment is automatically grounded.

- Confirm power source voltage

Before connecting this equipment, check that the proper voltage is being supplied to the power outlet. Refer to the Grounding and Power Supply section of this manual.

- Use only the properly rated fuse

Improperly rated fuses present a fire hazard and other risks. Refer to the name and operating each section of this manual and confirm the fuse rating.

Be sure to disconnect the equipment from the power source before replacing the fuse.

- Smoke, odor, noise

In event smoke, peculiar odor or noise is emitted, immediately disconnect the power source and avoid and further operation. Contact service.

- Flammable gas

Do not use this equipment in the presence of flammable gas. There is danger of fire and explosion.

- Do not remove the covers

This equipment contains high voltages. Do not remove external covers.

Refer all internal inspection and service to a qualified service technician who fully understands the hazards.



- Do not modify

Do not use parts other than specified by the manufacturer and by no means attempt to modify the equipment. There is risk of personnel hazard and damage to the equipment. The manufacturer reserves the option of refusing service in such cases.

- Safety related symbols and indications

Following are general definitions of the symbols and indications used in the text on the product.



Advises of possible hazard to the user, as well as the need to consult this manual when using an operation or function.

 WARNING

Appears in the text and on the product to advise risk of fatal or otherwise serious physical injury.

 CAUTION

Appears in the text and on the product to advise risk of damage to product.



# CONTENTS

	Page
• Foreword-----	I
• Safety Precautions-----	II
• Section 1 Introduction-----	1
1-1 Outline -----	1
1-2 Measuring items and internal connection-----	1
1-3 Specifications-----	2
1-4 Function of each section-----	4
1-5 Block diagram-----	5
• Section 2 Preparation for use-----	8
2-1 Safety check-----	8
2-2 Unpacking and repacking -----	8
2-3 Configuration-----	8
2-4 Location -----	8
2-5 Grounding and power source-----	9
• Grounding-----	9
• Power source -----	9
• Line filter-----	9
• Section 3 Operating instruction-----	10
3-1 Name and operating each section-----	10
3-2 How to operate-----	12
3-2-1 Power on-----	12
3-2-2 Selection of measuring channel-----	12
3-3 Notes for operations-----	13
• Section 4 Maintenance-----	16
• Section 5 Standard data-----	17

CHART
-------

	Page
Fig. 1-1 Block diagram-----	6
Fig. 1-2 External drawing-----	7
Fig. 3-1 The way of replacing a fuse-----	11
Fig. 3-2 Pin assignment-----	11
Fig. 3-3 Panel description-----	15
Fig. 5-1 IEC-651-A amplitude response-----	17
Fig. 5-2 Low pass filter amplitude response-----	17
Fig. 5-3 Amplitude response of the serial connection of Low pass and IEC-651-A filters-----	18
Table 2-1 Configuration list-----	8

# 1. INTRODUCTION

## 1-1 OUTLINE

The 3346A is a low pass filter used for measuring a CD player.

The Standard CP-307 "The measuring ways of a CD player" of EIAJ recommends the usage of a low pass filter for each measurement of signal vs. noise ratio, dynamic range, total harmonic distortion, channel separation and cross modulation distortion.

The 3346A has low pass filter built-in with sharp cut-off response, low noise and low distortion ratio, and a 60dB amplifier and weighting network built-in which are needed for measuring a dynamic range to fit these measurements. These functions are selected by a selection switch of measurement item.

The internal circuit is one channel and there are two-channel input terminals. The L/R channel is selected by a switch.

There are a rear panel connector which enables the switching by an external signal same as that via front panel push buttons.

The power supply voltage of the 3346A is AC100V or either of 120V or 230V. According to the power supply voltage, turn the power supply voltage selection switch.

## 1-2 MEASURING ITEMS AND INTERNAL CONNECTION

The selected measurement item by a push button on front panel and internal connection status are as follows.

(1)THRU(Through)

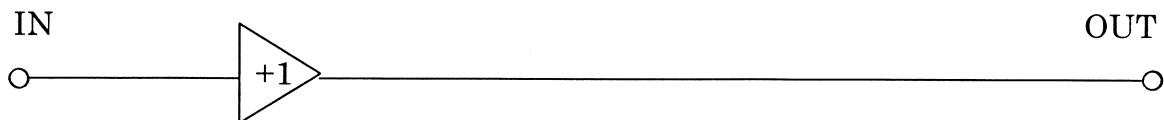

(2)S/N(Signal vs. noise)

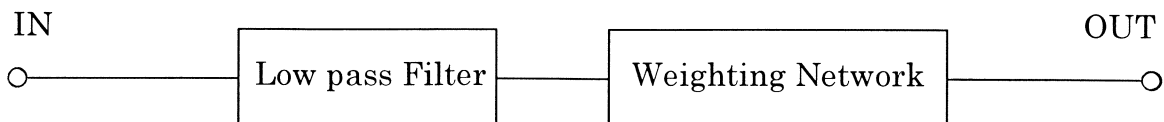

(3)DIST(Total harmonic distortion, cross modulation distortion factor)

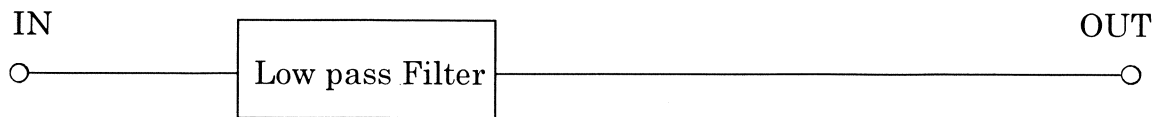

(4)CH-SEP(Channel separation)

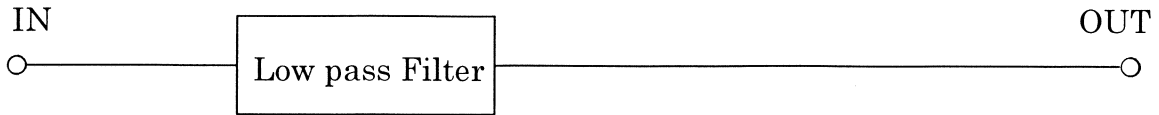

(5)D-RANGE(Dynamic range)

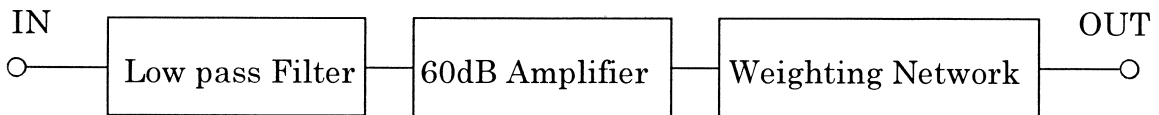

(6)MON(Low pass filter + 60dB amplifier)

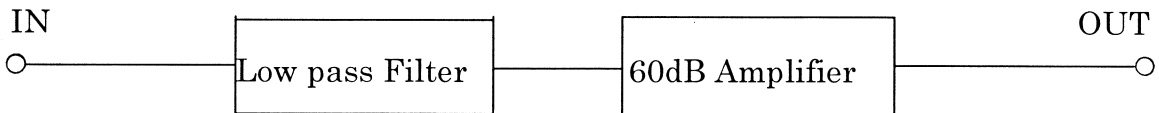

- The low pass filter is a 9th-order Unified Chebyshev with a cut off frequency of 20kHz.
- The weighting network is A curve prescribed by IEC Publ. 651, deviation of type 0.
- The MON is used to monitor a distorted wave form.

### 1-3 SPECIFICATIONS

Measurement Items	<u>THRU</u>	<u>S/N</u>	<u>DIST</u> <u>CH-SEP</u>	<u>D-RANGE</u>	<u>MON</u>
Internal Configuration	—————	Low pass filter + Weighting network	Low pass filter	Low pass filter + 60dB amplifier + Weighting network	Low pass filter + 60dB amplifier
Max. input voltage	±15V				
Load resistor	10k Ω				
Input CH Number	1 (To be L/R channel switched)				
Input Impedance	1M Ω/10k Ω (single-ended, to be switched)				

Output Impedance	100 $\Omega$ or less (single-ended)					
Input Voltage	2Vrms			2mVrms		
Low pass Filter Cutoff Frequency	_____	20kHz (Nominal Value)				
Pass band Gain at 1kHz	0 $\pm$ 0.1dB	0 $\pm$ 0.2dB		60 $\pm$ 0.2dB		
Attenuation in high F range	_____	60dB or more (24.1kHz to 1MHz)				
Attenuation in low F range	_____	According to IEC-651-A	DC Pass	According to IEC-651-A	6dB/oct. -3dB at 4Hz	
Pass band Ripple DC to 20kHz	_____		Within 0.2dBp-p	_____		
Dist. Factor	at 1kHz	0.0005% or less 0.0004% typ.	0.0014% or less 0.0007% typ.	0.0008% or less 0.0006% typ.	0.5% or less 0.3% typ.	1% or less 0.5% typ.
	※1 at 20kHz	0.0015% or less 0.0010% typ.	0.0023% or less 0.0017% typ.	0.0011% or less 0.0008% typ.	1% or less 0.5% typ.	0.7% or less 0.3% typ.
Noise Level 10Hz to 500kHz	5 $\mu$ Vrms or less 4 $\mu$ Vrms typ.	8 $\mu$ Vrms or less 5.6 $\mu$ Vrms typ.	12 $\mu$ Vrms or less 9.2 $\mu$ Vrms typ.	6mVrms or less 5mVrms typ.	13mVrms or less 10mVrms typ.	
S/N For 2Vrms Output	112dB or more 114dB typ.	108dB or more 111dB typ.	104dB or more 107dB typ.	_____		
CH-SEP ※2	100dB or more, 110dB typ.			_____		
Measurement Item Selection	By Front Panel Push Buttons or External Control					
Ambient Temp. and Humidity range	Operating 0 to 40°C, 10 to 80% RH no condensation Storage -10 to 50°C, 10 to 80% RH no condensation					
Power Requirements	AC100V/120V/230V $\pm$ 10%, 50Hz/60Hz, 15VA max.					
Insulation and Withstanding	Power input lines vs. chassis 50M $\Omega$ or more (DC 500V) AC 1500V, for 1 minute					
Weight	3.1kg approx.					

Dimensions	215(W)×88(H) ×300(D)mm (Excluding Protrusions)
------------	--

※1 Reference: Filter 80kHz/IN, Input voltage / 2Vrms output of 1kHz in THRU.

※2 Reference: Crosstalk (up to 20kHz) of R→L and L→R / 2Vrms

#### 1-4 FUNCTION OF EACH SECTION

##### (1) Input channel selection switch

Select either L or R channel. The channel with a LED lit is connected to the internal circuit.

##### (2) Input terminal(L and R)

The output of a CD player is to be connected to each channel terminal.

##### (3) Input impedance selection switch

Switches the input impedance to 1M  $\Omega$  or 10k  $\Omega$ . This 10k  $\Omega$  is the load impedance specified by “CP-307, the measuring way of a CD player”.

##### (4) Item selection switch

Select the specified item. The internal connecting configuration of a low pass filter, a 60dB amplifier and weighting network is changed by this switch. The selected item is indicated by a LED lit.

##### (5) Output terminal

The two BNC terminals are connected in parallel. This is convenient when some units are connected.

##### (6) Power switch

This unit is powered on with a LED lit by turning the switch on.

##### (7) External control connector

This connector is used when input channel and measurement item are to be selected by an external signal. This connector is a 24-pin multi-connector and installed on rear panel.

##### (8) Power supply voltage selection switch

According to the power supply voltage, turn the switch AC100V or either of 120V or 230V.



## 1-5 Block diagram

The block diagram of the 3346A is as follows.

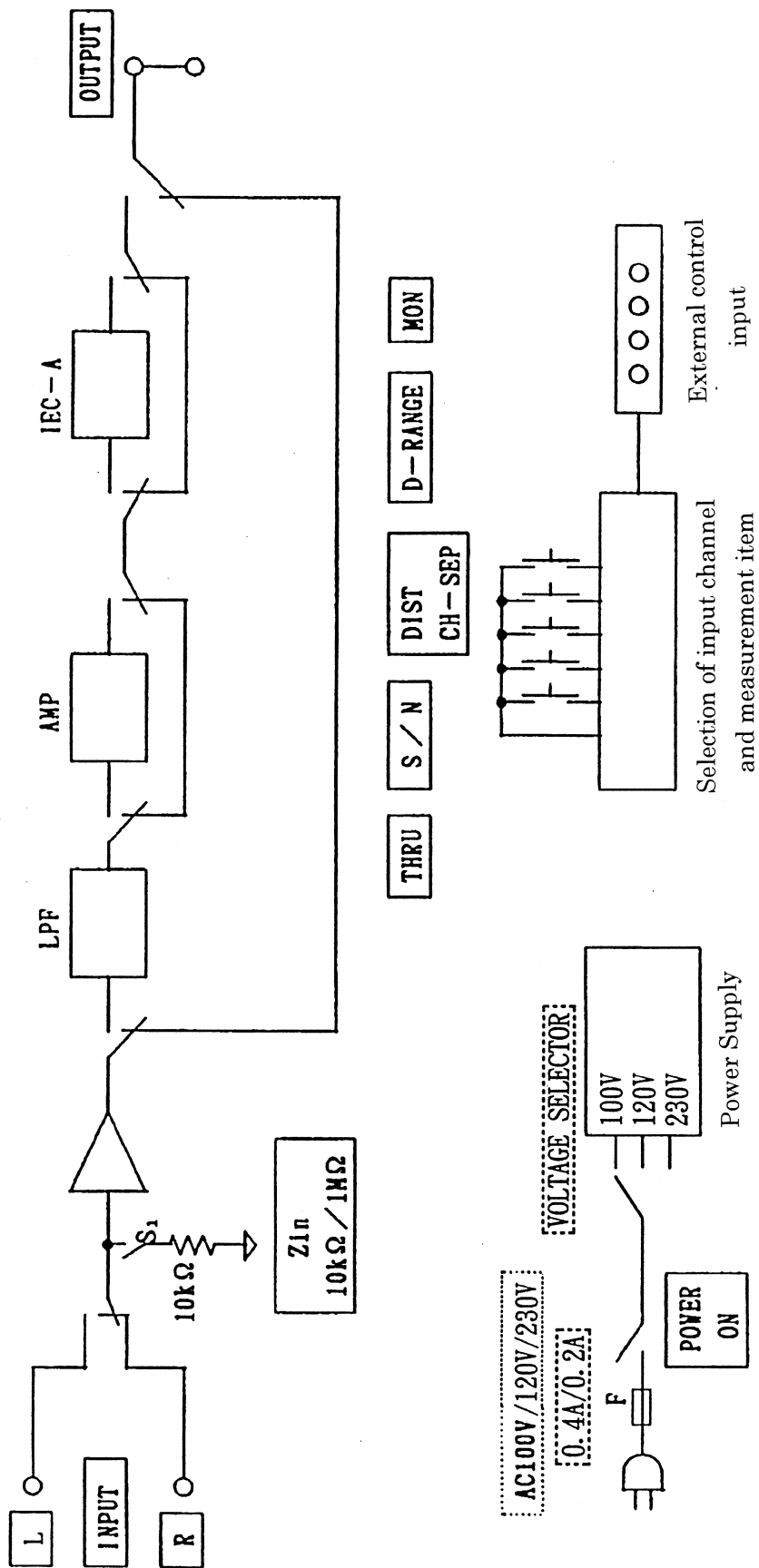

Fig. 1-1 Block diagram

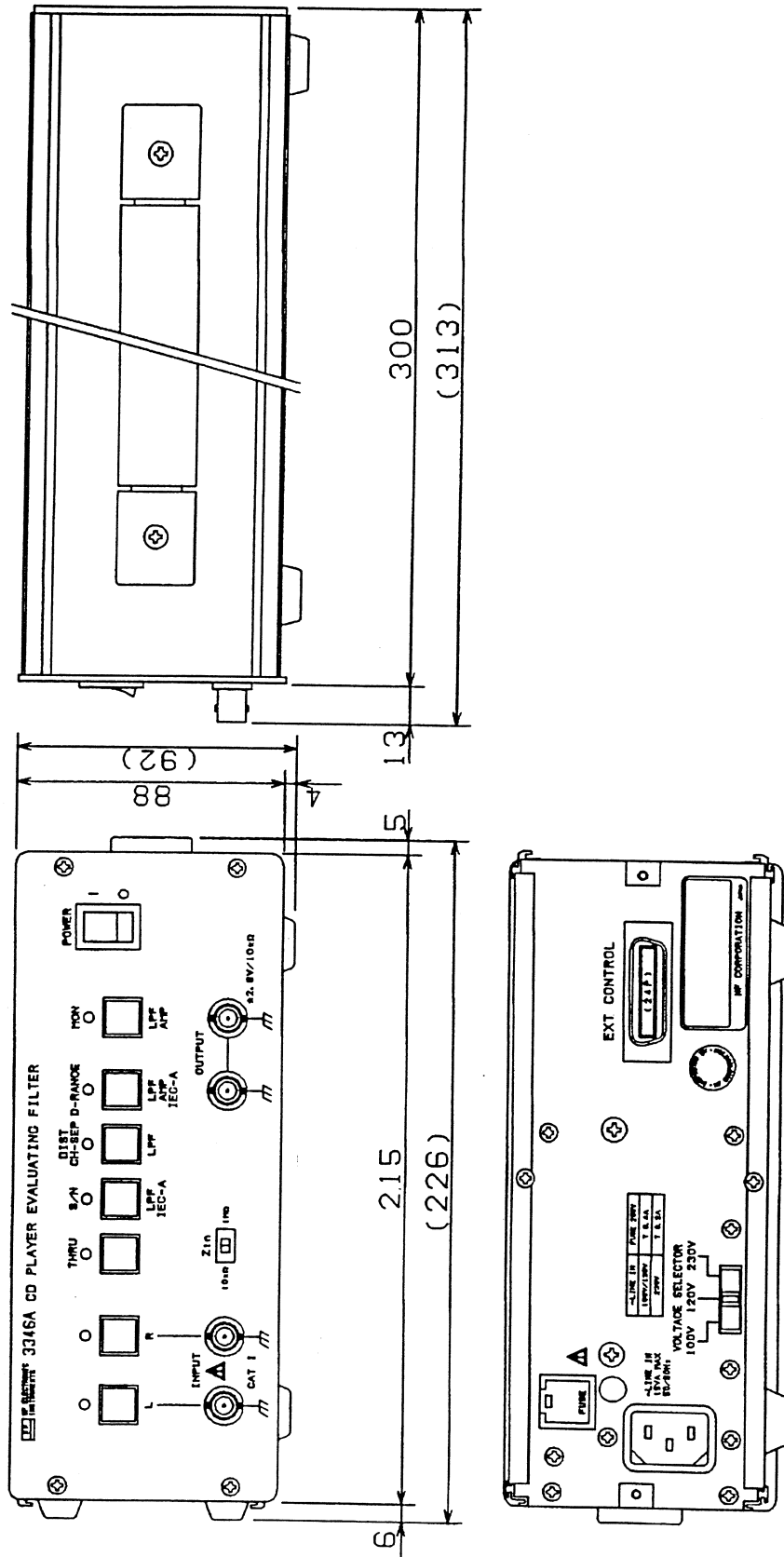

Fig 1-2 External drawing

**2. PREPARATION FOR USE**

**2-1 SAFETY CHECK**

Before using the 3346A, refer to the Safety precautions of this manual and confirm safety.

**⚠ WARNING**

Do not remove the covers.  
This equipment contains dangerously high voltages. Do not remove external covers. Refer all internal inspection and service to a qualified service technician who fully understands the hazards.

**2-2 UNPACKING AND REPACKING**

**(1)Unpacking**

After unpacking, check for any damage which may have been caused during transportation. Also check any shortage of accessories referring to 2-1 Configuration.

**(2)Repacking**

When repacking the instrument for transportation, prepare a carton with proper strength and size and filters to protect the instrument appropriately.

**2-3 CONFIGURATION**

Table 2-1 lists the configuration list of the instrument.

Table 2-1 Configuration list

Main frame	1
Instruction Manual	1
Supplied accessories	
Power cable:(3-conductors, 2meters)	1
Fuse           :(100V/120V: 0.4A or 230V: 0.2A)	
Time lag, 250V, $\Phi$ 5.2×20mm)	1

**2-4 LOCATION**

The tolerable ambient temperature and humidity ranges of the instrument are as follows. Moisture condensation must be absent.

Operating	0 to 40°C, 10 to 80% RH
Storage	-10 to 50°C, 10 to 80% RH

Avoid installing the equipment in the following types of locations.

- Flammable gas

Do not use this equipment in the presence of flammable gas. There is danger of fire

and explosion.

- In direct sunlight, near fire or heat source

It may cause some failure or error.

- Corrosive gas, moisture, dust or high humidity

It may cause the equipment corroded or some failure.

- Strong magnetic or electromagnetic fields

It may cause some error.

- Strong vibration

It may cause some failure or error.

## 2-5 GROUNDING AND POWER SOURCE

- Grounding

### WARNING

This equipment must be grounded in order to prevent electric shock accidents.

Confirm the protective ground terminal is connected to ground before connecting the equipment for measurements. The 3346A protective ground is connect to ground by the 3-prong power supply plug.

Use the supplied power supply cable to connect to a 3-terminal power outlet that has a protective ground contact.

- Power source

### CAUTION

Be sure to observe the following in order to prevent damage to the equipment.  
Confirm the power source voltage is within the range specified for the 3346A.

The 3346A operates from the following commercial power source.

Power supply voltage range: AC100V/120V/230V $\pm$ 10%

Power supply frequency range: 50Hz/60Hz

Power consumption: MAX.15 VA

- Line filter

A line filter circuit is used in the 3346A.

Maximum leakage current at 250V is 0.5mArms. Since there is risk of electric shock by touching metal parts, in the interest of safety , be sure to ground the equipment

## 3. OPERATING INSTRUCTION

### 3-1 NAME AND OPERATION EACH SECTION

① \_\_\_\_\_ Input channel select switch

Select either of L or R channel. The channel with LED lit is connected to the internal circuit.

② \_\_\_\_\_ Measurement item

This switch is to select the specified item. The internal connecting configuration will be changed. The selected item is indicated by LED lit.

③ POWER I/O Power switch

The unit is powered on with LED lit by turning the switch on.

④ INPUT Internal terminal

The output of CD player is to be connected to each R and L input terminal.

⚠ CAUTION

Do not apply a signal exceeding  $\pm 15V$  to the input terminal . It may cause some failure.

In D-Range or MON mode, set the input signal level to 3.5Vrms or less, because the circuit has 60dB gain in the pass band. When the level is too high, a correct measurement may not be performed.

⑤ Zin Input impedance

Switches the input impedance to 1M  $\Omega$  or 10k  $\Omega$  . This 10k  $\Omega$  is the load impedance specified by CP-307 "The measuring ways of a CD player".

⑥ OUTPUT Output terminal

The two BNC terminals are connected in parallel. This is convenient when some other units are connected.

⚠ CAUTION

Do not apply any signal source to the output terminal of the 3346A. It may cause some failure.

⑦ FUSE Fuse holder

This holds a time lag, 250V fuse inside.

The ways of replacing a fuse are as follows.

Specified rating of a fuse of the 3346A are as follows.

AC100V/120V: 0.4A

AC230V : 0.2A

Time lag, 250V,  $\Phi$  5.2 × 20mm

According to the power supply voltage, specified rating of a fuse differs.

**⚠ WARNING**

Use only a fuse with the specified rating.

There is risk of fire from an improperly rated fuse. Be sure to disconnect the power cord before replacing the fuse.

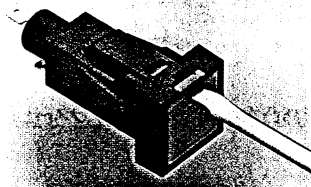

replacing a fuse frontally

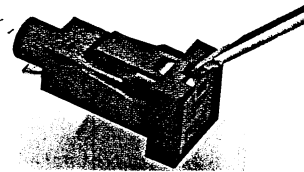

replacing a fuse from above

Fig. 3-1 The way of replacing a fuse

⑧ EXT CONTROL External control connector

This connector used when input channel and measurement item are to be selected by an external signal. This control signal is TTL level compatible one with an negative-logic. For each pin number , refer to the “Figure 3-1 Pin assignment”.

The plug type is Amphenol 57-30240.

24	N.C.	12	N.C.
23	N.C.	11	N.C.
22	N.C.	10	N.C.
21	N.C.	9	N.C.
20	N.C.	8	N.C.
19	GND	7	MON
18	GND	6	D-RANGE
17	GND	5	DIST
16	GND	4	S/N
15	GND	3	THRU
14	GND	2	L
13	GND	1	R

Fig. 3-2 Pin assignment

⚠ CAUTION

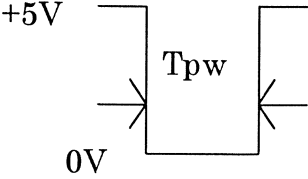

The external control signal should be a pulse or contact signal as above.  
 $T_{pw} \geq 200 \mu \text{ sec}$

⑨ \_\_\_\_\_ Power receptacle

This is to be connected by the power cord.

⑩ VOLTAGE SELECTOR Power supply voltage selection switch

According to the power supply voltage, turn the switch AC100V or either of 120V or 230V.

⑪ \_\_\_\_\_ Inspection clearance certifying label

This label is to certify that this unit satisfies the published specifications and our quality standard, and that has passed our inspection.

⑫ \_\_\_\_\_ Serial No. label

Indicates the unit's serial number.

## 3-2 HOW TO OPERATE

### 3-2-1 Power on

After confirming that the power supply voltage according to the actual main voltage, turn the power switch on. The unit will be set to the following when powered on.

Input : L

Measurement item: THRU

### 3-2-2 Selection of measuring channel

#### (1) Switching of measuring channel

- L

The channel to be connect to the inside is set to INPUT L.

- R

The channel to be connect to the inside is set to INPUT R.



- Zin

This is to switch the input impedance. It is set to 10k  $\Omega$  or 1M  $\Omega$  when turning this slide switch to the left side or right side. The EIAJ CP-307 specifies 10k  $\Omega$  for the load impedance. The 1M  $\Omega$  is prepare for much wider application.

(2) The measurement item of the 3346A include the following five ones:

- THRU

The input is output via a buffer amplifier. The input impedance accords the value selected by the impedance selection switch, and the output is in the same phase with a gain of 1.

- S/N

Set this when measuring a S/N ratio. The inside is configured with a low pass filter and weighting network.

- DIST CH-SEP

Set this when measuring distortion factor and channel separation. This is configured with only a low pass filter.

- D-RANGE

Set this when measuring dynamic range. This is configured with a low pass filter, 60dB amplifier and weighting network. (Refer to EIAJ CP-307)

- MON

A low pass filter and a 60dB amplifier are connected to inside. This is used to monitor the wave form, etc.

### 3-3 NOTES FOR OPERATION

**⚠ WARNING**

In event smoke, peculiar odor or noise is emitted, immediately disconnect the power source and avoid and further operation.

**⚠ CAUTION**

The CD-measurement equipment is a very sensitive unit, therefore we strongly request the user not to use this equipment nearby radio disturbances sending equipment.

Please make sure not to use the equipment in areas where such problems occur.

Since the unit is provided to be built inside a portable rack, it has mounting holes for this purpose, if you do not need to install it we would like to ask you to close this holes in order to avoid EMC disturbance to this measurement appliance. It is an class A equipment.

Should you recognize problems please contact the local distributor for help and advice.

It may be one solution to ground the frame additionally if this unit is used under built in condition in an measurement rack for example.

As a general safety request we strongly ask the end user to assure that each person who operates this unit has read and understood the instruction manual and confirmed this with a signature.

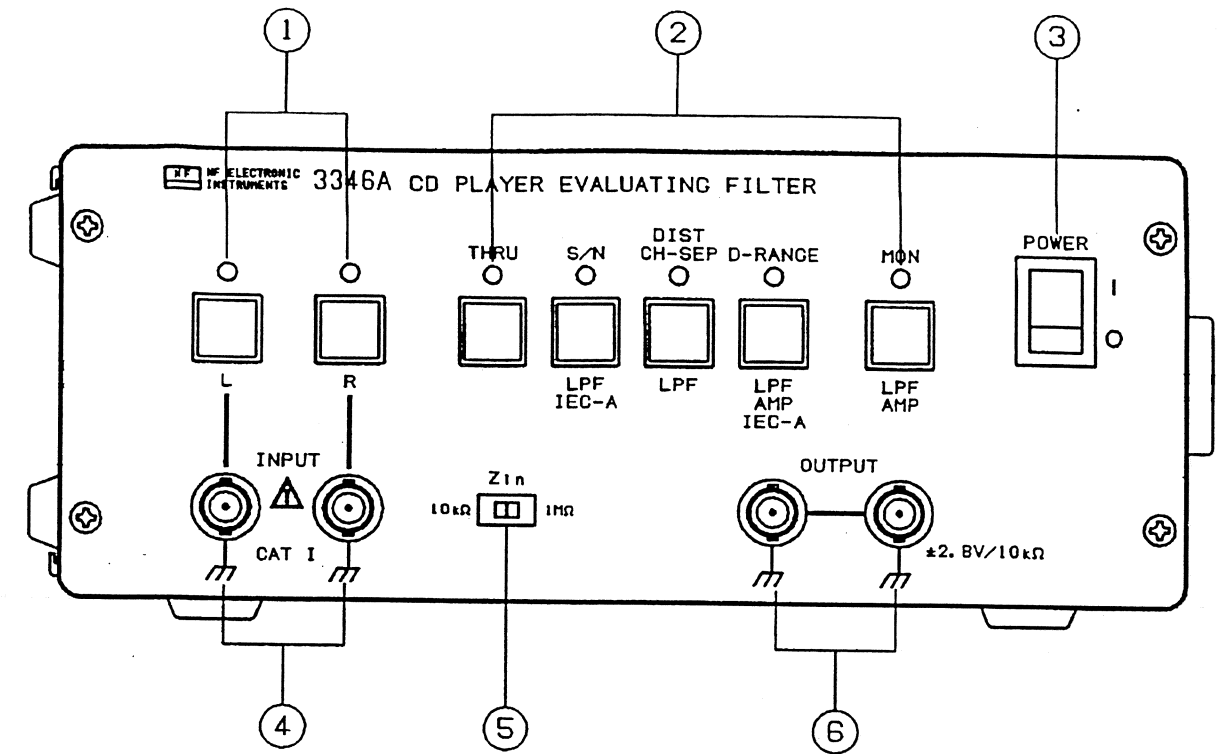

Front panel

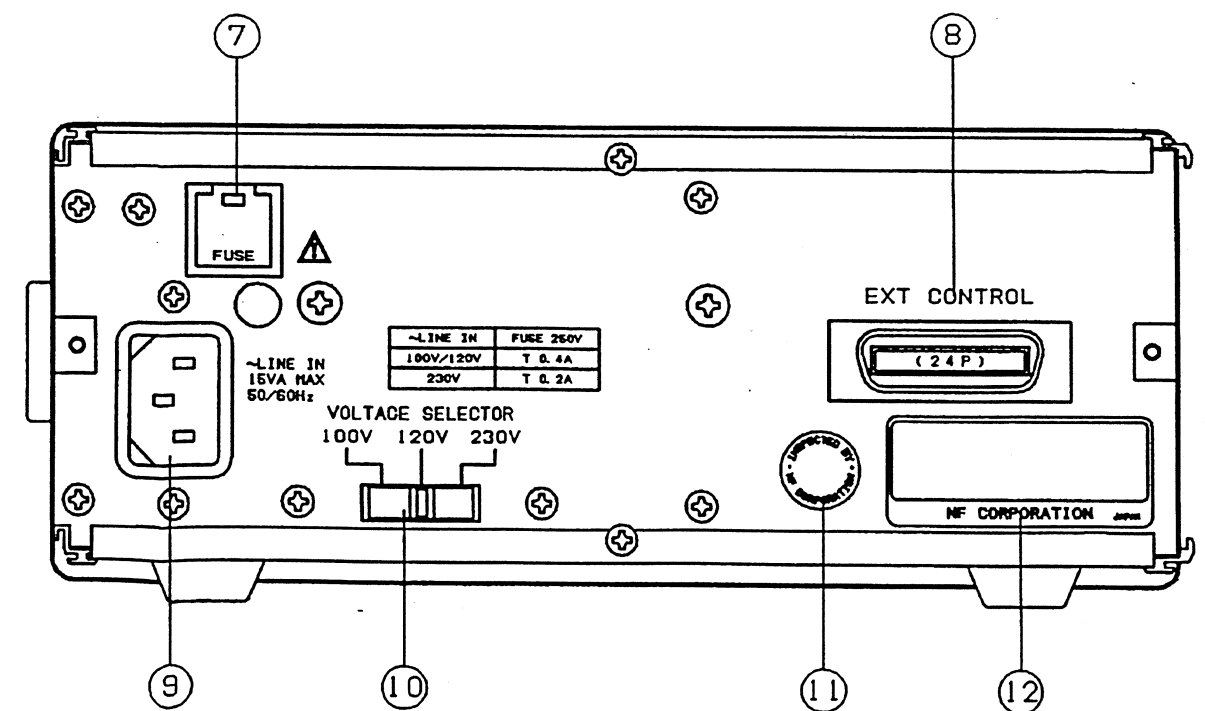

Rear panel

Fig. 3-3 Panel description



## 4. MAINTENANCE

### WARNING

Only use a fuse with the specified rating. There is risk of fire from an improperly rated fuse.

Be sure to disconnect the power cord before replacing the fuse.

In case that a fuse blows again after the replacement, disconnect the power cord from the mains and contact our sales network.

Specified rating of a fuse of the 3346A are as follows.

AC100V/120V: 0.4A

AC230V : 0.2A

Time lag, 250V,  $\Phi$  5.2 × 20mm

According to the power supply voltage, specified rating of a fuse differs.

Trimmers on the printed circuit board have been adjusted before shipment. Please leave re-adjustment to the authorized engineers of *NF CORPORATION*.

Contact our sales network regarding calibration and repair.

## 5. STANDARD DATA

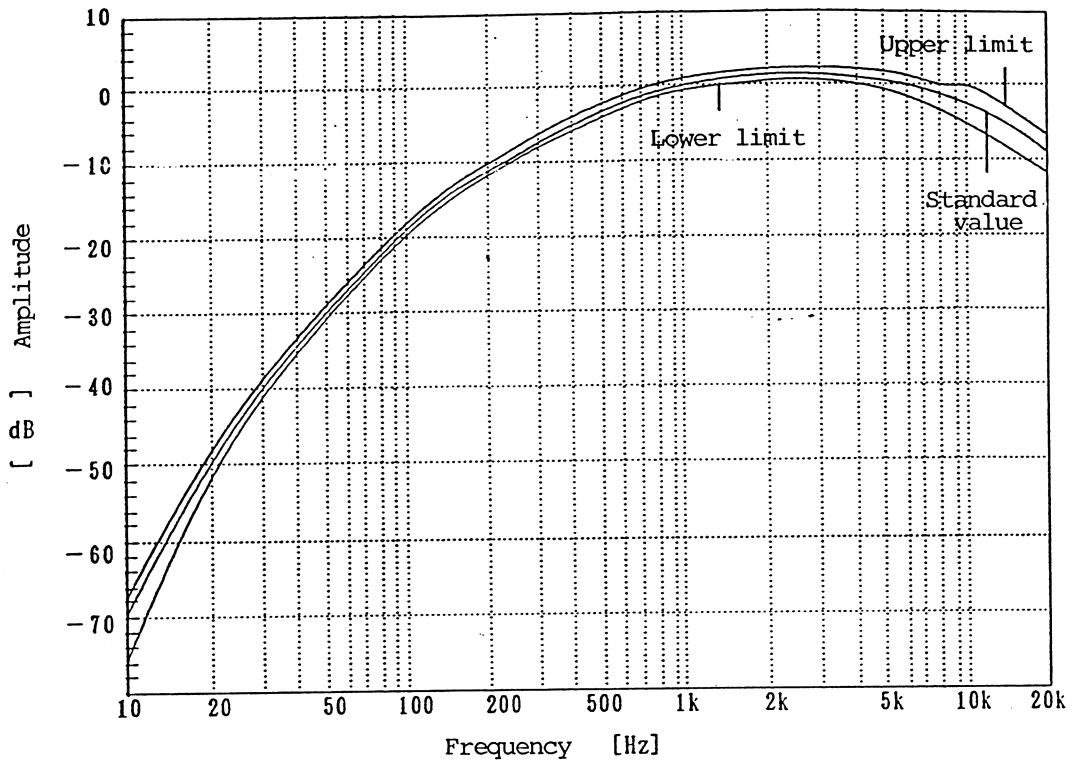

Fig. 5-1 IEC-651-A Amplitude response

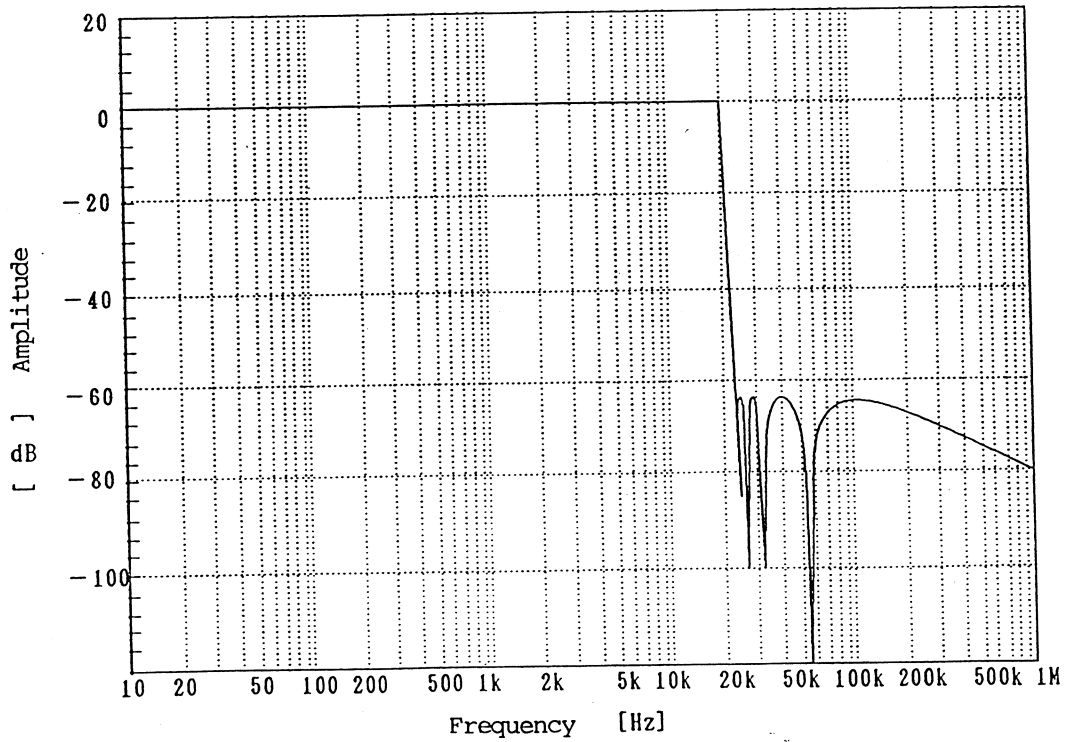

Fig. 5-2 Low pass filter Amplitude response

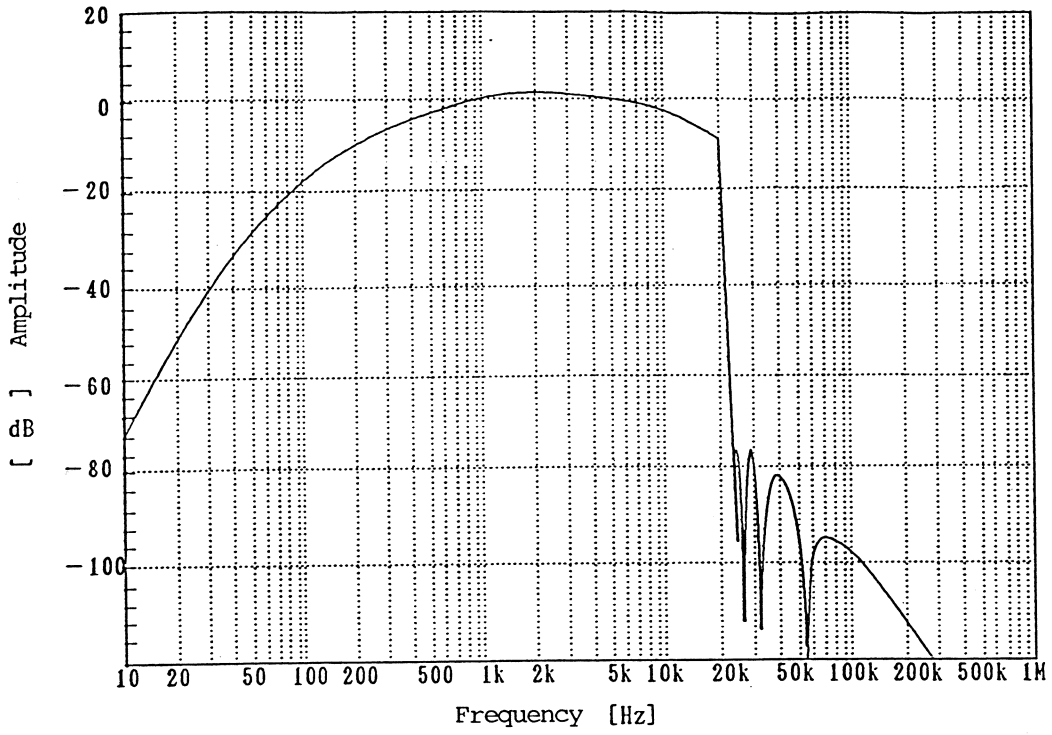

Fig. 5-3 Amplitude response of the serial connection  
of Low pass and IEC-651-A filters





If there are any misplaced or missing pages, we will replace the manual. Contact the sales representative.

#### NOTES

- Reproduction of the contents of this manual is forbidden by applicable laws.
- The contents of this manual may be revised without notice.
- Information provided in this manual is intended to be accurate and reliable. However, we assume no responsibility for any damage regarding the contents of this manual.
- We assume no responsibility for influences resulting from the operations in this manual.

Copyright *NF CORPORATION*

*NF CORPORATION*

6-3-20, Tsunashima Higashi, Kohoku-ku,

Yokohama 223-8508

JAPAN

Phone (045) 545-8111 Fax (045) 545-8191 Telex 3823-297





