

LOW NOISE DC POWER SUPPLY

LP series

Extremely Low Noise

CE

Low Noise

Low Drift



Output Noise 10 μVrms or lower typ.
(Bandwidth : 10 Hz to 20 MHz)

Output Voltage Stability ± 10 ppm/ $^{\circ}\text{C}$ typ.

Ultra low noise DC power supply for demanding low noise precision measurement applications

Utilizing our proprietary circuit design technology, the LP series of ultra-low noise DC power supplies provides output voltage with extremely low levels of noise. The main unit is shielded and shielded connectors and cables are used to prevent the emission of internal noise as well as prevent external noise from affecting the signal. The combination of all these technologies results in a DC power supply that produces output with a superior level of low noise.

The LP series is suitable for high-precision measurement applications such as sensor preamp power supplies and DC bias power supplies used in advanced device research, analysis devices, and medical equipment.

LP5394

The output noise voltage is at most 10 μ Vrms. This represents the highest standard of low-noise DC power supplies, yet we are able to offer the LP series at reasonable prices.

Additionally, we have incorporated low-noise and highly stable reference voltage sources to achieve a level of temperature stability higher than conventional DC power supplies by a factor of 5 to 10.

By eliminating wasted time in efforts to reduce noise, the LP series is perfect for research and development environments that use batteries or internally developed power supplies to prevent power supply noise from affecting device characteristics.

Our power supplies have the capability to provide stable and reliable power for extended periods of time.

- Low Noise : Output Noise : 10 μ Vrms or lower (typ.)(10 Hz to 20 MHz bandwidth)
- Low Drift : Output Voltage Stability : \pm 10 ppm/ $^{\circ}$ C (typ.)
- Output Voltage : 0 to \pm 15 V ● Output Current : 0.1 A max.
- Voltage Setting Range : 3 V, 5 V, 10 V or 15 V F.S.
- Precisely adjusts the output voltage using the 10-turn potentiometer
- 1/4-rack sized for easy integration into multi-channel rack systems



LP5393

With an output noise voltage of at most 10 μ Vrms, the LP5393 DC power supply maximizes the performance capabilities of our SA series of low-noise amplifiers (voltage amplifiers and current amplifiers). Vastly reduced noise levels compared to conventional products.

- Output Noise : 10 μ Vrms or lower (typ.)
- Output Voltage Stability : \pm 20 ppm/ $^{\circ}$ C (typ.)
- Output Voltage : \pm 12 V to \pm 15 V
- Output Current : 0.1 A max.
- 1/4-rack size

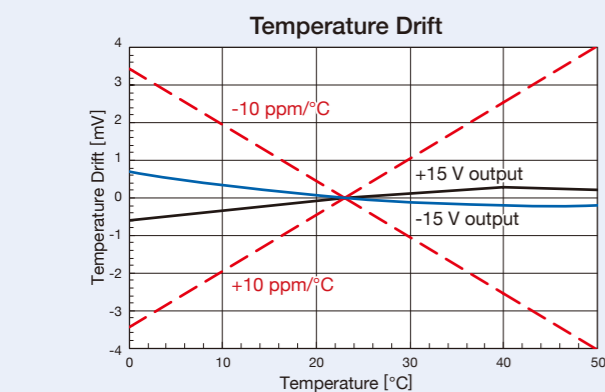
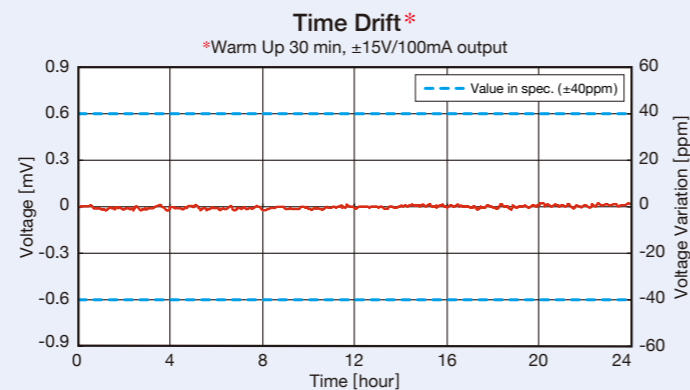
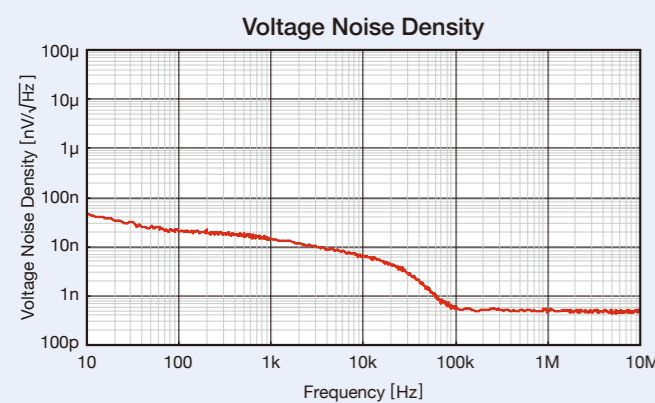
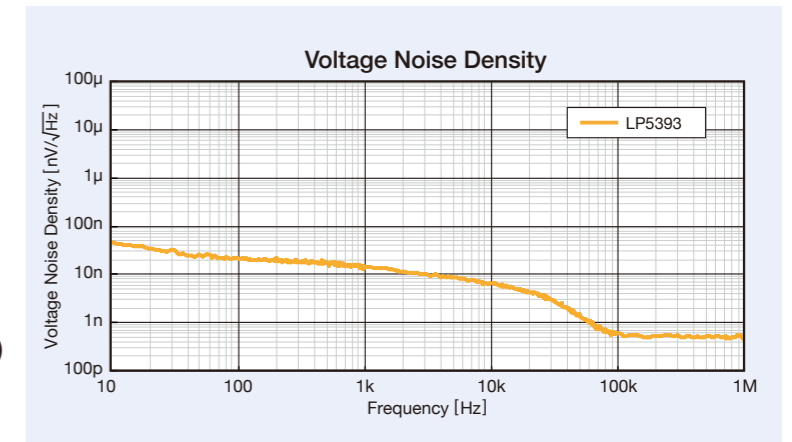

Output Voltage Waveform (15 V output)

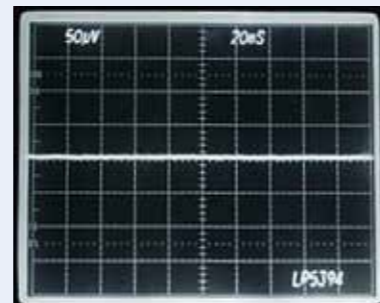

Oscilloscope BW =1 MHz
(X-axis : 20 ms/div., Y-axis : 50 μ V/div.)

Front View of LP5394

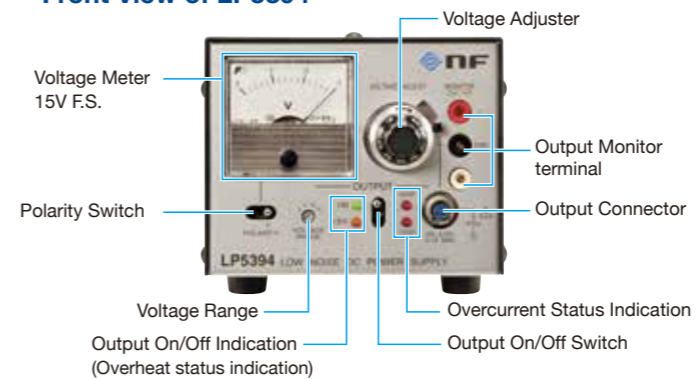

Rear View

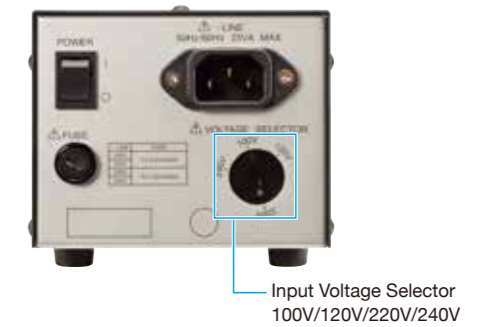

OPTIONS

Output Conversion Adapter



PA-001-2590
BNC Adapter
Converts output to BNC output for LP series

*Output Cable A is required



PA-001-2591
Binding Post Adapter
Converts output to binding post output for LP series

*Output Cable A is required

Output Cable



PA-001-2372
Output Cable A (Length : 2 m)
for PA-001-2590, PA-001-2591, SA600 series, SA410F3, SA-240F5, and SA-440F5



PA-001-2373
Output Cable B (Length : 2 m)
for SA-200 series (except for SA-230F5)v and SA-400 series



PA-001-2374
Output Cable C (Length : 2 m)
for SA-230F5

Rack Mount Kit

PA-001-2642 **Rack Mount Kit** (EIA, for 4 units)
PA-001-2643 **Rack Mount Kit** (JIS, for 4 units)

LP5394 SPECIFICATIONS

Output voltage	0 to ± 15 V
Voltage setting range	Set with the VOLTAGE RANGE switch on the front panel Setting range 3 V 0 to ± 3 V Setting range 5 V 0 to ± 5 V Setting range 10 V 0 to ± 10 V Setting range 15 V 0 to ± 15 V
Voltage setting method	Set with the adjuster on the front panel (VOLTAGE ADJUST dial that turns in 10 turns) The voltage can be adjusted from 0 V to the full-scale The full-scale voltage is output when in dial setting 10. The minimum scale on the dial is 0.2% of the full-scale voltage
Voltage setting accuracy	$\pm 1\%$ of full-scale voltage in dial settings 1 to 10 0 ± 20 mV in dial setting 0
Maximum current	± 0.1 A
Output ON/OFF	Set with the front panel switch
Voltage meter	Class 2.5, full-scale 15 V with POLARITY switch
Output monitor	Set with the MONITOR terminal on the front panel ($Z_{out} = 1$ k Ω)
Input regulation	Within ± 3.5 mV (for power supply $\pm 10\%$)
Load regulation	Within ± 10 mV (load 0% reference for load 0 to 100%)
Ripple noise	10 μ Vrms or lower (typ.) (load 0 to 100%, bandwidth 10 Hz to 20 MHz)
Output voltage temperature coefficient*1	± 10 ppm/ $^{\circ}$ C (typ.)
Time drift*1	± 40 ppm (typ.) (8 hours after warm-up)
Output connector	HR10-7R-4S (73) (on the front panel) Hirose Electric
Input voltage	AC 100, 120, 220 and 240 V (selector switch) $\pm 10\%$ However, AC 250 V or lower
Frequency	50 Hz/60 Hz ± 2 Hz
Power consumption	25 VA or lower
Overvoltage category	II
Insulation resistance	Between all power inputs and chassis 50 M Ω or more (with DC 500 V) Between all power inputs and outputs 50 M Ω or more (with DC 500 V) Between output GND and chassis 10 M Ω
Withstanding voltage	Between all power inputs and chassis AC 1500 V for 1 minute Between all power inputs and outputs AC 1500 V for 1 minute Between output GND and chassis ± 42 Vpk (DC + ACpeak)
Protection functions	Overcurrent protection Drooping characteristic (approx. 0.15 A) self-recovery type Overcurrent status indication By the front panel +OCP LED and -OCP LED Overheat protection Output is turned off at an internal temperature of approx. 75 $^{\circ}$ C Overheat status indication Front panel OUTPUT OFF LED flashes (self-recovery)
Operating temperature range	0 to +50 $^{\circ}$ C (day's average temperature 40 $^{\circ}$ C or lower)
Operating humidity range	25 to 80% RH absolute humidity 1 to 25 g/m 3 , non-condensation
Storage temperature range	-10 to +50 $^{\circ}$ C (day's average temperature 40 $^{\circ}$ C or lower)
Storage humidity range	25 to 80% RH absolute humidity 1 to 29 g/m 3 , non-condensation
Cooling method	Natural convection cooling
Pollution degree	2 (indoor use)
Warm-up time	30 minutes
Dimensions (mm)	107(W) \times 86(H) \times 330(D) (without protrusions)
Weight	Approx. 1.75 kg (without accessories)
RoHS	Directive 2011/65/EU
EMC	EN 61326-1: 2013 (Group 1, Class A) EN 61000-3-2: 2006 + A1: 2009 + A2: 2009 EN 61000-3-3: 2013
Safety	EN 61010-1: 2010
Accessories	Power cord set (3 pole, 2 m), Fuse (100 V/120 V : 0.315 A or 220 V/240 V : 0.125 A) (Time-lag, $\phi 5.2$ x 20 mm), Instruction manual

*1 For the full-scale voltage of the range.

LP5393 SPECIFICATIONS

Output voltage	± 12 V to ± 15 V
Voltage setting	± 15 V $\pm 1\%$ when adjuster turned all the way to right ± 12 V $\pm 1\%$ when adjuster turned all the way to left
Voltage setting method	Set with the front panel adjuster
Maximum current	± 0.1 A
Output ON/OFF	Set with the front panel switch
Output monitor	Set with the MONITOR terminal on the front panel ($Z_{out} = 1$ k Ω)
Input regulation	Within ± 3.5 mV (for power supply $\pm 10\%$)
Load regulation	Within ± 15 mV (load 0% reference for load 0 to 100%)
Ripple noise	10 μ Vrms or lower (typ.) (load 0 to 100%, bandwidth 10 Hz to 20 MHz)
Output voltage temperature coefficient	± 20 ppm/ $^{\circ}$ C (typ.)
Time drift	± 50 ppm (typ.) (8 hours after warm-up)
Output connector	HR10-7R-4S (73) (on the front panel) Hirose Electric
Input voltage	AC 100, 120, 220 and 240 V (selector switch) $\pm 10\%$ However, AC 250 V or lower
Frequency	50 Hz/60 Hz ± 2 Hz
Power consumption	25 VA or lower
Overvoltage category	II
Insulation resistance	Between all power inputs and chassis 50 M Ω or more (with DC 500 V) Between all power inputs and outputs 50 M Ω or more (with DC 500 V) Between output GND and chassis 10 M Ω
Withstanding voltage	Between all power inputs and chassis AC 1500 V for 1 minute Between all power inputs and outputs AC 1500 V for 1 minute Between output GND and chassis ± 42 Vpk (DC + ACpeak)
Protection functions	Overcurrent protection Drooping characteristic (approx. 0.15 A) self-recovery type Overcurrent status indication By the front panel +OCP LED and -OCP LED Overheat protection Output is turned off at an internal temperature of approx. 75 $^{\circ}$ C Overheat status indication Front panel OUTPUT OFF LED flashes (self-recovery)
Operating temperature range	0 to +50 $^{\circ}$ C
Operating humidity range	5 to 85% RH absolute humidity 1 to 25 g/m 3 , non-condensation
Storage temperature range	-10 to +60 $^{\circ}$ C
Storage humidity range	5 to 95% RH absolute humidity 1 to 29 g/m 3 , non-condensation
Cooling method	Natural convection cooling
Pollution degree	2 (indoor use)
Warm-up time	30 minutes
Dimensions (mm)	107(W) \times 86(H) \times 330(D) (without protrusions)
Weight	Approx. 1.7 kg (without accessories)
RoHS	Directive 2011/65/EU
EMC	EN 61326-1: 2013 (Group 1, Class A) EN 61000-3-2: 2006 + A1: 2009 + A2: 2009 EN 61000-3-3: 2013
Safety	EN 61010-1: 2010
Accessories	Power cord set (3 pole, 2 m), Fuse (100 V/120 V : 0.315 A or 220 V/240 V : 0.125 A) (Time-lag, $\phi 5.2$ x 20 mm), Instruction manual

Note: The contents of this catalog are current as of November 6th, 2024

*Products appearance and specifications are subject to change without notice.

•Before purchase contact us to confirm the latest specifications, price and delivery date.

NF Corporation

Head Office

6-3-20 Tsunashima Higashi, Kohoku-ku, Yokohama 223-8508, Japan

Phone : +81-45-545-8128 Fax : +81-45-545-8187

<http://www.nfcorp.co.jp/english/>