

GAIN-PHASE ANALYZER

FRA51602

Loop-Gain Measurement for Inverters and Switching Power Supplies

Maximum Voltage

600V

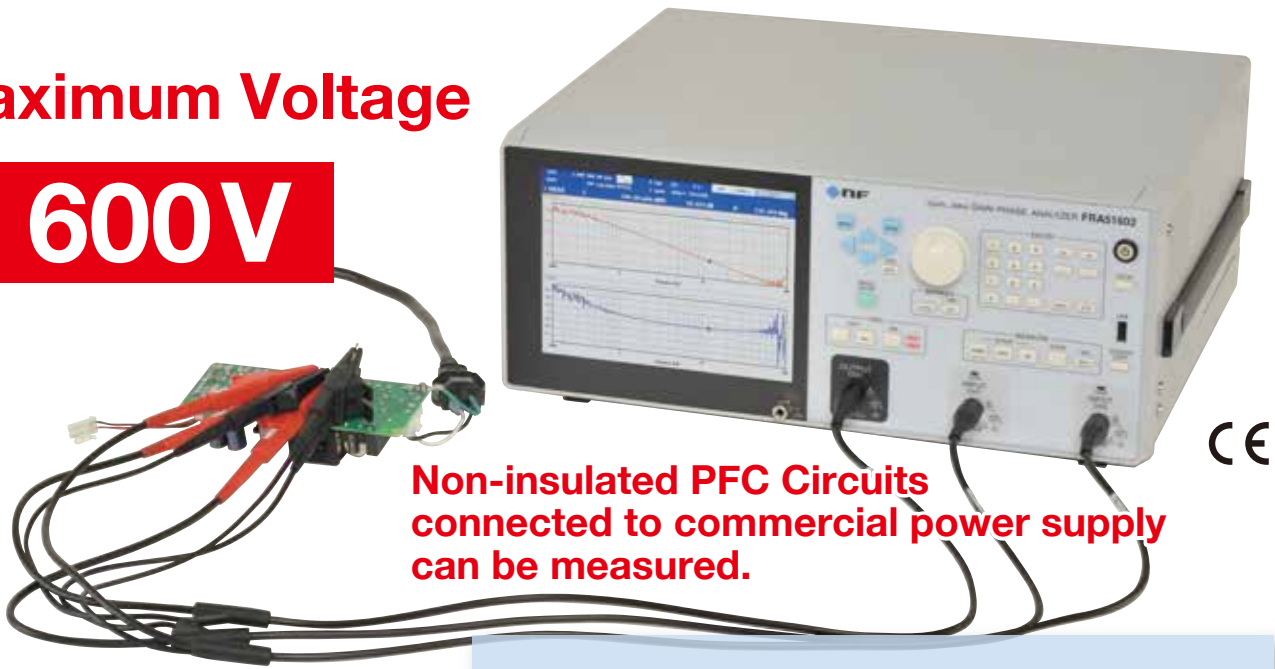

Non-insulated PFC Circuits
connected to commercial power supply
can be measured.



Measurement of Transmission Efficiency
on Wireless Charging

Measurement of Mechanical Servo
Characteristic

Measurement of Frequency Response
of Filters and Amplifiers

Acoustic Analysis

Vibration Analysis

- Measurement Frequency 10 μ Hz to 2 MHz
- Measurement Speed 0.5 ms/point
- Basic Accuracy Gain : ± 0.01 dB
 Phase : $\pm 0.06^\circ$
- Maximum Measurement Voltage 600 Vrms
- Maximum Input Voltage 600 V CAT II / 300 V CAT III
- Isolation 600 V CAT II / 300 V CAT III
- Dynamic Range 140 dB

Measuring
faster than ever

- Auto Ranging ● Automatic High Density Sweep
- Delay Function ● Group Delay
- Amplitude Compression Function
- Sequence Measurement Function
- Marker Search Function
- Measurement Function for Changing the Frequency at 0° -phase

For Evaluating Circuit and Servo System



Maximum Voltage 600V
High Accuracy (Gain, Phase)
Wide Dynamic Range
Input/output Isolation...

Specifications and Functionality to Ensure Reliable and Highly Accurate Measurements

Measurement frequency 10 μHz to 2 MHz

Supports low frequencies of 10 μHz all the way to 15 MHz. Resolution has also been increased to 10 μHz.

Basic accuracy Gain ±0.01 dB, Phase ±0.06°

Highly accurate measurements are achieved with digital Fourier conversion and self-calibration functionality. *Accuracy varies depending on testing conditions.

Isolation 600 V CAT II / 300 V CAT III

The oscillator output (OSC) and 2 analysis inputs (CH1 and CH2) are isolated from the chassis. Terminals are also isolated from each other. Available isolation ratings include 600 V CAT II and 300 V CAT III. In addition to the loop and gain testing of power circuits such as high-voltage inverters and PFC circuits, this further expands the range of applications supported by FRAs.

Automatic high density sweep :

Automatic adjustment of frequency density specifically during intervals of sudden changes in measurement.

Amplitude compression :

To prevent saturation and damage of test devices, oscillator levels are controlled to match the level of the test device.

Delay function :

Delays the start of testing to reduce error caused by transient responses during frequency changes.

Measurement speed 0.5 ms/point

Maximum sweep speed of 0.5 ms/point is definitely fast. This device can help reduce the production line tact times. Significantly faster than conventional models.

Dynamic range 140 dB

A larger dynamic range has been achieved with a high-resolution A/D converter and auto ranging functionality that optimizes testing ranges per frequency measurement point.

Auto range

This feature automatically tracks the input signal level so that the range is constantly optimized during testing. Once noise that exceeds the range is detected, the system automatically sets a larger range. Measurement data will not become saturated within specific ranges. Due to resolve the problem of non-continuous measurement values as a result of range changes, a fixed range can also be selected.

Integration function :

To remove the effects of noise during measuring.

Auto integration function :

Integrals are repeated until variation in measurements due to noise falls below a preconfigured value.

Equalize function :

Corrects measurement-related errors by measuring the frequency response of externally connected sensor, cables, and other beforehand.

Increasing testing efficiency !

Sequential testing

Sweep measurements can be performed in accordance with a numerical order that is read from configuration memory. The frequency range can be divided up to 20 parts per sweep so that these different frequency ranges can be measured using different amplitude and integral settings.

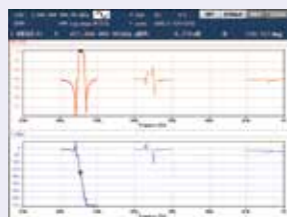

Group delay measurement

This system can display group delay (GD, phase differentials between input and output by frequency) used to evaluate reproducibility of waveforms of filters and other electronic components.

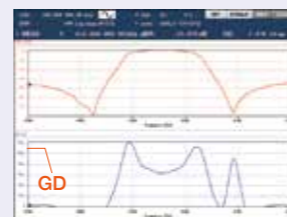

Marker Search Function Automatic search available

In addition to moving to a marker and reading the value, the system can automatically search for points matching configured criteria. For example, it is possible to detect "phase margin" and "gain margin" by searching 0 dB and 0° at the end of sweep measurement.

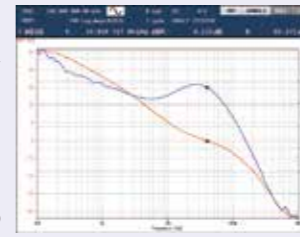

Phase Control during Frequency Changes

Frequencies are changed at the timing at which the phase of the oscillator signal is at 0°. The frequency response of high-pass filters (HPF) can be measured without any DC transient responses.

Differentiation and Integration Function

This feature calculates differentials, second-order differentials, integrals, and double integrals for the time domain of measurement data. For example, this is useful for calculating displacement, speed, and acceleration from acceleration sensor or laser doppler vibrometers.

A Variety of Graph Displays

- Split Display**
Both SINGLE mode that displays one graph per page and a SPLIT mode that displays an upper graph and lower graph are available.
- Data Trace**
A reference data trace (REF) and a measurement data trace (MEAS) can be drawn as overlays.
- Phase Unwrap Display**
Displays the phase continuously without using 0°, 180°, and 360° as cross-over points. Phases exceeding ±360° can also be displayed.



Various Evaluations Under Actual Driving Conditions for Devices!

Example Loop Gain Measurement of Non-insulated PFC Circuit

The output voltage of non-insulated PFC Circuit is a potential of the input power supply. It is necessary to use the AC power supply on the input side when the measurement instrument connected on the output side is not compliant with measurement categories.

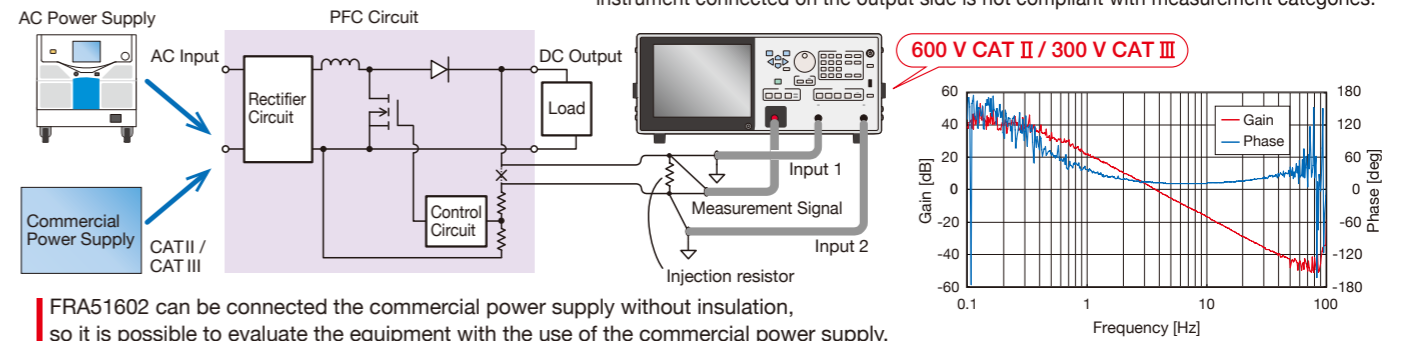

FRA51602 can be connected the commercial power supply without insulation, so it is possible to evaluate the equipment with the use of the commercial power supply.

SPECIFICATIONS

Oscillator Section

Frequency	10 μHz to 2 MHz, Setting resolution : 10 μHz Accuracy : ±10 ppm (operating on the internal reference clock)
AC Signal Amplitude	0 to 10 Vpk Setting resolution of 3 digits or 0.01 mVpk, whichever is greater
DC Bias	-10 V to +10 V, Setting resolution : 10 mV
Output Impedance	50 Ω ±2% (1 kHz)
Maximum Output (AC + DC)	Voltage : ±10 V Current : ±100 mA
Sweep	Sweep density : 3 to 20,000 steps/sweep Sweep type : Linear or log, selectable Sweep time : Fastest 0.5 ms (per frequency point)
Output Control	QUICK : Immediately changes to the set voltage or to 0 V SLOW : Changes to the set voltage or to 0 V gradually over a period of about 10 seconds Function for turning off and changing the frequency at 0° phase Possible to turn the AC and DC on / off at the same time or to turn off the AC independently Possible to turn on automatically at the start of measurement and to turn off automatically at the end of measurement
Connector	Insulated BNC (front panel, OSC)
Isolation	600 V CAT II / 300 V CAT III (BNC grounded to the enclosure)
DC BIAS OUT (rear panel)	When the DC BIAS OUT is set as the output connector for the DC bias. Connector : BNC Setting Range : -10 V to 10 V Output resistance : 600 Ω ±2%

Analysis Input Section

Input Channels	2 (CH1, CH2)
Input Connector	Insulated BNC
Input Impedance	1 MΩ ±2%, 20 pF ±5 pF
Measurement Range	10 ranges (30 m/100 m/300 m/1/3/10/30/100/300/600 Vrms) or Auto range (setting CH1 and CH2 independently)
Maximum Input Voltage	600 V CAT II / 300 V CAT III
Maximum Measurement Voltage	600 Vrms (when using bundled signal cables)
Dynamic Range	140 dB (10 Hz to 1 MHz), 80 dB (1 MHz to 2 MHz)
IMRR	120 dB or more (DC to 60 Hz)
Isolation	600 V CAT II / 300 V CAT III (BNC grounded to the enclosure)

Measurement Processing Section

Measurement Operations	UP SWEEP (In order of increasing frequency), DOWN SWEEP (In order of decreasing frequency), SPOT (At the current frequency, no sweep), REPEAT (Repeatedly measurement), SINGLE (A single measurement)
Integration Function	Integration on measurement data to remove the effects of noise
Delay Function	Delays the beginning of a measurement after the frequency is changed.
Start Delay Function	Delays the beginning of a measurement only from the start of a sweep or spot measurement
Automatic Integration	Repeats the integration process until the variation in the measurement values falls below a set value
Amplitude Compression	Controls the level of oscillation so that the amplitude level of DUT may stay at a certain value.
Automatic High Density Sweep	When measured data changes greatly, sweep density is made higher around the frequency area automatically.
Sequence Measurement	Measurements according to the content of a condition memory

■ Analysis Processing Section

Measurement Accuracy	
Fixed Range	
Measurement accuracy = Relative accuracy + Calibration accuracy	
Relative accuracy = $\pm(\text{Basic accuracy} + \text{Dynamic accuracy} + \text{Inter-range accuracy} \times N)$	
Calibration accuracy : Accuracy of external equipment that is connected to the instrument, such as a shunt resistor or probe, or the accuracy of the calibration standard equipment	
Basic accuracy (excerpt) : Gain (ratio) / Phase	
≤200 kHz and 30 mV to 30 V ranges : ±0.01 dB / ±0.06°	
≤100 kHz and 600 V ranges : ±0.2 dB / ±1.2°	
≤2 MHz and 30 mV to 30 V ranges : ±0.1 dB / ±0.6°	
[Conditions]	
- At least 30 cycles of integration	
- Fixed and the same measurement range for both channels.	
- The gain and phase error for when the signal input is at the full scale of the measurement range for both channels	
Dynamic accuracy (excerpt) : Gain (ratio) / Phase	
≤100 kHz and 300 mV to 600 V ranges : ±0.1 dB / ±0.6°	
≤2 MHz and 100 mV to 10 V ranges : ±0.2 dB / ±1.2°	
[Conditions]	
- At least 30 cycles of integration	
- Fixed and the same measurement range for both channels.	
- Gain and phase variation for when the signal level changes from full-scale of measurement range to 1/10. The input signal level is 1:1 or 1:0.1 between channels.	
Inter-range accuracy (excerpt) : Gain (ratio) / Phase	
≤100 kHz and ≤300 V range : ±0.05 dB / ±0.3°	
≤2 MHz and ≤30 V range : ±0.05 dB / ±0.3°	
[Conditions]	
- At least 30 cycles of integration	
- Fixed measurement range for both channels	
- The gain and phase error for when the measurement range difference between channels is 1, the input signal levels of both channels are equal, and equal to the range full scale level of the smaller range.	
Auto Range	
Measurement accuracy = Relative accuracy + Calibration accuracy	
Relative accuracy = $\pm(\text{Basic accuracy} + \text{Dynamic accuracy})$	
Calibration accuracy : The accuracy of external equipment that is connected to the instrument, such as a shunt resistor or probe, or the accuracy of the calibration standard equipment.	
Basic accuracy (excerpt) : Gain (ratio) / Phase	
≤200 kHz and signal level of 7 Vrms : ±0.02 dB / ±0.12°	
≤2 MHz and signal level of 7 Vrms : ±0.1 dB / ±0.6°	
[Conditions]	
- At least 30 cycles of integration	
- Auto-range for both channels	
- The gain and phase error for when the input signal level is the same for both channels.	
Dynamic accuracy (excerpt) : Gain (ratio) / Phase	
≤100 kHz and signal level of 30 Vrms to 600 Vrms : ±0.1 dB / ±0.6°	
≤2 MHz and signal level of 100 mVrms to 30 Vrms : ±0.2 dB / ±3.0°	
[Conditions]	
- At least 30 cycles of integration	
- Auto-range for both channels	
- The gain and phase variation for when input signal level with the greater signal level channel changes from 7 Vrms to the value of the table, when the input signal level between channel is 1:1 or 1:0.1.	
Error Correction Function	Corrects for measurement errors that arise within the instrument itself (Calibration)
Analysis Modes	Ratio : CH1/CH2, CH2/CH1 Amplitude : CH1, CH2
Graph Types	Bode plot, Nyquist plot, Nichols plot
Measurement Items	dBR (gain dB), θ (phase), GD (group delay) R (absolute gain/amplitude) a (real part of gain/real part of amplitude) b (imaginary part of gain/imaginary part of amplitude)
Error Correction Function (Equalizing)	This function obtains the characteristics for DUT alone by measuring the frequency characteristics of the measurement system (sensors, cables, etc.) in advance and then eliminate that error components.

Note : The contents of this catalog are current as of November 6th, 2024
 *Products appearance and specifications are subject to change without notice.
 ●Before purchase contact us to confirm the latest specifications, price and delivery date.

■ Display Section

Display Unit	8.4-inch color TFT-LCD (SVGA) with touch screen
Graph Display Styles	SINGLE or SPLIT (Two graphs are displayed on the screen, one above the other.)
Data Traces	Reference data trace (REF) or measurement data trace (MEAS)
Auto Scaling	On or Off (automatically optimizes the graph display scale)
Marker Search Function	Search items : Max, Min, Peak, Bottom, Next Peak, Next Bottom, Value, ΔValue, X Value Possible to automatically perform a search at the end of a sweep measurement.

■ Others

Memory	Measurement data (MEAS) : Up to 20 sets Reference data (REF) : Displayed on a graph together with the measurement data (on/off) Error correction data, Measurement conditions : Up to 20 sets
External Memory	USB memory (Front panel, USB-A connector) File system : FAT, Screen capture : BMP
Interface	GPIB (IEEE488.1, IEEE488.2), USB (USBTMC), LAN (10/100 Base-T), RS-232 (4800 to 230400 bps)
External Monitor	VGA (Rear panel)
Reference Clock	Input : Within 10 MHz ±100 ppm, 0.5 Vp-p to 5 Vp-p Output : Within 10 MHz ±10 ppm, 1 Vp-p / 50 Ω
DC Power Output	For Signal Injector Probe 5055 (option), ±24 V
Power Requirements	AC100 V to 230 V±10% (250V or less), 50 Hz/60 Hz ±2 Hz
Power Consumption	100 VA or less
Ambient Temperature and Humidity	+5°C to +40°C, 5 to 85%RH (absolute humidity 1 to 25 g/m³, no condensation)
Dimensions (mm)	430 (W) × 177 (H) × 350 (D) (excluding protruding parts)
Weight	Approx. 8.5 kg
Safety Standards and EMC	EN 61010-1, EN 61010-2-030 EN 61326-1 (Group 1, Class A), EN 61326-2-1
RoHS	Directive 2011/65/EU

Accessories

- Instruction Manual (operation and remote control)
- Power Cord Set (2 m, with three-pin plug)
- Signal Cables (BNC-BNC, 50 Ω, 1 m, 600 V CAT II) ×3
- Calibration Cables (BNC-BNC, 50 Ω, 20 cm) ×2
- BNC Adapter (600 V CAT II)

Options (sold separately)

5055	Signal Injector Probe	
PA-001-0369	Loop Gain Measurement Adapter	
PA-001-3746	High Withstand Voltage Clip Cable Set*	
PA-001-0420	High Withstand Voltage Alligator Clip Cable Set (small)*	
PA-001-0421	High Withstand Voltage Alligator Clip Cable Set (large)*	
PA-001-3058	High Withstand Voltage BNC Extension cable set (15 cm)*	
PC-007-0364	High Withstand Voltage BNC Extension cable (1m)	
PA-001-3036	Rack Mount Kit (EIA)	
PA-001-3037	Rack Mount Kit (JIS)	* 3 per set

Rear Panel

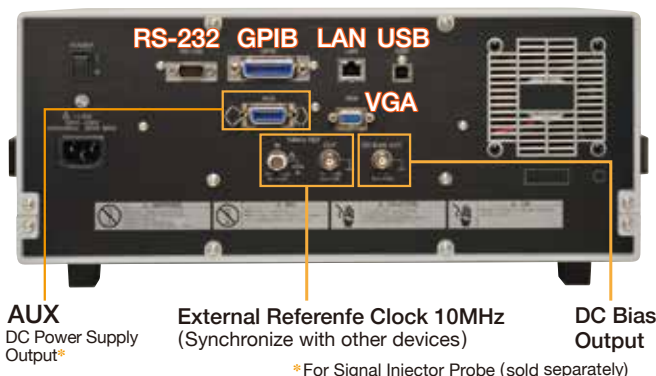

NF Corporation

Head Office
 6-3-20 Tsunashima Higashi, Kohoku-ku, Yokohama 223-8508, Japan
 Phone : +81-45-545-8128 Fax : +81-45-545-8187
<http://www.nfcorp.co.jp/english/>