



**LOW NOISE DC VOLTAGE SOURCE**

**LP6016-01**

---

**INSTRUCTION MANUAL**



DA00071122-003

**LOW NOISE DC VOLTAGE SOURCE**

**LP6016-01**

**INSTRUCTION MANUAL**

## ----- Preface -----

Thank you for purchasing the "LP6016-01 LOW NOISE DC VOLTAGE SOURCE".  
For safe and correct use of this product, please read the following "Safety Precautions" section before attempting to use this product.

### ■ Marks and symbols

For safe operation and prevent damage to this product, please note the following marks and symbols that are used in this manual.

---

#### **WARNING**

This mark indicates information for preventing the possibility of death or serious personal injury from electrical shock or other hazards or damage to this product when using or handling it.

---

---

#### **CAUTION**

This mark indicates information for preventing the possibility of injury to the user or damage to this product when handling it.

---

### ■ The chapter structure of this manual is described below.

If you are using this product for the first time, begin reading from Chapter 1.

#### 1. **Outline**

This chapter gives an overview and describes the features and simple operation principles of this product.

#### 2. **Preparation before use**

This chapter describes important preparation before installation and operation.

#### 3. **Explanations of the panel**

This chapter explains the names and functions of each part on the panel. Please read it while operating this product.

#### 4. **Operation procedure**

This chapter explains the functions and operating procedure of each part on the panel. Please read it while operating this product.

#### 5. **Remote control**

This chapter explains remote control with each interface.

#### 6. **Troubleshooting**

This chapter describes how to handle error messages and cases in which you think the product is malfunctioning.

#### 7. **Maintenance**

This chapter explains maintenance, repacking, transportation, and performance-testing methods.

#### 8. **Specifications**

This chapter describes the product specifications (functions and performance).

#### 9. **Typical data**

This chapter describes the typical data of the major specification items.

## ----- Safety Precautions -----

For safe use of this product, be sure to comply with the following warnings and cautions.

NF Corporation shall not be held liable for damages that arise from failure to obey these warnings and cautions.

This product is a Class I equipment (with protective conductor terminal) that conforms to the JIS and IEC standards.

### ■ **Ensure that you comply with the instructions in this instruction manual**

This instruction manual contains information for the safe operation and use of this product.

Please read this manual before using this product.

All the warning items contained in this instruction manual are intended for preventing risks that may lead to serious accidents. Ensure that you comply with them.

### ■ **Ensure that this product is grounded**

There is risk of electrical shock if this product is not grounded.

To prevent electrical shock accidents, connect this product to an earth ground so that ground resistance is 100  $\Omega$  or less.

This product is automatically grounded by connecting a 3-pole power plug to a power outlet with a protective ground contact.

This product does not come with a 3-pole to 2-pole conversion adapter.

If you must use a 3-pole to 2-pole conversion adapter, be sure to connect the ground line of the adapter to a suitable ground near the power outlet.

### ■ **Check the power supply voltage**

This product operates on the power supply voltage described in "2.3 Grounding and Power Connections".

This product has a power-supply-voltage-select function. Before connecting to the outlet, check that the set power supply voltage matches the voltage of the outlet.

### ■ **Observe the rating of the fuse**

Failure to do so may cause fire or other accidents. Use a fuse with the rating specified in "2.3 Grounding and Power Connections".

When replacing the fuse, be sure to disconnect the power plug from the outlet.

### ■ **If you notice something wrong**

If smoke, an unusual odor, or sound comes from this product, immediately remove the power cord from the outlet and cease use.

If any such abnormality occurs, take measures to prevent the use of this product and promptly contact NF Corporation or an authorized agent. Never use it until the repair is completed.

### ■ Do not use in an explosive atmosphere

This may cause an explosion.

### ■ Do not open the case of this product

To prevent exposure to high voltages, never open the case of this product.

Even when inspection inside of this product is needed, only service engineers certified by NF Corporation should touch the inside.

### ■ Do not modify this product

Never modify this product in any way. Modification might create new risks. NF Corporation may refuse to service the product if it has an unauthorized modification.

### ■ Do not expose this product to water

When this product is used under wet conditions, it may cause an electric shock or fire.

If this product becomes wet, immediately disconnect the power plug from the outlet and contact NF Corporation or an authorized agent.

### ■ If lightning occurs nearby, turn off the power switch and disconnect the power plug

Lightning strikes may cause electric shock, fire, or product malfunction.

### ■ Safety-related symbols

The marks and codes defined below are used in this manual or on this product to indicate safety information or instructions.



#### **Instruction manual reference symbol**

This notifies the user of a potential hazard and indicates that the user must refer to the instruction manual.



#### **Electric shock danger symbol**

This indicates a location that presents a risk of electric shock under specific conditions.



#### **Warning symbol**







This contains information to avoid risks when handling this product that could result in the death or serious injury of the user.



#### **Caution symbol**

This contains information to avoid risks when handling this product that could result in minor or moderate injury of the user or damage to property.

### ■ Other symbols

	Indicates the "ON" position of the power switch.
	Indicates the "OFF" position of the power switch.
	Indicates that it is connected to the product enclosure (ground).
	Indicates that it is connected to the output common (COM).
	Indicates that it is isolated from the product enclosure (ground).
	However, safe operation of this product requires that the potential difference from the ground is restricted to 42 Vpk or less.

### ■ Electromagnetic compatibility

This product is a CISPR 11 Group 1 Class A compliant instrument. It should not be used outside industrial environments. Use of this product in ordinary office or residential areas may result in electromagnetic interference with other devices.

### ■ Regarding disposal

Pay attention to the following contents when disposing of this product for environmental conservation.

- a) Dispose this product through a dealer handling industrial waste.
- b) This product does not contain batteries.
- c) This product does not contain mercury.

---

## Contents

---

	Page
1. Outline .....	1-1
1.1 Overview .....	1-2
1.2 Features .....	1-2
1.3 Operation principles .....	1-2
1.4 Block diagram .....	1-3
2. Preparation before use .....	2-1
2.1 Checking before use .....	2-2
2.2 Installation .....	2-3
2.2.1 General cautions .....	2-3
2.2.2 Installation environment .....	2-3
2.2.3 Rack mounting .....	2-4
2.3 Grounding and Power Connections .....	2-13
2.4 Quick operation check .....	2-16
2.4.1 Check operation at power on .....	2-16
2.4.2 Check the output voltage .....	2-17
3. Explanations of the panel .....	3-1
3.1 Name of each part of the panels .....	3-2
3.1.1 Front panel .....	3-2
3.1.2 Rear panel .....	3-2
3.2 Function of each part of the panels .....	3-3
3.2.1 Front panel .....	3-3
3.2.2 Rear panel .....	3-4
4. Operation procedure .....	4-1
4.1 Display and operation for powering up .....	4-2
4.1.1 What to check before turning the power on .....	4-2
4.1.2 Turning power on and off .....	4-2
4.1.3 Setting at power on .....	4-2
4.1.4 Startup behavior and display .....	4-2
4.1.5 Warm-up time .....	4-2
4.2 The list of panel operations and functions .....	4-3
4.2.1 Basic panel operation and display examples .....	4-4
4.2.2 Setting the output voltage (VOLTAGE) .....	4-7
4.2.3 Setting the limit voltage (LIMIT) .....	4-9
4.2.4 Setting of the remote control (INTERFACE) .....	4-11
4.2.5 Others (UTILITY) .....	4-19
4.3 Operations no included in the menu tree .....	4-26
4.3.1 Switching the output on and off .....	4-26
4.3.2 Switching from remote control state to local operation state .....	4-26
4.3.3 Initialization of the LCD setting .....	4-26
4.4 Connection notes .....	4-27
4.4.1 Output connection .....	4-27



---

## Contents

---

4.4.2	Current-monitor connection.....	4-27
5.	Remote control .....	5-1
5.1	Preparations before remote control.....	5-2
5.1.1	Select the remote control interface .....	5-2
5.1.2	USB interface.....	5-2
5.1.3	RS-232 interface.....	5-4
5.1.4	LAN interface .....	5-6
5.1.5	Precautions for remote control .....	5-8
5.2	Changing of remote control and local operation states .....	5-8
5.3	Commands .....	5-9
5.3.1	Parameter Formats .....	5-9
5.3.2	Symbols .....	5-9
5.3.3	Input format.....	5-9
5.4	Command explanations .....	5-10
5.4.1	Switch output on/off .....	5-10
5.4.2	Output voltage (Voltage) .....	5-11
5.4.3	Limit voltage (LIMIT) .....	5-11
5.4.4	Output mode (Vout MODE) .....	5-12
5.4.5	Voltage setting mode (Vset MODE) .....	5-12
5.4.6	The output state at startup (POW ON Vout).....	5-13
5.4.7	Brightness of the LCD (LCD LIGHT) .....	5-14
5.4.8	Contrast of the LCD (LCD CONTRAST).....	5-14
5.4.9	Query the abnormal state.....	5-15
5.4.10	Query the error queue.....	5-15
5.4.11	Clear the error queue.....	5-15
5.4.12	Query the product information.....	5-16
5.4.13	Reset (Initialize).....	5-16
5.4.14	Switching from remote control state to local operation state .....	5-16
6.	Troubleshooting .....	6-1
6.1	Error messages.....	6-2
6.2	Quick diagnosis .....	6-6
7.	Maintenance .....	7-1
7.1	Introduction .....	7-2
7.2	Daily maintenance .....	7-2
7.3	Storage, repacking, and transportation .....	7-2
7.4	Check the firmware version number.....	7-3
7.5	Performance testing.....	7-4
7.5.1	Introduction .....	7-4
7.5.2	Testing output voltage setting accuracy .....	7-5
7.5.3	Testing line regulation .....	7-6
7.5.4	Testing load regulation .....	7-7
7.5.5	Testing current-monitor accuracy .....	7-8

---

## Contents

---

7.6	Calibration .....	7-9
8.	Specifications.....	8-1
8.1	Regulator type .....	8-2
8.2	Output characteristics .....	8-2
8.3	Limit function of setting output voltage .....	8-3
8.4	Current monitor .....	8-3
8.5	Power supply .....	8-3
8.6	Interface for remote control .....	8-4
8.7	Others.....	8-4
8.7.1	Output common terminal (COM) .....	8-4
8.7.2	Enclosure terminal (CHASSIS) .....	8-4
8.7.3	Insulation resistance .....	8-4
8.7.4	Withstanding voltage.....	8-4
8.7.5	Protection function .....	8-5
8.7.6	Setting of power on .....	8-5
8.7.7	Environmental conditions .....	8-5
8.7.8	Dimensions and weight.....	8-5
8.7.9	Standards .....	8-5
8.8	External dimensions.....	8-6
9.	Typical data.....	9-1
9.1	Typical data.....	9-2
9.2	Output noise voltage density frequency characteristics.....	9-2
9.3	Time stability .....	9-3
9.4	Temperature coefficients .....	9-4

---

## Figures

---

	Page
Figure 1-1 Block diagram.....	1-3
Figure 2-1 Assembly diagram of rack mounting kit (EIA for 1 unit).....	2-5
Figure 2-2 Assembly diagram of rack mounting kit (EIA for 2 units).....	2-6
Figure 2-3 Assembly diagram of rack mounting kit (JIS for 1 unit).....	2-7
Figure 2-4 Assembly diagram of rack mounting kit (JIS for 2 units).....	2-8
Figure 2-5 Dimensions of rack mounting kit (EIA for 1 unit).....	2-9
Figure 2-6 Dimensions of rack mounting kit (EIA for 2 units).....	2-10
Figure 2-7 Dimensions of rack mounting kit (JIS for 1 unit).....	2-11
Figure 2-8 Dimensions of rack mounting kit (JIS for 2 units).....	2-12
Figure 2-9 Appearance of fuse holder and direction of fuse insertion.....	2-15
Figure 2-10 LCD example at startup.....	2-16
Figure 2-11 Initial display of LCD example.....	2-16
Figure 2-12 Connection when checking output voltage.....	2-17
Figure 3-1 Front panel.....	3-2
Figure 3-2 Rear panel.....	3-2
Figure 4-1 Display example at startup.....	4-2
Figure 4-2 Initial display of LCD example.....	4-2
Figure 4-3 Panel operation menu tree.....	4-3
Figure 4-4 Cursor display example-1.....	4-4
Figure 4-5 Cursor display example-2.....	4-4
Figure 4-6 Initial display example.....	4-4
Figure 4-7 Top menu display example.....	4-5
Figure 4-8 Display example of output voltage setting menu.....	4-5
Figure 4-9 Display example when setting the negative limit voltage.....	4-6
Figure 4-10 Display example when setting the negative limit voltage (when press up key).....	4-6
Figure 4-11 Display example when setting the negative limit voltage (when press down key).....	4-6
Figure 4-12 Display example when setting the negative limit voltage (when press left key).....	4-6
Figure 4-13 Display example when setting the negative limit voltage (when press right key).....	4-6
Figure 4-14 Display example when setting the positive output voltage.....	4-7
Figure 4-15 Display example when setting the negative output voltage.....	4-8
Figure 4-16 Display example when setting the positive limit voltage.....	4-9
Figure 4-17 Display example when setting the negative limit voltage.....	4-10
Figure 4-18 Display example of setting the remote control.....	4-11
Figure 4-19 Display example after selecting USB.....	4-11
Figure 4-20 Example to indicate VENDOR ID.....	4-11
Figure 4-21 Example to indicate PRODUCT ID.....	4-12
Figure 4-22 Display example after selecting RS-232.....	4-13
Figure 4-23 Display example when setting the baud rate.....	4-13
Figure 4-24 Display example when setting the parity.....	4-14
Figure 4-25 Display example when setting the handshake.....	4-14
Figure 4-26 Display example when setting the terminator.....	4-15

---

## Figures

---

Figure 4-27 Display example after selecting LAN .....	4-16
Figure 4-28 Display example when updating settings .....	4-16
Figure 4-29 Example to indicate the MAC address .....	4-16
Figure 4-30 Display example when setting the IP address.....	4-17
Figure 4-31 Display example when setting subnet mask.....	4-17
Figure 4-32 Display example when setting default gateway.....	4-17
Figure 4-33 Display example when updating settings .....	4-17
Figure 4-34 Example to indicate the port number .....	4-18
Figure 4-35 Display example of UTILITY menu-1 .....	4-19
Figure 4-36 Display example of UTILITY menu-2 .....	4-19
Figure 4-37 Display example when setting “Vout MODE”.....	4-19
Figure 4-38 Display example when setting “Vset MODE”.....	4-20
Figure 4-39 Display example when setting “POW ON Vout” .....	4-21
Figure 4-40 Display example when setting “LCD LIGHT” .....	4-21
Figure 4-41 Display example when setting “LCD CONTRAST” .....	4-22
Figure 4-42 Display example of “INITIALIZE” menu.....	4-23
Figure 4-43 Example to indicate the product information (model) .....	4-24
Figure 4-44 Example to indicate the product information (serial number) .....	4-24
Figure 4-45 Example to indicate the firmware version.....	4-24
Figure 4-46 Example to indicate the last calibration date.....	4-25
Figure 5-1 Pin assignment of RS-232 connector.....	5-4
Figure 5-2 Display example during remote control.....	5-8
Figure 6-1 Display example of error message.....	6-2
Figure 7-1 Display example at startup.....	7-3
Figure 7-2 Display example of firmware version .....	7-3
Figure 7-3 Diagram of connection when testing voltage setting accuracy .....	7-5
Figure 7-4 Diagram of connection when testing line regulation .....	7-6
Figure 7-5 Diagram of connection when testing load regulation.....	7-7
Figure 7-6 Diagram of connection when testing current-monitor accuracy .....	7-8
Figure 8-1 External dimensions .....	8-6
Figure 9-1 Output noise voltage density frequency characteristics .....	9-2
Figure 9-2 Time stability.....	9-3
Figure 9-3 Temperature coefficients (positive output).....	9-4
Figure 9-4 Temperature coefficients (negative output) .....	9-4

---

## Tables

---

	Page
Table 4-1 Settings after initialization .....	4-23
Table 4-2 LCD settings after initialization .....	4-26
Table 5-1 RS-232 pin assignment .....	5-4
Table 5-2 The header list of commands .....	5-10
Table 6-1 General error list .....	6-2
Table 6-2 Error list of panel operation .....	6-3
Table 6-3 Error list of internal memory .....	6-4
Table 6-4 Error list of remote control .....	6-5
Table 6-5 Serious error list .....	6-5
Table 6-6 Troubleshooting .....	6-6
Table 7-1 Measurement instrument list .....	7-4
Table 7-2 Judgement for voltage setting accuracy .....	7-5
Table 7-3 Judgement for line regulation .....	7-6
Table 7-4 Judgement for load regulation .....	7-7
Table 7-5 Judgement for current-monitor accuracy .....	7-8
Table 8-1 Fuse rating .....	8-3



# 1. Outline

1.1	Overview.....	1-2
1.2	Features.....	1-2
1.3	Operation principles.....	1-2
1.4	Block diagram.....	1-3

---

## 1.1 Overview

“LP6016-01” is a LOW NOISE DC VOLTAGE SOURCE that achieves output noise of 10  $\mu\text{Vrms}$  or lower (Bandwidth: 10 Hz to 20 MHz) and output voltage stability of  $\pm 10$  ppm/ $^{\circ}\text{C}$ .

It has both positive and negative voltage outputs. The output voltage can be adjusted in the range of 0 to  $\pm 16.1$  V by manual operation or remote PC control. The maximum output current is  $\pm 100$  mA.

## 1.2 Features

- (1) The output noise is ultra low with 10  $\mu\text{Vrms}$  or lower (Bandwidth: 10 Hz to 20 MHz).
- (2) The output voltage stability is  $\pm 10$  ppm/ $^{\circ}\text{C}$  or lower.
- (3) High accuracy voltage setting with  $\pm$  ( $| 0.03$  % of setting  $| + 250$   $\mu\text{V}$ ) is available.
- (4) Three types of remote interfaces are selectable (USB, RS-232, and LAN). And measurement system can be configured.
- (5) The output section is isolated from the chassis ( $\pm 42$  Vpk) to prevent GND loop generation.
- (6) The power supply voltage can be selected from AC 100, 120, 220, and 240 V by using the VOLTAGE SELECTOR switch on the rear panel.
- (7) The output current can be measured using current-monitor outputs.

## 1.3 Operation principles

This product is constructed with an analog system using a power transformer, series regulator, and so on, so switching noise does not exist. It consists of a voltage reference and amplifier circuit with low noise and high stability, and the output voltage is controlled by changing the reference voltage with the D/A converter.

Although it includes a digital circuit, such as an D/A converter, and a circuit of remote control, insulation and shield are designed so that noise caused by them are not superimposed on the output.



## 1.4 Block diagram

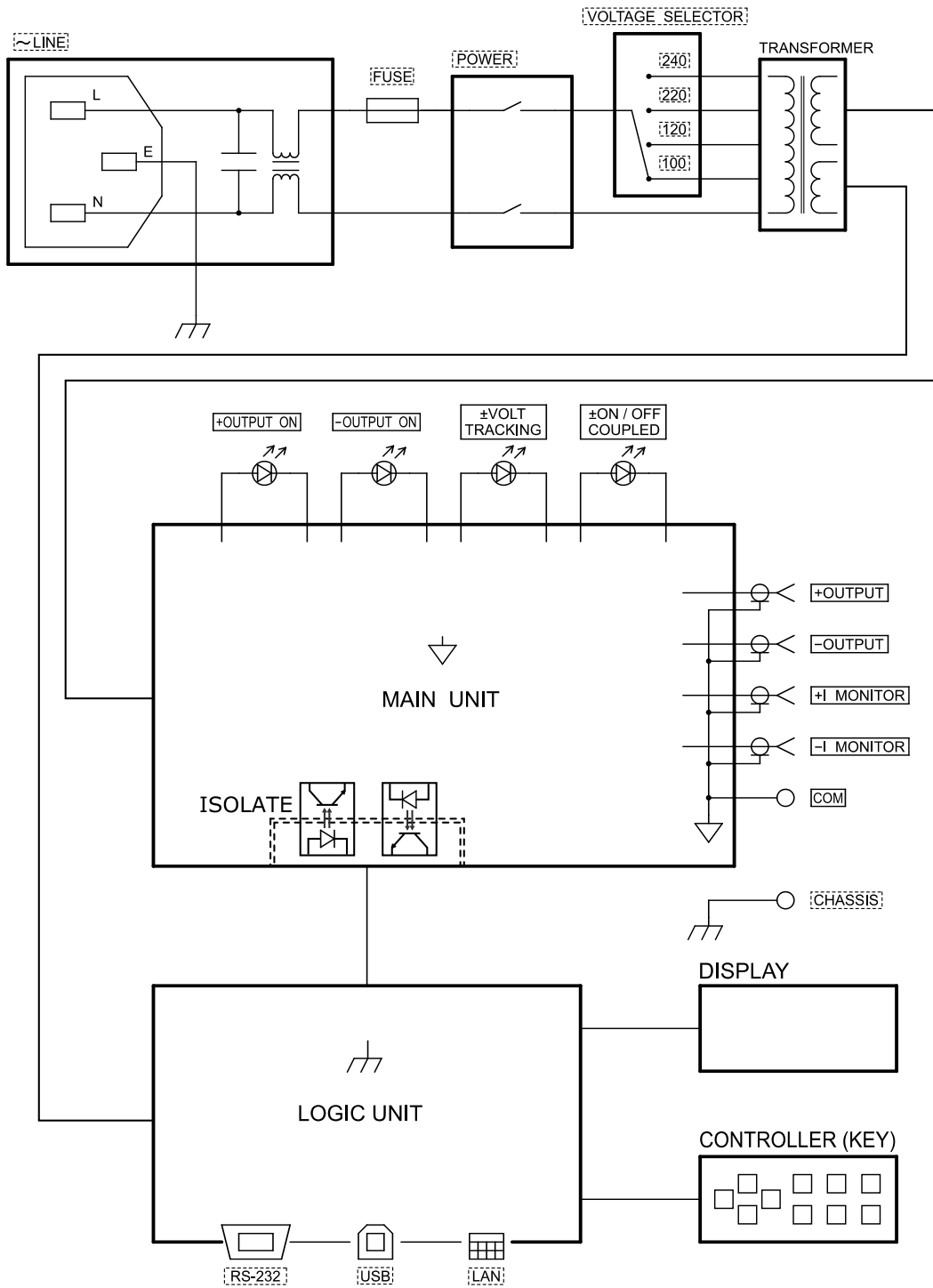

Figure 1-1 Block diagram



## 2. Preparation before use

2.1	Checking before use .....	2-2
2.2	Installation .....	2-3
2.2.1	General cautions .....	2-3
2.2.2	Installation environment .....	2-3
2.2.3	Rack mounting .....	2-4
2.3	Grounding and Power Connections .....	2-13
2.4	Quick operation check .....	2-16
2.4.1	Check operation at power on .....	2-16
2.4.2	Check the output voltage .....	2-17

## 2.1 Checking before use

### ■ Safety check

To ensure safe use, read the following sections of this instruction manual.

- "Safety Precautions" (at the beginning of this instruction manual)
- "2.3 Grounding and Power Connections"

### ■ Check the appearance and accessories

If there is an abnormal appearance (scratches, dents, etc.) on the outside of the cardboard box, check whether this product is affected when removing the product from the box.

When you have removed the contents from the packing box, check their condition.

If you find a scratch on this product or an accessory is missing, contact NF Corporation or an authorized agent.

#### ● Appearance check

Check that there are no scratches or dents on the panel surfaces, connectors, etc.

#### ● Product configuration check

The following shows the product configuration. Check that the quantities are correct and there are no scratches.

● LP6016-01 Main unit .....	1
● Accessories	
Instruction manual .....	1
Power cord set (2 m, 3-pole) .....	1
Fuse (spare) .....	1

#### ● Options

PA-001-3089: BNC - Binding post conversion adaptor

PA-001-3230: Rack mount kit (EIA, for 1 unit)

PA-001-3090: Rack mount kit (EIA, for 2 units)

PA-001-3231: Rack mount kit (JIS, for 1 unit)

PA-001-3091: Rack mount kit (JIS, for 2 units)

### WARNING

To prevent exposure to high voltages, never open the case of this product.

Even when inspection inside this product is needed, only service engineers certified by NF Corporation should touch the inside.

## 2.2 Installation

### 2.2.1 General cautions

- If you use it with the back side down or side down, it may fall over. Be sure to install it so that all four rubber feet on the bottom come into contact with a flat surface such as a desk.
- If this product is used in a residential area, it may generate electromagnetic fields and affect other equipment. To prevent interference with reception of radio and television broadcasting, ensure appropriate measures to reduce electromagnetic radiation.
- Avoid using this product in environments where there is strong radio-frequency electromagnetic radiation. When using this product in such environments, the noise performance of this product may temporarily worsen.

### 2.2.2 Installation environment

- Place this product in a location that satisfies the following conditions.  
Operation: 0 to +50 °C, 5 to 85 %RH (absolute humidity 1 to 25 g/m<sup>3</sup>, no condensation)  
Storage: -10 to +60 °C, 5 to 95 %RH (absolute humidity 1 to 29 g/m<sup>3</sup>, no condensation)
- Place the product in a location at an altitude of 2000 m or less.

---

## CAUTIONS

---

Avoid installation in the following locations.

- Where there is flammable gas  
There is a risk of explosion. Never install or use it in such a location.
  - Outdoors, where exposed to direct sunlight or near fire or a heat source.  
The performance may not be sufficient or failure may occur.
  - Where there are corrosive gases and vapors, a large amount of dust and particles, salty air, oily smoke, metal powder, etc.  
Corrosion or malfunction may occur.
  - Where there is a large amount of vibration.  
Malfunction or failure may occur.
  - Near an electromagnetic field source, high-voltage equipment, power line, or pulse noise source.  
Malfunction or failure may occur.
-

### 2.2.3 Rack mounting

This product can be installed in an IEC or EIA standard rack, or a JIS standard rack by using the appropriate optional rack mounting kit. Rack mounting kits are available for millimeter racks (JIS) and inch racks (EIA).

First, assemble the rack mounting kit as shown in Figure 2-1 to Figure 2-8 then install the product in the rack.

---

#### **WARNING**

When mounting this product in a rack, be sure to use a rack rail or other means and support the product. Failure to do so, may result in injury to yourself or damage to this product due to it falling.

---

---

#### **CAUTIONS**

Provide sufficient ventilation holes in the rack or air cooling with a cooling fan.

If the ambient temperature exceeds the specification, performance may decrease and output may stop due to overheat protection.

---

## 2.2 Installation

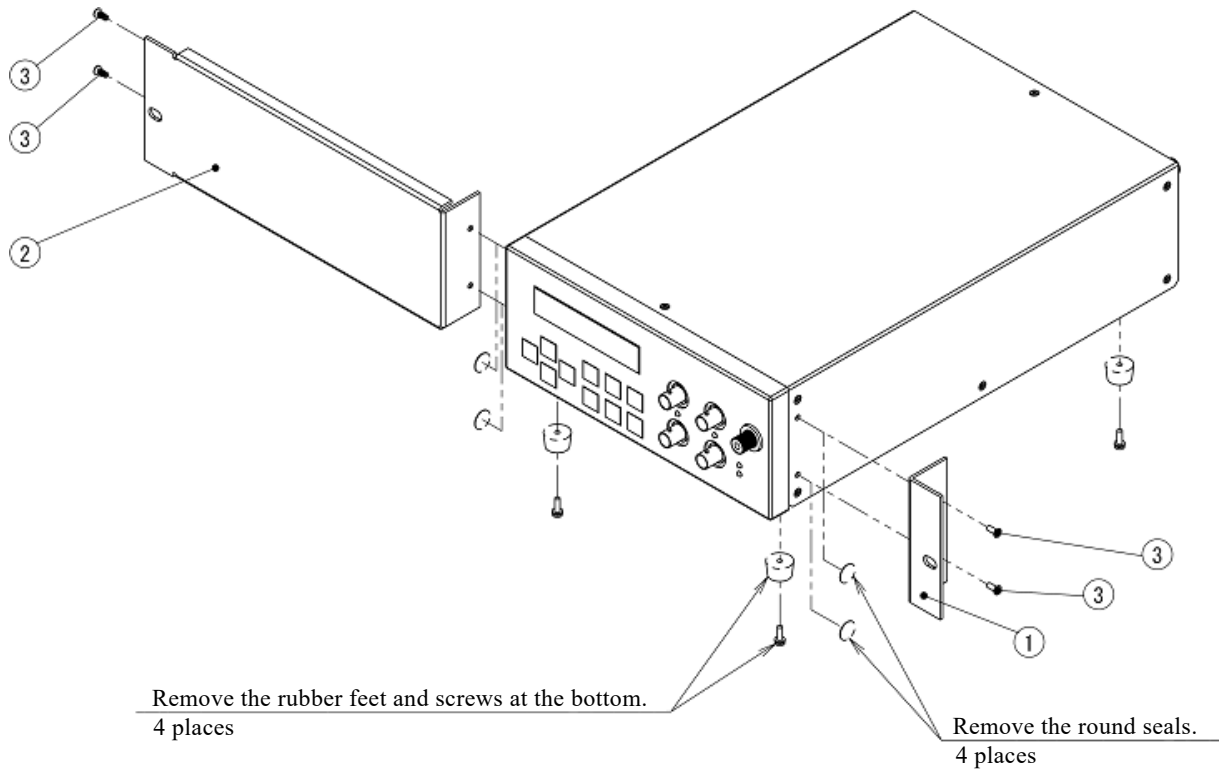

No.	Item	Quantity
1	L-shaped bracket	1
2	Spacer bracket	1
3	Countersunk screw (M3×8)	4

Figure 2-1 Assembly diagram of rack mounting kit (EIA for 1 unit)

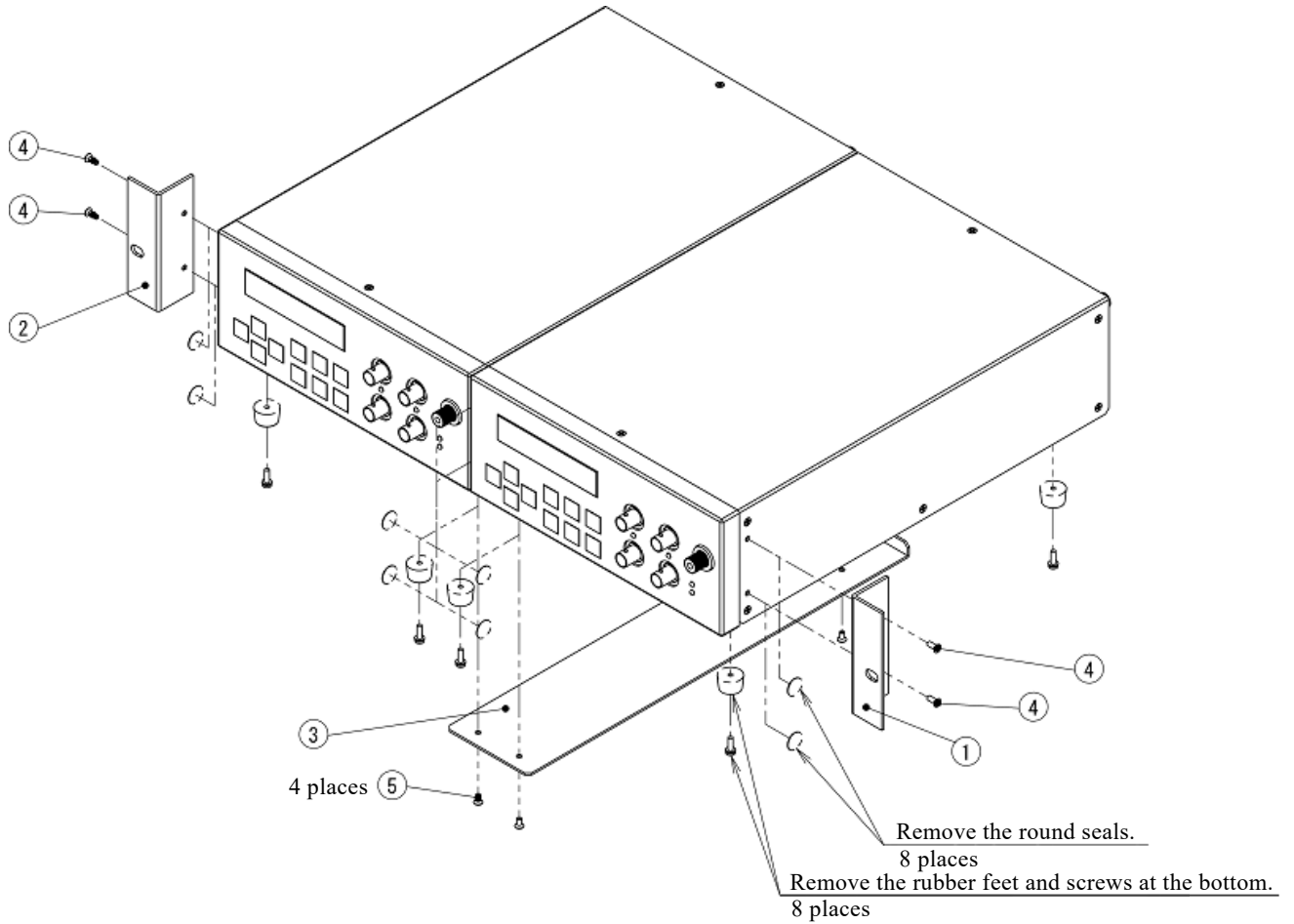

No.	Item	Quantity
1	L-shaped bracket-1	1
2	L-shaped bracket-2	1
3	Connection fitting	1
4	Countersunk screw (M3×8)	4
5	Countersunk screw (M3×6)	4

Figure 2-2 Assembly diagram of rack mounting kit (EIA for 2 units)



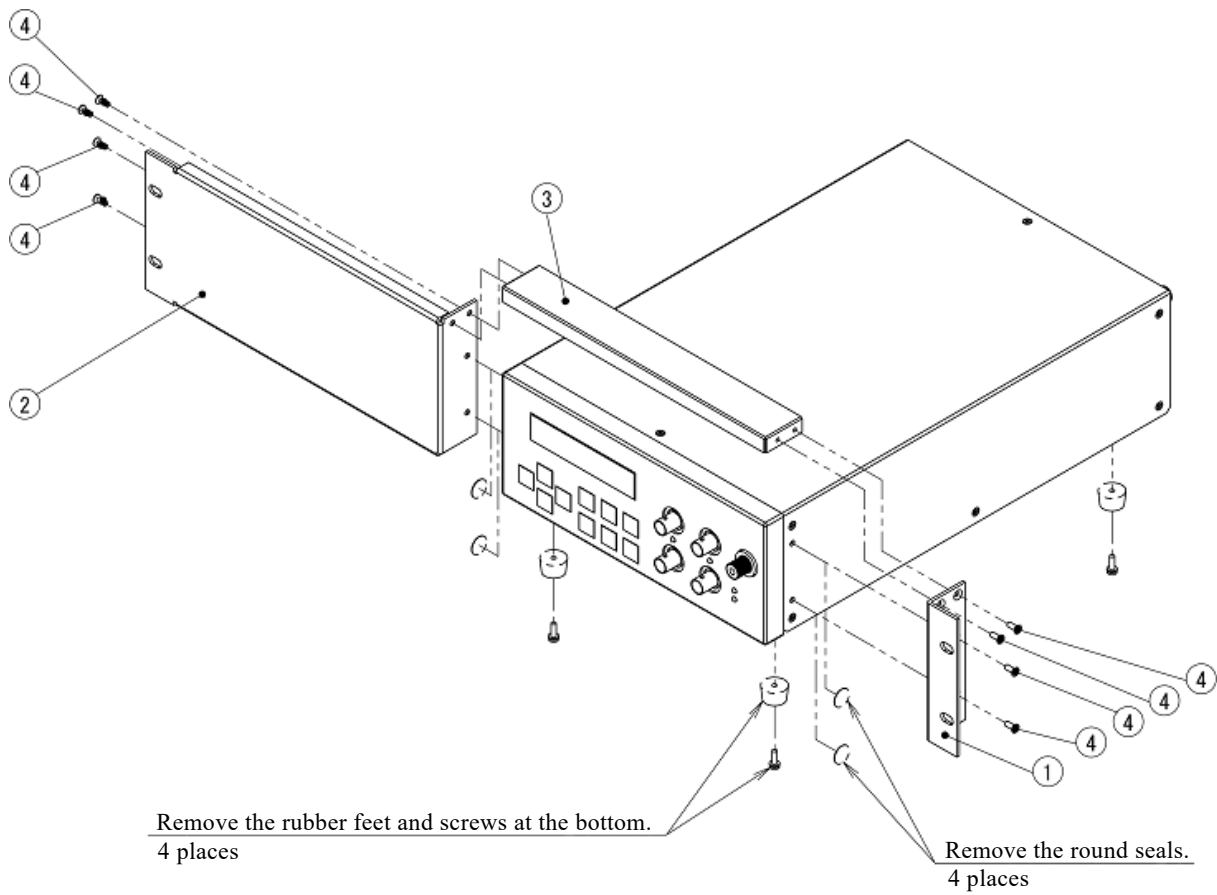

No.	Item	Quantity
1	L-shaped bracket	1
2	Spacer bracket-1	1
3	Spacer bracket-2	1
4	Countersunk screw (M3×8)	8

Figure 2-3 Assembly diagram of rack mounting kit (JIS for 1 unit)

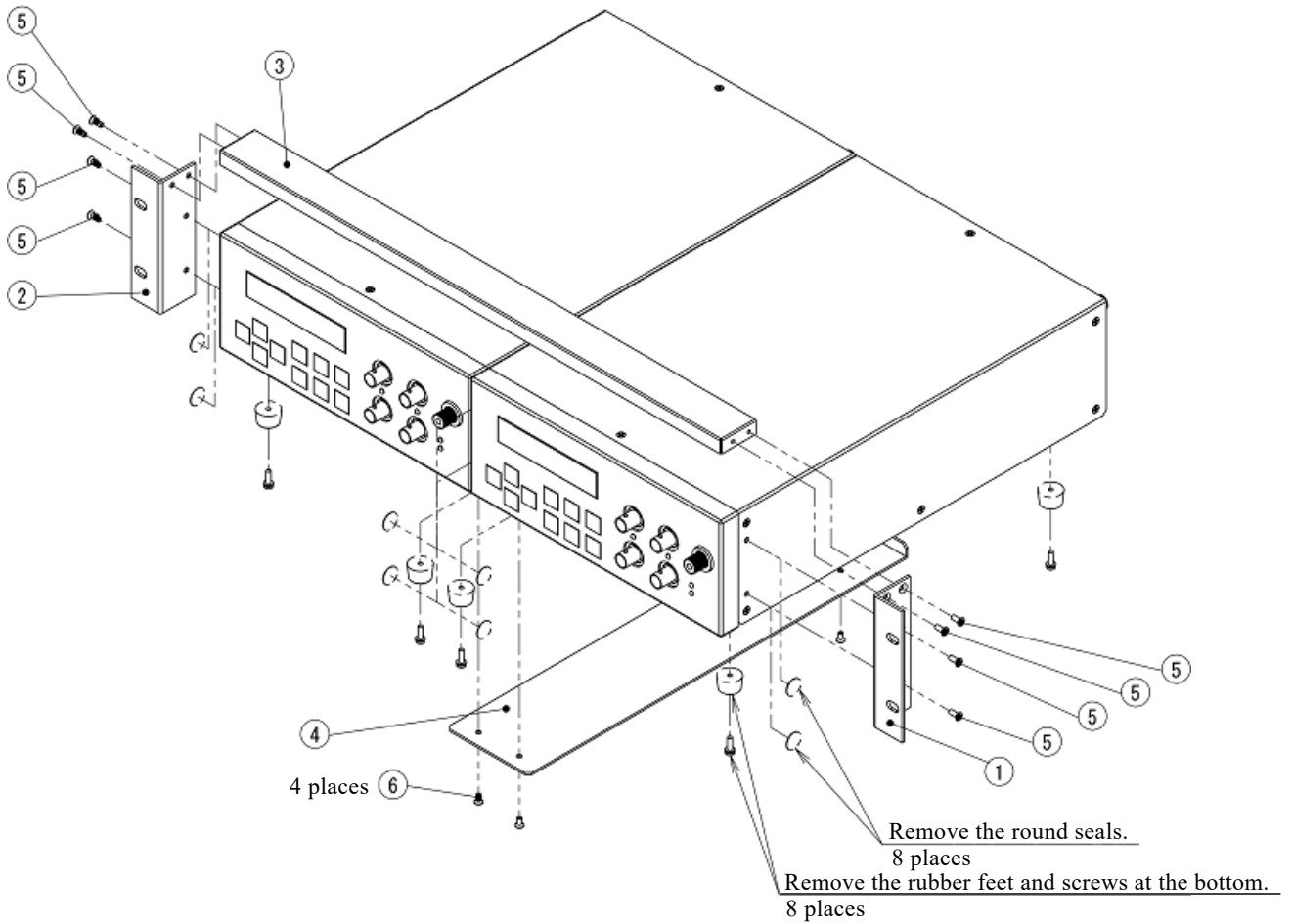

No.	Item	Quantity
1	L-shaped bracket-1	1
2	L-shaped bracket-2	1
3	Spacer bracket	1
4	Connection fitting	1
5	Countersunk screw (M3×8)	8
6	Countersunk screw (M3×6)	4

Figure 2-4 Assembly diagram of rack mounting kit (JIS for 2 units)

## 2.2 Installation

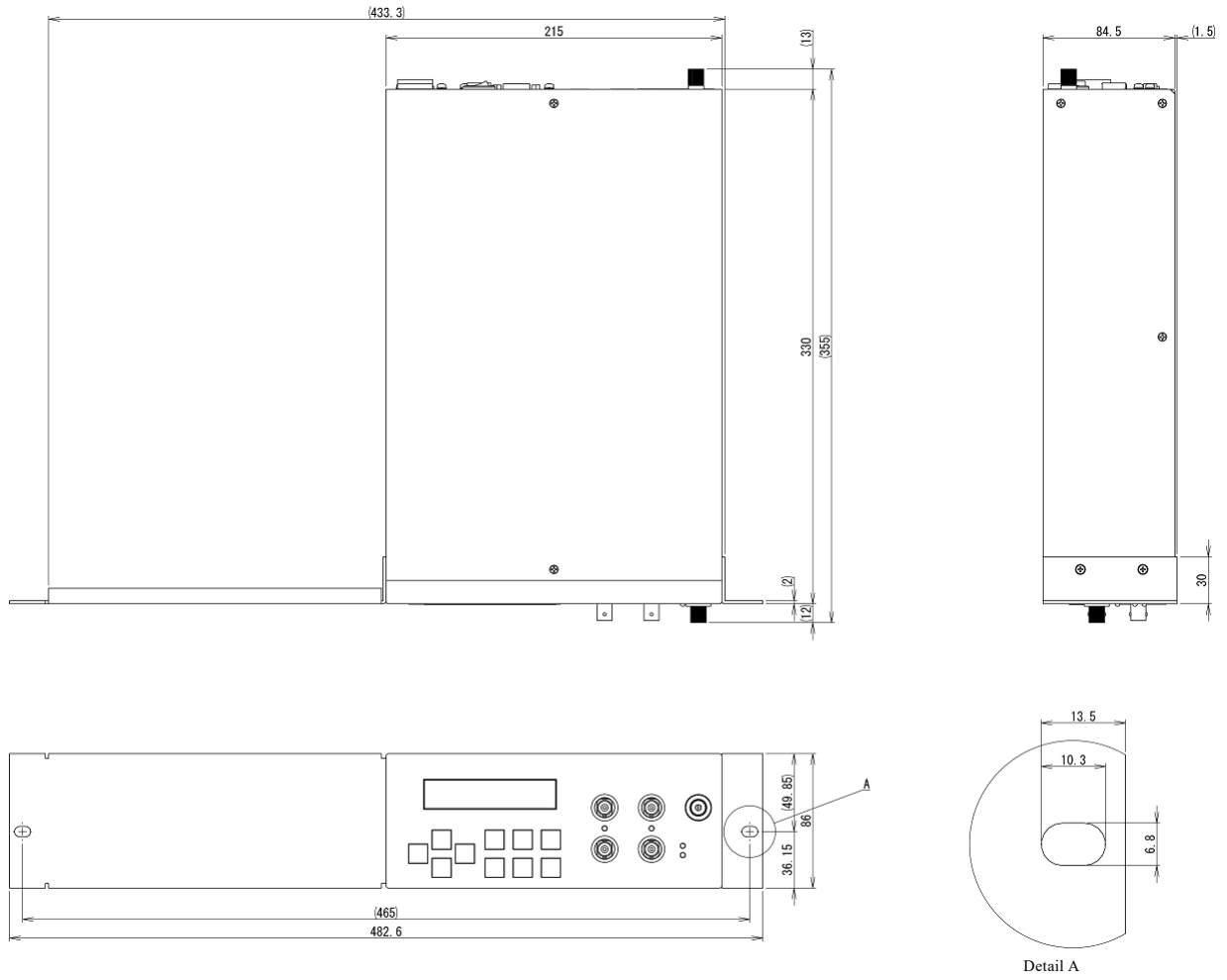

Figure 2-5 Dimensions of rack mounting kit (EIA for 1 unit)

## 2.2 Installation

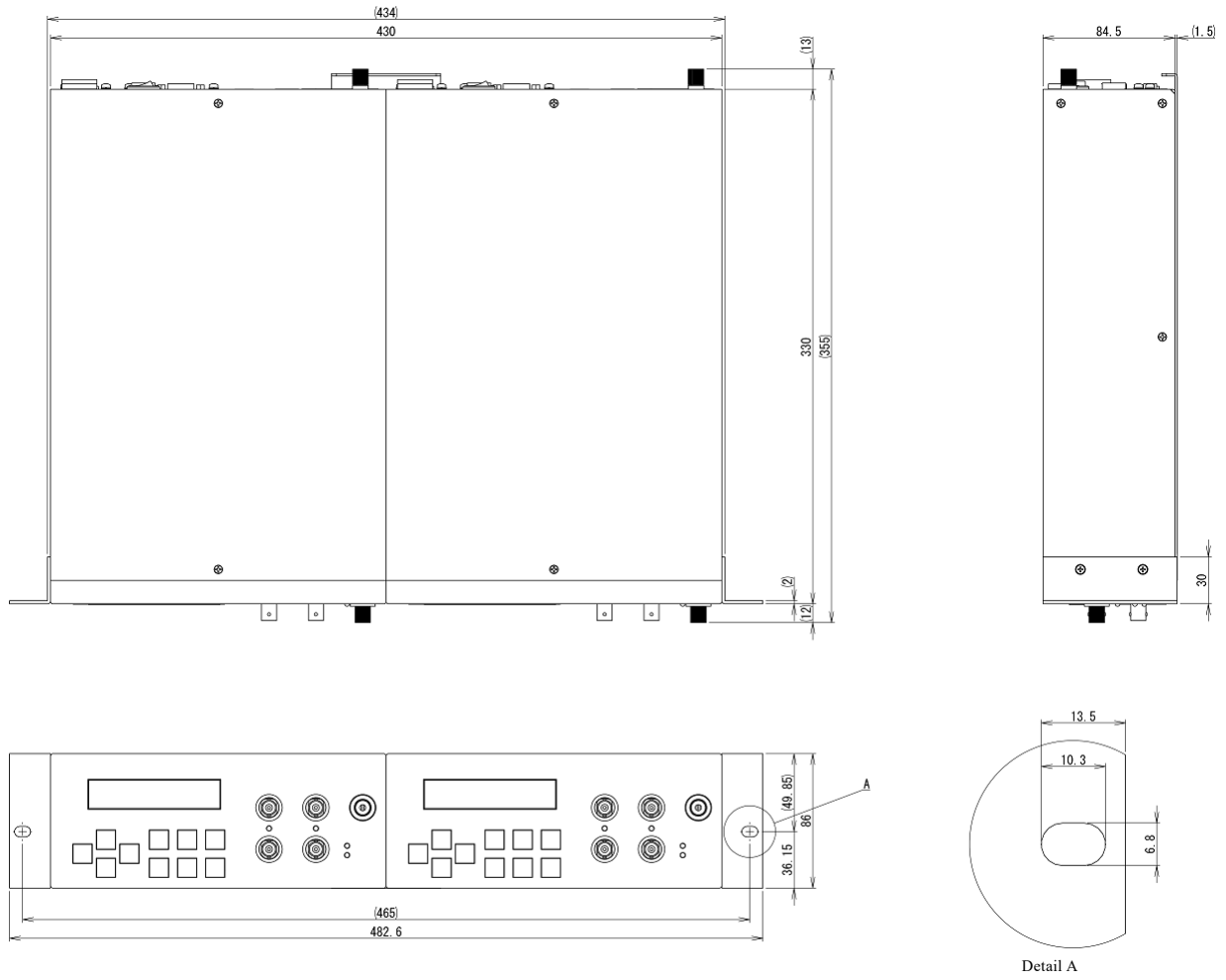

Figure 2-6 Dimensions of rack mounting kit (EIA for 2 units)

## 2.2 Installation

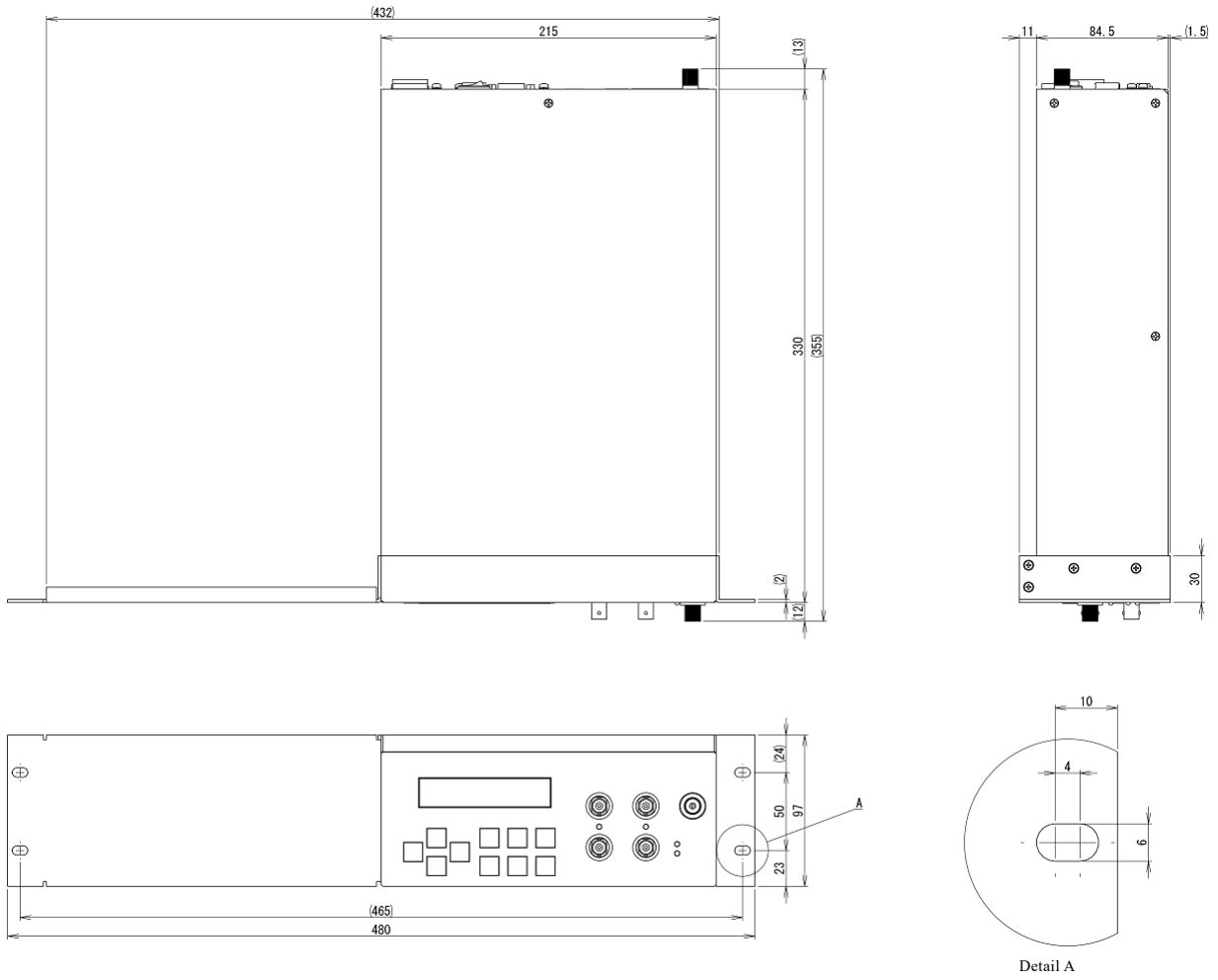

Figure 2-7 Dimensions of rack mounting kit (JIS for 1 unit)

## 2.2 Installation

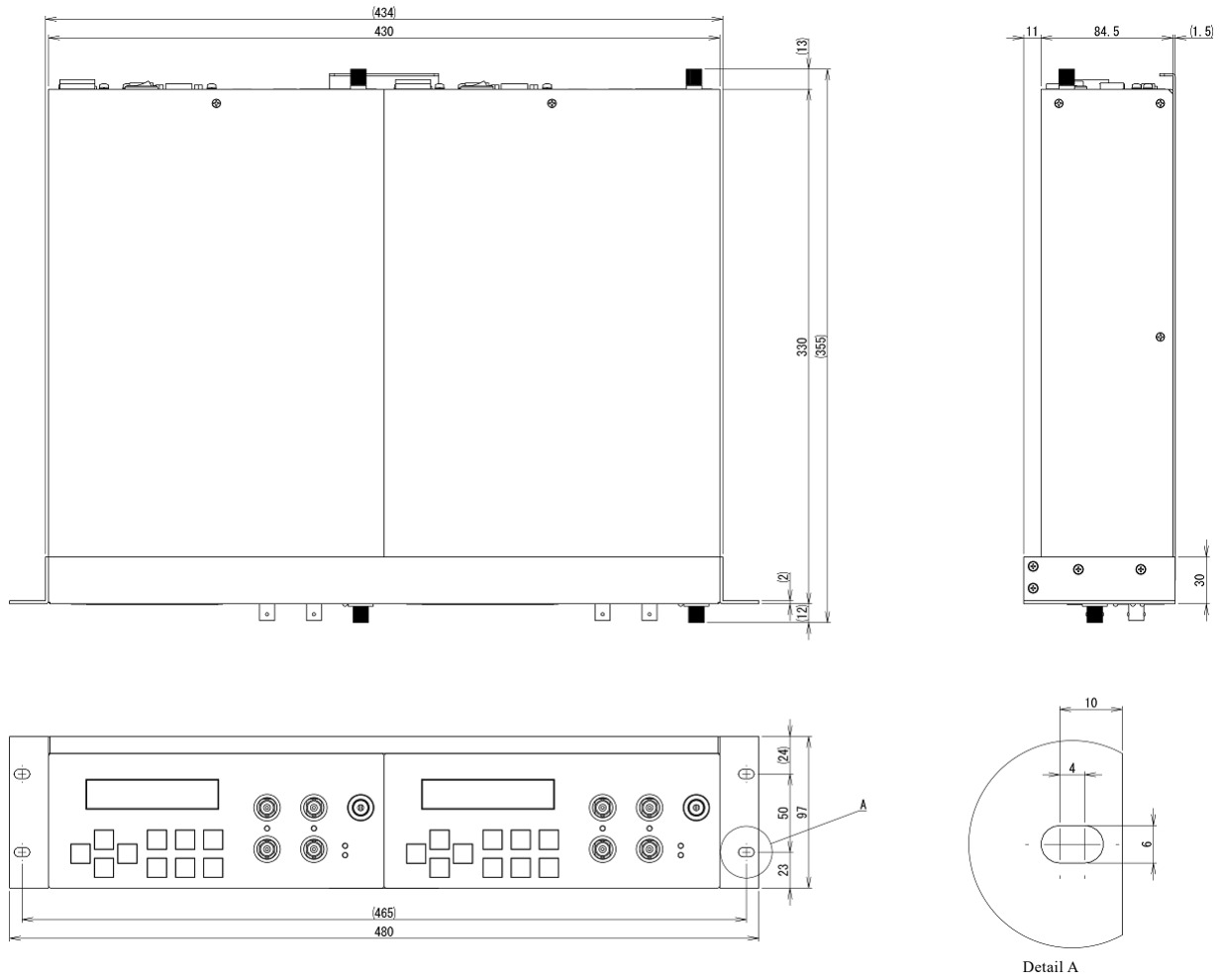

Figure 2-8 Dimensions of rack mounting kit (JIS for 2 units)

## 2.3 Grounding and Power Connections

### ■ Ensure that this product is grounded

This product is automatically grounded by connecting a 3-pole power plug to a power outlet with a protective ground contact.

This product does not come with a 3-pole to 2-pole conversion adapter.

If you must use a 3-pole to 2-pole conversion adapter, be sure to connect the ground line of the adapter to a suitable ground near the power outlet.

---

### **WARNING**

There is risk of electrical shock if this product is not grounded.

To prevent electrical shock, connect it to an earth ground so that ground resistance is 100  $\Omega$  or less.

---

### ■ Power supply specifications

Voltage range: AC 100, 120, 220 or 240 V  $\pm 10\%$ , not to exceed AC 250 V.

Frequency range: 50/60 Hz  $\pm 2$  Hz

Power consumption: 28 VA or lower

Overvoltage category: II

### ■ How to switch the power supply voltage

This product has a power supply voltage selector switch on the rear panel.

Check that the voltage of the outlet matches the voltage set with the power supply voltage selector switch.

To select the power supply voltage, disconnect the power cord then slowly turn the selector switch with a coin-driver.

---

### **CAUTIONS**

To prevent the power supply voltage selector switch from being in a half-way position, set the switch to the position to where it clicks.

---

### ■ Connecting the power supply

- 1) Confirm that the power supply voltage to which this product is connected is within the specified voltage range of this product.
- 2) Set the power switch on the rear panel to the off position.
- 3) Insert the power cord into the power inlet that is on the rear panel.
- 4) Plug the power cord into a ground-protected power outlet.

---

### CAUTIONS

---

The power cord set that comes with this product is intended for use only with this product.

The power cord set should not be used with any other product or for any other purpose.

When connecting this product to the power supply, be sure to use only the power cord that is provided with this product.

---

■ In an emergency, the power cord can be used to disconnect this product from the power supply.

---

### WARNING

---

Confirm that there is sufficient space around the power inlet of this product to ensure that the power cord can be removed easily.

Alternatively, plug the power cord into a power outlet that is easily accessible and has sufficient space around it to allow easy removal of the power plug.

---



■ **Observe the rating of the power fuse.**

The following shows the ratings of the power fuse of this product.

100/120 V: Time lag 0.4 A, Rated voltage 250 V,  $\phi$  5.2 × 20 mm

220/240 V: Time lag 0.2 A, Rated voltage 250 V,  $\phi$  5.2 × 20 mm

■ **Replace the fuse**

To replace the fuse, disconnect the power cord then turn the fuse holder on the rear panel counterclockwise with a screwdriver and pull it out. Replace the old fuse with a new one, insert the fuse holder, and turn it clockwise with a screwdriver to lock it.

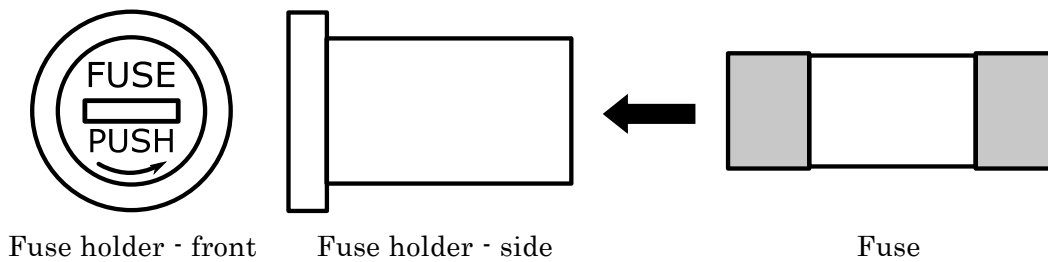

Figure 2-9 Appearance of fuse holder and direction of fuse insertion

---

**⚠ WARNING**

There is risk of fire or other accidents. Use a fuse of the same rating when replacing the old fuse. Before replacing the fuse, be sure to disconnect the power plug from the outlet.

---

## 2.4 Quick operation check

When using this product for the first time or when using it again after a long time, we recommend checking the operation with the following procedure.

Refer to “3. Explanations of the panel” and “4. Operation procedure” for panel operation and various setting methods during operation check.

### 2.4.1 Check operation at power on

With only the power cord connected to this product, turn on the power switch on the rear panel.

The internal check at startup starts automatically, and a message is displayed on the LCD during this check (about 3 seconds), as shown in Figure 2-10.

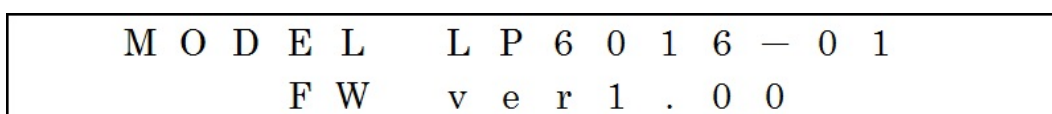

Figure 2-10 LCD example at startup

When the internal check is completed, a message is displayed on the LCD, as shown in Figure 2-11. Check that an error message, "OHP" or "OCP", is not displayed on the LCD.

If such an error message is displayed, refer to “6.1 Error messages” and take appropriate action.

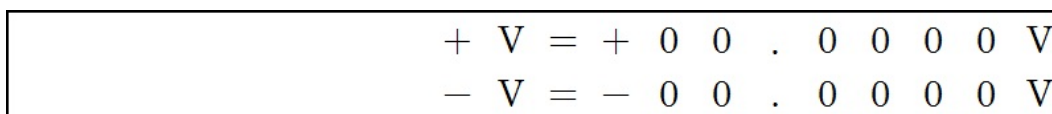

Figure 2-11 Initial display of LCD example

### 2.4.2 Check the output voltage

For checking the output voltage, use a DC voltmeter (such as a multimeter).

In this example, check by setting the positive and negative output voltages to +10.0000 V and -10.0000 V. Depending on the output voltage to be used, set the voltage to be checked.

Connect the devices as shown in Figure 2-12. Set the positive and negative output voltages to +10.0000 and -10.0000 V and turn on the output.

Check that the orange LED indicating that the output state is ON is lit. Also check that the voltages measured by the DC voltmeter are about +10 and -10 V.

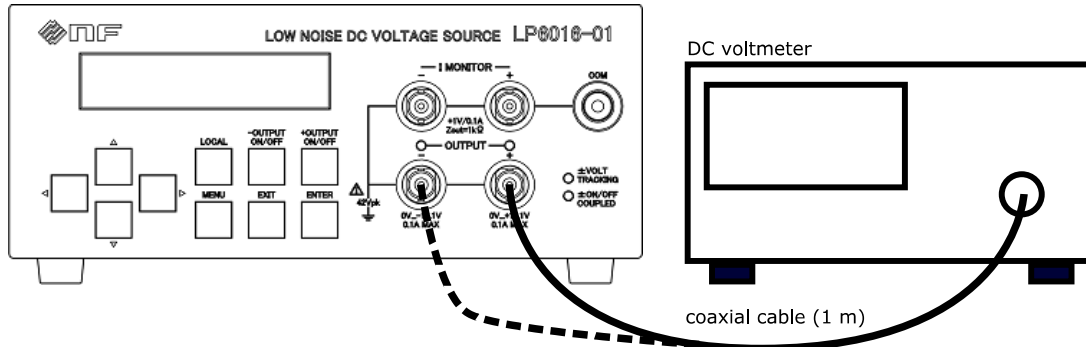

Figure 2-12 Connection when checking output voltage  
(When checking on the negative side, connect with the broken line.)



## 3. Explanations of the panel

3.1	Name of each part of the panels .....	3-2
3.1.1	Front panel.....	3-2
3.1.2	Rear panel .....	3-2
3.2	Function of each part of the panels .....	3-3
3.2.1	Front panel.....	3-3
3.2.2	Rear panel .....	3-4

### 3.1 Name of each part of the panels

This section explains the names, functions, and outline of the operation of the front and rear panels.

#### 3.1.1 Front panel

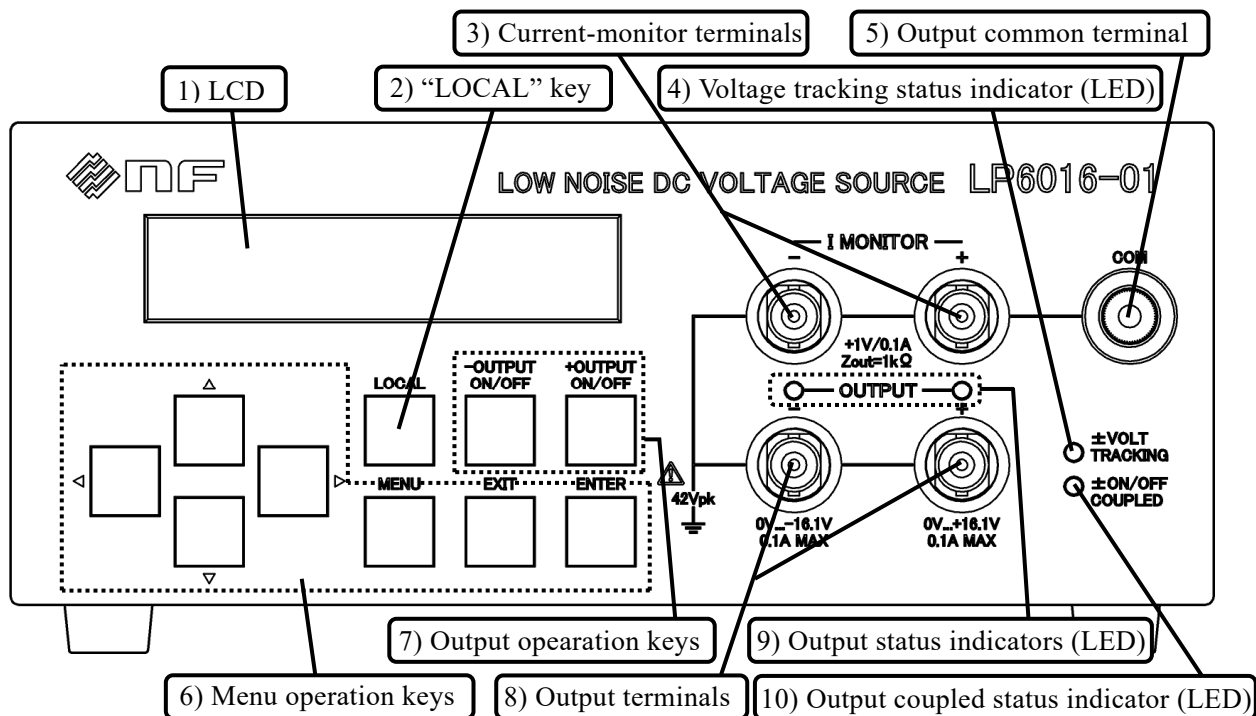

Figure 3-1 Front panel

#### 3.1.2 Rear panel

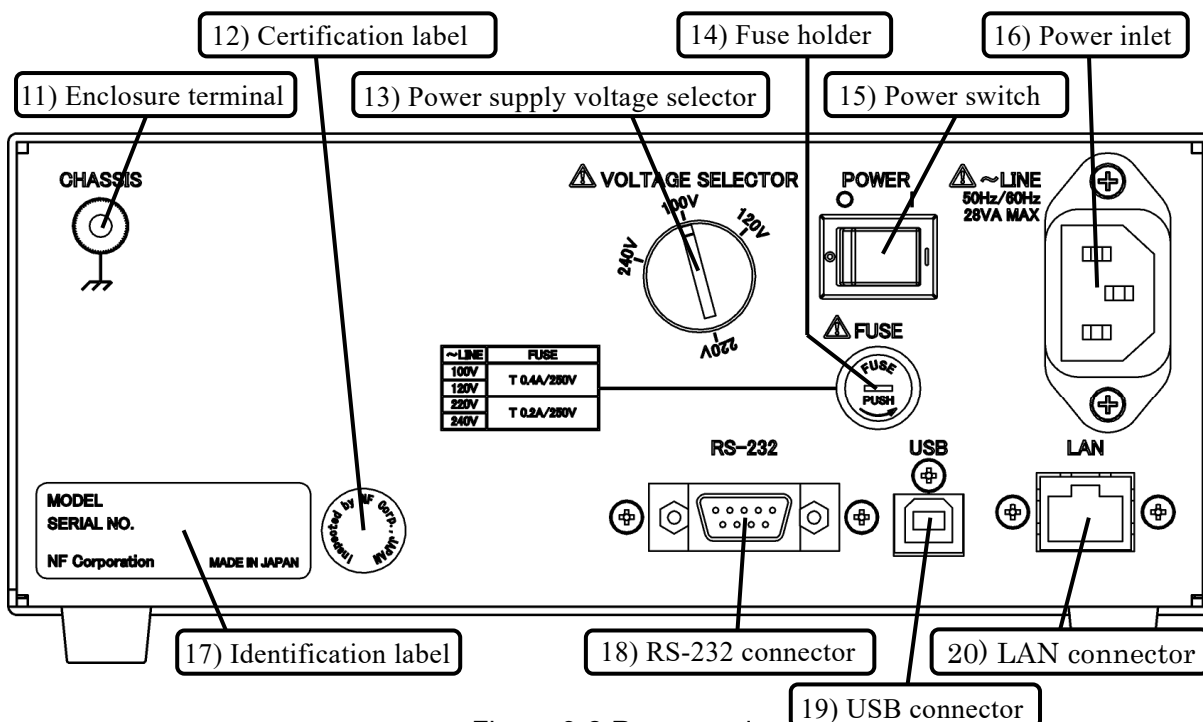

Figure 3-2 Rear panel

## 3.2 Function of each part of the panels

### 3.2.1 Front panel

1) LCD

This displays setting menus, errors, and so on.

2) "LOCAL" key (LOCAL)

This is a key to switch from remote control state to panel operation.

3) Current-monitor terminals (+I MONITOR, -I MONITOR)

They can be used to measure output current. They output voltage with conversion gain of 1 V/100 mA.

There are two BNC receptacle connectors (positive and negative), and their output impedance is about 1 k $\Omega$ .

Ex: When the output current is 100 mA, the output of a current-monitor terminal is 1 V.

4) Voltage tracking status indicator (LED,  $\pm$ VOLT TRACKING)

This is a green LED indicating that the voltage setting mode (Vset MODE) is "TRACKING".

5) Output common terminal (COM)

This is connected to the output common (COM) and corresponds to the banana plug of  $\phi$  4 mm. Wire of  $\phi$  2.5 mm or less can also be connected.

6) Menu operation keys

These keys are used to make settings. There are seven keys: up, down, left, right, MENU, EXIT, and ENTER.

7) Output operation keys (+OUTPUT ON/OFF, -OUTPUT ON/OFF)

They are the keys (positive and negative) to switch output on and off. They switch on and off each time they are pressed.

8) Output terminals (+OUTPUT, -OUTPUT)

There are two BNC receptacle connectors (positive and negative) to output voltage.

9) Output status indicators (LED, +OUTPUT, -OUTPUT)

They are two orange LEDs indicating the output is on. There are two: positive and negative.

10) Output coupled status indicator (LED,  $\pm$ ON/OFF COUPLED)

This is a green LED indicating that the output mode (Vout MODE) is "COUPLED".

### 3.2.2 Rear panel

#### 11) Enclosure terminal (CHASSIS)

This is connected to the enclosure (CHASSIS) and corresponds to the banana plug of  $\phi$  4 mm. Wire of  $\phi$  2.5 mm or less can also be connected.

#### 12) Certification label

This is a label indicating the passing of inspection at NF Corporation.

#### 13) Power supply voltage selector (VOLTAGE SELECTOR)

This is a rotary switch that switches the setting of the power supply voltage. Switch with the coin-driver according to the power supply voltage. To prevent the power supply voltage selector switch from being in a half-way position, set the switch to the position to where it clicks.

#### 14) Fuse holder (FUSE)

This holder stores a fuse that protects this product.

When replacing fuses, follow the rating and do it in the proper manner. For details, see "2.3 Grounding and Power Connections".

#### 15) Power switch (POWER)

This is a switch to switch power supply on and off.

#### 16) Power inlet (~LINE)

This is an inlet for connecting the power supply. Supply the voltage set by the power supply voltage selector. Furthermore, the center pole of the 3-pole plug is a protective ground terminal. Be sure to ground it.

#### 17) Identification label

This label shows the model and serial number of this product.

#### 18) RS-232 connector (RS-232)

This is used for remote control.

Use a crossover cable to connect this product to the controller. For details, refer to "Connection" on page 5-4.

#### 19) USB connector (USB)

This is a USB 2.0 Type B compliant connector used for remote control.

To connect this product to the controller, use the connection cable for the USB 2.0 Type B connector. For details, refer to "Connection" on page 5-2.

#### 20) LAN connector (LAN)

This is a LAN connector used for remote control.

Use a CAT 5e or later compliant cable to connect this product to the controller. For details, refer to "Connection" on page 5-6.



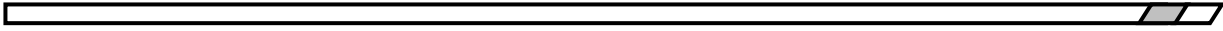



## 4. Operation procedure

4.1	Display and operation for powering up.....	4-2
4.1.1	What to check before turning the power on.....	4-2
4.1.2	Turning power on and off .....	4-2
4.1.3	Setting at power on.....	4-2
4.1.4	Startup behavior and display.....	4-2
4.1.5	Warm-up time .....	4-2
4.2	The list of panel operations and functions.....	4-3
4.2.1	Basic panel operation and display examples .....	4-4
4.2.2	Setting the output voltage (VOLTAGE).....	4-7
4.2.3	Setting the limit voltage (LIMIT) .....	4-9
4.2.4	Setting of the remote control (INTERFACE).....	4-11
4.2.5	Others (UTILITY) .....	4-19
4.3	Operations no included in the menu tree .....	4-26
4.3.1	Switching the output on and off.....	4-26
4.3.2	Switching from remote control state to local operation state .....	4-26
4.3.3	Initialization of the LCD setting .....	4-26
4.4	Connection notes .....	4-27
4.4.1	Output connection.....	4-27
4.4.2	Current-monitor connection.....	4-27

## 4.1 Display and operation for powering up

### 4.1.1 What to check before turning the power on

Before turning the power on, read "2.3 Grounding and Power Connections" and check this product's grounding and power supply voltage.

### 4.1.2 Turning power on and off

This product can be switched on and off by operating the power switch on the rear panel.

### 4.1.3 Setting at power on

The setting state when this product is started will be that when last powered off. However, only the outputs state is set by "Power on setting (POW ON Vout)". For "Setting at power on (POW ON Vout)", refer to "The output state at startup (POW ON Vout)" on page 4-21.

### 4.1.4 Startup behavior and display

The internal check at startup starts automatically, and during this check (about 3 seconds) a message is displayed on the LCD, as shown in Figure 4-1.

<p style="text-align: center;">M O D E L   L P 6 0 1 6 – 0 1 F W   v e r 1 . 0 0</p>
--

Figure 4-1 Display example at startup

When the internal check is completed, a message is displayed on the LCD, as shown in Figure 4-2. Check that an error message, "OHP" or "OCP", is not displayed on the LCD.

If such an error message is displayed, refer to "6.1 Error messages" and take appropriate action.

<p style="text-align: center;">+ V = + 0 0 . 0 0 0 0 V – V = – 0 0 . 0 0 0 0 V</p>
--

Figure 4-2 Initial display of LCD example

### 4.1.5 Warm-up time

The warm-up time for this product is 60 minutes. To satisfy the specifications of "voltage setting accuracy" and "current-monitor accuracy", always warm up.

## 4.2 The list of panel operations and functions

This section explains the panel operations and functions of this product.

The panel operation menu tree is shown in Figure 4-3.

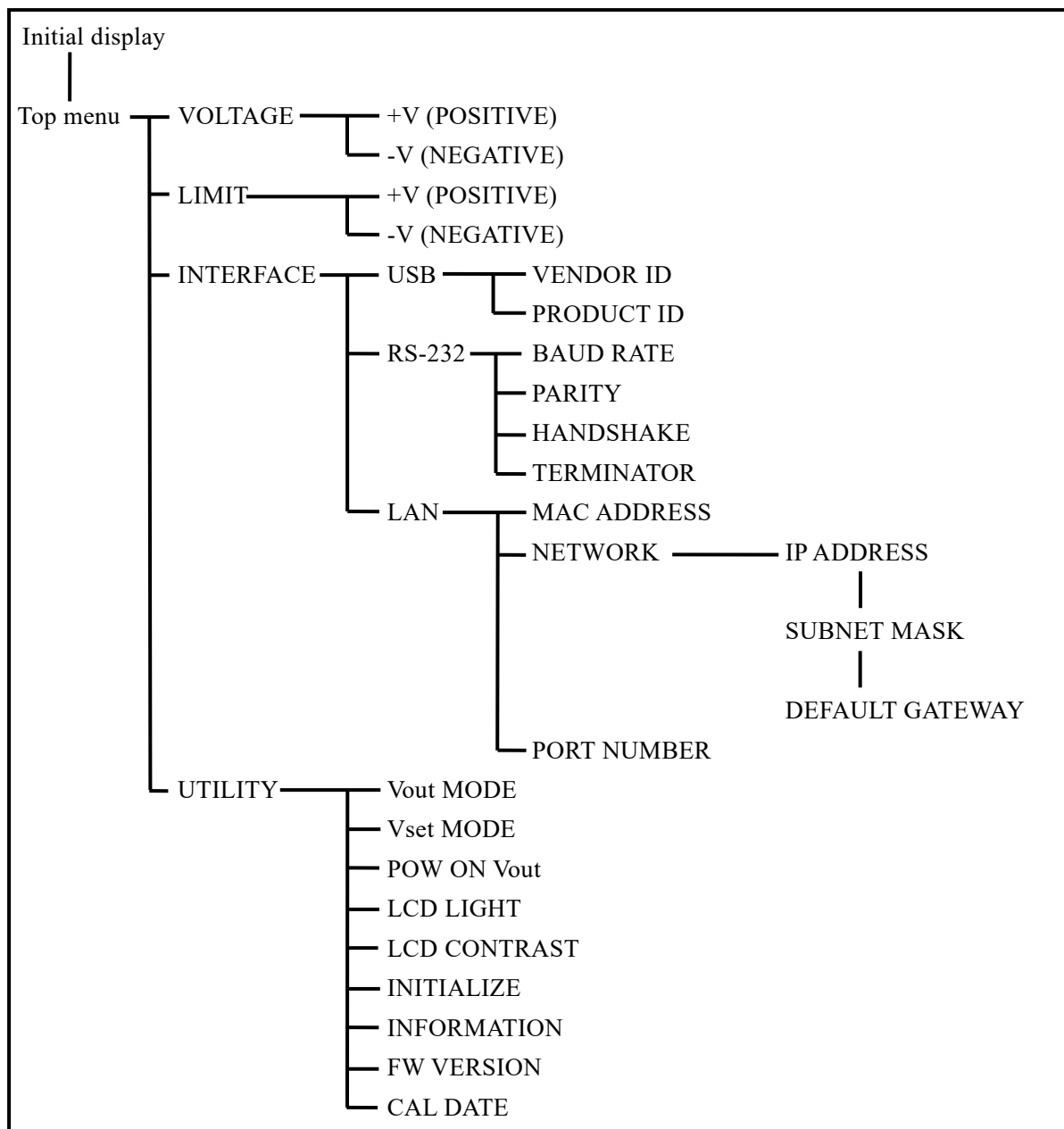

Figure 4-3 Panel operation menu tree

### 4.2.1 Basic panel operation and display examples

This section shows basic panel operation and display examples using menu operation keys.

There are seven menu operation keys (up, down, left, right, MENU, EXIT, ENTER) used when making settings.

- **Cursor and selection symbol**

- The "▶" symbol displayed when selecting a menu item has the role of a cursor. You can move it using the up and down keys. In the example shown in Figure 4-4, it is displayed in front of "RS - 232".
- The "\*" symbol displayed when selecting a menu item indicates the current setting state. In the example shown in Figure 4-4, it is displayed in front of "USB".
- The "\_" symbol (underscore) displayed when setting the value indicates the setting digit. In the example shown in Figure 4-5, it is displayed under the first digit after the decimal place in the bottom row.

```

I N T E R F A C E   * U S B
                    ▶   R S - 2 3 2
  
```

Figure 4-4 Cursor display example-1

```

L I M I T           + V = + 1 6 . 1 0 0 0 V
                    ▶ - V = - 1 0 . 5 0 0 0 V
  
```

Figure 4-5 Cursor display example-2

- **Initial display**

This is displayed after starting up this product and internal check. Even when pressing the **EXIT** key at the top menu or when setting initialization is executed, this initial screen is also displayed.

A display example is shown in Figure 4-6, and the voltage settings of the positive and negative outputs are displayed.

The voltage cannot be set on this screen.

```

                    + V = + 0 0 . 0 0 0 0 V
                    - V = - 0 0 . 0 0 0 0 V
  
```

Figure 4-6 Initial display example

- **Menu**

When pressing the **MENU** key, the top menu shown in Figure 4-7 is displayed.

The menu tree is shown in Figure 4-3. By pressing the **ENTER** key, transitions to the right or lower section of the tree. By pressing the **EXIT** key, transitions to the left or upper section of the tree.

For example, press the **ENTER** key in the state shown in Figure 4-7, the menu shifts to the output voltage setting menu shown in Figure 4-8.

Also, press the **EXIT** key in the state shown in Figure 4-8, which will shift to the top menu shown in Figure 4-7.

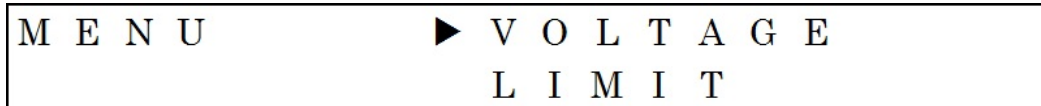

Figure 4-7 Top menu display example

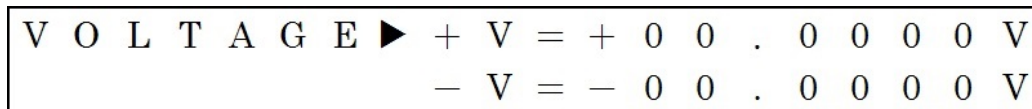

Figure 4-8 Display example of output voltage setting menu

- **Value setting operation**

Values, such as voltage, are set using the up, down, left, and right keys.

Press the left and right keys to select the digit to be modified, then press the up and down keys to change the number of the digit.

You can also continuously change the value or digit to be set by pressing and holding any of the 4 keys.

By operating the up and down keys, the value changing carries-up and down.

Even when setting both positive and negative values, pressing the up key increases the absolute value. Pressing the down key decreases the absolute value.

Ex: When setting the negative limit voltage

Figure 4-9 shows an example display when setting the negative limit voltage. From this state, Figure 4-10 to Figure 4-13 show the shift when pressing the up, down, left, and right keys, respectively.

L	I	M	I	T		+	V	=	+	1	6	.	0	0	0	0	V
					▶	-	V	=	-	1	0	.	0	<u>9</u>	4	5	V

Figure 4-9 Display example when setting the negative limit voltage

L	I	M	I	T		+	V	=	+	1	6	.	0	0	0	0	V
					▶	-	V	=	-	1	0	.	1	<u>0</u>	4	5	V

Figure 4-10 Display example when setting the negative limit voltage (when press up key)

L	I	M	I	T		+	V	=	+	1	6	.	0	0	0	0	V
					▶	-	V	=	-	1	0	.	0	<u>8</u>	4	5	V

Figure 4-11 Display example when setting the negative limit voltage (when press down key)

L	I	M	I	T		+	V	=	+	1	6	.	0	0	0	0	V
					▶	-	V	=	-	1	0	.	<u>0</u>	9	4	5	V

Figure 4-12 Display example when setting the negative limit voltage (when press left key)

L	I	M	I	T		+	V	=	+	1	6	.	0	0	0	0	V
					▶	-	V	=	-	1	0	.	0	9	<u>4</u>	5	V

Figure 4-13 Display example when setting the negative limit voltage (when press right key)



### 4.2.2 Setting the output voltage (VOLTAGE)

This is a function to set the output voltage. There are two output voltages: positive (+V) and negative (-V).

The positive and negative output voltages can be set independently or symmetrically.

→Refer to "Voltage setting mode (Vset MODE)" on page 4-20.

- **Setting the positive output voltage**

This is a function to set the positive output voltage. A display example at this function is shown in Figure 4-14.

The setting range is 0.0000 to +16.1000 V, and the setting resolution is 0.0005 V.

[Panel operation procedure]

- 1) Press the **MENU** key to enter the top menu.
- 2) Use the up and down keys to move the cursor to "VOLTAGE" and press the **ENTER** key.
- 3) Use the up key to move the cursor to "+V" and press the **ENTER** key.
- 4) Use the up, down, left, and right keys to set the positive output voltage.

\* **The setting voltage change is immediately reflected to the output voltage.**

\* The positive output voltage cannot be set to a value exceeding the positive limit voltage.

Ex: If the positive limit voltage is set to "+10.0000 V", the positive output voltage cannot be set to "+10.0100 V".

\* When press the **EXIT** key, the output voltage resets to the previous value before the change.

- 5) Press the **ENTER** key to finish the positive output voltage setting.

V	O	L	T	A	G	E	▶	+	V	=	+	1	2	.	3	4	5	0	V
								-	V	=	-	0	0	.	0	0	0	0	V

Figure 4-14 Display example when setting the positive output voltage

- **Setting the negative output voltage**

This is a function to set the negative output voltage. A display example of this function is shown in Figure 4-15.

The setting range is 0.0000 to -16.1000 V, and the setting resolution is 0.0005 V.

[Panel operation procedure]

- 1) Press the **MENU** key to enter the top menu.
- 2) Use the up and down keys to move the cursor to "VOLTAGE" and press the **ENTER** key.
- 3) Use the down key to move the cursor to "-V" and press the **ENTER** key.
- 4) Use the up, down, left, and right keys to set the negative output voltage.

**\* The setting voltage change is immediately reflected to the output voltage.**

- \* The negative output voltage cannot be set to a value exceeding the negative limit voltage.  
Ex: If the negative limit voltage is set to "-5.0000 V", the negative output voltage cannot be set to "-5.1000 V".
  - \* When the setting value is "-10.1000 V" and the cursor is at the first digit after the decimal place, pressing the up key will result in "-10.2000 V", and pressing the down key will result in "-10.0000 V".
  - \* When press the **EXIT** key, the output voltage resets to the previous value before the change.
- 5) Press the **ENTER** key to finish the negative output voltage setting.

V	O	L	T	A	G	E	+	V	=	+	1	0	.	0	0	0	0	V	
							▶	-	V	=	-	0	5	.	4	3	2	<u>0</u>	V

Figure 4-15 Display example when setting the negative output voltage

### 4.2.3 Setting the limit voltage (LIMIT)

This is a function to set the limit voltage. There are two voltages: positive (+V) and negative (-V).

By setting the limit voltage, it becomes impossible to set the output voltage to exceed it.

This is also a function to limit the setting so that overvoltage is not applied to the load due to operation mistakes.

- **Setting the positive limit voltage**

This is a function to set the positive limit voltage. A display example of this function is shown in Figure 4-16.

The setting range is +0.0005 to +16.1000 V, and the setting resolution is 0.0005 V.

[Panel operation procedure]

- 1) Press the **MENU** key to enter the top menu.
  - 2) Use the up and down keys to move the cursor to "LIMIT" and press the **ENTER** key.
  - 3) Use the up key to move the cursor to "+V" and press the **ENTER** key.
  - 4) Use the up, down, left, and right keys to set the positive limit voltage and press the **ENTER** key.
- \* When press the **EXIT** key, the limit voltage resets to the previous value.
  - \* You cannot enter the "LIMIT" menu while either output is on. Turn off both outputs before setting the limit voltage.
  - \* The positive limit voltage cannot be set to a value less than the positive output voltage.  
Ex: If the positive output voltage is set to "+12.3450 V", the positive limit voltage cannot be set to "+12.0000 V".

<pre>L I M I T      ► + V = + 1 5 . 0 0 0 0 V                   - V = - 1 6 . 1 0 0 0 V</pre>
---

Figure 4-16 Display example when setting the positive limit voltage

- **Setting the negative limit voltage**

This is a function to set the negative limit voltage. A display example of this function is shown in Figure 4-17.

The setting range is -0.0005 to -16.1000 V, and the setting resolution is 0.0005 V.

[Panel operation procedure]

- 1) Press the **MENU** key to enter the top menu.
  - 2) Use the up and down keys to move the cursor to "LIMIT" and press the **ENTER** key.
  - 3) Use the down key to move the cursor to "-V" and press the **ENTER** key.
  - 4) Use the up, down, left, and right keys to set the negative limit voltage and press the **ENTER** key.
- \* When press the **EXIT** key, the limit voltage resets to the previous value.
  - \* You cannot enter the "LIMIT" menu while either output is on. Turn off both outputs before setting the limit voltage.
  - \* The negative limit voltage cannot be set to a value less than the negative output voltage.  
Ex: If the negative output voltage is set to "-5.4320 V", the negative limit voltage cannot be set to "-5.0000 V".
  - \* When the setting value is "-10.5000 V" and the cursor is at the first digit after the decimal place, pressing the up key will result in "-10.6000 V", and pressing the down key will result in "-10.4000 V".

L I M I T	+ V = + 1 6 . 1 0 0 0 V
▶	- V = - 1 0 . 0 9 0 5 V

Figure 4-17 Display example when setting the negative limit voltage

#### 4.2.4 Setting of the remote control (INTERFACE)

This is a function to set the interface and parameters to operate with remote control. A display example is shown in Figure 4-18.

USB, RS-232, or LAN can be selected as the interface.



Figure 4-18 Display example of setting the remote control

- **Select USB interface (USB)**

The remote control interface is set to USB. A display example is shown in Figure 4-19.

[Panel operation procedure]

- 1) Press the **MENU** key to enter the top menu.
- 2) Use the up and down keys to move the cursor to "INTERFACE" and press the **ENTER** key.
- 3) Use the up and down keys to move the cursor to "USB" and press the **ENTER** key.

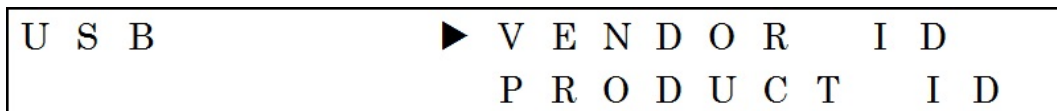

Figure 4-19 Display example after selecting USB

- ◆ **Indicate vendor ID (VENDOR ID)**

This is a function to indicate the vendor ID for USB control. A display example is shown in Figure 4-20.

[Panel operation procedure]

- 1) Press the **MENU** key to enter the top menu.
- 2) Use the up and down keys to move the cursor to "INTERFACE" and press the **ENTER** key.
- 3) Use the up and down keys to move the cursor to "USB" and press the **ENTER** key.
- 4) Use the up and down keys to move the cursor to "VENDOR ID" and press the **ENTER** key.

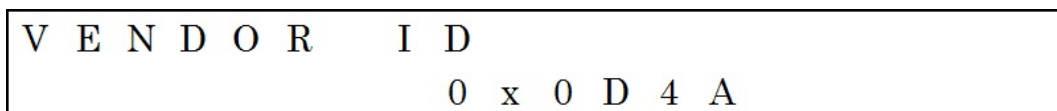

Figure 4-20 Example to indicate VENDOR ID

◆ **Indicate product ID (PRODUCT ID)**

This is a function to indicate the product ID for USB control. A display example is shown in Figure 4-21.

[Panel operation procedure]

- 1) Press the **MENU** key to enter the top menu.
- 2) Use the up and down keys to move the cursor to "INTERFACE" and press the **ENTER** key.
- 3) Use the up and down keys to move the cursor to "USB" and press the **ENTER** key.
- 4) Use the up and down keys to move the cursor to "PRODUCT ID" and press the **ENTER** key.

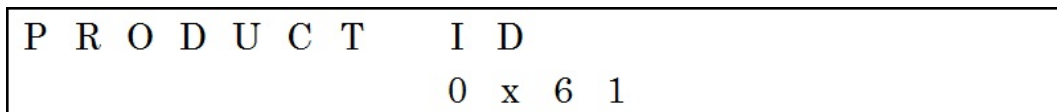

P R O D U C T I D  
0 x 6 1

Figure 4-21 Example to indicate PRODUCT ID

- **Select RS-232 interface (RS-232)**

The remote control interface is set to RS-232. A display example is shown in Figure 4-22.

[Panel operation procedure]

- 1) Press the **MENU** key to enter the top menu.
- 2) Use the up and down keys to move the cursor to "INTERFACE" and press the **ENTER** key.
- 3) Use the up and down keys to move the cursor to "RS-232" and press the **ENTER** key.

```

R S - 2 3 2      ► B A U D   R A T E
                   P A R I T Y
  
```

Figure 4-22 Display example after selecting RS-232

- ◆ **Select baud rate (BAUD RATE)**

This is a function to select the baud rate for RS-232 control. A display example is shown in Figure 4-23.

Select the baud rate from 4 choices: 9600, 19200, 38400 , or 57600 bps.

[Panel operation procedure]

- 1) Press the **MENU** key to enter the top menu.
  - 2) Use the up and down keys to move the cursor to "INTERFACE" and press the **ENTER** key.
  - 3) Use the up and down keys to move the cursor to "RS-232" and press the **ENTER** key.
  - 4) Use the up and down keys to move the cursor to "BAUD RATE" and press the **ENTER** key.
  - 5) Use the up and down keys to select the baud rate and press the **ENTER** key.
- \* When press the **EXIT** key or **MENU** key without pressing the **ENTER** key, the baud rate backs to the previous selection.

```

B A U D   R A T E   ► *   9 6 0 0
                          1 9 2 0 0
  
```

Figure 4-23 Display example when setting the baud rate

#### ◆ Select parity (PARITY)

This is a function to select the parity for RS-232 control. A display example is shown in Figure 4-24.

Select the parity from 3 choices: NONE, ODD, or EVEN.

[Panel operation procedure]

- 1) Press the **MENU** key to enter the top menu.
  - 2) Use the up and down keys to move the cursor to "INTERFACE" and press the **ENTER** key.
  - 3) Use the up and down keys to move the cursor to "RS-232" and press the **ENTER** key.
  - 4) Use the up and down keys to move the cursor to "PARITY" and press the **ENTER** key.
  - 5) Use the up and down keys to select the parity and press the **ENTER** key.
- \* When press the **EXIT** key or **MENU** key without pressing the **ENTER** key, the parity backs to the previous selection.

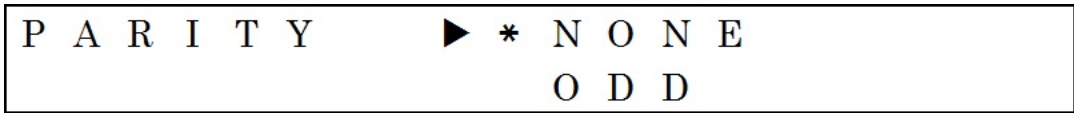

```

P A R I T Y      ► * N O N E
                  O D D
  
```

Figure 4-24 Display example when setting the parity

#### ◆ Select handshake (HANDSHAKE)

This is a function to select the handshake for RS-232 control. A display example is shown in Figure 4-25.

Select the handshake from 3 choices: NONE, SOFTWARE, or HARDWARE.

[Panel operation procedure]

- 1) Press the **MENU** key to enter the top menu.
  - 2) Use the up and down keys to move the cursor to "INTERFACE" and press the **ENTER** key.
  - 3) Use the up and down keys to move the cursor to "RS-232" and press the **ENTER** key.
  - 4) Use the up and down keys to move the cursor to "HANDSHAKE" and press the **ENTER** key.
  - 5) Use the up and down keys to select the handshake and press the **ENTER** key.
- \* When press the **EXIT** key or **MENU** key without pressing the **ENTER** key, the handshake backs to the previous selection.



```

H A N D S H A K E  ► * N O N E
                    S O F T W A R E
  
```

Figure 4-25 Display example when setting the handshake



◆ **Select terminator (TERMINATOR)**

This is a function to select the terminator for RS-232 control. A display example is shown in Figure 4-26.

Select the terminator from 3 choices: CR, LF, or CR LF.

[Panel operation procedure]

- 1) Press the **MENU** key to enter the top menu.
  - 2) Use the up and down keys to move the cursor to "INTERFACE" and press the **ENTER** key.
  - 3) Use the up and down keys to move the cursor to "RS-232" and press the **ENTER** key.
  - 4) Use the up and down keys to move the cursor to "TERMINATOR" and press the **ENTER** key.
  - 5) Use the up and down keys to select the terminator and press the **ENTER** key.
- \* When press the **EXIT** key or **MENU** key without pressing the **ENTER** key, the terminator backs to the previous selection.

T E R M I N A T O R   ▶   C R
* L F

Figure 4-26 Display example when setting the terminator

- **Select LAN interface (LAN)**

The remote control interface is set to LAN. A display example is shown in Figure 4-27.

[Panel operation procedure]

- 1) Press the **MENU** key to enter the top menu.
  - 2) Use the up and down keys to move the cursor to "INTERFACE" and press the **ENTER** key.
  - 3) Use the up and down keys to move the cursor to "LAN" and press the **ENTER** key.
- \* After selecting the LAN interface, this product does not accept any operations for about 10 seconds to update settings. At this time, the LCD shows the message in Figure 4-28.

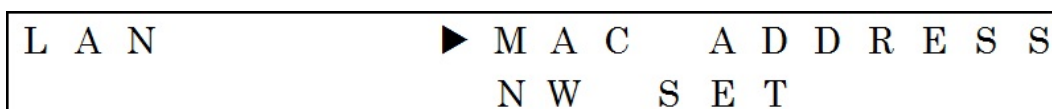

```

LAN           ►  M A C   A D D R E S S
                N W   S E T
  
```

Figure 4-27 Display example after selecting LAN

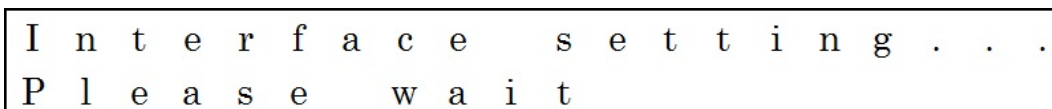

```

I n t e r f a c e   s e t t i n g . . .
P l e a s e   w a i t
  
```

Figure 4-28 Display example when updating settings

- ◆ **Indicate MAC address (MAC ADDRESS)**

This is a function to indicate the MAC address for LAN control. A display example is shown in Figure 4-29.

[Panel operation procedure]

- 1) Press the **MENU** key to enter the top menu.
- 2) Use the up and down keys to move the cursor to "INTERFACE" and press the **ENTER** key.
- 3) Use the up and down keys to move the cursor to "LAN" and press the **ENTER** key.
- 4) Use the up and down keys to move the cursor to "MAC ADDRESS" and press the **ENTER** key.

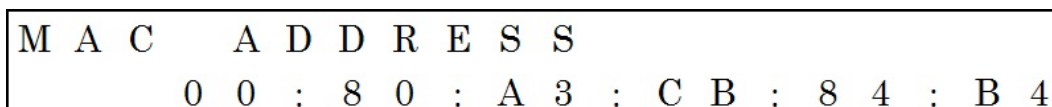

```

M A C   A D D R E S S
      0 0 : 8 0 : A 3 : C B : 8 4 : B 4
  
```

Figure 4-29 Example to indicate the MAC address

◆ **Setting the network parameters (NW SET)**

This is a function to set three types of network parameters: IP address, subnet mask, and default gateway for LAN control. Display examples are shown in Figure 4-30 to Figure 4-32.

[Panel operation procedure]

- 1) Press the **MENU** key to enter the top menu.
  - 2) Use the up and down keys to move the cursor to "INTERFACE" and press the **ENTER** key.
  - 3) Use the up and down keys to move the cursor to "LAN" and press the **ENTER** key.
  - 4) Use the up and down keys to move the cursor to "NW SET" and press the **ENTER** key. It then changes to the "IP ADDRESS" menu.
  - 5) Use the up, down, left, and right keys to set "IP ADDRESS" and press the **ENTER** key. It then changes to the "SUBNET MASK" menu.
  - 6) Use the up, down, left, and right keys to set "SUBNET MASK" and press the **ENTER** key. It then changes to the "DEF GATEWAY" menu.
  - 7) Use the up, down, left, and right keys to set "DEF GATEWAY" and press the **ENTER** key. The three setting are then confirmed.
- \* After setting "NW SET", this product does not accept any operations for about 10 seconds to update settings. At this time, the LCD shows the message in Figure 4-33.

```

N W   S E T   I P   A D D R E S S
      1 9 2 . 1 6 8 .       2 . 2 5 2
  
```

Figure 4-30 Display example when setting the IP address

```

N W   S E T   S U B N E T   M A S K
      2 5 5 . 2 5 5 . 2 5 5 .   0
  
```

Figure 4-31 Display example when setting subnet mask

```

N W   S E T   D E F   G A T E W A Y
      1 9 2 . 1 6 8 .       2 .   1
  
```

Figure 4-32 Display example when setting default gateway

```

I n t e r f a c e   s e t t i n g . . .
P l e a s e   w a i t
  
```

Figure 4-33 Display example when updating settings

◆ **Indicate port number (PORT NUMBER)**

This is a function to indicate the port number for LAN control. A display example is shown in Figure 4-34.

[Panel operation procedure]

- 1) Press the **MENU** key to enter the top menu.
- 2) Use the up and down keys to move the cursor to "INTERFACE" and press the **ENTER** key.
- 3) Use the up and down keys to move the cursor to "LAN" and press the **ENTER** key.
- 4) Use the up and down keys to move the cursor to "PORT NUMBER" and press the **ENTER** key.

P O R T      N U M B E R
1 0 0 0 1

Figure 4-34 Example to indicate the port number

### 4.2.5 Others (UTILITY)

This includes menu items not included in the above menus. Display examples are shown in Figure 4-35 and Figure 4-36.

There are 9 items: Vout MODE, Vset Mode, POW ON Vout, LCD LIGHT, LCD CONTRAST, INITIALIZE, INFORMATION, FW VERSION, and CAL DATE.

```

U T I L I T Y ▶ V o u t   M O D E
                V s e t   M O D E
  
```

Figure 4-35 Display example of UTILITY menu-1

```

U T I L I T Y   F W   V E R S I O N
                ▶ C A L   D A T E
  
```

Figure 4-36 Display example of UTILITY menu-2

#### • Output mode (Vout MODE)

The states of the positive and negative outputs can be switched independently or coupled. They can be set in the "Vout MODE" menu. A display example is shown in Figure 4-37.

- INDEP : Independent control. Pressing the "+OUTPUT ON/OFF" key turns on and off the positive voltage output, and pressing the "-OUTPUT ON/OFF" key turns on and off the negative voltage output.
- COUPLED : Coupled control. By pressing the "+OUTPUT ON/OFF" key or "-OUTPUT ON/OFF" key, both the positive and negative outputs turn on and off.

[Panel operation procedure]

- 1) Press the **MENU** key to enter the top menu.
  - 2) Use the up and down keys to move the cursor to "UTILITY" and press the **ENTER** key.
  - 3) Use the up and down keys to move the cursor to "Vout MODE" and press the **ENTER** key.
  - 4) Use the up and down keys to move the cursor to select and press the **ENTER** key.
- \* You cannot enter the "Vout MODE" menu while either output is on. Turn off both outputs before setting "Vout MODE".

```

V o u t   M O D E   ▶ * I N D E P
                    C O U P L E D
  
```

Figure 4-37 Display example when setting "Vout MODE"

• **Voltage setting mode (Vset MODE)**

The positive and negative output voltages can be set independently or symmetrically. They can be set in the "Vset MODE" menu. A display example is shown in Figure 4-38.

- INDEP: Independent control. The positive and negative output voltages can be set independently.
- TRACKING: Tracking control. The positive and negative output voltages can be set symmetrically so that the absolute values of them match.

[Panel operation procedure]

- 1) Press the **MENU** key to enter the top menu.
  - 2) Use the up and down keys to move the cursor to "UTILITY" and press the **ENTER** key.
  - 3) Use the up and down keys to move the cursor to "Vset MODE" and press the **ENTER** key.
  - 4) Use the up and down keys to move the cursor to select and press the **ENTER** key.
- \* You cannot enter the "Vset MODE" menu while either output is on. Turn off both outputs before setting "Vset MODE".
  - \* When the absolute value of the positive and negative output voltages do not match, changing the voltage setting mode from independent to tracking sets the output voltage to match the lower one.

Ex: When the positive output voltage is +10.0000 V and the negative one is -12.0000 V, changing the voltage setting mode from independent to tracking sets the negative output voltage to -10.0000 V.



Figure 4-38 Display example when setting "Vset MODE"

- **The output state at startup (POW ON Vout)**

The state of outputs, on or off at startup, is selectable. It can be set in the "POW ON Vout" menu. A display example is shown in Figure 4-39.

- ON: Both positive and negative outputs are on at startup.
- OFF: Both positive and negative outputs are off at startup.
- LAST STATE: At startup, both positive and negative outputs are the same as the last operation state.

[Panel operation procedure]

- 1) Press the **MENU** key to enter the top menu.
- 2) Use the up and down keys to move the cursor to "UTILITY" and press the **ENTER** key.
- 3) Use the up and down keys to move the cursor to "POW ON Vout" and press the **ENTER** key.
- 4) Use the up and down keys to move the cursor to select and press the **ENTER** key.

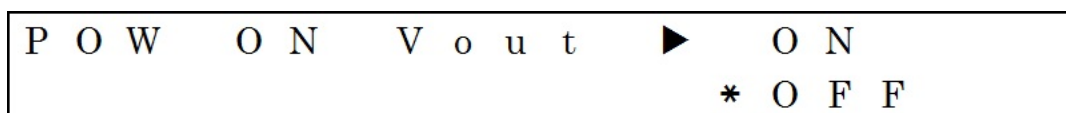

Figure 4-39 Display example when setting "POW ON Vout"

- **Brightness of the LCD (LCD LIGHT)**

The brightness of the LCD is adjustable in 4 levels. This can be set in the "LCD LIGHT" menu. A display example is shown in Figure 4-40.

When set to LEVEL 0, the backlight is turned off. The brightness increases as the level number increases, and the maximum brightness is LEVEL 3.

[Panel operation procedure]

- 1) Press the **MENU** key to enter the top menu.
- 2) Use the up and down keys to move the cursor to "UTILITY" and press the **ENTER** key.
- 3) Use the up and down keys to move the cursor to "LCD LIGHT" and press the **ENTER** key.
- 4) Use the up and down keys to select the level number and press the **ENTER** key.

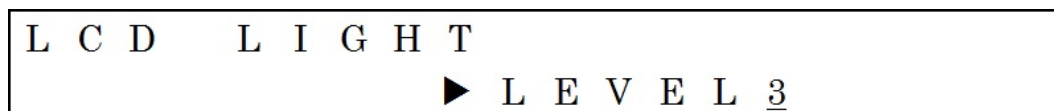

Figure 4-40 Display example when setting "LCD LIGHT"

- **Contrast of the LCD (LCD CONTRAST)**

The contrast of the LCD is adjustable in 8 levels. This can be set in the "LCD CONTRAST" menu. A display example is shown in Figure 4-41.

LEVEL 0 is the lowest contrast. The contrast increases as the level number increases, and the highest contrast is LEVEL 7.

[Panel operation procedure]

- 1) Press the **MENU** key to enter the top menu.
- 2) Use the up and down keys to move the cursor to "UTILITY" and press the **ENTER** key.
- 3) Use the up and down keys to move the cursor to "LCD CONTRAST" and press the **ENTER** key.
- 4) Use the up and down keys to select the level number and press the **ENTER** key.

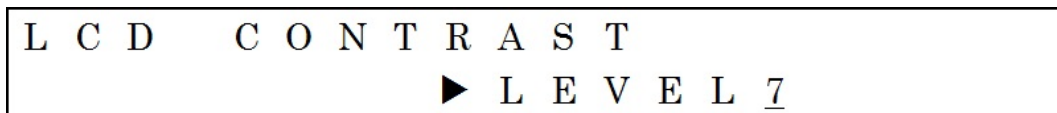

Figure 4-41 Display example when setting "LCD CONTRAST"



- **Setting initialization (INITIALIZE)**

This is a function to initialize the settings. However, the settings of remote control and LCD are not initialized. A display example is shown in Figure 4-42.

[Panel operation procedure]

- 1) Press the **MENU** key to enter the top menu.
- 2) Use the up and down keys to move the cursor to "UTILITY" and press the **ENTER** key.
- 3) Use the up and down keys to move the cursor to "INITIALIZE" and press the **ENTER** key.
- 4) Use the up and down keys to move the cursor to "EXECUTE" and press the **ENTER** key.

After setting initialization is complete, the LCD returns to the initial display.

- \* When press the **ENTER** key with the cursor on "CANCEL", initialization does not execute.
- \* When press the **EXIT** key, initialization does not execute.
- \* You cannot enter the "INITIALIZE" menu while either output is on. Turn off both outputs before initialization.
- \* The settings after initialization are as listed in Table 4-1.

Table 4-1 Settings after initialization

The state of the positive voltage output	OFF	
The state of the negative voltage output	OFF	
Positive output voltage	+00.0000 V	
Negative output voltage	-00.0000 V	
Positive limit voltage	+16.1000 V	
Negative limit voltage	-16.1000 V	
Setting of remote control	Interface	Not initialized
	Baud rate	Not initialized
	Parity	Not initialized
	Handshake	Not initialized
	Terminator	Not initialized
	IP address	Not initialized
	Subnet mask	Not initialized
	Default gateway	Not initialized
Output mode (VoutMODE)	INDEP (Independent control)	
Voltage setting mode (Vset mode)	INDEP (Independent control)	
The output state at startup (POW ON Vout)	OFF (Always off at startup)	
Brightness of LCD (LCD LIGHT)	Not initialized	
Contrast of LCD (LCD CONTRAST)	Not initialized	

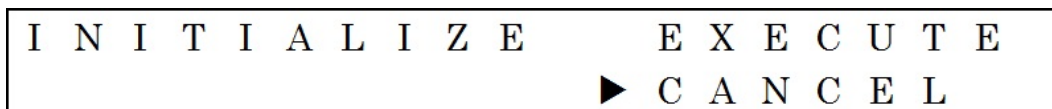

Figure 4-42 Display example of "INITIALIZE" menu

- **Indicate the product information (INFORMATION)**

This is a function to indicate the model name of this product and serial number. Display examples are shown in Figure 4-43 to Figure 4-44.

Use the up and down keys to change the display to model or serial number.

[Panel operation procedure]

- 1) Press the **MENU** key to enter the top menu.
- 2) Use the up and down keys to move the cursor to "UTILITY" and press the **ENTER** key.
- 3) Use the up and down keys to move the cursor to "INFORMATION" and press the **ENTER** key.
- 4) Use the up and down keys to change the display to model or serial number.

I N F O R M A T I O N L P 6 0 1 6 - 0 1
--

Figure 4-43 Example to indicate the product information (model)

I N F O R M A T I O N S / N    1 2 3 4 5 6 7
---

Figure 4-44 Example to indicate the product information (serial number)

- **Indicate the firmware version (FW VERSION)**

This is a function to indicate the firmware version. A display example is shown in Figure 4-45.

[Panel operation procedure]

- 1) Press the **MENU** key to enter the top menu.
- 2) Use the up and down keys to move the cursor to "UTILITY" and press the **ENTER** key.
- 3) Use the up and down keys to move the cursor to "FW VERSION" and press the **ENTER** key.

F W    V E R S I O N 1 . 0 0
---------------------------------

Figure 4-45 Example to indicate the firmware version

- **Indicate the last calibration date (CAL DATE)**

This is a function to indicate the last date that this product was calibrated by NF Corporation or our service engineers. A display example is shown in Figure 4-46.

[Panel operation procedure]

- 1) Press the **MENU** key to enter the top menu.
- 2) Use the up and down keys to move the cursor to "UTILITY" and press the **ENTER** key.
- 3) Use the up and down keys to move the cursor to "CAL DATE" and press the **ENTER** key.

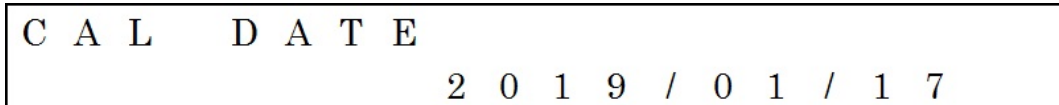

```
C A L   D A T E
                2 0 1 9 / 0 1 / 1 7
```

Figure 4-46 Example to indicate the last calibration date

## 4.3 Operations no included in the menu tree

### 4.3.1 Switching the output on and off

The positive and negative outputs can be switched independently or coupled.

→Refer to "Output mode (Vout MODE)" on page 4-19.

- **Switching the positive output on and off**

Pressing the **+OUTPUT ON/OFF** key switches the positive output on and off.

- **Switching the negative output on and off**

Pressing the **-OUTPUT ON/OFF** key switches the negative output on and off.

#### [Precautions in use]

The relays switching the outputs on and off are the life span parts. Again and again switching the outputs on and off may damage the relays. In particular, under conditions of use that switching the outputs on and off frequently, failure may occur even within the warranty period of this product. So, please avoid such usage.

### 4.3.2 Switching from remote control state to local operation state

When operating with remote control, this product enters the state in which local operation (panel operation) is not accepted, and "REMOTE" is displayed on the LCD.

When press the **LOCAL** key, "REMOTE" on the LCD disappears and this product enters the state in which local operation (panel operation) can be accepted.

### 4.3.3 Initialization of the LCD setting

This is the operation to initialize the brightness and contrast settings (LCD LIGHT, LCD CONTRAST) of the LCD. Keep pressing the **MENU** key for more than 3 seconds to execute. Table 4-2 lists the settings after initialization.

Table 4-2 LCD settings after initialization

LCD LIGHT (LCD brightness)	LEVEL 3 (brightest)
LCD CONTRAST	LEVEL 7 (highest)

## 4.4 Connection notes

### 4.4.1 Output connection

Although this product can supply low noise DC voltage, its performance may not be optimal depending on the connection method. Follow the precautions below and make the appropriate connections.

- 1) Connect using a coaxial cable.

When connecting with a non-shielded cable, external noise may affect this product.

- 2) Connect using a cable of about 2 m or less in length.

When using an unnecessarily long cable, even the coaxial cable may be affected by external noise. Load regulation may deteriorate depending on the wiring resistance of the cable. Connect using an appropriate length.

- 3) The contact shape and dimensions of the BNC connector are regulated by IEC or JIS standards. Use connectors conforming to these standards. If using connectors that are non-compliant, the output terminal will become damaged, deteriorating performance.

### 4.4.2 Current-monitor connection

The current-monitor terminal of this product should be connected to a high input impedance circuit such as DC voltage measurement input of a digital multimeter. Since the output impedance of the current-monitor terminal is 1 k $\Omega$ , the error increases when connected to a circuit with low input impedance.

Check the input impedance of the circuit to connect before connecting.

Also, the output common and current-monitor common are connected. When the current-monitor terminal is connected to a grounded terminal such as an oscilloscope, its common will also be grounded.



## 5. Remote control

5.1	Preparations before remote control.....	5-2
5.1.1	Select the remote control interface .....	5-2
5.1.2	USB interface.....	5-2
5.1.3	RS-232 interface.....	5-4
5.1.4	LAN interface .....	5-6
5.1.5	Precautions for remote control.....	5-8
5.2	Changing of remote control and local operation states .....	5-8
5.3	Commands .....	5-9
5.3.1	Parameter Formats .....	5-9
5.3.2	Symbols .....	5-9
5.3.3	Input format.....	5-9
5.4	Command explanations .....	5-10
5.4.1	Switch output on/off .....	5-10
5.4.2	Output voltage (Voltage) .....	5-11
5.4.3	Limit voltage (LIMIT) .....	5-11
5.4.4	Output mode (Vout MODE) .....	5-12
5.4.5	Voltage setting mode (Vset MODE) .....	5-12
5.4.6	The output state at startup (POW ON Vout).....	5-13
5.4.7	Brightness of the LCD (LCD LIGHT) .....	5-14
5.4.8	Contrast of the LCD (LCD CONTRAST).....	5-14
5.4.9	Query the abnormal state.....	5-15
5.4.10	Query the error queue.....	5-15
5.4.11	Clear the error queue.....	5-15
5.4.12	Query the product information.....	5-16
5.4.13	Reset (Initialize).....	5-16
5.4.14	Switching from remote control state to local operation state .....	5-16

## 5.1 Preparations before remote control

This product can be remotely controlled via the USB, RS-232, and LAN interfaces.

With remote control, you can control this product and monitor the protection status the same as with panel operation.

The connectors of each interface are on the rear panel.

### 5.1.1 Select the remote control interface

Select USB, RS-232, or LAN as the remote control interface. The interfaces cannot be used at the same time.

### 5.1.2 USB interface

- **Controller**

When using the USB interface, use a controller (e.g., PC) equipped with a USB port.

Install the USB CDC driver on the controller.

USB CDC: Universal Serial Bus Communication Device Class

The USB CDC driver dedicated to this product can be downloaded from our website.

<http://www.nfcorp.co.jp/english/index.html>

- **Preparation of this product**

Select "USB" at the interface setting of this product.

For the operation procedure, refer to "Select USB interface (USB)" on page 4-11.

- **Connection**

The USB interface connector of this product is USB 2.0 Type B. Use a cable that is suitable for the USB 2.0 Type B connector to connect this product to the controller.

Also, connect using cables of the maximum length (5 m) or less specified in the standard.



- **Parameters**

Set so that the parameters match between this product and the controller. In case of mismatch, problems or errors may occur.

- ◆ **Message terminator**

Both program and response message terminators are "LF". This cannot be changed.

- ◆ **Vendor ID**

The vendor ID of this product is "0x0D4A". This can also be confirmed with the function indicating vendor ID.

For the operation procedure, refer to "Indicate vendor ID (VENDOR ID)" on page 4-11.

- ◆ **Product ID**

The product ID of this product is "0x61". This can also be confirmed with the function indicating product ID.

For the operation procedure, refer to "Indicate product ID (PRODUCT ID)" on page 4-12.

- ◆ **Serial number**

The serial number is unique to the product. This can be confirmed with the function indicating product information or the identification label on the rear panel.

For the operation procedure, refer to "Indicate the product information (INFORMATION)" on page 4-24.

- **Identification of USB devices**

Connect this product to the USB port of a PC using a USB cable.

When using a PC with a USB CDC driver installed, it is recognized automatically.

This product is identified by the vendor ID, product ID, and serial number. This information can be confirmed from the procedure above.

Use this information when manually identifying this product, i.e., when this product can not be recognized automatically.

- **Precautions**

- When connecting via a USB hub, this product may not operate properly.
- When connecting with a cable exceeding the maximum length (5 m) specified in the standard, this product may not operate properly.
- To avoid malfunction caused by radiated electromagnetic field noise, be sure to use a shielded cable.

### 5.1.3 RS-232 interface

- **Controller**

When using the RS-232 interface, use a controller (e.g., PC) equipped with an RS-232 port.

- **Preparation of this product**

Select "RS-232" at the interface setting of this product.

For the operation procedure, refer to "Select RS-232 interface (RS-232)" on page 4-13.

Also, set the following parameters.

- Baud rate: for this operation procedure, refer to "Select baud rate (BAUD RATE)" on page 4-13.
- Parity: for this operation procedure, refer to "Select parity (PARITY)" on page 4-14.
- Handshake: for this operation procedure, refer to "Select handshake (HANDSHAKE)" on page 4-14.
- Terminator: for this operation procedure, refer to "Select terminator (TERMINATOR)" on page 4-15.

- **Connection**

The RS-232 interface connector of this product is a male D-SUB connector (9 pins). The pin assignment of the connector is shown in Figure 5-1, and the pin assignment is listed in Table 5-1.

Use a crossover cable to connect this product with the controller.

Also, connect using cables with the maximum length (15 m) or less specified in the standard.

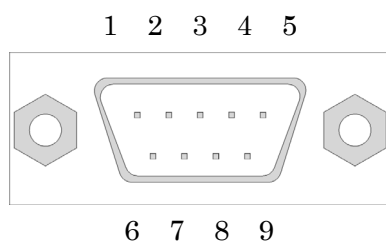

Figure 5-1 Pin assignment of RS-232 connector

Table 5-1 RS-232 pin assignment

PIN NUMBER	FUNCTION
1	No Connection (Not used, open)
2	RxD
3	TxD
4	No Connection (Not used, open)
5	GND
6	No Connection (Not used, open)
7	RTS
8	CTS
9	No Connection (Not used, open)

- **Parameters**

Set so that the parameters match between this product and the controller. In case of mismatch, problems or errors may occur.

- ◆ **Baud rate**

Select from 4 types: 9600, 19200, 38400, or 57600 bps.

- ◆ **Data length**

Data length is 8 bits. This cannot be changed.

- ◆ **Stop bit length**

Both program and response stop bit lengths are 1 bit. This cannot be changed.

- ◆ **Parity**

Select from 3 types: NONE, ODD, or EVEN.

- ◆ **Handshake**

Select from 3 types: NONE, SOFTWARE, or HARDWARE.

- ◆ **Message terminator**

Select from 3 types: CR, LF, or CR LF.

- **Precautions**

- Multiple devices cannot be connected simultaneously to one RS-232 port.
- When connecting with a cable exceeding the maximum length (15 m) specified in the standard, this product may not operate properly.
- To avoid malfunction caused by radiated electromagnetic field noise, be sure to use a shielded cable.
- With the handshake set to “NONE”, the communication may not be executed correctly. Use handshake as much as possible.
- With the handshake set to “HARDWARE”, use the cable with the RTS and CTS signals linked.

### 5.1.4 LAN interface

This interface only supports TCP/IP.

It does not correspond to the IP address automatically assigned by DHCP. When connecting to the network, contact the administrator and set the IP address, subnet mask, and default gateway.

- **Controller**

When using the LAN interface, use a controller (e.g., PC) equipped with a LAN port.

- **Preparation of this product**

Select "LAN" at the interface setting of this product.

For the operation procedure, refer to "Select LAN interface (LAN)" on page 4-16.

Also, set the parameters listed below.

For this operation procedure, refer to "Setting the network parameters (NW SET)" on page 4-17.

- IP address
- Subnet mask
- Default gateway

- **Connection**

When connecting to the network, use a straight cable. When connecting to a PC directly, use a crossover cable.

However, when using a hub or connecting a PC that can automatically recognize straight and crossover, you can use either.

Use cables compliant with CAT 5e or later. When using a cable of a previous standard, communication speed may be slow or electromagnetic interference to peripheral devices may occur.

- **Parameters**

Set so that the parameters match between this product and the controller. In case of mismatch, problems or errors may occur.

- ◆ **MAC address**

The MAC address is unique to each product and cannot be changed. It can also be confirmed with the function indicating the MAC address.

For the operation procedure, refer to "Indicate MAC address (MAC ADDRESS)" on page 4-16.

### ◆ IP address

An IP address is a numerical label assigned to each device connected to a computer network that uses the Internet Protocol for communication. It can be set.

For the operation procedure, refer to “Setting the network parameters (NW SET)” on page 4-17.

### ◆ Subnet mask

Subnet mask separates the network address and host address of the IP address. It can be set.

For the operation procedure, refer to “Setting the network parameters (NW SET)” on page 4-17.

### ◆ Default gateway

Default gateway is the address of the gateway (router) used implicitly when accessing an external network. It can be set.

For the operation procedure, refer to “Setting the network parameters (NW SET)” on page 4-17.

### ◆ Port number

The port number of this product is “10001” and cannot be changed. It can be confirmed with the function indicating port number.

For the operation procedure, refer to “Indicate port number (PORT NUMBER)” on page 4-18.

### ◆ Message terminator

Both program and response message terminators are "LF". This cannot be changed.

### ● Precautions

- Use cables compliant with CAT 5e or later.
- To avoid malfunction caused by radiated electromagnetic field noise, be sure to use a shielded cable.
- Avoid unnecessarily stretching the connecting cable. As the length becomes longer, it is easier to accept external noise.
- This product does not correspond to the IP address automatically assigned by DHCP. When connecting to the network, contact the administrator and set the IP address, subnet mask, and default gateway. Misconfiguration may interfere with communication on the connected network.

### 5.1.5 Precautions for remote control

- **Input buffer**

- This product stores the received commands in the input buffer first then interprets and executes them.
- The input buffer size is 512 bytes. Do not send program messages continuously as this size is exceeded. Program messages exceeding the input buffer size are ignored.
- When receiving a command that is non-compliant with the specifications, an error occurs and an error message is displayed. For error messages, refer to "6.1 Error messages".
- When sending program messages continuously, in order not to exceed the input buffer size, please leave a transmission interval of the program messages that is longer than 50 msec.

- **Output buffer**

The output buffer size is 512 bytes.

- **Message terminator**

When sending a command from the controller, be sure to attach a message terminator to the end of the message string. It does not work properly without a message terminator.

- **Error queue**

Errors related to remote control are held in the error queue which can hold up to 20 errors. When it exceeds 20, old errors are deleted in order.

For errors related to remote control, refer to Table 6-4 in Section 6.1.

## 5.2 Changing of remote control and local operation states

This product has two states: remote control (remote state) and local operation.

In the local operation state, all panel operations are possible.

In the remote control state, however, this product cannot accept any panel operations except the LOCAL key. Also, as shown in Figure 5-2, "REMOTE" is displayed on the LCD.

R	E	M	O	T	E	+	V	=	+	1	6	.	1	0	0	0	V
						-	V	=	-	1	6	.	1	0	0	0	V

Figure 5-2 Display example during remote control

---

## 5.3 Commands

The remote control command of this product consists of a header of 3 to 5 characters and 0 to 2 parameters. One space is necessary between a header and first parameter

### 5.3.1 Parameter Formats

Unless otherwise the parameter format is not defined on each section, integer format (NR1) can be used for setting selection, and integer format (NR1) and real number formats (NR2, NR3) can be used for numerical setting.

- **NR1: Integer format**

- This is a format not including a decimal point and the position of the decimal point is interpreted as the end of the last digit.
- "+" or "-" can be used (when positive, "+" can be omitted).

Ex: +1234, -98, 67

- **NR2: Real number format (fixed-point number format)**

- This is a format including a decimal point, and its decimal point position is indicated with "." (period).
- When the digit before the decimal point is omitted, the integer part is interpreted as "0" (zero).
- "+" or "-" can be used (when positive, "+" can be omitted).

Ex: +98.76, -12.0, 4.3

- **NR3: Real number format (Exponential format)**

- This consists of a mantissa with a decimal point and an exponent indicating  $10^n$ . The position of the decimal point is "." (period), and the boundary between the mantissa and exponent is indicated by "E".
- When the digit before the decimal point is omitted, the integer part is interpreted as "0" (zero).
- "+" or "-" can be used (when positive, "+" can be omitted).
- A sign can be attached to each mantissa and exponent.

Ex: +0.123E4, -56.0E-7, 8.9E-1

### 5.3.2 Symbols

- The vertical bar (|) means selecting one from several words.
- "xx", "yy", "zz", and "aa" mean parameter 1, 2, 3 and 4 respectively.

### 5.3.3 Input format

Commands can be uppercase or lowercase. Also, uppercase and lowercase may be mixed. However, half-width characters are only valid; double-byte characters cannot be used.

## 5.4 Command explanations

The header list of commands for this product is shown in Table 5-2.

Table 5-2 The header list of commands

Function	Set/Query	Header	Page
Switch output on/off	Both	OUT	5-10
Output voltage (Voltage)	Both	VLT	5-11
Limit voltage (LIMIT)	Both	LMV	5-11
Output mode (Vout MODE)	Both	OMD	5-12
Voltage setting mode (Vset MODE)	Both	VMD	5-12
The output state at startup (POW ON Vout)	Both	POS	5-13
Brightness of the LCD (LCD LIGHT)	Both	LBD	5-14
Contrast of the LCD (LCD CONTRAST)	Both	LCD	5-14
Query the abnormal state	Query only	PST?	5-15
Query the error queue	Query only	ERQ?	5-15
Clear the error queue	Set only	EQC	5-15
Query the product information	Query only	*IDN?	5-16
Reset (Initialize)	Set only	*RST	5-16
Switching from remote control state to local operation state	Set only	GTL	5-16

### 5.4.1 Switch output on/off

- **Set**

Command:           OUT xx,yy  
 Parameter 1:       1|2 (NR1)  
                       1: Positive output, 2: Negative output  
 Parameter 2:       0|1 (NR1)  
                       0: OFF, 1: ON  
 Command Ex:       OUT 2,1  
                       Switch negative output to on.

- **Query**

Command:           OUT? xx  
 Parameter 1:       1|2 (NR1)  
                       1: Positive output, 2: Negative output  
 Return value:      yy  
 Parameter 2:       0|1 (NR1)  
                       0: OFF, 1: ON  
 Command Ex:       OUT? 1  
                       Query whether positive output is on or off.  
 Return value Ex:   1  
                       The positive output is on.



### 5.4.2 Output voltage (Voltage)

- **Set**

Command: VLT xx,yy  
Parameter 1: 1|2 (NR1)  
1: Positive output, 2: Negative output  
Parameter 2: Voltage (NR2, NR3)  
Setting range: Positive: 0.0000 to +16.1000, Negative: 0.0000 to -16.1000  
Setting resolution: 0.0005  
Command Ex: VLT 1,+1.2345  
Set the positive output voltage to +1.2345 V.  
Precaution: It cannot be set to exceed the limit voltage.

- **Query**

Command: VLT? xx  
Parameter 1: 1|2 (NR1)  
1: Positive output, 2: Negative output  
Return value: yy  
Parameter 2: Voltage (NR2, NR3)  
Command Ex: VLT? 2  
Query negative output voltage.  
Return value Ex: -9.8765  
The negative output voltage is -9.8765 V.

### 5.4.3 Limit voltage (LIMIT)

- **Set**

Command: LMV xx,yy  
Parameter 1: 1|2 (NR1)  
1: Positive output, 2: Negative output  
Parameter 2: Limit voltage (NR2, NR3)  
Setting range: Positive: +0.0005 to +16.1000, Negative: -0.0005 to -16.1000  
Setting resolution: 0.0005  
Command Ex: LMV 1,+1.2345  
Set the positive limit voltage to +1.2345 V.  
Precaution: It cannot be set to be less than the output voltage.

- **Query**

Command: LMV? xx  
 Parameter 1: 1|2 (NR1)  
 1: Positive output, 2: Negative output  
 Return value: yy  
 Parameter 2: Limit voltage (NR2, NR3)  
 Command Ex: LMV? 2  
 Query negative limit voltage.  
 Return value Ex: -9.8765  
 The negative limit voltage is -9.8765 V.

#### 5.4.4 Output mode (Vout MODE)

- **Set**

Command: OMD xx  
 Parameter 1: 0|1 (NR1)  
 0: Independently control (INDEP), 1: Coupled control (COUPLED)  
 Command Ex: OMD 1  
 Set the output mode to coupled control (COUPLED).

- **Query**

Command: OMD?  
 Parameter: No need  
 Return value: xx  
 Parameter 1: 0|1 (NR1)  
 0: Independently control (INDEP), 1: Coupled control (COUPLED)  
 Command Ex: OMD?  
 Query output mode.  
 Return value Ex: 0  
 Output mode is independently controlled (INDEP).

#### 5.4.5 Voltage setting mode (Vset MODE)

- **Set**

Command: VMD xx  
 Parameter 1: 0|1 (NR1)  
 0: Independently control (INDEP), 1: Tracking control (TRACKING)  
 Command Ex: VMD 1  
 Set the voltage setting mode to tracking control (TRACKING).

- **Query**

Command: VMD?  
 Parameter: No need  
 Return value: xx  
 Parameter 1: 0|1 (NR1)  
 0: Independently control (INDEP), 1: Tracking control (TRACKING)  
 Command Ex: VMD?  
 Query voltage setting mode.  
 Return value Ex: 0  
 Voltage setting mode is independently controlled (INDEP).

#### 5.4.6 The output state at startup (POW ON Vout)

- **Set**

Command: POS xx  
 Parameter 1: 0|1|2 (NR1)  
 0: Both positive and negative outputs are off at startup (OFF).  
 1: Both positive and negative outputs are on at startup (ON).  
 2: At startup, both positive and negative outputs are the same as last operation (LAST STATE).  
 Command Ex: POS 1  
 Set the output state at startup to “Both positive and negative outputs are on at startup (ON).”.

- **Query**

Command: POS?  
 Parameter: No need  
 Return value: xx  
 Parameter 1: 0|1|2 (NR1)  
 0: Both positive and negative outputs are off at startup (OFF).  
 1: Both positive and negative outputs are on at startup (ON).  
 2: At startup, both positive and negative outputs are the same as last operation (LAST STATE).  
 Command Ex: POS?  
 Query output state at startup.  
 Return value Ex: 0  
 The output state at startup is “Both positive and negative outputs are off at startup (OFF).”.

---

### 5.4.7 Brightness of the LCD (LCD LIGHT)

- **Set**

Command: LBD xx  
Parameter 1: 0 to 3 (NR1)  
0: The backlight of the LCD is off.  
1 to 3: The brightness increases as the value increases.  
Command Ex: LBD 3  
Set the brightness of the LCD to maximum.

- **Query**

Command: LBD?  
Parameter: No need  
Return value: xx  
Parameter 1: 0 to 3 (NR1)  
0: The backlight of the LCD is off.  
1 to 3: The brightness increases as the value increases.  
Command Ex: LBD?  
Query the brightness of the LCD.  
Return value Ex: 0  
The backlight of the LCD is off.

### 5.4.8 Contrast of the LCD (LCD CONTRAST)

- **Set**

Command: LCD xx  
Parameter 1: 0 to 7 (NR1)  
The contrast increases as the value increases.  
Command Ex: LCD 7  
Set the contrast of the LCD to maximum.

- **Query**

Command: LCD?  
Parameter: No need  
Return value: xx  
Parameter 1: 0 to 7 (NR1)  
0: The backlight of the LCD is off.  
The contrast increases as the value increases.  
Command Ex: LCD?  
Query the contrast of the LCD.  
Return value Ex: 0  
The contrast of the LCD is minimum.

**5.4.9 Query the abnormal state**

Command:	PST?
Parameter:	No need
Return value:	xx
Parameter 1:	0 to 63 (NR1) Each state is weighted as follows. This value of parameter 1 is sum of them. 1: The positive output current exceeds the rating and overcurrent protection is working (E102) 2: The negative output current exceeds the rating and overcurrent protection is working (E103) 4: Overheat protection is working (E104) 8: Calibration data are broken (E303) 16: Setting data are broken (E304, E305) 32: Hardware error (E901, E902, E903)
Command Ex:	PST? Query the abnormal condition.
Return value Ex:	3 Both positive and negative output currents exceed the rating and protection is working.

**5.4.10 Query the error queue**

Command:	ERQ?
Parameter:	No need
Return value:	xx,yy (String)
Parameter 1:	Error number (Refer to “6.1 Error messages”)
Parameter 2:	Error message (“6.1 Error messages”) *When the error queue is empty, the return is the value shown in the following "Return value Ex2".
Command Ex:	ERQ? Reads the oldest error held in the error queue. Refer to “Error queue” on page 5-8.
Return value Ex 1:	ERROR501,Command error
Return value Ex 2:	ERROR0,No error

**5.4.11 Clear the error queue**

Command:	EQC
Parameter:	No need
Return value:	Nothing
Explanation:	Clear entire error queue.

#### 5.4.12 Query the product information

Command:	*IDN?
Parameter:	No need
Return value:	xx,yy,zz,aa (String)
Parameter 1:	Vendor name
Parameter 2:	Model name
Parameter 3:	Serial number
Parameter 4:	Firmware version
Command Ex:	*IDN? Query the product information.
Return value Ex:	NF Corporation,LP6016-01,1234567,1.00

#### 5.4.13 Reset (Initialize)

Command:	*RST
Parameter:	No need
Return value:	Nothing
Explanation:	It is the same function as “INITIALIZE” of the panel operation. For details, refer to “Setting initialization (INITIALIZE)” on page 4-23.
Precaution:	It cannot be executed while either output is on.

#### 5.4.14 Switching from remote control state to local operation state

Command:	GTL
Parameter:	No need
Return value:	Nothing
Explanation:	It is the same function as pressing the <b>LOCAL</b> key. For details, refer to Sections 4.3.2 and 5.2.

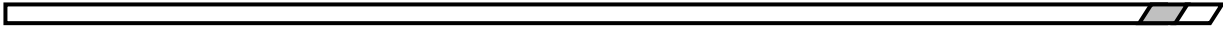





## 6. Troubleshooting

6.1	Error messages.....	6-2
6.2	Quick diagnosis .....	6-6

## 6.1 Error messages

This product displays error messages on the LCD when there are errors in the internal check at startup, panel operation, or remote control operation.

A display example of an error message is shown in Figure 6-1.

E 1 0 5	A C l i n e e r r o r
	C a n ' t o p e r a t e

Figure 6-1 Display example of error message

Error messages that are not listed in this instruction manual may be displayed due to firmware update etc. If there are other manuals provided, refer to them as well.

Table 6-1 General error list

No.	Message	Explanation	Solution
E101	±OCP (Displayed at lower left of LCD)	Indicates that both positive and negative output currents exceed the rating.	Check and reduce the loads that connected to both positive and negative outputs.
E102	+OCP (Displayed at lower left of LCD)	Indicates that the positive output current exceeds the rating.	Check and reduce the load that connected to the positive output.
E103	-OCP (Displayed at lower left of LCD)	Indicates that the negative output current exceeds the rating.	Check and reduce the load that connected to the negative output.
E104	OHP (Displayed at lower left of LCD)	Indicates that the internal temperature exceeds a certain value and overheat protection is in operation. When this error occurs, the outputs are turned off and cannot be turned on until the problem is solved.	It is highly probable that the ambient temperature or output current rating has been exceeded. Check and improve the conditions of use; otherwise, carry out forced cooling using, e.g., fans.
E105	AC line error Can't operate	Indicates that the power supply voltage is lower. When this error occurs, this product does not work properly.	Make the settings of the power supply voltage selector on the rear panel and the power supply voltage match. Then reboot the product.

## 6.1 Error messages

Table 6-2 Error list of panel operation

No.	Message	Explanation	Solution
E201	Setting error +Vout over LIMIT	This error occurs when trying to set the positive output voltage to exceed its limit voltage.	Check the limit voltage of the positive output.
E202	Setting error -Vout over LIMIT	This error occurs when trying to set the negative output voltage to exceed its limit voltage.	Check the limit voltage of the negative output.
E203	Setting error LIMIT under +Vout	This error occurs when trying to set the limit voltage to less than the voltage setting of the positive output.	Check the positive output voltage.
E204	Setting error LIMIT under -Vout	This error occurs when trying to set the limit voltage to less than the voltage setting of the negative output.	Check the negative output voltage.
E205	Invalid input Turn off output	This error occurs when trying to set "Vout MODE" while output is on.	Turn off both positive and negative outputs before setting it.
E206	Invalid input Turn off output	This error occurs when trying to set "Vset MODE" while output is on.	Turn off both positive and negative outputs before setting it.
E207	Invalid input Turn off output	This error occurs when trying to set the limit voltage while output is on.	Turn off both positive and negative outputs before setting it.
E208	Invalid input Turn off output	This error occurs when trying to initialize while output is on.	Turn off both positive and negative outputs before setting it.
E209	Invalid input Exit this menu	This error occurs when trying to turn the output on in "Vout MODE" or "Vset MODE" or setting the limit voltage.	Operate after leaving these menus.
E210	Invalid input Clear error	This error occurs when trying to turn on output while E104, E105, or E303 is present.	Address each error and reboot this product.
E211	Setting error Out of Range	This error occurs when trying to set the output voltage or limit voltage outside the range.	Check the setting ranges referred to in Sections 8.2 and 8.3.

Table 6-3 Error list of internal memory

No.	Message	Explanation	Solution
E303	Memory error Can't operate	This error occurs when important internal data are broken.	The product is out of order. Contact NF Corporation or an authorized agent.
E304	Memory error Initialized	This error occurs when the setting data related to the remote control are broken. When this error occurs, settings related to the remote control are initialized.	The product can be used normally after resetting.
E305	Memory error Initialized	This error occurs when setting data, except for the remote control, are broken. When this error occurs, settings, except to the remote control, are initialized.	The product can be used normally after resetting.

Table 6-4 Error list of remote control

No.	Message	Explanation	Solution
E501	Command error	This error occurs when receiving an undefined command.	Check whether the command is correct.
E502	Syntax error	This error occurs in the following cases such as when "?" is attached to the set only command, when "?" is not attached to the query only command, and when there is an excess or lack of "space".	Check whether the command is correct.
E503	Parameter error	This error occurs when the parameters of the command are out of range or the parameters include incorrect characters.	Check whether the parameters are correct.

\*Refer to "5.3 Commands" for the commands and parameters.

Table 6-5 Serious error list

No.	Message	Explanation	Solution
E901	Unknown error Can't operate	This error occurs when an unexpected problem with the hardware occurred.	The product is out of order. Contact NF Corporation or an authorized agent.
E902	Internal error Can't operate	This error occurs when a fatal problem with the positive output occurred.	The product is out of order. Contact NF Corporation or an authorized agent.
E903	Internal error Can't operate	This error occurs when a fatal problem with the negative output occurred.	The product is out of order. Contact NF Corporation or an authorized agent.
E904	Software error Can't operate	This error occurs when a fatal problem with the software occurred.	The product is out of order. Contact NF Corporation or an authorized agent.

## 6.2 Quick diagnosis

When operation is believed to be abnormal, check Table 6-6 first. If there is no related description or the problem cannot be solved by executing a "Solution", contact NF Corporation or an authorized agent.

Table 6-6 Troubleshooting

Problem	Possible cause	Solution
Cannot power on	The power cord is not correctly inserted.	Insert the power cord securely.
	The settings of the power supply voltage selector and power supply voltage do not match.	Make the setting of the voltage selector on the rear panel and the power supply voltage match.
	Fuse is expired.	Replace the fuse. (Refer to "2.3 Grounding and Power Connections".)
The output voltage is abnormal	Overloaded ("OCP" is indicated on the LCD)	Maximum output current is 100 mA. Check the output load.
The output of the current monitor is abnormal	Current-monitor terminal is connected to the small impedances.	Check the impedance connected to this product. When this is small, the output voltage is divided and it looks small.
Cannot operate with the panel	This product is set to the remote control state (remote mode).	Press the "LOCAL" key on the front panel to switch to the panel operation state (local mode).
Cannot operate with the remote control	Remote control setting and selected interface do not match controller.	Check the setting related to the remote control.
	The connection cable is not inserted correctly.	Connect the cable securely.
	The connection cable is non-compliant with the standards. Ex: The cable is too long	Use a cable that is compliant with the standard. (Refer to "5.1 Preparations before remote control".)
The output noise is large	This product is connected to the controller via a hub, repeater, or etc.	Connect this product and controller one on one.
	The output is connected to the load by using an unshielded cable.	Unshielded cables are easily affected by external noise. Use a shielded cable such as a coaxial cable.
	The connection cable is too long. (more than 2 m)	Even shielded cables, such as coaxial ones, are affected by external noise when too long. Use cables that are short as possible.
	When this product is exposed to disturbance such as a strong electromagnetic radiation.	Remove the disturbance.

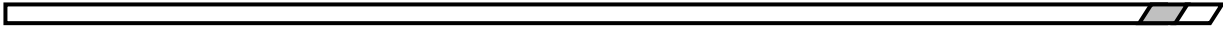





## 7. Maintenance

7.1	Introduction .....	7-2
7.2	Daily maintenance .....	7-2
7.3	Storage, repacking, and transportation .....	7-2
7.4	Check the firmware version number .....	7-3
7.5	Performance testing .....	7-4
7.5.1	Introduction .....	7-4
7.5.2	Testing output voltage setting accuracy .....	7-5
7.5.3	Testing line regulation .....	7-6
7.5.4	Testing load regulation .....	7-7
7.5.5	Testing current-monitor accuracy .....	7-8
7.6	Calibration .....	7-9

## 7.1 Introduction

The following maintenance items are essential for using this product under the best conditions.

- Quick operation check: Check if this product operates properly.
- Performance testing: Check if the specifications are satisfied.
- Calibration, adjustment: If this product is not in compliance with the specifications, NF Corporation will make the necessary adjustment or calibration to restore performance.
- Malfunction, repairs: When performance cannot be restored by calibration or adjustment, NF Corporation will identify the cause and location of the damage and execute repairs.

This instruction manual describes the procedures of quick operation check and performance testing.

For calibration, adjustment, or repair, contact NF Corporation or an authorized agent.

---

**⚠ WARNING**

---

To prevent exposure to high voltages, never open the case of this product.

Even when inspection inside this product is needed, only service engineers certified by NF Corporation should touch the inside.

---

## 7.2 Daily maintenance

If the surface of the panel or other parts becomes dirty, wipe it with a soft cloth. To remove persistent contamination, wipe with a soft cloth soaked with neutral detergent and wrung out. Do not use any organic solvents such as thinners or benzene, or any chemical cleaning cloth, as they may cause the surface finish to deteriorate, tarnish, or come off.

## 7.3 Storage, repacking, and transportation

This product should be stored in a location that satisfies the storage conditions (refer to “2.2.2 Installation environment”).

When repacking this product for transportation, use a box that is sufficiently strong and large enough to provide a surplus of space. To fully protect this product, fill the box with packing material that can withstand its weight.

Make sure that the package is handled with care to avoid strong shocks during transport.

## 7.4 Check the firmware version number

Due to product upgrades, the firmware version of each product may differ even if they are of the same model. Operation of the product may differ due to difference in versions. If any anomaly is found, inform NF Corporation of the problem along with the version number.

The latest firmware information is published on our website.

You can check the firmware version number using the startup display (Figure 7-1) or the following procedure.

[Procedure checking firmware version number]

- 1) Press the **MENU** key to enter the top menu.
- 2) Use the up and down keys to move the cursor to "UTILITY" and press the **ENTER** key.
- 3) Use the up and down keys to move the cursor to "FW VERSION" and press the **ENTER** key.
- 4) Then the LCD displays the message shown in Figure 7-2. The firmware version number is displayed in the bottom row.

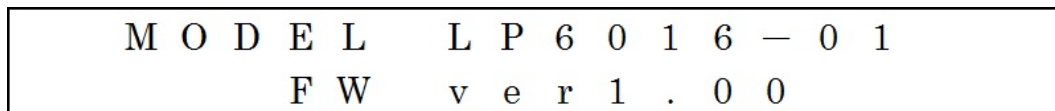

```
MODEL LP6016-01
FW ver 1.00
```

Figure 7-1 Display example at startup

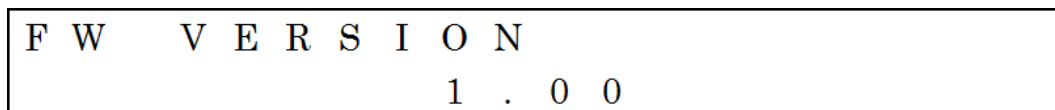

```
FW VERSION
1.00
```

Figure 7-2 Display example of firmware version

## 7.5 Performance testing

### 7.5.1 Introduction

Performance tests are conducted to check that there is no abnormality of this product.

Testing is done for acceptance inspection, periodic inspections, and whenever it is necessary to check performance, such as after repair.

This section describes a test that can be conducted with general measurement instruments.

Calibration is available at charge and can be requested from NF Corporation or an authorized agent.

If the performance test indicates that this product does not comply with the specifications, re-adjustment or repair is required. In such a case, contact NF Corporation or an authorized agent.

- **Test conditions**

This product should be tested under the following conditions.

- Temperature      23 °C ± 5 °C
- Humidity          20 to 70 %RH, no condensation
- Warm-up          60 minutes or more
- Other              Before the test, initialize the settings.  
Setting Initialization is to execute "INITIALIZE" for panel operation or  
"\*RST" for remote control operation.

- **Measurement instruments**

The required measurement instruments are listed in Table 7-1.

Table 7-1 Measurement instrument list

Name	Required specifications	Ex:
Digital multimeter-1	Input impedance: 1 MΩ or more. DC voltage measurement accuracy: ± 0.005 % or better for 0 to 10 V	Keithley 2000 NF DM2561A
Digital multimeter-2	DC current measurement accuracy: ± 0.1 % or better for 0 to 100 mA	Keithley 2000 NF DM2561A
AC power supply	28-VA output possible with AC 90 to 110 V, 50 or 60 Hz.	NF EC750SA NF EC1000SA
DC electronic load or load resistor	100-mA output possible with 10 V. 100 Ω, 3 W or more (The lower the temperature coefficient, the better)	NF DL3000 series -

### 7.5.2 Testing output voltage setting accuracy

The following is how to test for positive output voltage as well as negative output voltage.

- Connect the two devices as shown in Figure 7-3.
- Set the positive output voltage to + 10.0000 V and turn on the output.
- Measure the DC voltage with the digital multimeter-1.
- Refer to Table 7-2 and check that specification " $\pm (| 0.03 \% \text{ of setting } | + 250 \mu\text{V})$ " is satisfied.
- Also test by setting the output voltage to 0.0000 V.

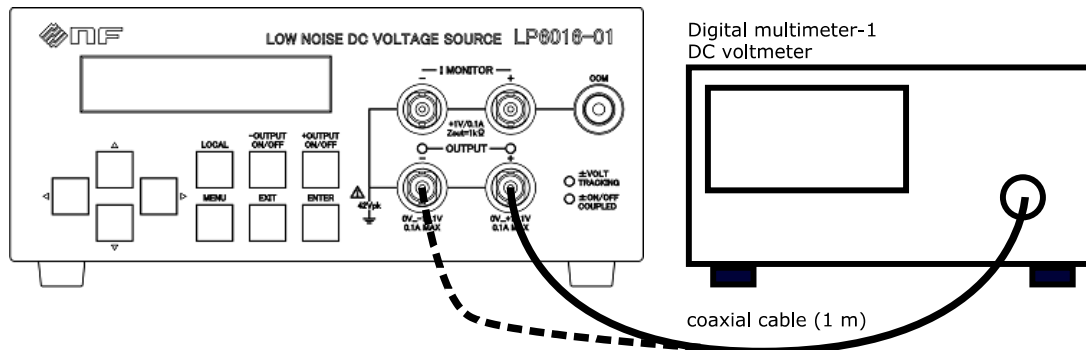

Figure 7-3 Diagram of connection when testing voltage setting accuracy  
(For measurement on the negative side, make the connection shown with the broken line.)

Table 7-2 Judgement for voltage setting accuracy

Output polarity	Setting voltage	Passing range	Measured voltage
Positive	0.0000 V	- 0.25 to + 0.25 mV	. mV
	+ 10.0000 V	+ 9.99675 to + 10.00325 V	. V
Negative	0.0000 V	- 0.25 to + 0.25 mV	. mV
	- 10.0000 V	- 9.99675 to - 10.00325 V	. V

**7.5.3 Testing line regulation**

The following is how to test for positive output voltage as well as negative output voltage.

- Connect the devices as shown in Figure 7-4.
- Set the voltage of the AC power supply to AC 100 V.
  - \* The frequency may be either 50 or 60 Hz.
- Set the positive output voltage of LP6016-01 to + 10.0000 V and turn on the output.
- Measure the DC voltage with the digital multimeter-1, which is defined as “V<sub>100</sub>[V]”.
- Measure the DC voltage also with AC 90 and 110 V, which is defined as “V<sub>90</sub>[V]” and “V<sub>110</sub>[V]”, respectively.
- Line regulation is calculated by “V<sub>90</sub> - V<sub>100</sub>” or “V<sub>110</sub> - V<sub>100</sub>”.
- Refer to Table 7-3 and check that specification "± 0.1 mV" is satisfied.

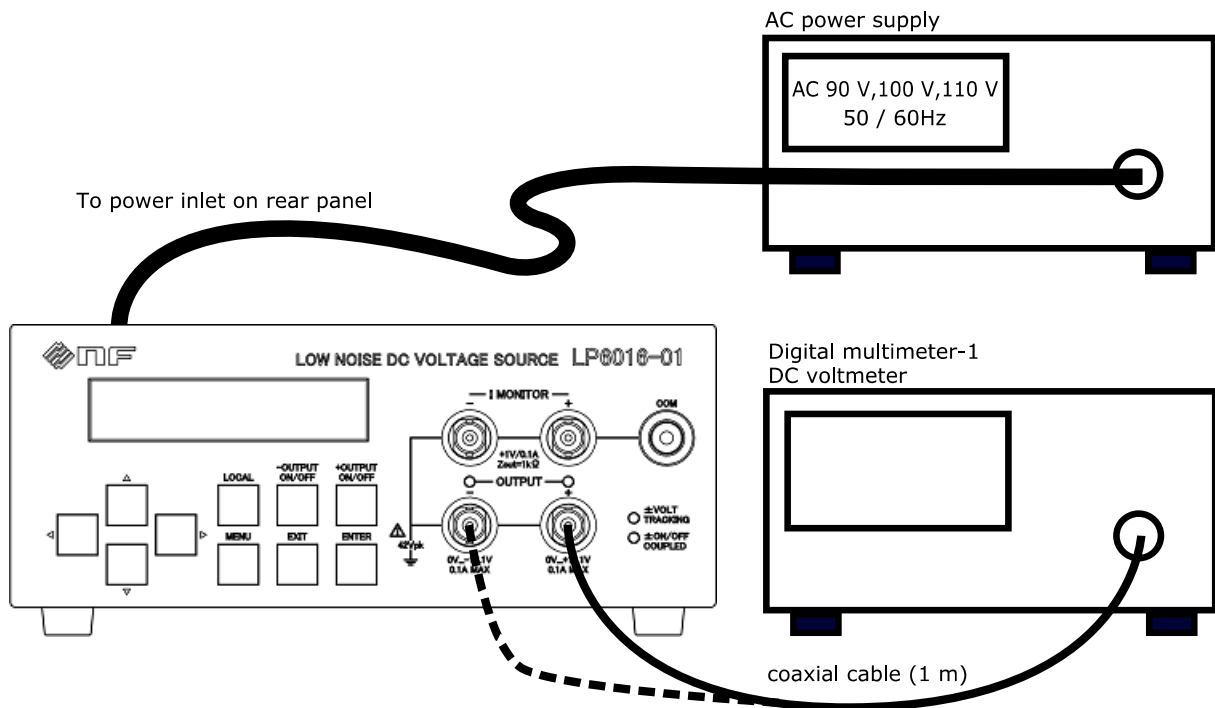

Figure 7-4 Diagram of connection when testing line regulation

(For measurement on the negative side, make the connection shown with the broken line.)

Table 7-3 Judgement for line regulation

Output polarity	Item	Passing range	Measured voltage
Positive	V <sub>90</sub>	- 0.1 to + 0.1 mV	. V
	V <sub>100</sub>		. V
	V <sub>110</sub>		. V
	V <sub>90</sub> - V <sub>100</sub>		. mV
	V <sub>110</sub> - V <sub>100</sub>		. mV
Negative	V <sub>90</sub>	- 0.1 to + 0.1 mV	. V
	V <sub>100</sub>		. V
	V <sub>110</sub>		. V
	V <sub>90</sub> - V <sub>100</sub>		. mV
	V <sub>110</sub> - V <sub>100</sub>		. mV

7.5.4 Testing load regulation

The following is how to test for positive output voltage as well as negative output voltage.

- Connect the devices as shown in Figure 7-5.  
Set the DC electronic load to 100 mA or use a load resistor of 100 Ω.
- Set the positive output voltage of LP6016-01 to + 10.0000 V and turn on the output.
- Measure the DC voltage with the digital multimeter-1.  
The measured voltage when the load is connected is defined as  $V_{100}[V]$ .  
The measured voltage when the load is not connected is defined as  $V_0[V]$ .
- Load regulation is calculated by " $V_{100} - V_0$ ".
- Refer to Table 7-4 and check that specification " $\pm 5 \text{ mV}$ " is satisfied.

[Caution] The load resistor (100 Ω) produces high temperature.

Be careful not to place it on melty vinyl or paper that may burn. Do not touch the load resistor directly.

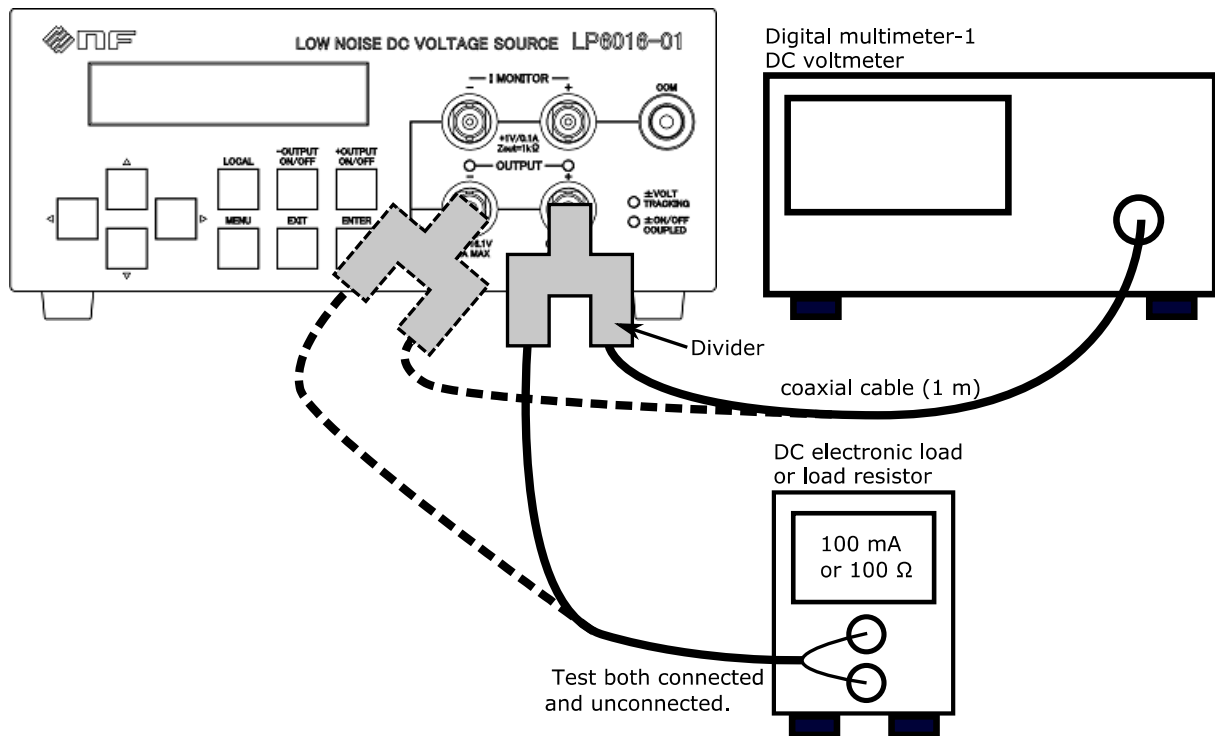

Figure 7-5 Diagram of connection when testing load regulation

(For measurement on the negative side, make the connection shown with the broken line.)

Table 7-4 Judgement for load regulation

Output polarity	Item	Passing range	Measured voltage
Positive	$V_0$	- 5 to + 5 mV	V
	$V_{100}$		V
	$V_{100} - V_0$		mV
Negative	$V_0$	- 5 to + 5 mV	V
	$V_{100}$		V
	$V_{100} - V_0$		mV

### 7.5.5 Testing current-monitor accuracy

The following shows how to test for current-monitor accuracy.

- Connect the devices as shown in Figure 7-6.
- Set the positive output voltage of LP6016-01 to + 10.0000 V and turn on the output.
- Set the negative output voltage of LP6016-01 to - 10.0000 V and turn on the output.
- Measure the DC voltage with the digital multimeter-1, which is defined as “ $V_M[V]$ ”.
- Measure the DC current with the digital multimeter-2, which is defined as “ $I_o[A]$ ”.
- Current-monitor accuracy is calculated by  $\{I_o - (0.1 \times V_M)\} / I_o \times 100$ .
- Refer to Table 7-5 and check that specification “ $\pm (1 \% + 1.5 \text{ mA})$ ” is satisfied.

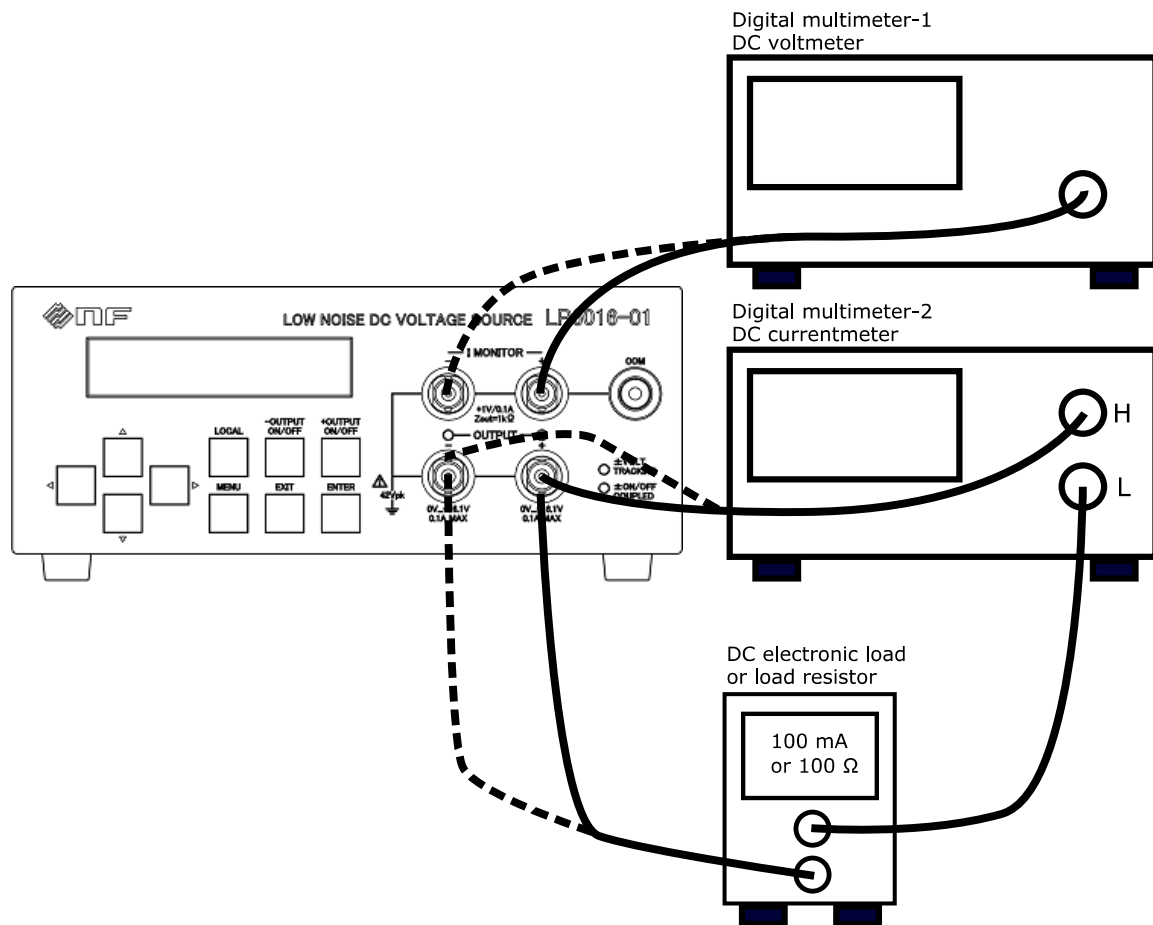

Figure 7-6 Diagram of connection when testing current-monitor accuracy

(For measurement on the negative side, make the connection shown with the broken line.)

Table 7-5 Judgement for current-monitor accuracy

Output polarity	Item	Passing range	Measured voltage
Positive	$V_M$	-	V
	$I_o$		A
	$\{I_o - (0.1 \times V_M)\} / I_o \times 100$		- 2.5 to + 2.5%
Negative	$V_M$	-	V
	$I_o$		A
	$\{I_o - (0.1 \times V_M)\} / I_o \times 100$		- 2.5 to + 2.5%



## **7.6 Calibration**

Although this product depends on the use environment or frequency of use, conduct "7.5 Performance testing" at least once a year. Also, when using it for important measurements and tests, it is recommended to test before use.

Calibration is available at charge and can be requested from NF Corporation or an authorized agent.

If the performance test indicates that this product does not satisfy the specifications, re-adjustment or repair is required. In such a case, contact NF Corporation or an authorized agent.



## 8. Specifications

8.1	Regulator type .....	8-2
8.2	Output characteristics .....	8-2
8.3	Limit function of setting output voltage .....	8-3
8.4	Current monitor .....	8-3
8.5	Power supply .....	8-3
8.6	Interface for remote control .....	8-4
8.7	Others .....	8-4
8.7.1	Output common terminal (COM) .....	8-4
8.7.2	Enclosure terminal (CHASSIS) .....	8-4
8.7.3	Insulation resistance .....	8-4
8.7.4	Withstanding voltage.....	8-4
8.7.5	Protection function .....	8-5
8.7.6	Setting of power on .....	8-5
8.7.7	Environmental conditions .....	8-5
8.7.8	Dimensions and weight .....	8-5
8.7.9	Standards .....	8-5
8.8	External dimensions.....	8-6

## 8.1 Regulator type

Series regulator

## 8.2 Output characteristics

Output terminal	BNC receptacle connector	Positive and negative
Voltage range	0.000 0 to + 16.100 0 V	+OUTPUT
	0.000 0 to - 16.100 0 V	-OUTPUT
Setting resolution	500 $\mu$ V	
Setting method	By manual operation or remote PC control. Positive and negative output voltages can be tracked depending on the setting. (When tracked, LED of "± VOLT TRACKING" lights up.)	
Setting accuracy	$\pm$ ( $  0.03$ % of setting $ $ + 250 $\mu$ V)	23 °C $\pm$ 5 °C, no load. The monotonicity is guaranteed (when temperature and output current are constant).
Temperature coefficient	$\pm$ 10 ppm/°C (typical)	
Maximum current	$\pm$ 100 mA	$ $ Output Voltage $  \geq 1$ V 0 to 50 °C
	$\pm$ 100 mA	$ $ Output Voltage $  < 1$ V 0 to 40 °C
	$\pm$ 90 mA	$ $ Output Voltage $  < 1$ V 40 to 50 °C
Settling time	100 ms	Both rise and fall, no load
Line regulation	Within $\pm 0.1$ mV	For supply voltage $\pm 10$ %
Load regulation	Within $\pm 5$ mV	Load 0 mA reference for 0 to 100 mA
Ripple noise	10 $\mu$ V <sub>rms</sub> or lower (typical)	Bandwidth 10 Hz to 20 MHz Output current 0 to $\pm 100$ mA
Time drift	$\pm 40$ ppm (typical)	8 hours after 60-minute warm-up Output voltage $\pm 16.1000$ V
Output ON/OFF	By manual operation or remote PC control. Positive and negative outputs ON/OFF can be coupled, that is switched at the same time, depending on the setting. (When coupled, LED of "± ON / OFF COUPLED" lights up.)	
Output common	The output common (COM) and enclosure (chassis) are isolated.	

### 8.3 Limit function of setting output voltage

Function	This is a function to prevent erroneous excessive voltage from being applied. The output voltage exceeding the limit voltage cannot be set.	
Setting range	+ 0.000 5 to + 16.100 0 V	+OUTPUT
	- 0.000 5 to - 16.100 0 V	-OUTPUT
Setting resolution	500 $\mu$ V	

### 8.4 Current monitor

Output signal *8-1	Voltage outputs with conversion gain of 1 V/100 mA.	
Output terminal *8-2	BNC receptacle connector	Positive and negative
Output impedance	1 k $\Omega$	
Accuracy	$\pm$ (1 % + 1.5 mA)	23 °C $\pm$ 5 °C
	$\pm$ (1 % + 2 mA)	0 to 50 °C
	In current equivalent, no load	

\*8-1: Built in low pass filter of about 300 Hz.

\*8-2: The common of the voltage outputs and current monitors are the same (COM).

### 8.5 Power supply

Voltage	AC 100/120/220/240 V $\pm$ 10 %
	However, must not exceed AC 250 V.
	Select using "VOLTAGE SELECTOR" switch on rear panel
Frequency	50 /60 Hz $\pm$ 2 Hz
Power consumption	28 VA or lower
Overvoltage category	II
Fuse	Use the rated fuses listed in Table 8-1.

Table 8-1 Fuse rating

Power supply voltage	Rated current	Rated voltage	Remark
100 V	0.4 A	250 V	Time-lag type $\phi$ 5.2 $\times$ 20 mm
120 V			
220 V	0.2 A		
240 V			

## 8.6 Interface for remote control

USB	USB2.0 full speed, device class CDC
RS-232	Connector: D-sub 9pin, male Baud rate: Select from 4 types: 9600, 19200, 38400, or 57600 bps Parity: Select from 3 types: NONE, ODD, or EVEN Handshake: Select from 3 types: NONE, SOFTWARE, or HARDWARE Program and response message terminator: Select from 3 types: CR, LF, or CR LF Data length: 8 bits Stop bit: 1 bit
LAN	10BASE-T/100BASE-TX, TCP/IP

## 8.7 Others

### 8.7.1 Output common terminal (COM)

This terminal is connected to the output common (COM) and corresponds to the banana plug of  $\phi$  4 mm. Wire of  $\phi$  2.5 mm or less can also be connected.

### 8.7.2 Enclosure terminal (CHASSIS)

This terminal is connected to the enclosure (CHASSIS) and corresponds to the banana plug of  $\phi$  4 mm. Wire of  $\phi$  2.5 mm or less can also be connected.

### 8.7.3 Insulation resistance

Between all power inputs and chassis	50 M $\Omega$ or more (with DC 500 V)
Between all power inputs and outputs	50 M $\Omega$ or more (with DC 500 V)
Between output common (COM) and chassis	10 M $\Omega$

### 8.7.4 Withstanding voltage

Between all power inputs and outputs/chassis	AC 1500 V for 1 minute
Between output common (COM) and chassis	$\pm$ 42 Vpk (DC + AC peak)

**8.7.5 Protection function**

Over current protection	Drooping characteristic (about 150 mA, self recovery type)
Over current indication	"OCP" is displayed and flashes (when output current exceeds about 100 mA)
Over heat protection	Outputs are turned off when an internal temperature exceeds the threshold
Over heat indication	"OHP" is displayed and flashes

**8.7.6 Setting of power on**

At power-on, each setting condition will be the same as that when powered off last time.

However, only the output ON/OFF state is selectable by the following setting.

Always ON/Always OFF/Last state

**8.7.7 Environmental conditions**

Altitude	2000 m or lower
Operating temperature range	0 to +50 °C
Operating humidity range	5 to 85 %RH, absolute humidity 1 to 25 g/m <sup>3</sup> , non-condensation
Storage temperature range	-10 to +60 °C
Storage humidity range	5 to 95 %RH, absolute humidity 1 to 29 g/m <sup>3</sup> , non-condensation
Cooling method	Natural convection cooling
Pollution degree	2 (indoor use)
Warm-up time	60 minutes

**8.7.8 Dimensions and weight**

Dimensions (W×H×D)	215 × 86 × 330 mm (without protrusions)
Weight	Approx. 3.5 kg (without accessories)

**8.7.9 Standards**

RoHS	Directive 2011/65/EU
EMC *8-3	EN 61326-1 EN 61000-3-2 EN 61000-3-3
Safety *8-3	EN 61010-1

\*8-3: Only models with CE marking on the rear panel

## 8.8 External dimensions

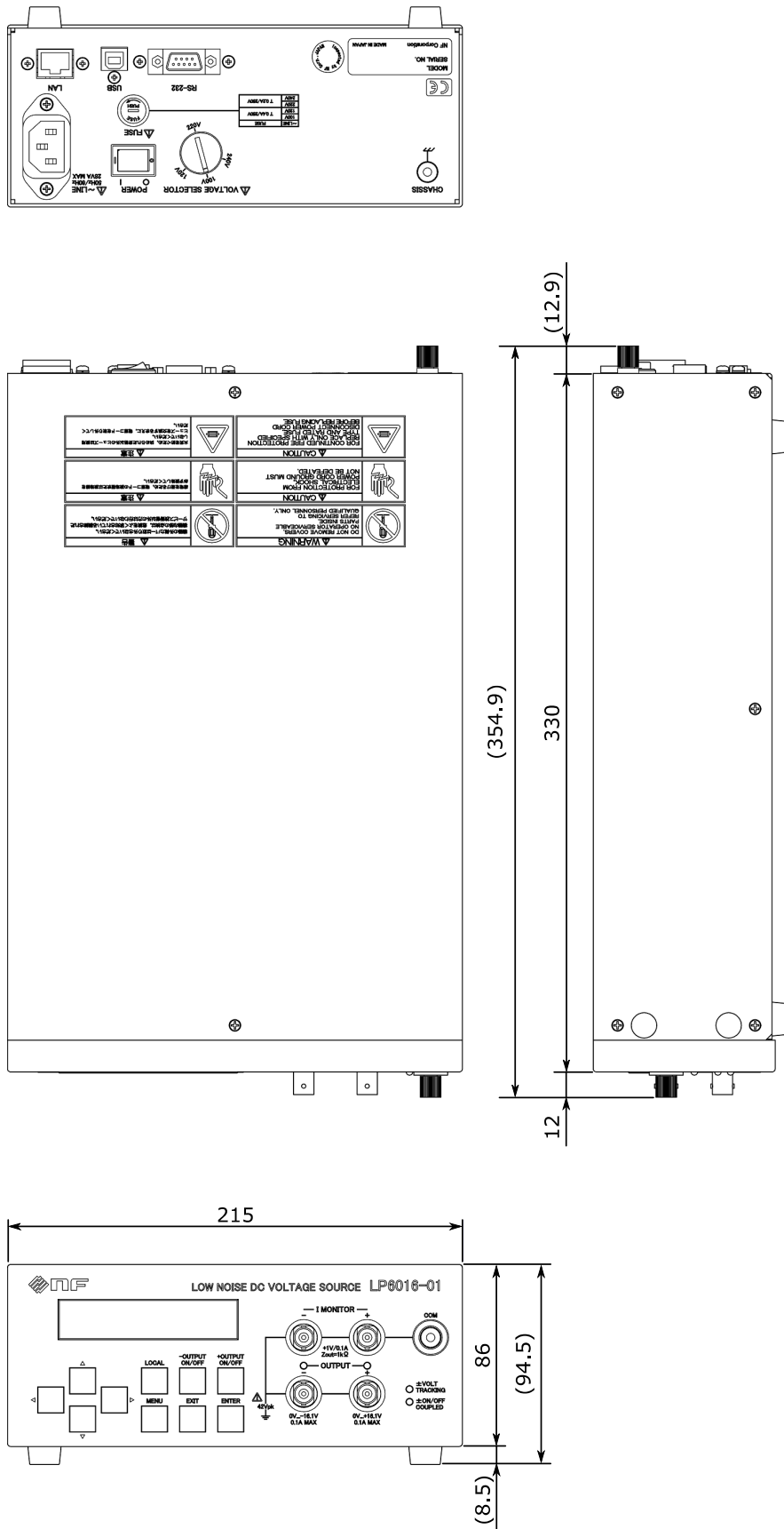
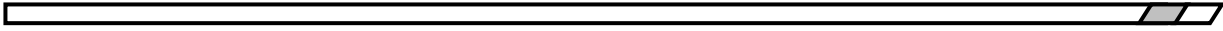

Figure 8-1 External dimensions







## 9. Typical data

9.1	Typical data.....	9-2
9.2	Output noise voltage density frequency characteristics.....	9-2
9.3	Time stability .....	9-3
9.4	Temperature coefficients .....	9-4

## 9.1 Typical data

Representative performance of this product is described for reference. For individual products, the performance may not reach this data, but we confirm that all products comply with the specifications by conducting strict shipping tests.

## 9.2 Output noise voltage density frequency characteristics

The output noise voltage density frequency characteristics are shown in Figure 9-1. It shows the characteristics of positive voltage output as a representative. Negative voltage output has the same characteristics.

Conditions: +16.1000 V, 100 mA

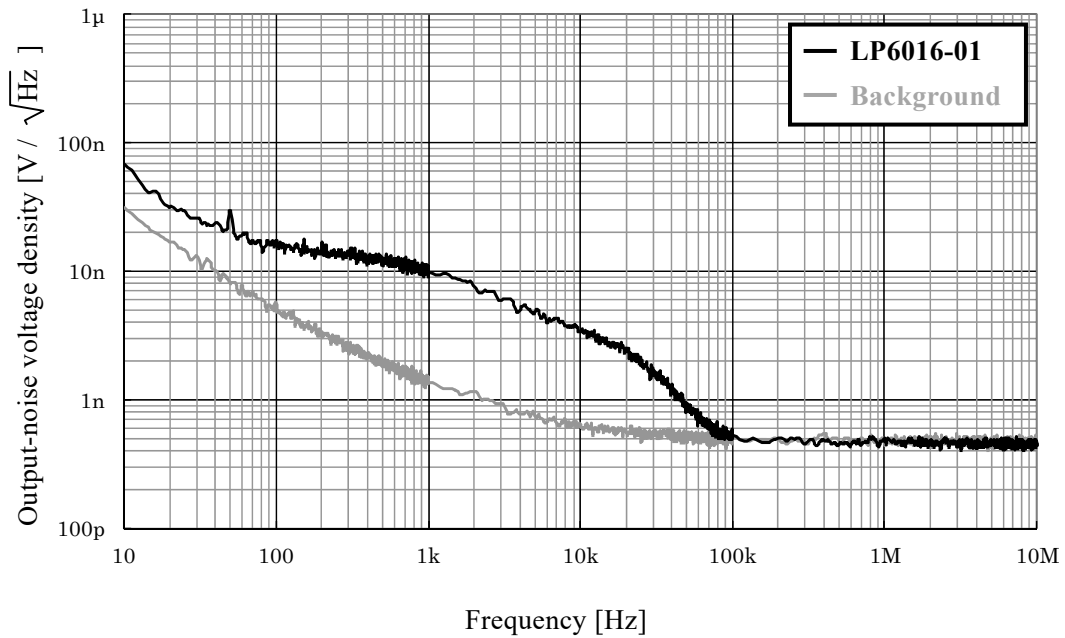

Figure 9-1 Output noise voltage density frequency characteristics

### 9.3 Time stability

The time stability of the output voltage after 60 minutes of warm-up is shown in Figure 9-2, which shows the characteristics of positive voltage output. The negative voltage output has the same characteristics.

Conditions: +16.1000 V, 100 mA, ambient temperature within  $23\text{ °C} \pm 3\text{ °C}$

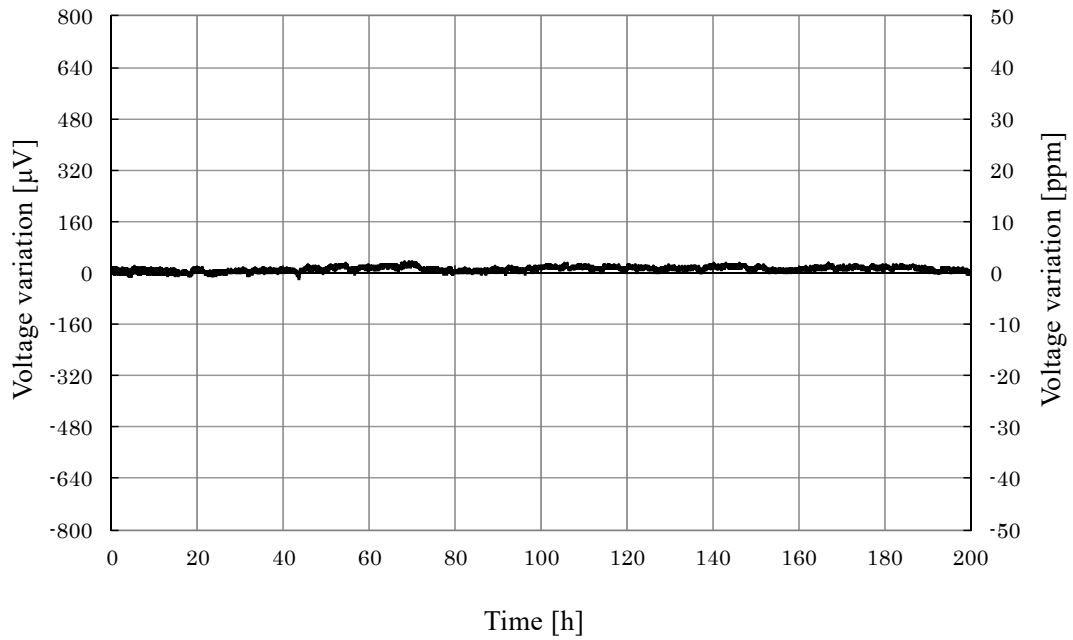

Figure 9-2 Time stability

## 9.4 Temperature coefficients

The temperature coefficients of the output voltage are shown in Figure 9-3 and Figure 9-4. The vertical axes in the figures are the normalized values at ambient temperature (23 °C).

Conditions:  $\pm 16.1000$  V, no load

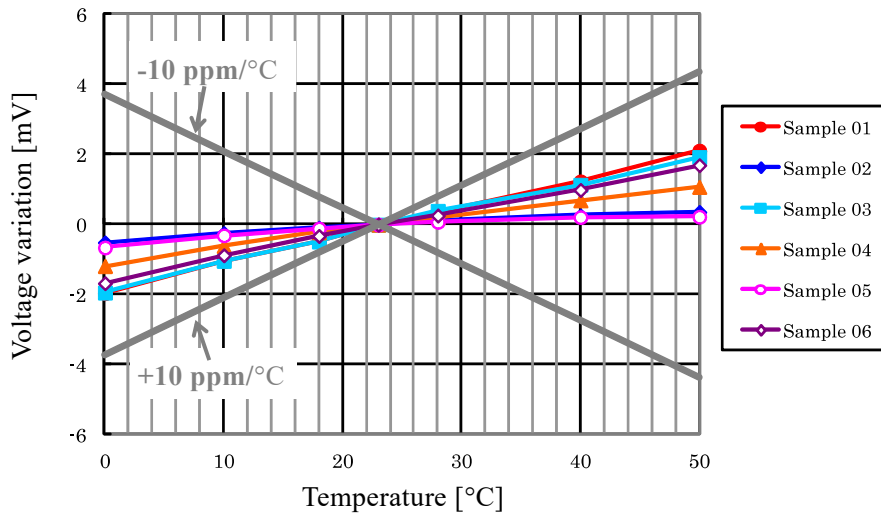

Figure 9-3 Temperature coefficients (positive output)

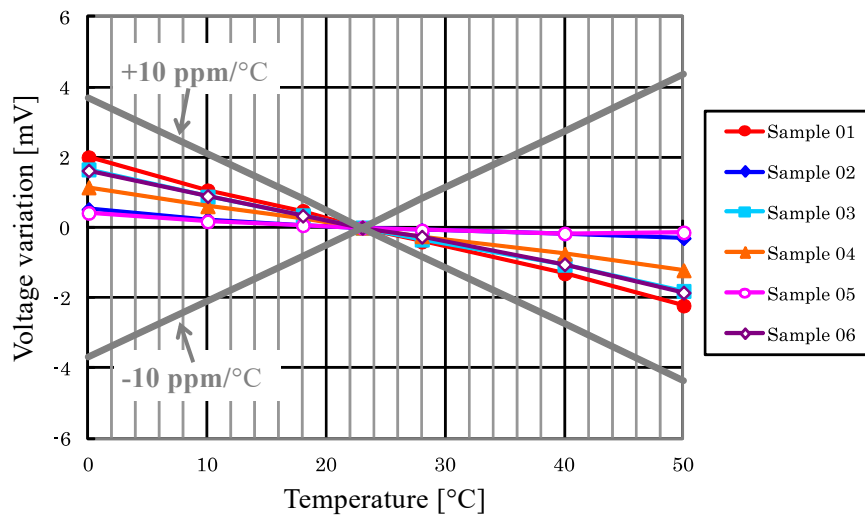
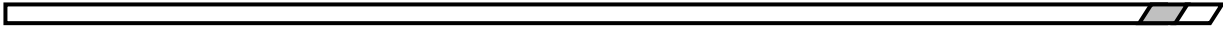

Figure 9-4 Temperature coefficients (negative output)







# WARRANTY

NF Corporation certifies that this product was thoroughly tested and inspected and found to comply with its published specifications when it was shipped from our factory. In the unlikely event that you experience an issue during use, please contact our company or an authorized agency from which you purchased the product.

All NF Corporation products are warranted against defects in materials and workmanship for a period of one year from the date of shipment. During the warranty period, NF Corporation will repair the defective product without any charge for the parts and labor.

For repair service under warranty, the product must be returned to either NF Corporation or an authorized agent. The Purchaser shall prepay all shipping costs, duties, and taxes for the product to NF Corporation from another country, and NF Corporation shall pay shipping charges to return the product to the purchaser.

This warranty shall not apply when corresponding to the following particulars.

- A) Failure caused by improper handling or use of the product in a manner that does not conform with the provisions of the Instruction Manual.
- B) Failure or damage caused by transport, dropping, or other handling of the product after purchase.
- C) Failure caused by repair, adjustment, or modification of the product by a company, organization, or individual not approved by NF Corporation.
- D) Failure caused by abnormal voltage or the effect of equipment connected to this product.
- E) Failure caused by the effect of supply parts from the customer.
- F) Failure caused by such as corrosion from the use of caustic gases, organic solvents, and chemicals.
- G) Failure caused by insects or small animal that invaded from the outside.
- H) Failure or damage caused by fire, earthquakes, flood damage, lightning, war, or other uncontrollable events.
- I) Failure caused by unforeseen reasons due to the limits of the technology when shipped from our company.
- J) Replacement and replenishment of consumables such as batteries.

**NF Corporation**

## Request for Repair

When a failure occurred and the product was found to be defective or you have any uncertainty, please contact NF Corporation or an authorized agent.

In such a case, let us know the model name (or product name), serial number (SERIAL No. given on the nomenclature plate), and symptoms and operating conditions in as much detail as possible.

Though we will make efforts to reduce the repair period, when five or more years have passed since you purchased the product, it may take time due to, for instance, repair parts being out of stock.

Also, if the production of repair parts is discontinued, the product is seriously damaged, or the product is modified, we may decline the repair.



If there are any misplaced or missing pages, we will replace the manual.  
Contact a sales representative.

#### NOTES

- Reproduction of the contents of this manual is forbidden by applicable laws.
- The contents of this manual may be revised without notice.
- Information provided in this manual is intended to be accurate and reliable. However, we assume no responsibility for any damage regarding the contents of this manual.
- We assume no responsibility for influences resulting from the operations in this manual.

Copyright 2019-2022. **NF Corporation**

#### LP6016-01 INSTRUCTION MANUAL

### **NF Corporation**

6-3-20, Tsunashima Higashi, Kohoku-ku, Yokohama  
223-8508 Japan

Phone: +81-45-545-8111 Fax: +81-45-545-8191





