



GAIN-PHASE ANALYZER

FRA51602

INSTRUCTION MANUAL
(REMOTE CONTROL)

NF Corporation

DA00066613-002

GAIN-PHASE ANALYZER

FRA51602

INSTRUCTION MANUAL

(REMOTE CONTROL)

Registered Trademarks

National Instruments, LabVIEW, and Measurement Studio are registered trademarks of National Instruments Corporation in the United States.

WINDOWS® EMBEDDED 8.1 INDUSTRY PRO

Used with permission from Microsoft.

Other company names and product names used in this instruction manual may be trademarks or registered trademarks of their respective companies.

Copyright

NI Measurement Studio

Copyright (C) 2017 National Instruments Corporation

All Rights Reserved.

Introduction

This manual explains remote control of the FRA51602 gain-phase analyzer.

■ The manuals listed below are available for the FRA51602.

● FRA51602 Instruction Manual (basic)

This manual covers operation of the FRA51602 from the panel, specifications, maintenance, and other basic matters.

● FRA51602 Instruction Manual (remote control)

This manual covers remote control of the FRA51602.

■ This Instruction Manual comprises the following chapters.

1. Preparation before Use

This chapter explains how to set up the interface and matters that require particular attention.

2. Switching between Remote and Local Modes

This chapter explains how to switch between the remote operation mode and the local operation mode of the instrument.

3. Responding to Interface Messages

Mainly, responses for IEEE-488.1 messages are shown.

4. List of commands and command tree

This chapter provides an overview of all commands.

5. Commands

This chapter explains each command in detail.

6. Status System

This chapter explains the status system.

7. Command Execution Examples

This chapter explains examples of executing measurement commands.

8. Error Messages

This chapter explains error messages related to remote operation

Contents

	Page
1. Preparation before Use.....	1-1
1.1 Selection of the remote control interface	1-2
1.2 USB overview	1-4
1.2.1 Preparation of the controller.....	1-4
1.2.2 Preparation of the FRA51602.....	1-5
1.2.3 Identification of USB instruments	1-6
1.3 GPIB overview	1-6
1.3.1 Preparation of the controller.....	1-6
1.3.2 Preparation of the FRA51602.....	1-6
1.3.3 Important points for using GPIB	1-7
1.3.4 Basic GPIB specifications	1-7
1.4 RS-232 overview	1-8
1.4.1 Preparing the controller.....	1-8
1.4.2 Preparing the FRA51602	1-8
1.4.3 Connection.....	1-10
1.4.4 Restrictions and cautions	1-11
1.5 LAN overview.....	1-12
1.5.1 Preparing the controller.....	1-12
1.5.2 Preparing the FRA51602	1-12
1.5.3 Connection.....	1-14
1.5.4 Restrictions and cautions	1-14
1.6 Communication cautions	1-14
2. Switching between Remote and Local Modes.....	2-1
3. Responding to Interface Messages	3-1
4. List of commands and command tree	4-1
4.1 List of commands.....	4-2
4.2 Command tree	4-6
5. Commands	5-1
5.1 Overview	5-2
5.1.1 Notation	5-2
5.1.2 Command types	5-2
5.2 Sequential commands	5-12
5.3 Command details	5-13
5.3.1 *CLS	5-13
5.3.2 *ESE <value>.....	5-13
5.3.3 *ESR?	5-13
5.3.4 *SRE <value>	5-13
5.3.5 *STB?	5-13
5.3.6 *IDN?	5-14
5.3.7 *RST	5-14
5.3.8 *TST?	5-14
5.3.9 *OPC	5-14
5.3.10 *RCL <value>.....	5-14
5.3.11 *SAV <value>	5-14
5.3.12 *WAI.....	5-14
5.3.13 :CALCulate:DATA:MARKer? <param>	5-15
5.3.14 :CALCulate:DATA:MARKer:ACTive <param>,<seq>	5-15
5.3.15 :CALCulate:DATA:MARKer:MODE <mode>	5-15
5.3.16 :CALCulate:DATA:MARKer:SEARch <param>	5-16
5.3.17 :CALCulate:DATA:MARKer:SEARch:AUTO <param>.....	5-17
5.3.18 :CALCulate:DATA:MARKer:VALue <param>,<value>	5-17
5.3.19 :CALCulate:FORMat <param1>,<param2>,<param3>	5-18

Contents

5.3.20 :CALCulate:FORMat:UPHase:SHIFt <value>	5-18
5.3.21 :CALCulate:MATH[:EXPRession]:NAME <mode>	5-18
5.3.22 :DATA[:DATA]? <param>[,<start>,<num>]	5-19
5.3.23 :DATA:DELEte <memory>	5-19
5.3.24 :DATA:POINts? <param>	5-19
5.3.25 :DATA:RECall <memory>,<dist>	5-20
5.3.26 :DATA:STATe:DEFine “<name>”, <memory>	5-20
5.3.27 :DATA:STORe <memory>,<src>.....	5-20
5.3.28 :DISPlay:BRIGhtness <value>	5-20
5.3.29 :DISPlay[:WINDow]:MODE <mode>	5-21
5.3.30 :DISPlay[:WINDow]:TEXT[:DATA] “<title>”	5-21
5.3.31 :DISPlay[:WINDow]:TRACe:GRATICule:GRID:LINE <param>	5-21
5.3.32 :DISPlay[:WINDow]:TRACe:GRATICule:GRID:STYLe <param>	5-21
5.3.33 :DISPlay[:WINDow]:TRACe:MY1:STATe <sw>	5-22
5.3.34 :DISPlay[:WINDow]:TRACe:MY2:STATe <sw>	5-22
5.3.35 :DISPlay[:WINDow]:TRACe:RY1:STATe <sw>	5-22
5.3.36 :DISPlay[:WINDow]:TRACe:RY2:STATe <sw>	5-22
5.3.37 :DISPlay[:WINDow]:TRACe:SCALe:AUTO <sw>	5-23
5.3.38 :DISPlay[:WINDow]:TRACe:X:SCALe:LEFT <value>	5-23
5.3.39 :DISPlay[:WINDow]:TRACe:X:SCALe:RIGHT <value>	5-23
5.3.40 :DISPlay[:WINDow]:TRACe:X:SPACing <param>	5-24
5.3.41 :DISPlay[:WINDow]:TRACe:Y1:SCALe:BOTTom <value>	5-24
5.3.42 :DISPlay[:WINDow]:TRACe:Y1:SCALe:TOP <value>	5-24
5.3.43 :DISPlay[:WINDow]:TRACe:Y1:SPACing <param>	5-24
5.3.44 :DISPlay[:WINDow]:TRACe:Y2:SCALe:BOTTom <value>	5-25
5.3.45 :DISPlay[:WINDow]:TRACe:Y2:SCALe:TOP <value>	5-25
5.3.46 :DISPlay[:WINDow]:TRACe:Y2:SPACing <param>	5-25
5.3.47 :HCOPY:DATA?	5-25
5.3.48 :INPut:FILTer:JW <value>	5-26
5.3.49 :INPut:GAIN <value1>,<value2>	5-26
5.3.50 :INPut:GAIN:INVert <sw>	5-26
5.3.51 :MEMory:CLear <obj>	5-26
5.3.52 :MEMory:COpy:NAME <dist>	5-26
5.3.53 :MEMory:STATe:DEFine “<name>”, <memory>	5-27
5.3.54 :MEMory:STATe:DELEte <memory>	5-27
5.3.55 :OUTPut[:STATe] <param>	5-27
5.3.56 :OUTPut:STOP:PHASe <param>	5-27
5.3.57 :OUTPut:TRIGger <mode>	5-28
5.3.58 :ROUTe:BIAS:TERMinals <param>	5-28
5.3.59 :SENSe:AVERAge:COUNT <value>,<param>	5-28
5.3.60 :SENSe:AVERAge[:STATe] <mode>	5-29
5.3.61 :SENSe:AVERAge:TYPE?	5-29
5.3.62 :SENSe:CORRection:COLLect[:ACQuire]	5-29
5.3.63 :SENSe:CORRection:EQUalizing <sw>	5-29
5.3.64 :SENSe:SMOothing:POINts <value>	5-29
5.3.65 :SENSe:VOLTagE:AC:PROTection:BEEPer <sw>	5-30
5.3.66 :SENSe:VOLTagE:AC:PROTection[:LEVel] <value>[<unit>],<ch>	5-30
5.3.67 :SENSe:VOLTagE:AC:PROTection:SWEEp:STOP <sw>	5-30
5.3.68 :SENSe:VOLTagE:AC:RANGe <ch1param>,<ch2param>	5-31
5.3.69 :SOURce:BIAS <value>[<unit>]	5-31
5.3.70 :SOURce:FREQuency:AFC:SOURce <ch>	5-31
5.3.71 :SOURce:FREQuency:AFC:STATe <sw>	5-31
5.3.72 :SOURce:FREQuency:AFC:TOLerance <value>	5-32
5.3.73 :SOURce:FREQuency:AFC:TYPE <param>	5-32
5.3.74 :SOURce:FREQuency:CENTer <value>[<unit>]	5-33
5.3.75 :SOURce:FREQuency[:CW]:FIXed <value>[<unit>]	5-33
5.3.76 :SOURce:FREQuency:SPAN <value>[<unit>]	5-34
5.3.77 :SOURce:FREQuency:STARt <value>[<unit>]	5-34

Contents

5.3.78	:SOURce:FREQuency:STOP <value>[<unit>]	5-35
5.3.79	:SOURce:FREQuency:TRANSition <mode>	5-35
5.3.80	:SOURce:FUNCTion[:SHAPE] <param>	5-35
5.3.81	:SOURce:ROSCillator:OUTPut[:STATe] <sw>	5-36
5.3.82	:SOURce:ROSCillator:SOURce <param>	5-36
5.3.83	:SOURce:SEQuence:LENGth <value>	5-36
5.3.84	:SOURce:SWEEp:DIRection?	5-36
5.3.85	:SOURce:SWEEp:POINts <value>	5-36
5.3.86	:SOURce:SWEEp:SPACing <param>	5-37
5.3.87	:SOURce:VOLTage:ALC:COUNT <value>	5-37
5.3.88	:SOURce:VOLTage:ALC:FACTor <value>	5-37
5.3.89	:SOURce:VOLTage:ALC:LIMit[:AMPLitude] <value>[<unit>]	5-37
5.3.90	:SOURce:VOLTage:ALC:RLEVel <value>[<unit>]	5-38
5.3.91	:SOURce:VOLTage:ALC:SOURce <ch>	5-38
5.3.92	:SOURce:VOLTage:ALC[:STATe] <sw>	5-38
5.3.93	:SOURce:VOLTage:ALC:TOLerance <value>	5-38
5.3.94	:SOURce:VOLTage[:LEVel][:IMMEDIATE][:AMPLitude] <value>	5-39
5.3.95	:SOURce:VOLTage:SLEW:TYPE <param>	5-39
5.3.96	:STATus:OPERation:CONDition?	5-39
5.3.97	:STATus:OPERation:ENABLE <value>	5-39
5.3.98	:STATus:OPERation[:EVENT]?	5-39
5.3.99	:STATus:OPERation:NTRansition <value>	5-40
5.3.100	:STATus:OPERation:PTRansition <value>	5-40
5.3.101	:SYSTem:BEEPer <sw>	5-40
5.3.102	:SYSTem:DATE <year>,<month>,<day>	5-40
5.3.103	:SYSTem:ERRor?	5-41
5.3.104	:SYSTem:LOCal	5-41
5.3.105	:SYSTem:REMote	5-41
5.3.106	:SYSTem:RWLock	5-41
5.3.107	:SYSTem:TIME <hour>,<minute>,<second>	5-41
5.3.108	:TRIGger:ABORT	5-41
5.3.109	:TRIGger:DELay <value>,<param>	5-42
5.3.110	:TRIGger:DELay:TYPE?	5-42
5.3.111	:TRIGger[:IMMEDIATE] <param>	5-42
5.3.112	:TRIGger:SOURce <param>	5-42
5.3.113	:TRIGger:STTDelay <value>,<param>	5-43
5.3.114	:TRIGger:STTDelay:TYPE?	5-43
6.	Status System	6-1
6.1	Status system overview	6-2
6.2	Status byte	6-3
6.3	Standard event status	6-4
6.4	Operation status	6-6
7.	Command Execution Examples	7-1
7.1	Spot measurement	7-2
7.2	Sweep measurement	7-3
8.	Error Messages	8-1

Figures and Tables

	Page
Figure 1-1 RS-232 cable wiring diagram.....	1-10
Figure 5-1 Common command syntax.....	5-2
Figure 5-2 Subsystem command syntax.....	5-3
Figure 5-3 Numerical parameter syntax (<NRf>)	5-5
Figure 5-4 Numerical parameter syntax (<NR1>)	5-5
Figure 5-5 Numerical parameter syntax (<NR2>)	5-5
Figure 5-6 Numerical parameter syntax (<NR3>)	5-5
Figure 5-7 Mantissa syntax.....	5-6
Figure 5-8 Exponent syntax	5-6
Figure 5-9 Discrete parameter syntax (<DISC>).....	5-6
Figure 5-10 Boolean parameter syntax (<BOL>)	5-7
Figure 5-11 Text string parameters (<STR>).....	5-7
Figure 5-12 Block parameter syntax (<BLK>)	5-8
Figure 5-13 Suffix syntax	5-8
Figure 5-14 Program message syntax	5-9
Figure 5-15 Response message syntax	5-9
Figure 5-16 Integer response data syntax (<NR1>)	5-10
Figure 5-17 NR2 numerical response data syntax (<NR2>)	5-10
Figure 5-18 NR3 numerical response data syntax (<NR3>)	5-10
Figure 5-19 Discrete response data syntax (<DISC>)	5-11
Figure 5-20 Numerical Boolean response data syntax (<NBOL>)	5-11
Figure 5-21 Text string response data syntax (<STR>)	5-11
Figure 5-22 Defined-length arbitrary block response data syntax (<DBLK>).....	5-11
Figure 6-1 Status system	6-2
Figure 6-2 Standard event status structure	6-4
Figure 6-3 Operation status structure	6-6
Table 3-1 Responses to interface messages	3-2
Table 5-1 Keywords that are accepted or not accepted by the instrument (for the case of “OUTPut”).....	5-4
Table 6-1 Status byte register definitions	6-3
Table 6-2 Content of the standard event status register	6-4
Table 6-3 Contents of the operation condition register and event register	6-7
Table 6-4 Operation transition filter and event register transitions	6-8
Table 8-1 Error messages	8-2

1. Preparation before Use

- 1.1 Selection of the remote control interface 1-2
- 1.2 USB overview 1-4
- 1.3 GPIB overview 1-6
- 1.4 RS-232 overview 1-8
- 1.5 LAN overview..... 1-12
- 1.6 Communication cautions 1-14

The FRA51602 can be controlled remotely via USB, GPIB, RS-232, or LAN interfaces. Program messages can be sent from the controller to achieve the same control of operation as when using the control panel of the instrument. Response messages received from the instrument contain measurement values and configuration status. Connectors for the various interfaces are provided on the rear panel of the FRA51602.

1.1 Selection of the remote control interface

USB, GPIB, RS-232, or LAN can be selected as the remote control interface for the FRA51602. It is not possible to use more than one interface at the same time.

■ Displaying the current interface

Press the **MENU** key and touch the 2/2 [Remote] option on the top level menu to display the [Remote] dialog box and the interface that is currently set.

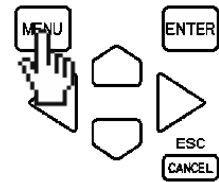
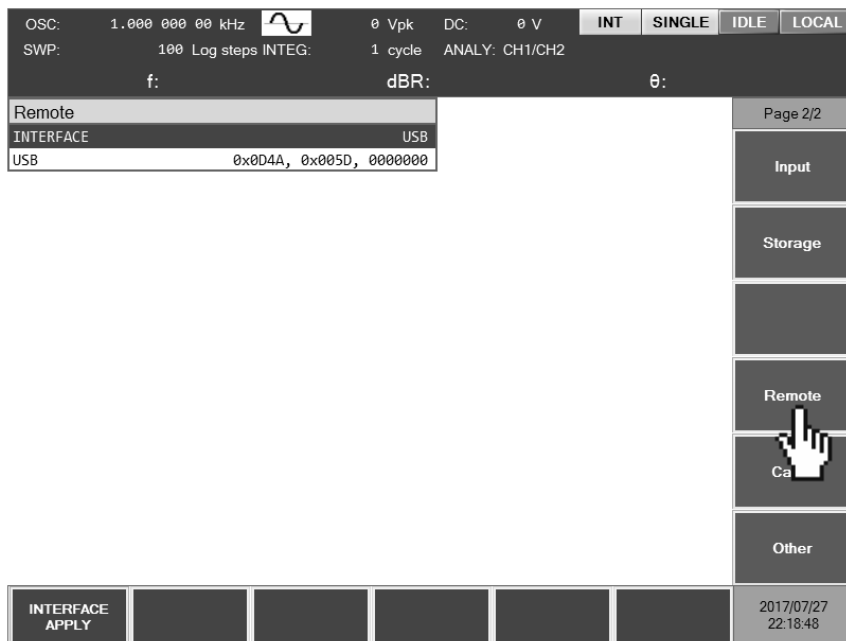

■ Setting the interface

With [Remote] dialog box displayed, move the cursor to [INTERFACE] and press the [ENTER] to select the communication interface to be used.

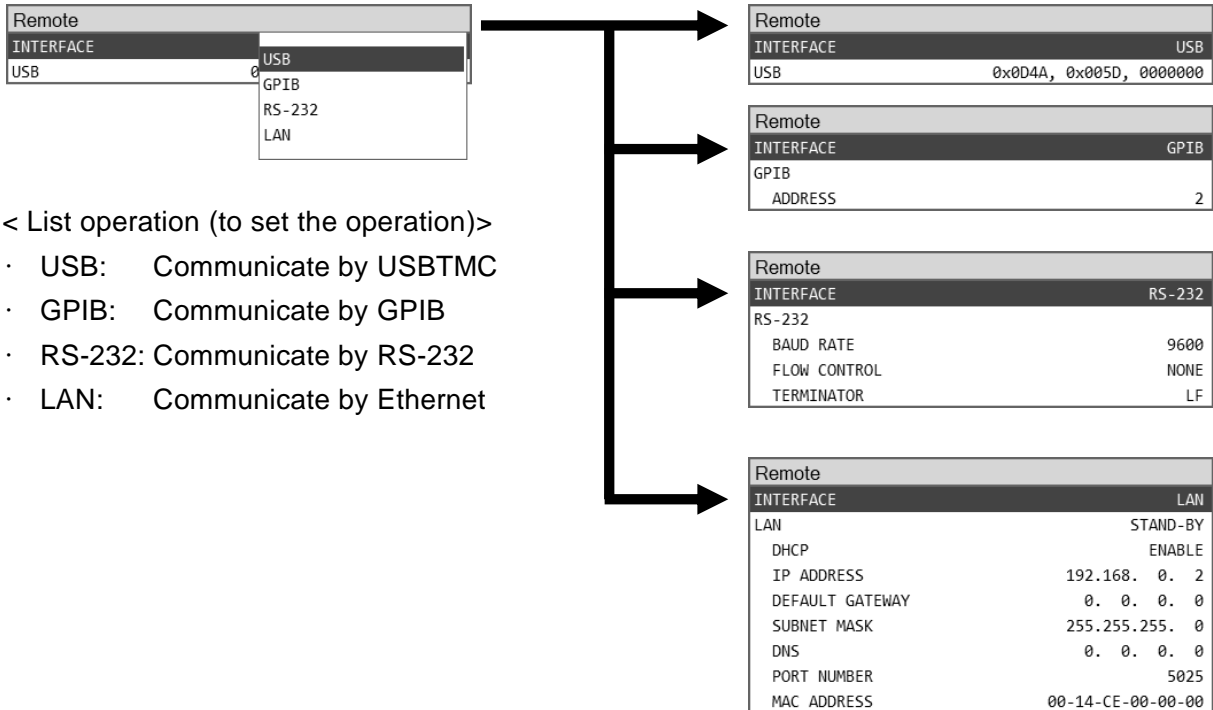

The communication interface can be changed by selecting from the [INTERFACE] menu and then pressing the [INTERFACE APPLY] function key.



1.2 USB overview

1.2.1 Preparation of the controller

To use the USB interface, prepare a controller that is equipped with a USB interface (a computer to be used for control).

Install a USBTMC driver on the controller. Usually, this driver supports the USB488 subclass and can perform control over USB that is nearly the same as GPIB.

USBTMC: Universal Serial Bus Test and Measurement Class

That driver is included in the hardware products and software products provided by various manufacturers that supply the VISA library. If you do not have a VISA library license, it is necessary to obtain one.

VISA: Virtual Instrument Software Architecture

Using the VISA library enables unified operation over any USB, GPIB, RS-232, or LAN interface, within the respective supported ranges.

This instrument has been confirmed to operate on the NI-VISA supplied by National Instruments.

1.2.2 Preparation of the FRA51602

- The [Remote] dialog box

The information that is displayed when the USB interface has been selected as shown below.



Vendor ID, product ID, and manufacture number

- Vendor ID Vendor ID = 0x0D4A (hexadecimal notation): a number that indicates the company

In decimal notation, the number is 3402.

- Product ID Product ID = 0x005D (hexadecimal notation): The product number for the FRA51602. In decimal notation, the number is 93.

- Manufacture number Serial Number = 0000000 Example: a 7-digit number that is specific to the instrument

- Message terminator

A set of commands and responses must end with a terminator that indicates the end.

The response message terminator that is sent by the FRA51602 is always LF^EOM.

The terminators used for program messages received by the FRA51602 can be any of those listed below.

- LF Line Feed code
- LF^EOM LF accompanying an EOM (END message)
- (final code)^EOM EOM (END message) added to the final code

1.2.3 Identification of USB instruments

The FRA51602 is connected directly to the USB connector of the computer by a commercial USB cable. The instrument may not operate correctly if the connection is made via a USB hub.

The FRA51602 is automatically recognized when connected via USB to a computer on which a USBTMC class driver has been installed. The FRA51602 instruments in a system are identified by the vendor ID, product ID, and serial number, which are displayed in the [Remote] dialog box. If the instrument is not automatically recognized, specify those items directly so that the instrument is recognized.

1.3 GPIB overview

The GPIB interface is not intended for use in an environment with electronic noise .

1.3.1 Preparation of the controller

To use the GPIB interface, install a commercial GPIB interface card on the controller (computer used for control) and connect the FRA51602 to the connector on the interface card with a GPIB cable. Refer to the manual for the GPIB interface card for information on driver software.

1.3.2 Preparation of the FRA51602

The instruments in GPIB systems are identified by addresses that are specific to each instrument. Set a different GPIB address for each instrument.

■ [Remote] dialog box

When GPIB is selected, the display is as shown below.



GPIB address

■ Message terminator

A terminator must be placed at the end of a set of commands and responses.

The response message terminator that is sent by the FRA51602 is always LF^EOI.

The terminators used for program messages received by the FRA51602 can be any of those listed below.

- LF Line Feed code
- LF^EOI LF accompanying an EOI (END message)
- (final code)^EOI EOI (END message) added to the final code

1.3.3 Important points for using GPIB

- Turn off the power to all instruments that are connected to the bus before inserting or removing the GPIB connector cable.
- When using GPIB, turn on the power to all instruments that are connected to the bus.
- Up to 15 instruments, including the controller, can be connected to a single GPIB bus.
The following limitations apply to the length of cables.
 - The total cable length cannot exceed 2 m times the number of instruments or 20 m, whichever is less.
 - The length of one cable cannot exceed 4 m.
- Set a different value for the GPIB address of each instrument. If there instruments on the bus that have the same address, the instruments may be damaged by output collision.

1.3.4 Basic GPIB specifications

■ GPIB compliance standards

IEEE std 488.1-1987 and IEEE std 488.2-1992

■ IEEE std 488.1-1987 interface functions

- SH1 All transmission flow control functions are supported.
- AH1 All receiving flow control functions are supported.
- T6 The basic talker, serial poll, and listener-specified talker release functions are supported; the talk-only function is not supported.
- L4 The basic listener function and the talker-specified listener release function are supported; the listen-only function is not supported.
- SR1 All service request functions are supported.
- RL1 All remote control functions are supported.
- PP0 The parallel poll function is not supported.
- DC1 The device clear function is supported.
- DT0 device trigger function is not supported.
- C0 The controller function is not supported.
- E1 Open collector drive

1.4 RS-232 overview

1.4.1 Preparing the controller

To use the RS-232 interface, prepare a controller (computer to be used for control) that is equipped with an RS-232 serial connector.

Match the parameters listed below on the FRA51602 and the controller.

- Baud rate 4800 to 230400 bps
- Data length 8 bits († 1)
- Stop bit length 1 for sending and 1 for receiving († 1)
- Parity None († 1)
- Flow control None/software/hardware
- Terminator LF/CR LF

† 1: This is fixed for the FRA51602. It cannot be changed.

1.4.2 Preparing the FRA51602

■ [Remote] dialog box

The information shown below is displayed when the RS-232 interface is selected.

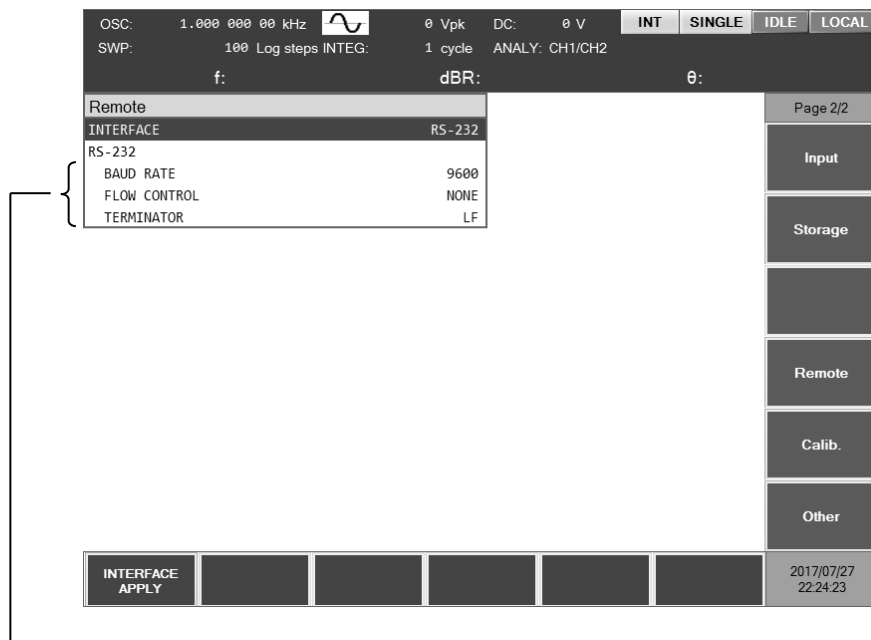

Baud rate, flow control, and terminator

■ Baud rate

This sets the communication speed. The baud rate is the same for both sending and receiving.

For communication speeds in excess of 19200 bps, higher speeds require lower cable capacitance and shorter cable length.

■ Flow control

This sets the flow control method.

NONE No flow control (default)

SOFT Software flow control

Communication is managed with flow codes (X-ON and X-OFF).

Reliable communication as possible for transmission and receiving, even with only a ground-only connecting cable. However, binary data cannot be transmitted and the effective speed may be lower.

In hexadecimal notation, X-ON is 0x11 and X-OFF is 0x13.

HARD Hardware flow control

Communication is managed with a hardware control line (RTS and CTS).

When flow control is enabled, communication is temporarily halted when the receive buffer is nearly full and resumed when the available buffer capacity is sufficient.

■ Terminator

A set of commands and responses must end with a terminator that indicates the end of the message.

LF The terminator is a one-character LF (Line Feed).

CRLF The terminator is a two-character combination of CR (Carriage Return) and LF.

In hexadecimal notation, CR is 0x0D and LF is 0x0A.

- For FRA51602 sending

The specified terminator is added to the end of the response message.

- For FRA51602 receiving

When the terminator that has been set for this instrument is received, the command is executed.

1.4.3 Connection

Prepare a commercially-available cable to use for the connecting cable. When connecting to the serial interface of a personal computer, the cable described below can be used.

Cable specifications: D-Sub, 9-pin, female-female, interlink, with ISO inch screws

To prevent operating problems due to electromagnetic interference or noise, a shielded cable must be used.

The minimum cable configuration for communication is RxD, TxD, and GND.

For hardware flow control, RTS and CTS are required.

To use hardware flow control, use an interlink cable (Fig. 1-1 (b)). Another cross or reverse connection method is to connect adjacent pins 7 and 8 (Fig. 1-1 (c)). With that type of cable, communication is possible, but hardware flow control cannot be used.

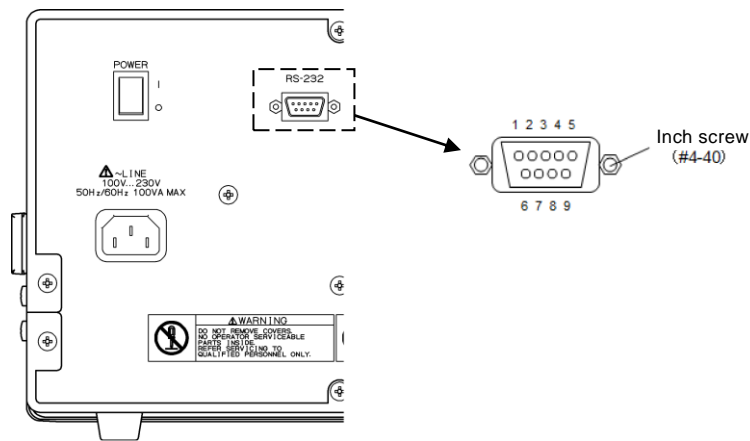

(a) Rear panel RS-232 connector

FRA51602		Personal computer (PC/AT, etc.)	
Signal	Pin	Pin	Signal
—	1	1	—
RxD	2	2	RxD
TxD	3	3	TxD
DTR	4	4	DTR
GND	5	5	GND
—	6	6	—
RTS	7	7	RTS
CTS	8	8	CTS
—	9	9	—
	Frame	Frame	

(b) Interlink wiring

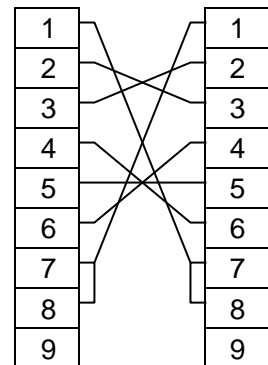

(c) Other cross wiring

Figure 1-1 RS-232 cable wiring diagram

1.4.4 Restrictions and cautions

- For the RS-232 interface, there is one-to-one connection between the controller and the FRA51602.

It is not possible to connect multiple instruments to one port in parallel.

- SRQ, and other functions that are specific to GPIB cannot be used.

For the remote control function, the :SYSTEM{:LOCAL|:REMOTE|:RWLOCK} command can be mostly replaced.

- Clear the receive buffer before beginning communication.

If the instrument power is turned on or off, or if the RS-232 connector is removed or inserted while the controller has an open RS-232 communication path, invalid data may be input to the receive buffer of the controller. For that reason, it is necessary to clear the receive buffer of the controller when a program on the controller opens or reopens communication (by initializing communication for example) before normal operation.

In the same way, invalid data may remain in the receive buffer of the FRA51602.

1.5 LAN overview

1.5.1 Preparing the controller

To use the LAN interface, prepare a controller (computer used for control) that is equipped with a LAN interface. The FRA51602 can communicate by using the TCP/IP protocol.

1.5.2 Preparing the FRA51602

■ [Remote] dialog box

The information shown below is displayed when the LAN interface is selected.

Remote		Page 2/2
INTERFACE	LAN	
LAN	STAND-BY	Input
DHCP	ENABLE	Storage
IP ADDRESS	192.168.0.2	
DEFAULT GATEWAY	0.0.0.0	Remote
SUBNET MASK	255.255.255.0	Calib.
DNS	0.0.0.0	Other
PORT NUMBER	5025	
MAC ADDRESS	00-14-CE-00-00-00	
INTERFACE APPLY		2017/07/27 22:24:14

LAN status, DHCP, IP address, default gateway, subnet mask, DNS, port number, and MAC address

■ LAN status

The current status of the LAN is displayed.

STAND-BY	Either the LAN has not been specified as the remote control interface or the system is preparing for startup.
NON-FAULT	The LAN setting is enabled and communication is possible.
FAULT	Communication is not possible. The reason for communication failure might be that the LAN cable has been removed from the connector, retrieval of the IP address by DHCP failed, or there is duplication of IP addresses, etc.

■ DHCP

When the DHCP state is ENABLE and [INTERFACE APPLY] is executed, an IP address request is sent to the DHCP server on the network.

If the DHCP is present, the IP address request ends normally and the returned IP address can be used for communication. If no DHCP server is detected or the IP address assignment did not end normally, the APIPA (Automatic Private IP Addressing) function automatically allocates an IP address in the range of 169.254.0.0 to 169.254.255.255.

■ IP address

In the IP (Internet Protocol), an address that identifies a instrument is set (logical address). The range of addresses from 192.168.0.0 to 192.168.255.255 is for private IP addresses that can be used freely within a small-scale local network (class C).

■ Default gateway

When accessing an external network, the IP address of the gateway that is used implicitly is set.

■ Subnet mask

A subnet mask is set to separate the IP addresses of a higher-level network from the IP addresses of lower-level network.

■ DNS

The IP address of the DNS server for resolving host names to IP addresses is set.

■ MAC address

This displays a instrument-specific address (physical address). It cannot be changed.

■ Port number

This is the port number that is used when the FRA51602 communicates using the TCP protocol. It cannot be changed. It is written in decimal notation.

■ LAN reset

This resets the LAN settings for the specified instrument to the factory settings.

When the cursor is over the LAN parameters in the [Remote] dialog box, it is shown in the function keys.

■ Message terminator

A set of commands and responses must end with a terminator that indicates the end of the message.

The terminator for response messages sent by the FRA51602 and the terminator for the program messages that are received by the FRA51602 are fixed as LF.

1.5.3 Connection

The FRA51602 can distinguish between a straight cable and a cross cable, so either type of cable can be used.

Use the type of cable that is compatible with the equipment to which the FRA51602 is being connected.

1.5.4 Restrictions and cautions

- GPIB-specific functions such as SRQ cannot be used.

The remote/local control function can be replaced by the :SYSTem{:LOCal|:REMote|:RWLock} command.

1.6 Communication cautions

■ Input buffer

- The commands that have been sent are temporarily stored in the input buffer, from where they are interpreted and executed in sequence.
The input buffer capacity is 100 KB (K = 1024). Even if program messages exceed that size, they are interpreted and secured in order.
- If an invalid command is encountered during interpretation and execution, an error results and none of the subsequent commands up to the program message terminator are executed.

■ Output buffer

- The output buffer capacity is 4096 KB (K = 1024).
- If the maximum capacity is exceeded, the output buffer is cleared and the query error bit of the standard event status register is set to 1. Subsequently, command interpretation and execution proceeds in the normal manner, but all generated response messages are discarded up to the program message terminator.

■ Error queue

- The queue can hold up to 16 error messages.
- If there are more than 16 error messages, the 16th message returns “Queue overflow”. Subsequent error messages are discarded. The error messages up to the 15th message are retained.

■ Program message terminator

When commands are sent from the controller, be sure to append the program message terminator, which is either LF (Line Feed, 0x0A hex) or CRLF (Carriage Return, 0x0D hex + Line Feed, 0x0A hex) to the end of the message. Alternatively, place an EOI (END message) byte at the end. If commands are sent without LF, CRLF, or EOI appended, the instrument may

not operate properly.

Depending on the driver software used by the computer that is used for control, the program message terminator may not be output unless the terminator is specified separately from the command itself. The line feed (LF) is sometimes written as new line (NL), but the binary code is the same in either case.

For the RS-232 and LAN interfaces, there is no END message concept, so EOI is not appended.

■ Control for RS-232 and LAN

GPIB-specific functions cannot be used. Examples are shown below.

Receiving GTL (Go To Local) messages

Receiving LLO (Local Lockout) messages

Receiving GET (Group Execute Trigger) messages

Receiving REN (Remote Enable) messages

Sending SRQ (Service Request) messages

Serial polling (receiving SPE or SPD and sending a status byte)

Sending an END message (EOI signal to serve as a message terminator)

1. Preparation before Use

2. Switching between Remote and Local Modes

The FRA51602 has two operating modes relevant to remote control: remote and local.

In the local mode, all panel operations are enabled. In the remote mode, all panel operations other than return to local mode and power-off are disabled.

■ Switching to the remote mode

Normally, operation from GPIB switches the instrument to the remote mode. That is a function of the driver on the controller side. According to the communication standard, asserting the REN line and specifying to a listener instrument sets the instrument to the remote mode. The operation is the same for USB (USBTMC).

■ Switching to the local mode

Pressing the LOCAL key on the front panel returns the instrument to the local mode (except when local lockout is enabled).

When a GTL command is sent from the controller or the REN line returns false, local mode operation is possible. If the GPIB cable is removed, the REN becomes false, so the instrument is returned to local mode. For USB, too, removing the cable returns the instrument to local mode.

■ Disabling local panel operation

When the controller specifies local lockout, unintentional local operations are disabled. When local lockout is in effect, the instrument cannot be returned to the local mode by pressing the LOCAL key.

Even when local lockout is in effect, local operation can be enabled from the controller.

■ Remote and local operation with the RS-232 and LAN interfaces

If a command is sent to the FRA51602, the instrument goes into remote mode. Pressing the LOCAL key returns the instrument to local mode and enables operation from the panel.

For the RS-232 and LAN interface, the commands listed below can be used.

:SYSTem:LOCal (change to local mode)
:SYSTem:REMote (change to remote mode)
:SYSTem:RWLock (change to remote mode with local lockout)

■ Displaying the remote control mode

It is possible to check the current status of the instrument by looking at the remote control status display in the upper part of the screen.

LOCAL	Local mode
REMOTE	Remote mode
LLO	Local lockout mode
DISABLE	Remote control disabled

This is displayed when remote control is disabled, such as when the remote interface is being set up.

3. Responding to Interface Messages

Mainly the IEEE-488.1 interface message responses are described in the following table.

Table 3-1 Responses to interface messages

Message	Function
IFC	< InterFace Clear > The GPIB interface is initialized. The specified listener and talker are released.
DCL,SDC	< Device CLear >, < Selected Device Clear > The input buffer is cleared and command interpretation and execution are stopped. The output buffer is cleared and status byte register bit 4 (MAV) is cleared.
LLO	< Local LockOut > Switching from the remote mode to the local mode by pressing the <input type="button" value="LOCAL"/> key is disabled.
GTL	< Go To Local > This switches to the local mode.
GET	< Group Execute Trigger > This executes a trigger. The operation is the same as for when the *TRG command is executed.

The method that is used for sending interface messages from the controller varies with the instrument driver. For more information, refer to the manual for each particular driver.

For RS-232 and LAN interfaces, substitute functions are available for some of them.

4. List of commands and command tree

- 4.1 List of commands..... 4-2
- 4.2 Command tree 4-6

4.1 List of commands

The remote control commands for the FRA51602 are listed in the tables that follow.

The meanings of the symbols used in the tables are described below.

The descriptions here are in short-form format, which omits all optional keywords. For the long-form formats of commands and parameters, refer to the pages listed in the details column.

Supplement: Commands that perform a query end with a question mark (?). In these tables, queries are omitted for functions for which setting and query are both possible.

Furthermore, the R/W column in the tables indicates whether or not a command is a query (R) and/or setting (W), and the *RST column indicates whether or not initialization is performed by the *RST command.

[Measurement function commands]

Commands	Function	R/W	*RST	Details
:OUTP	Output status	R/W	✓	P 5-27
:SOUR:SWE:DIR?	Get sweep direction	R	—	P 5-36
:TRIG	Start measurement	W	—	P 5-42
:TRIG:ABOR	Abort measurement	W	—	P 5-41
:DATA:POIN?	Get number of sweep measurement data points	R	—	P 5-19
:DATA?	Get measurement data	R	—	P 5-19

[OSC commands]

Commands	Function	R/W	*RST	Details
:SOUR:FREQ	Spot frequency	R/W	✓	P 5-31
:SOUR:VOLT	Internal oscillator amplitude	R/W	✓	P 5-39
:SOUR:BIAS	DC bias	R/W	✓	P 5-31
:ROUT:BIAS:TERM	DC bias output destination	R/W	✓	P 5-28
:OUTP:TRIG	Trigger synchronization driving	R/W	✓	P 5-27
:SOUR:VOLT:SLEW:TYPE	Oscillator on/off mode	R/W	✓	P 5-39
:OUTP:STOP:PHAS	Stop mode	R/W	✓	P 5-27
:SOUR:FUNC	Internal oscillator waveform	R/W	✓	P 5-35
:SOUR:ROSC:SOUR	10MHz REF IN status	R/W	✓	P 5-36
:SOUR:ROSC:OUTP	10MHz REF OUT output	R/W	✓	P 5-36
:SOUR:VOLT:ALC	Amplitude compression status	R/W	✓	P 5-37
:SOUR:VOLT:ALC:SOUR	Amplitude compression reference channel	R/W	✓	P 5-38
:SOUR:VOLT:ALC:RLEV	Amplitude compression reference level	R/W	✓	P 5-38
:SOUR:VOLT:ALC:LIM	Amplitude compression output limit	R/W	✓	P 5-37
:SOUR:VOLT:ALC:TOL	Amplitude compression tolerance	R/W	✓	P 5-38
:SOUR:VOLT:ALC:COUN	Number of amplitude compression retries	R/W	✓	P 5-37
:SOUR:VOLT:ALC:FAC	Amplitude compression correction factor	R/W	✓	P 5-37

4. List of commands and command tree

[Measure commands]

Commands	Function	R/W	*RST	Details
:SENS:AVER	Averaging mode	R/W	✓	P 5-28
:SENS:AVER:COUN	Averaging interval, averaging time	R/W	✓	P 5-28
:SENS:AVER:TYPE?	Get the current average setting type	R	—	P 5-29
:TRIG:STTD	Measurement start delay	R/W	✓	P 5-43
:TRIG:STTD:TYPE?	Get the operation measurement start delay type	R	—	P 5-43
:TRIG:DEL	Measurement delay	R/W	✓	P 5-42
:TRIG:DEL:TYPE?	Get the current measurement delay	R	—	P 5-42
:INP:FILT:JW	Differentiation processing	R/W	✓	P 5-26

[Sweep commands]

Commands	Function	R/W	*RST	Details
:SOUR:SEQ:LENG	Sequence sweep	R/W	—	P 5-36
:SOUR:FREQ:STAR	Sweep starting frequency	R/W	✓	P 5-34
:SOUR:FREQ:STOP	Sweep ending frequency	R/W	✓	P 5-35
:SOUR:FREQ:CENT	Sweep central frequency	R/W	✓	P 5-33
:SOUR:FREQ:SPAN	Sweep span frequency	R/W	✓	P 5-34
:SOUR:SWE:POIN	Number of sweep points	R/W	✓	P 5-36
:SOUR:SWE:SPAC	Sweep resolution	R/W	✓	P 5-37
:TRIG:SOUR	Repeat mode	R/W	✓	P 5-41
:SOUR:FREQ:TRAN	Frequency transition mode	R/W	✓	P 5-35
:SOUR:FREQ:AFC:STAT	Slow sweep mode	R/W	✓	P 5-31
:SOUR:FREQ:AFC:SOUR	Slow sweep reference channel	R/W	✓	P 5-31
:SOUR:FREQ:AFC:TYPE	Slow sweep monitoring parameters	R/W	✓	P 5-32
:SOUR:FREQ:AFC:TOL	Slow sweep permissible quantity	R/W	✓	P 5-32

[Graph commands]

Commands	Function	R/W	*RST	Details
:DISP:TEXT	Graph title	R/W	✓	P 5-21
:DISP:MODE	Graph display format	R/W	✓	P 5-21
:DISP:TRAC:GRAT:GRID:LINE	Grid lines	R/W	✓	P 5-21
:DISP:TRAC:GRAT:GRID:STYL	Grid display style	R/W	✓	P 5-21
:CALC:FORM	X, Y1, and Y2 axis formats	R/W	✓	P 5-18
:DISP:TRAC:MY1:STAT	MEAS Y1 display status	R/W	✓	P 5-22
:DISP:TRAC:MY2:STAT	MEAS Y2 display status	R/W	✓	P 5-22
:DISP:TRAC:RY1:STAT	REF Y1 display status	R/W	✓	P 5-22
:DISP:TRAC:RY2:STAT	REF Y2 display status	R/W	✓	P 5-22
:CALC:MATH:NAME	Analysis mode	R/W	✓	P 5-18
:SENS:SMO:POIN	Phase moving average	R/W	✓	P 5-29
:CALC:FORM:UPH:SHIF	Execute phase shift	W	—	P 5-18
:DISP:TRAC:SCAL:AUTO	Auto scaling	R/W	✓	P 5-22
:DISP:TRAC:X:SCAL:LEFT	X axis lower limit	R/W	✓	P 5-23
:DISP:TRAC:X:SCAL:RIGH	X axis upper limit	R/W	✓	P 5-23
:DISP:TRAC:X:SPAC	X axis type	R/W	✓	P 5-24
:DISP:TRAC:Y1:SCAL:BOTT	Y1 axis lower limit	R/W	✓	P 5-24
:DISP:TRAC:Y1:SCAL:TOP	Y1 axis upper limit	R/W	✓	P 5-24
:DISP:TRAC:Y1:SPAC	Y1 axis type	R/W	✓	P 5-24
:DISP:TRAC:Y2:SCAL:BOTT	Y2 axis lower limit	R/W	✓	P 5-25
:DISP:TRAC:Y2:SCAL:TOP	Y2 axis upper limit	R/W	✓	P 5-25
:DISP:TRAC:Y2:SPAC	Y2 axis type	R/W	✓	P 5-25

4. List of commands and command tree

[Marker commands]

Commands	Function	R/W	*RST	Details
:CALC:DATA:MARK:MODE	Marker mode	R/W	✓	P 5-15
:CALC:DATA:MARK:VAL	Marker search value	R/W	✓	P 5-15
:CALC:DATA:MARK:SEAR	Marker search	W	—	P 5-16
:CALC:DATA:MARK:SEAR:AUTO	Automatic marker search	R/W	✓	P 5-17
:CALC:DATA:MARK?	Marker value query	R	—	P 5-15
:CALC:DATA:MARK:ACT	Measurement data active target	R/W	—	P 5-15

[Trace commands]

Commands	Function	R/W	*RST	Details
:MEM:COPY:NAME	Execute data copy	W	—	P 5-26
:MEM:CLE	Execute data deletion	W	—	P 5-26

[Input commands]

Commands	Function	R/W	*RST	Details
:SENS:VOLT:AC:RANG	Input range	R/W	✓	P 5-31
:SENS:VOLT:AC:PROT	Overvoltage detection level	R/W	✓	P 5-30
:SENS:VOLT:AC:PROT:BEEP	Overvoltage detection beep	R/W	✓	P 5-30
:SENS:VOLT:AC:PROT:SWE:STOP	Stop sweep when overvoltage is detected	R/W	✓	P 5-30
:INP:GAIN	Input weight coefficient	R/W	✓	P 5-26
:INP:GAIN:INV	Input inverse status	R/W	✓	P 5-26

[Storage commands]

Commands	Function	R/W	*RST	Details
*SAV	Execute save to configuration memory	W	—	P 5-14
*RCL	Execute read from configuration memory	W	—	P 5-14
:MEM:STAT:DEL	Initialize configuration memory	W	—	P 5-27
:MEM:STAT:DEF	Configuration memory name	R/W	—	P 5-27
:DATA:STOR	Save to measurement memory	W	—	P 5-20
:DATA:REC	Read from measurement memory	W	—	P 5-19
:DATA:DEL	Measurement memory initialization	W	—	P 5-19
:DATA:STAT:DEF	Measurement memory name	R/W	—	P 5-20
:HCOP:DATA?	Get hard copy data	R	—	P 5-25

[Calibration commands]

Commands	Function	R/W	*RST	Details
:SENS:CORR:COLL	Calibration execution	W	—	P 5-29
:SENS:CORR:EQU	Equalization mode	R/W	✓	P 5-29

[Other commands]

Commands	Function	R/W	*RST	Details
:SYST:BEEP	Beep mode	R/W	—	P 5-40
:SYST:DATE	Current year, month and date	R/W	—	P 5-40
:SYST:TIME	Current hour, minutes, seconds	R/W	—	P 5-41
*RST	Initialize configuration	W	—	P 5-14
:DISP:BRIG	LCD brightness	R/W	—	P 5-20
*IDN?	Instrument-specific information query	R	—	P 5-14

4. List of commands and command tree

[Status system commands]

Commands	Function	R/W	*RST	Details
*CLS	Clear status register and error queue	W	—	P 5-13
*ESE	Standard event status enable register	R/W	—	P 5-13
*ESR?	Query standard event status register	R	—	P 5-13
*SRE	Service request register enable	R/W	—	P 5-13
*STB?	Query status byte register	R	—	P 5-13
:STAT:OPER:COND?	Query operation status condition register	R	—	P 5-39
:STAT:OPER:ENAB	Enable operation status event register	R/W	—	P 5-39
:STAT:OPER?	Query operation status event register	R	—	P 5-39
:STAT:OPER:NTR	Operation status negative transition filter	R/W	—	P 5-40
:STAT:OPER:PTR	Operation status positive transition filter	R/W	—	P 5-40
:SYST:ERR?	Query error message	R	—	P 5-41

[System commands]

Commands	Function	R/W	*RST	Details
*TST?	Query self-diagnosis results (normally returns 0)	R	—	P 5-14
*OPC	Notification that all previous commands have ended	R/W	—	P 5-14
*WAI	Waits for pending commands and queries to complete	W	—	P 5-14
:SYST:LOC	Switch to local mode [†]	W	—	P 5-41
:SYST:REM	Switch to remote mode [†]	W	—	P 5-41
:SYST:RWL	Switch to LLO mode [†]	W	—	P 5-41

[†] Used only for RS232 and LAN

4.2 Command tree

The subsystem command tree for the FRA51602 is shown below.

The brackets ([]) in the tree indicate optional keywords and the vertical bar (|) separates multiple keywords from which a selection can be made.

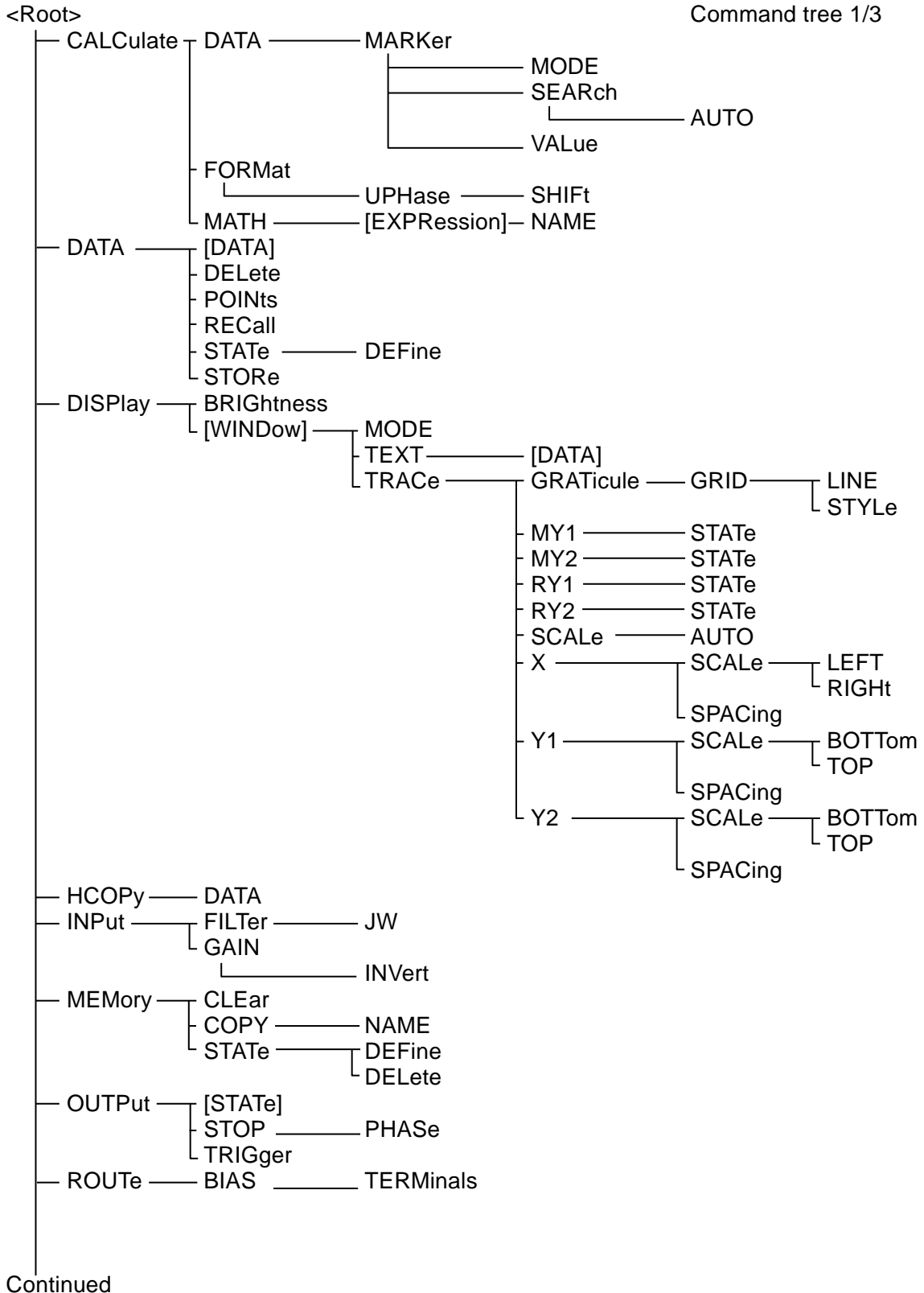

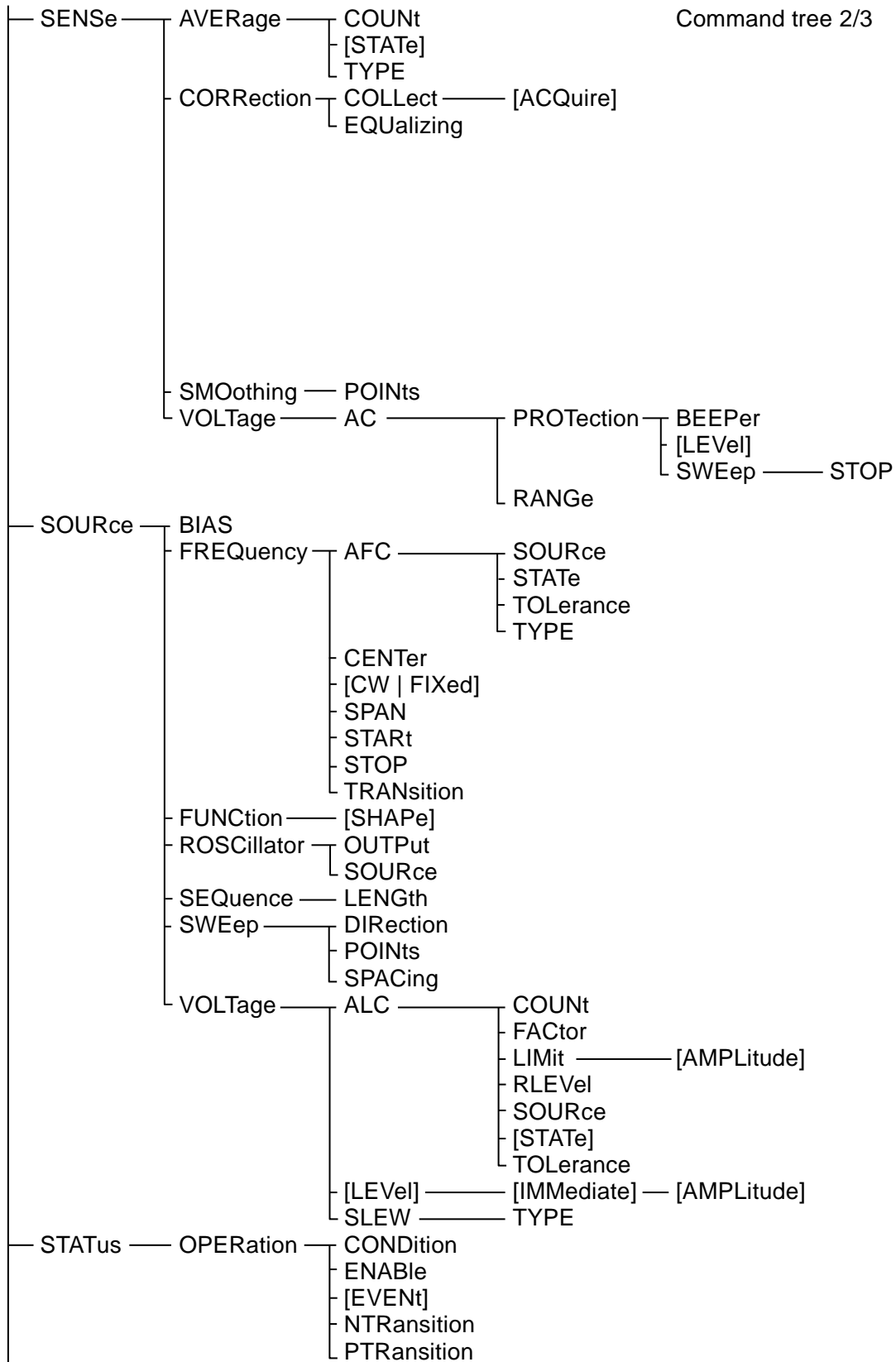

Continued

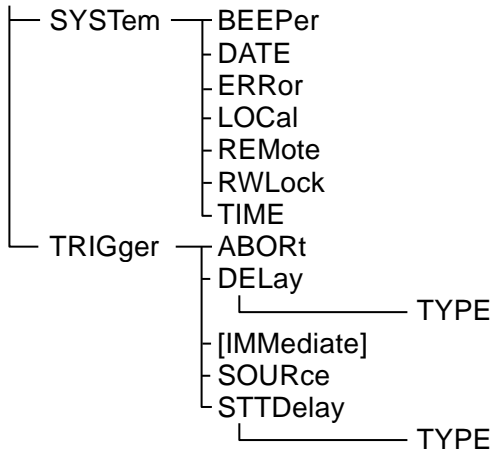

Command tree 3/3

5. Commands

5.1 Overview.....	5-2
5.2 Sequential commands	5-12
5.3 Command details.....	5-13

5.1 Overview

The FRA51602 commands comply with IEEE488.2

5.1.1 Notation

For convenience in description, the following notation is used in this document.

< > Parameters or parameter formats are enclosed in angle brackets (< >).

[] Brackets are used to enclose options, which may be omitted.

{abc|xyz}

The vertical bar (|) indicates that either “abc” or “xyz” can be used.

[abc|xyz]

Here, the brackets indicate that the choice between “abc” and “xyz” is optional and it is possible to not use either.

Uppercase and lowercase letters

Keywords that are written in uppercase and lowercase letters are long-form expressions; keywords that are written in uppercase letters are short-form expressions.

5.1.2 Command types

The FRA51602 program messages consist of common commands and subsystem commands. Here, the command formats in the subsystem command tree are explained.

5.1.2.1 Common commands

The common commands are for control of the general instrument functions. The command syntax is illustrated in Figure 5-1.

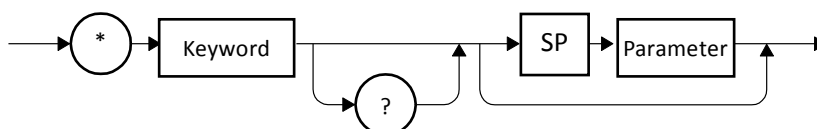

Figure 5-1 Common command syntax

The keywords in Figure 5-1 are composed of three alphabetic characters. In this example, SP represents a space (ASCII code 32).

5.1.2.2 Subsystem commands

The subsystem commands are for executing specific instrument functions. They consist of a root keyword, one or more lower-level keywords, parameters, and a suffix.

Examples of a command and a query are shown below.

```
:OUTPut:STATe ON
```

```
:OUTPut:STATe?
```

OUTPut is a root-level keyword that is concatenated with a second-level keyword. ON is a parameter.

5.1.2.3 Subsystem command syntax

The subsystem command syntax is illustrated in Figure 5-2.

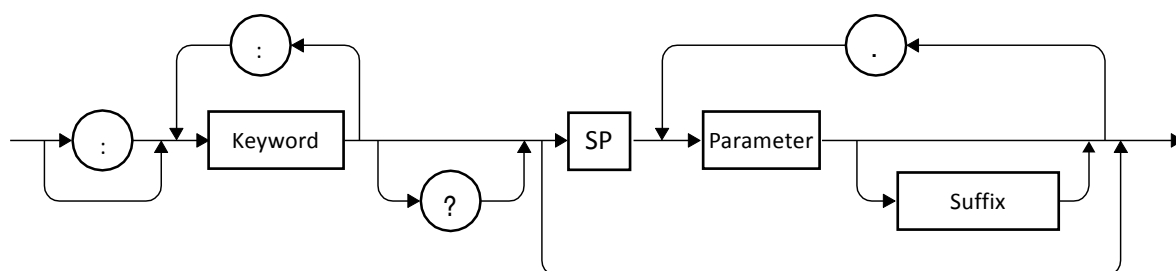

Figure 5-2 Subsystem command syntax

(A) Keywords

The keyword in Figure 5-2 is a text string of up to 12 characters that begins with a letter of the alphabet. The remaining characters can be uppercase or lowercase alphabetic characters, underscore characters, or numerals.

Most of the keywords shown in section 4.3, “Command details” are composed of a mixture of uppercase and lowercase characters. Here, uppercase characters indicate short-form expressions and the mixture of uppercase and lowercase characters indicates long-form keywords. For convenience and explanation, uppercase and lowercase characters are used in keywords, but in the actual commands, there is no distinction between uppercase and lowercase. Take the keyword “OUTPut” in Table 4-1 as an example.

Table 5-1 Keywords that are accepted or not accepted by the instrument (for the case of “OUTPut”)

Keyword	Explanation
OUTPUT	Can be used as the long form
OUTP	Can be used as the short form
OuTpUt	Uppercase and lowercase characters are not distinguished. This can be used as the long form.
oUtP	Uppercase and lowercase characters are not distinguished. This can be used as the short form.
OUTPU	This cannot be used, because it does not correspond to either the long form or the short form.
OUT	This cannot be used, because it does not correspond to either the long form or the short form.

(B) Keyword separator

The colons that appear in Figure 5-2 are interpreted as keyword separators. The keyword separator serves to separate upper-level keywords from lower-level keywords in the command tree.

The colon that appears at the beginning of subsystem commands is interpreted as a root specifier. The root specifier sets the current path as root.

(C) Keyword omission

For the commands shown in section 4.3, “Command details”, the keywords enclosed in square brackets ([]) can be omitted. If a keyword is omitted, the instrument treats that keyword as an optional keyword when executing the command.

Taking the :OUTPut[:STATe] command for example, either the following commands can be used.

:OUTPut:STATe

:OUTPut

(D) Parameters

The parameter formats are described below.

(1) Numerical parameters (<NRf>, <NR1>, <NR2>, and <NR3>)

The numerical parameter formats include integer (<NR1>), real number (floating-point) (<NR2>), and real number (exponent) (<NR3>). <NRf> is a generic expression that includes <NR1>, <NR2>, and <NR3>. The syntax for numerical parameters is illustrated below.

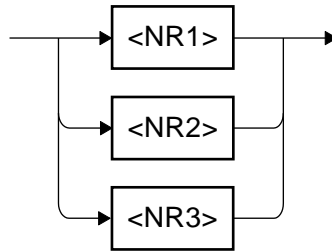

Figure 5-3 Numerical parameter syntax (<NRf>)

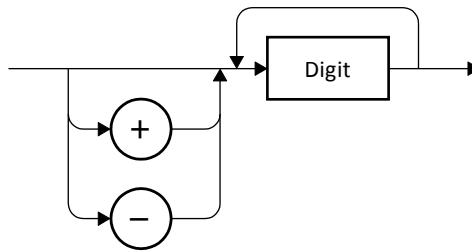

Figure 5-4 Numerical parameter syntax (<NR1>)

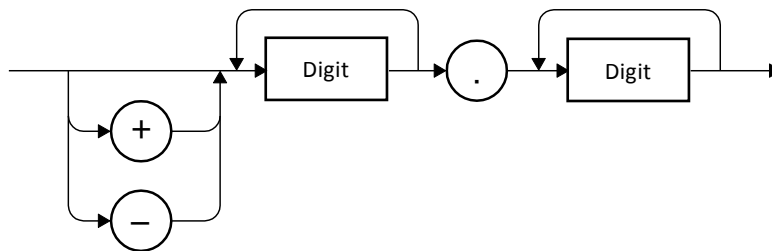

Figure 5-5 Numerical parameter syntax (<NR2>)

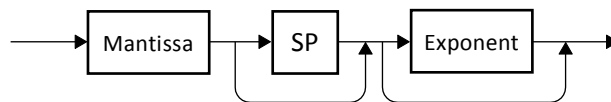

Figure 5-6 Numerical parameter syntax (<NR3>)

The syntax for the mantissa and the exponent of Figure 5-6 is illustrated below.

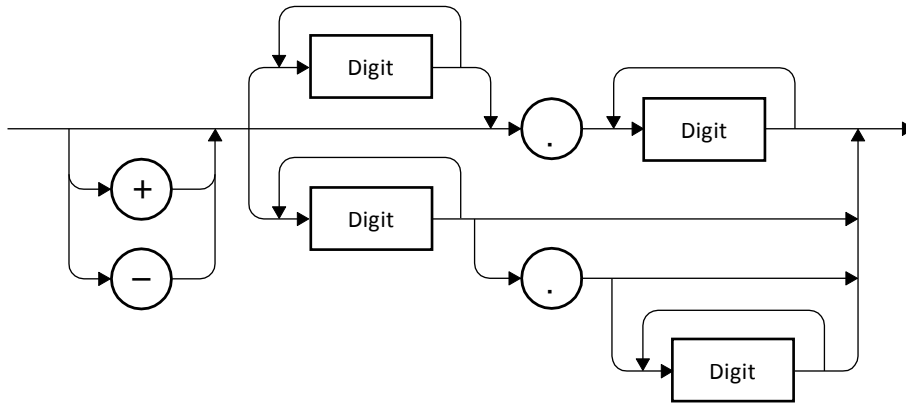

Figure 5-7 Mantissa syntax

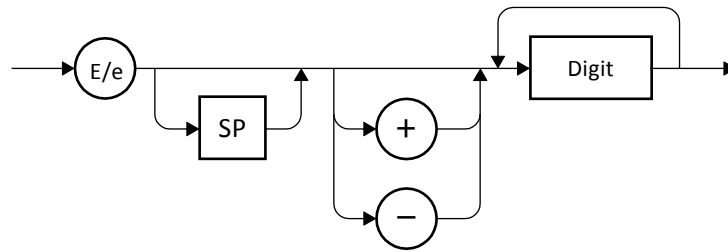

Figure 5-8 Exponent syntax

(2) Discrete parameters (<DISC>)

The syntax for discrete parameters is illustrated below.

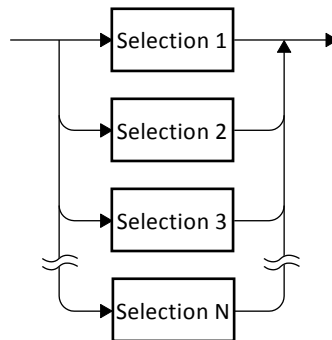

Figure 5-9 Discrete parameter syntax (<DISC>)

(3) Boolean parameters (<BOL>)

The syntax for Boolean parameters is illustrated below.

The Boolean parameter value of 0 is interpreted as “false” (OFF) and all other values are interpreted as “true” (ON).

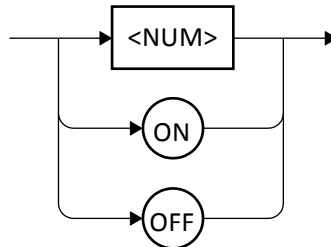

Figure 5-10 Boolean parameter syntax (<BOL>)

(4) Text string parameters (<STR>)

The syntax for text string parameters is illustrated below.

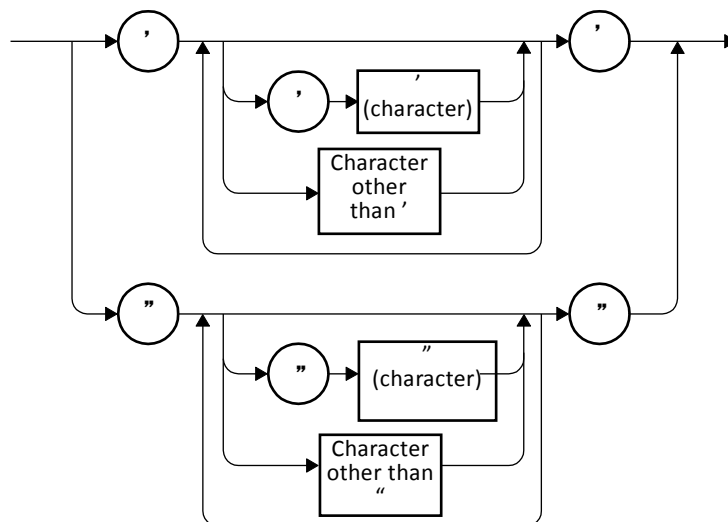

Figure 5-11 Text string parameters (<STR>)

(5) Block parameters (<BLK>)

The syntax for block parameters is illustrated below.

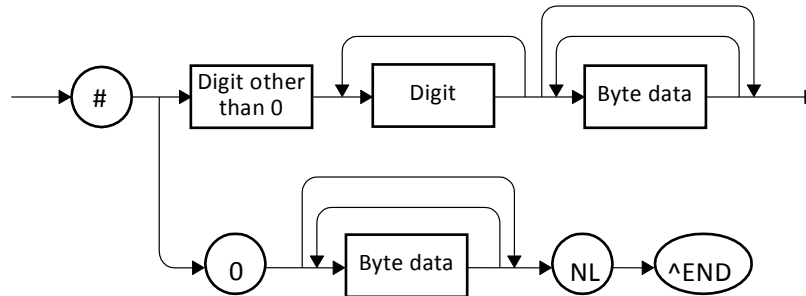

Figure 5-12 Block parameter syntax (<BLK>)

In the above diagram, NL is the new line character (ASCII code 10) and ^END is the final byte assertion (EOI).

(E) Parameter separator

The parameter separator is used between two parameters when two or more parameters are used in a command.

(F) Query parameters

Query parameters are specified after the “?” of a query.

(G) Suffixes

In some commands, it is possible to set a value by specifying an SI prefix and unit. The syntax for suffixes is illustrated below.

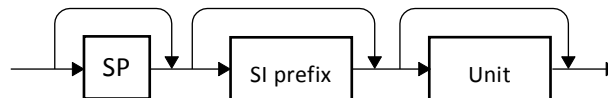

Figure 5-13 Suffix syntax

5.1.2.4 Program message syntax

The controller can send a combination of two or more common commands and subsystem commands to the instrument in a single program message. The program message syntax is illustrated below.

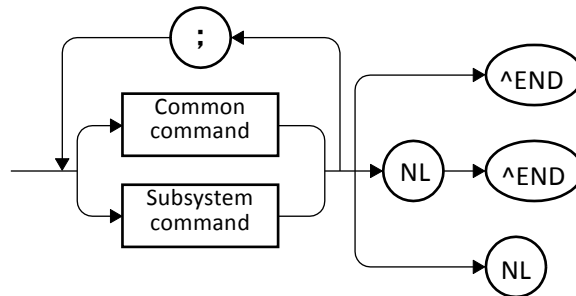

Figure 5-14 Program message syntax

Commands are separated by semicolons.

5.1.2.5 Response message syntax

Response messages are used by the instrument to send data in response to a query.

(A) Response message syntax

The syntax for response messages is illustrated in Fig. 4-15.

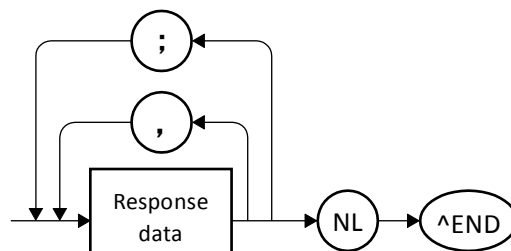

Figure 5-15 Response message syntax

In response messages, commas and semicolons are used as separators. When multiple values are returned for a single command, the data items are delineated by commas. In a response message for a single program message that contains multiple queries, on the other hand, the data that is returned for those respective queries is delineated by semicolons.

(B) Response message data

The response message data types are described below.

(1) Numerical response data (<NR1>, <NR2>, and <NR3>)

The syntax for numerical response data is illustrated below.

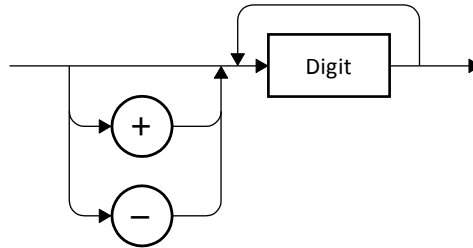

Figure 5-16 Integer response data syntax (<NR1>)

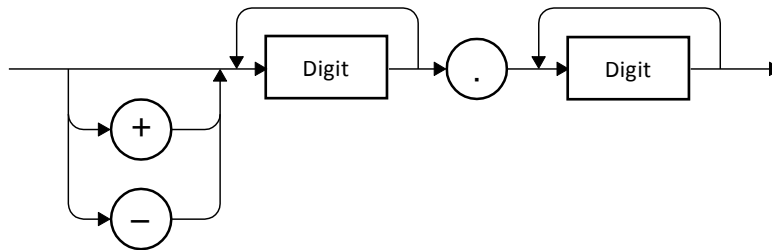

Figure 5-17 NR2 numerical response data syntax (<NR2>)

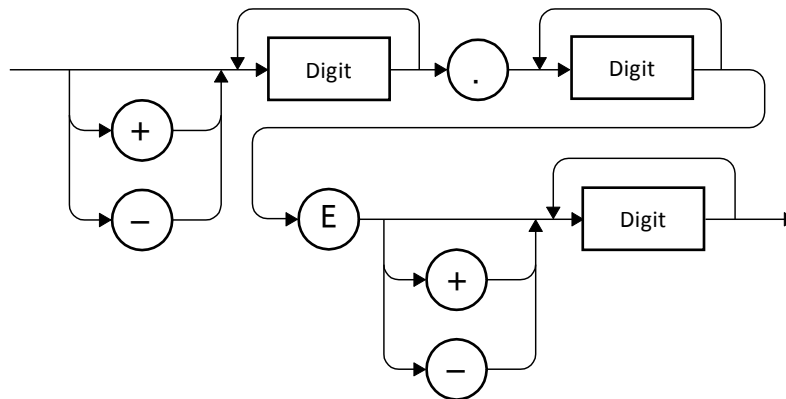

Figure 5-18 NR3 numerical response data syntax (<NR3>)

(2) Discrete response data (<DISC>)

The syntax for discrete response data is illustrated below.

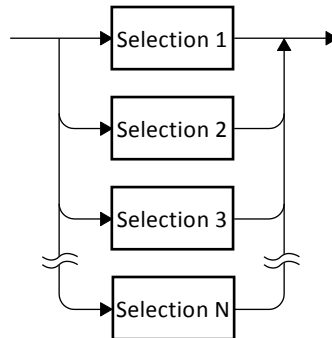

Figure 5-19 Discrete response data syntax (<DISC>)

(3) Numerical Boolean response data (<NBOL>)

The syntax for numerical Boolean response data is illustrated below.

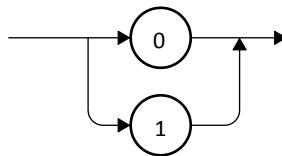

Figure 5-20 Numerical Boolean response data syntax (<NBOL>)

(4) Text string response data (<STR>)

The syntax for text string response data is illustrated below.

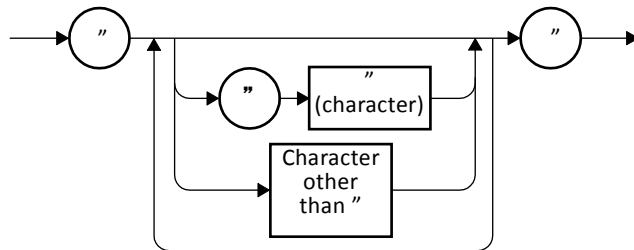

Figure 5-21 Text string response data syntax (<STR>)

(5) Defined-length arbitrary block response data (<DBLK>)

The syntax for defined-length arbitrary block response data is illustrated in Fig. 4-22.

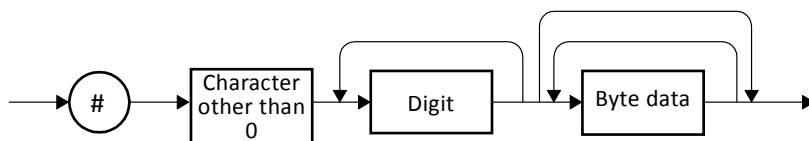

Figure 5-22 Defined-length arbitrary block response data syntax (<DBLK>)

5.2 Sequential commands

The FRA51602 commands are all sequential commands. When execution of the command is completed, the next command is executed. There are no overlapping commands.

5.3 Command details

Each command is explained in detail below.

Supplement: There is the expression “6 places (1 f(10⁻¹⁵) for <1 n(10⁻⁹)” for the resolution in the tables, but this indicates that there are normally 6 significant digits and that 1 f(10⁻¹⁵) in the case of a setting value less than 1 n(10⁻⁹).

5.3.1 *CLS

Explanation	Clears the event register and error queue	
Comments	Targets for the clear operation: Standard event status register Operation event status register Error queue	

5.3.2 *ESE <value>

*ESE?

Explanation	Sets and queries the standard event status enable register	
Parameters	<value>	<NR1> Standard event status enable register Range: 0 to 255 Resolution: 1 Default: 0
Response format	<NR1>	
Comments	Initialized when the power is turned off. Not initialized by *RST.	

5.3.3 *ESR?

Explanation	Queries the standard event status register	
Response format	<NR1>	
Comments	—	

5.3.4 *SRE <value>

*SRE?

Explanation	Sets and queries the service request enable register	
Parameters	<value>	<NR1> Service request enable register Range: 0 to 255 Resolution: 1 Default: 0
Response format	<NR1>	
Comments	Initialized when the power is turned off. Not initialized by *RST.	

5.3.5 *STB?

Explanation	Queries the status byte register	
Response format	<NR1>	
Comments	—	

5.3.6 *IDN?

Explanation	Queries the instrument identification information	
Response format	<corporation>,<model>,<serial>,<ver>	
	<corporation>	Company name (NF Corporation)
	<model>	Model name (FRA51602)
	<serial>	Serial number
	<ver>	Firmware version
Comments	NF Corporation, FRA51602, 1234567, Ver1.00	

5.3.7 *RST

Explanation	Initializes the configuration settings
Comments	—

5.3.8 *TST?

Explanation	Queries the self-diagnostic test results
Response format	<NR1>
Comments	Always, 0 is returned.

5.3.9 *OPC

*OPC?

Explanation	*OPC: Sets the OPC bit to 1 when all of the previous commands have completed *OPC?: Sets 1 to the output buffer when all the previous commands have completed
Response format	<NR1>
Comments	—

5.3.10 *RCL <value>

Explanation	Executes a read from the configuration memory	
Parameters	<value>	<NR1> Configuration memory number
		Range: 1 to 20 Resolution: 1
Comments	—	

5.3.11 *SAV <value>

Explanation	Executes a save to the configuration memory	
Parameters	<value>	<NR1> Configuration memory number
		Range: 1 to 20 Resolution: 1
Comments	—	

5.3.12 *WAI

Explanation	Standby for end of overlapping command execution
Comments	There are no overlapping commands for the FRA51602.

5.3.13 :CALCulate:DATA:MARKer? <param>

Explanation	Reads a marker value		
Query Parameters	<param>	<DISC>	Query target
			MAIN
	DELTA	Queries the delta marker value	
Response format	When the x axis is frequency <FREQdata>,<Y1data>,<Y2data>		
	When the x axis is not frequency <FREQdata>,<Xdata>,<Y1data>		
	<FREQdata>	<NR2>	
	<Xdata>	<NR3>	
	<Y1data>	<NR3>	
	<Y2data>	<NR3>	
Comments	<ul style="list-style-type: none"> The data format accords with the settings of each axis data in the graph configuration. If there is no valid measurement data, such as when there is no measurement, "NaN" (not a number) is returned. During a sweep measurement, the current measurement value is returned. After a sweep measurement, the data for the position of the specified marker is returned, regardless of the marker display status. For the delta marker, the difference with the main marker is returned. 		

5.3.14 :CALCulate:DATA:MARKer:ACTive <param>,<seq>
:CALCulate:DATA:MARKer:ACTive?

Explanation	Sets and queries the measurement data active target		
Parameters	<param>	<DISC>	Active target
			MEAS
	REF	Only the MAIN marker is displayed.	
	<seq>	<NR1>	Sequence number Range: 1 to 20 Resolution: 1
Response format	<param>,<seq>		
	<param>	MEAS REF	
	<seq>	<NR1>	Sequence number: 0 to 20
Comments	<ul style="list-style-type: none"> For setting <ul style="list-style-type: none"> For data that is not a sequence, <seq> is disregarded. For sequence data, absence of data for the specified sequence number produces an error. If marker display is disabled, or if measurement data for which display is disabled is made active, an error results. For query <ul style="list-style-type: none"> For data that is not a sequence,<seq> returns 0. If marker display is disabled or if measurement data display is disabled, and error results. 		

5.3.15 :CALCulate:DATA:MARKer:MODE <mode>
:CALCulate:DATA:MARKer:MODE?

Explanation	Sets and queries the marker mode.			
Parameters	<mode>	<DISC>	Marker mode	
			NONE	No marker
			MAIN	Only the main marker is displayed.
			DELTA	The main and delta markers are displayed.
			*RST value: MAIN	
Response format	NONE MAIN DELT			
Comments	—			

5.3.16 :CALCulate:DATA:MARKer:SEARch <param>

Explanation	Executes a marker search		
Parameters	<param>	<DISC>	Marker search content
			XMAX X Max
			XMIN X Min
			XPEak X Peak
			XBOTtom X Bottom
			NXPEak Next X Peak
			NXBOTtom Next X Bottom
			PXPEak Previous X Peak
			PXBOTtom Previous X Bottom
			X X
			NX Next X
			PX Previous X
			DX Δ X
			NDX Next Δ X
			PDX Previous Δ X
			Y1MAx Y1 Max
			Y1MIn Y1 Min
			Y1PEak Y1 Peak
			Y1BOTtom Y1 Bottom
			NY1Peak Next Y1 Peak
			NY1Bottom Next Y1 Bottom
			PY1Peak Previous Y1 Peak
			PY1Bottom Previous Y1 Bottom
			Y1 Y1
			NY1 Next Y1
			PY1 Previous Y1
			DY1 Δ Y1
			NDY1 Next Δ Y1
			PDY1 Previous Δ Y1
			Y2MAx Y2 Max
			Y2MIn Y2 Min
			Y2PEak Y2 Peak
			Y2BOTtom Y2 Bottom
			NY2Peak Next Y2 Peak
			NY2Bottom Next Y2 Bottom
			PY2Peak Previous Y2 Peak
			PY2Bottom Previous Y2 Bottom
			Y2 Y2
			NY2 Next Y2
			PY2 Previous Y2
			DY2 Δ Y2
			NDY2 Next Δ Y2
			PDY2 Previous Δ Y2
Comments	—		

5.3.17 :CALCulate:DATA:MARKer:SEARch:AUTO <param>

:CALCulate:DATA:MARKer:SEARch:AUTO?

Explanation	Sets and queries automatic marker search			
Parameters	<param>	<DISC>	Marker search content	
			OFF	Turns the automatic marker search function off.
			XMAX	X Max
			XMIN	X Min
			XPEAk	X Peak
			XBOTtom	X Bottom
			X	X
			DX	∠X
			Y1MAx	Y1 Max
			Y1MIn	Y1 Min
			Y1PEAk	Y1 Peak
			Y1BOttom	Y1 Bottom
			Y1	Y1
			DY1	∠Y1
			Y2MAx	Y2 Max
			Y2MIn	Y2 Min
			Y2PEAk	Y2 Peak
Y2BOttom	Y2 Bottom			
Y2	Y2			
DY2	∠Y2			
			*RST value: OFF	
Response format	OFF XMAX XMIN XPEA XBOT X DX Y1MA Y1MI Y1PE Y1BO Y1 DY1 Y2MA Y2MI Y2PE Y2BO Y2 DY2			
Comments	—			

5.3.18 :CALCulate:DATA:MARKer:VALue <param>,<value>

:CALCulate:DATA:MARKer:VALue? <param>

Explanation	Sets and queries the marker search value				
Parameters	<param>	<DISC>	Setting target		
			X	Sets the X marker search value	
			Y1	Sets the Y1 marker search value	
			Y2	Sets the Y2 marker search value	
			DX	Sets the ∠X marker search value	
			DY1	Sets the ∠Y1 marker search value	
			DY2	Sets the ∠Y2 marker search value	
			<value>	<NRf>	Marker search value
					Range:-1 000 000 000 000.000 00 to 1 000 000 000 000.000 00 (-1T to 1T (10 ¹²))
					Resolution: 6 places (1 f(10 ⁻¹⁵) for <1 n(10 ⁻⁹))
		*RST value: 1.0			
Query parameters	<param>	<DISC>	Query target		
			X	Queries the X marker search value	
			Y1	Queries the Y1 marker search value	
			Y2	Queries the Y2 marker search value	
			DX	Queries the ∠X marker search value	
			DY1	Queries the ∠Y1 marker search value	
			DY2	Queries the ∠Y2 marker search value	
Response format	<NR3>				
Comments	—				

5.3.19 :CALCulate:FORMat <param1>,<param2>,<param3>

:CALCulate:FORMat?

Explanation	Sets and queries the X, Y1, and Y2 parameters			
Parameters	<param1>	<DISC>	X axis data	
			FREQuency	SWEEP (frequency)
			PHASe	θ (phase $\pm 180^\circ$)
			PPHase	θ (phase 0° to $+360^\circ$)
			MPHase	θ (phase -360° to 0°)
			UPHase	θ (phase UNWRAP)
			REAL	a (real part)
	*RST value: FREQ			
	<param2>	<DISC>	Y1 axis data	
			MLINear	R (gain)
MLOGarithmic			dBR (gain)	
REAL			a (real part)	
IMAGInay			b (imaginary part)	
*RST value: MLOG				
<param3>	<DISC>	Y2 axis data		
		PHASe	θ (phase $\pm 180^\circ$)	
		PPHase	θ (phase 0° to $+360^\circ$)	
		MPHase	θ (phase -360° to 0°)	
		UPHase	θ (phase UNWRAP)	
		IMAGInary	b (imaginary part)	
		GDELay	GD (group delay)	
		NONE	None	
*RST value: PHAS				
Response format	<param1>,<param2>,<param3>			
	<param1>	FREQ PHAS PPH MPH UPH REAL		
	<param2>	MLIN MLOG REAL IMAG		
	<param3>	PHAS PPH MPH UPH IMAG GDEL NONE		
Comments	The display unit and phase range are also set according to the content of X-Y1-Y2. Thus, if the combination of X-Y1-Y2 is not consistent with valid combination for the instrument, an error results.			

5.3.20 :CALCulate:FORMat:UPHase:SHIFt <value>

Explanation	Executes a phase shift (shift value) = $360 \times \text{<value>}$		
Parameters	<value>	<NR1>	Add value
			Range: -1 or 1
Comments	The only valid settings are -1 and 1. The value 0 is rounded to -1.		

5.3.21 :CALCulate:MATH[:EXPReSSion]:NAME <mode>

:CALCulate:MATH[:EXPReSSion]:NAME?

Explanation	Sets and queries the analysis mode			
Parameters	<mode>	<DISC>	Analysis mode	
			CH1Bych2	CH1/CH2
			CH2Bych1	CH2/CH1
			CH1	CH1
			CH2	CH2
			*RST value: CH1B	
Response format	CH1B CH2B CH1 CH2			
Comments	The short forms for "CH1Bych2" and "CH2Bych1" are "CH1B" and "CH2B".			

5.3.22 :DATA[:DATA]? <param>[,<start>,<num>]

Explanation	Queries the sweep measurement data			
Parameters	<param>	<DISC>	Query targets	
			MEAS	Get MEAS data
			REF	Get REF data
			SPOT	Get SPOT measurement data
<start>	<NR1>	Data retrieval starting point Range: 0 to 20000 Resolution: 1		
<num>	<NR1>	Number of data points to get Range: 1 to 20001 Resolution: 1		
Response format	<ul style="list-style-type: none"> • Sweep measurement data <ul style="list-style-type: none"> When the x axis is frequency <FREQdata[start>,<Y1data[start>,<Y2data[start>,<FREQdata[start+1>], ... , <FREQdata[start + num>,<Y1data[start + num>,<Y2data[start + num> When the x axis is not frequency <FREQdata[start>,<Xdata[start>,<Y1data[start>,<FREQdata[start+1>], ... , <FREQdata[start + num>,<Xdata[start + num>,<Y1data[start + num> • SPOT measurement data <ul style="list-style-type: none"> When the x axis is frequency <FREQdata>,<Y1data>,<Y2data> When the x axis is not frequency <FREQdata>,<Xdata>,<Y1data> 			
	<FREQdata>	<NR2>	Frequency data	
	<Xdata>	<NR3>	X axis data (x axis is not frequency)	
	<Y1data>	<NR3>	Y1 axis data	
	<Y2data>	<NR3>	Y2 axis data	
Comments	<ul style="list-style-type: none"> • The data format accords with the settings of each axis data in the graph configuration. • If there is no valid measurement data, such as when there is no measurement, "NaN" (not a number) is returned. When measurement has been performed, the measurement data is returned at the end. • When <param> is SPOT, <start> and <num> must be omitted. • If "<start> + <num>" exceeds 20001, an error results. 			

5.3.23 :DATA:DELeTe <memory>

Explanation	Initializes the measurement memory		
Parameters	<memory>	<NR1>	Measurement memory number to be initialized
			Range: 1 to 20 Resolution: 1
Comments	—		

5.3.24 :DATA:POINtS? <param>

Explanation	Queries the number of sweep measurement data points			
Query parameters	<param>	<DISC>	Query targets	
			MEAS	Get the number of MEAS data measurement data points
			REF	Get the number of REF data measurement data points
Response format	<NR1>			
Comments	—			

5.3.25 :DATA:RECall <memory>,<dist>

Explanation	Executes a read from measurement memory		
Parameters	<memory>	<NR1>	Measurement memory number to read
			Range: 1 to 20 Resolution: 1
	<dist>	<DISC>	Destination for the data read
			MEAS
REF	Reference data		
Comments	—		

5.3.26 :DATA:STATe:DEFine “<name>”, <memory>

:DATA:STATe:DEFine? <memory>

Explanation	Sets and queries the measurement memory name		
Parameters	“<name>”	<STR>	Memory name
			Default: (empty)
	<memory>	<NR1>	Measurement memory number
			Range: 1 to 20 Resolution: 1
Query parameters	<memory>	<NR1>	Measurement memory number
			Range: 1 to 20 Resolution: 1
Response format	<STR>		
Comments	—		

5.3.27 :DATA:STORe <memory>,<src>

Explanation	Executes a save to measurement memory		
Parameters	<memory>	<NR1>	Measurement memory number that is the save destination
			Range: 1 to 20 Resolution: 1
	<src>	<DISC>	Data to be saved
			MEAS
REF	Reference data		
Comments	—		

5.3.28 :DISPlay:BRIGhtness <value>

:DISPlay:BRIGhtness?

Explanation	Sets and queries the LCD brightness		
Parameters	<value>	<NR1>	LCD brightness
			Range: 0 to 100 Resolution: 1 Default: 50
Response format	<NR1>		
Comments	—		

5.3.29 :DISPlay[:WINDow]:MODE <mode>

:DISPlay[:WINDow]:MODE?

Explanation	Sets and queries the graph display type			
Parameters	<mode>	<DISC>	Graph display type	
			SINGLE	Single display
			SPLit	Split display
			*RST value: SING	
Response format	SING SPL			
Comments	—			

5.3.30 :DISPlay[:WINDow]:TEXT[:DATA] “<title>”

:DISPlay[:WINDow]:TEXT[:DATA]?

Explanation	Sets and queries the graph title		
Parameters	“<title>”	<STR>	Graph title
			*RST value: (empty)
Response format	<STR>		
Comments	—		

5.3.31 :DISPlay[:WINDow]:TRACe:GRATICule:GRID:LINE <param>

:DISPlay[:WINDow]:TRACe:GRATICule:GRID:LINE?

Explanation	Sets and queries the grid line type			
Parameters	<param>	<DISC>	Grid line type	
			SOLid	Solid line
			BROKEn	Broken line
			*RST value: BROK	
Response format	SOL BROK			
Comments	—			

5.3.32 :DISPlay[:WINDow]:TRACe:GRATICule:GRID:STYLE <param>

:DISPlay[:WINDow]:TRACe:GRATICule:GRID:STYLE?

Explanation	Sets and queries the grid display			
Parameters	<param>	<DISC>	Grid display	
			OFF	The grid is not displayed
			X	Only X axis grid is displayed
			XY1	X and Y1 axis grids are displayed
			XY2	X and Y2 axis grids are displayed
			ALL	X, Y1, and Y2 axis grids are displayed
			*RST value: XY1	
Response format	OFF X XY1 XY2 ALL			
Comments	—			

5.3.33 :DISPlay[:WINDow]:TRACe:MY1:STATe <sw>
:DISPlay[:WINDow]:TRACe:MY1:STATe?

Explanation	Sets and queries the MEAS Y1 display status		
Parameters	<sw>	<BOL>	MEAS Y1 display status
			ON 1 MEAS Y1 is displayed
			OFF 0 MEAS Y1 is not displayed
			*RST value: 1
Response format	<NBOL>		
Comments	—		

5.3.34 :DISPlay[:WINDow]:TRACe:MY2:STATe <sw>
:DISPlay[:WINDow]:TRACe:MY2:STATe?

Explanation	Sets and queries the MEAS Y2 display status		
Parameters	<sw>	<BOL>	MEAS Y2 display status
			ON 1 MEAS Y2 is displayed
			OFF 0 MEAS Y2 is not displayed
			*RST value: 1
Response format	<NBOL>		
Comments	—		

5.3.35 :DISPlay[:WINDow]:TRACe:RY1:STATe <sw>
:DISPlay[:WINDow]:TRACe:RY1:STATe?

Explanation	Sets and queries the REF Y1 display status		
Parameters	<sw>	<BOL>	REF Y1 display status
			ON 1 REF Y1 is displayed
			OFF 0 REF Y1 is not displayed
			*RST value: 0
Response format	<NBOL>		
Comments	—		

5.3.36 :DISPlay[:WINDow]:TRACe:RY2:STATe <sw>
:DISPlay[:WINDow]:TRACe:RY2:STATe?

Explanation	Sets and queries the REF Y2 display status		
Parameters	<sw>	<BOL>	REF Y2 display status
			ON 1 REF Y2 is displayed
			OFF 0 REF Y2 is not displayed
			*RST value: 0
Response format	<NBOL>		
Comments	—		

5.3.37 :DISPlay[:WINDow]:TRACe:SCALE:AUTO <sw>
:DISPlay[:WINDow]:TRACe:SCALE:AUTO?

Explanation	Sets and queries autoscaling mode			
Parameters	<sw>	<BOL>	Autoscale switch	
			ON 1	Enables autoscaling
			OFF 0	Disables autoscaling
			*RST value: 1	
Response format	<NBOL>			
Comments	—			

5.3.38 :DISPlay[:WINDow]:TRACe:X:SCALE:LEFT <value>
:DISPlay[:WINDow]:TRACe:X:SCALE:LEFT?

Explanation	Sets and queries the x-axis lower limit			
Parameters	<value>	<NRf>	x-axis lower limit	
			<ul style="list-style-type: none"> X axis of the graph is not frequency Range: -1 000 000 000 000.000 00 to 1 000 000 000 000.000 00 (-1T to 1T (10¹²)) Resolution: 6 places (1 f(10⁻¹⁵) for <1 n(10⁻⁹)) X axis of the graph is frequency Range: 0.000 01 to 2 000 000.000 00 (10uHz to 2MHz) Resolution: 10uHz 	
			Constraints: (x-axis lower lime) < (x-axis upper limit)	
			*RST value: 10	
Response format	<NR3>			
Comments	—			

5.3.39 :DISPlay[:WINDow]:TRACe:X:SCALE:RIGHT <value>
:DISPlay[:WINDow]:TRACe:X:SCALE:RIGHT?

Explanation	Sets and queries the the x-axis upper limit			
Parameters	<value>	<NRf>	x-axis upper limit	
			<ul style="list-style-type: none"> X axis of the graph is not frequency Range: -1 000 000 000 000.000 00 to 1 000 000 000 000.000 00 (-1T to 1T (10¹²)) Resolution: 6 places (1 f(10⁻¹⁵) for <1 n(10⁻⁹)) X axis of the graph is frequency Range: 0.000 01 to 2 000 000.000 00 (10uHz to 2MHz) Resolution: 10uHz 	
			Constraints: (x-axis lower limit) < (x-axis upper limit)	
			*RST value: 100k (10 ⁵)	
Response format	<NR3>			
Comments	—			

5.3.40 :DISPlay[:WINDow]:TRACe:X:SPACing <param>
:DISPlay[:WINDow]:TRACe:X:SPACing?

Explanation	Sets and queries the x-axis type			
Parameters	<param>	<DISC>	x-axis type	
			LINear	Linear scale
			LOGarithmic	Log scale
			*RST value: LOG	
Response format	LIN LOG			
Comments	—			

5.3.41 :DISPlay[:WINDow]:TRACe:Y1:SCALE:BOTTom <value>
:DISPlay[:WINDow]:TRACe:Y1:SCALE:BOTTom?

Explanation	Sets and queries the Y1-axis lower limit			
Parameters	<value>	<NRf>	Y1 axis lower limit	
			Range: -1 000 000 000 000.000 00 to 1 000 000 000 000.000 00 (-1T to 1T (10 ¹²))	
			Constraints: (Y1 axis lower limit) < (Y1 axis upper limit)	
			Resolution: 6 places (1 f(10 ⁻¹⁵) for <1 n(10 ⁻⁹))	
			*RST value: 1	
Response format	<NR3>			
Comments	—			

5.3.42 :DISPlay[:WINDow]:TRACe:Y1:SCALE:TOP <value>
:DISPlay[:WINDow]:TRACe:Y1:SCALE:TOP?

Explanation	Sets and queries the Y1-axis upper limit			
Parameters	<value>	<NRf>	Y1 axis upper limit	
			Range: -1 000 000 000 000.000 00 to 1 000 000 000 000.000 00 (-1T to 1T (10 ¹²))	
			Constraints: (Y1 axis lower limit) < (Y1 axis upper limit)	
			Resolution: 6 places (1 f(10 ⁻¹⁵) for <1 n(10 ⁻⁹))	
			*RST value: 100k (10 ⁵)	
Response format	<NR3>			
Comments	—			

5.3.43 :DISPlay[:WINDow]:TRACe:Y1:SPACing <param>
:DISPlay[:WINDow]:TRACe:Y1:SPACing?

Explanation	Sets and queries the Y1-axis type			
Parameters	<param>	<DISC>	Y1-axis type	
			LINear	Linear scale
			LOGarithmic	Log scale
			*RST value: LIN	
Response format	LIN LOG			
Comments	—			

5.3.44 :DISPlay[:WINDow]:TRACe:Y2:SCALe:BOTTom <value>
:DISPlay[:WINDow]:TRACe:Y2:SCALe:BOTTom?

Explanation	Sets and queries the Y2-axis lower limit		
Parameters	<value>	<NRf>	Y2 axis lower limit
			Range: -1 000 000 000 000.000 00 to 1 000 000 000 000.000 00 (-1T to 1T (10 ¹²)) Constraints: (Y2 axis lower limit) < (Y2 axis upper limit) Resolution: 6 places (1 f(10 ⁻¹⁵) for <1 n(10 ⁻⁹)) *RST value: 1
Response format	<NR3>		
Comments	—		

5.3.45 :DISPlay[:WINDow]:TRACe:Y2:SCALe:TOP <value>
:DISPlay[:WINDow]:TRACe:Y2:SCALe:TOP?

Explanation	Sets and queries the Y1-axis upper limit		
Parameters	<value>	<NRf>	Y2 axis upper limit
			Range: -1 000 000 000 000.000 00 to 1 000 000 000 000.000 00 (-1T to 1T (10 ¹²)) Constraints: (Y2 axis lower limit) < (Y2 axis upper limit) Resolution: 6 places (1 f(10 ⁻¹⁵) for <1 n(10 ⁻⁹)) *RST value: 10
Response format	<NR3>		
Comments	—		

5.3.46 :DISPlay[:WINDow]:TRACe:Y2:SPACing <param>
:DISPlay[:WINDow]:TRACe:Y2:SPACing?

Explanation	Sets and queries the Y2-axis type			
Parameters	<param>	<DISC>	Y2-axis type	
			LINear	Linear scale
			LOGarithmic	Log scale
			*RST value: LIN	
Response format	LIN LOG			
Comments	—			

5.3.47 :HCOPY:DATA?

Explanation	Gets the bitmap for the current screen	
Response format	<DBLK> (#<digit><byte><data>)	
	#	Beginning of binary data
	<digit>	A number (0 or greater) that indicates the number of digits in the subsequent <byte>
	<byte>	String of numbers that indicate the number of bytes in the subsequent data
	<data>	The binary data
Comments	The <data> part of the retrieve data is extracted and saved to a file in “.bmp” format. To receive the responses to this command all at once, a buffer capacity of at least 1,920,063 bytes is required.	

5.3.48 :INPut:FILTer:JW <value>

:INPut:FILTer:JW?

Explanation	Sets and queries the differentiation processing		
Parameters	<value>	<NR1>	Differentiation
			Range: -2 to 2 (double integral, integral, none, differential, double differential) Resolution: 1 *RST value: 0
Response format	<NR1>		
Comments	—		

5.3.49 :INPut:GAIN <value1>,<value2>

:INPut:GAIN?

Explanation	Sets and queries the input weight coefficient		
Parameters	<value1>	<NRf>	CH1 input gain
			Range: 0.000 000 000 000 to 1 000 000 000 000 (0 to 1T (10 ¹²)) Resolution: 6 places (1 p(10 ⁻¹²) for <1 u(10 ⁻⁶)) *RST value: 1
	<value2>	<NRf>	CH2 input gain
			Range: 0.000 000 000 000 to 1 000 000 000 000 (0 to 1T (10 ¹²)) Resolution: 6 places (1 p(10 ⁻¹²) for <1 u(10 ⁻⁶)) *RST value: 1
Response format	<value1>,<value2>		
	<value1>	<NR3>	CH1 input gain
	<value2>	<NR3>	CH2 input gain
Comments	—		

5.3.50 :INPut:GAIN:INVert <sw>

:INPut:GAIN:INVert?

Explanation	Sets and queries the input signal phase inversion mode			
Parameters	<sw>	<BOL>	Phase inversion status	
			ON 1	Enables phase inversion
			OFF 0	Disables phase inversion
		*RST value: 0		
Response format	<NBOL>			
Comments	—			

5.3.51 :MEMory:CLEAr <obj>

Explanation	Executes data deletion			
Parameters	<obj>	<DISC>	Data to be deleted	
			MEAS	Measurement data is deleted
			REF	Reference data is deleted
Comments	—			

5.3.52 :MEMory:COpy:NAME <dist>

Explanation	Executes measurement data copying			
Parameters	<dist>	<DISC>	Copy destination	
			REF	Reference data
			EQU	Equalizing
Comments	—			

5.3.53 :MEMory:STATe:DEFine “<name>”, <memory> :MEMory:STATe:DEFine? <memory>

Explanation	Sets and queries the measurement memory name		
Parameters	“<name>”	<STR>	Memory name Default: (empty)
	<memory>	<NR1>	Configuration memory number Range: 1 to 20 Resolution: 1
Query parameters	<memory>	<NR1>	Configuration memory number Range: 1 to 20 Resolution: 1
Response format	<STR>		
Comments	—		

5.3.54 :MEMory:STATe:DELete <memory>

Explanation	Initializes the configuration memory		
Parameters	<memory>	<NR1>	Configuration memory number to be initialized Range: 1 to 20 Resolution: 1
Comments	—		

5.3.55 :OUTPut[:STATe] <param> :OUTPut[:STATe]?

Explanation	Sets and queries the output status			
Parameters	<param>	<DISC>	Output status	
			ON	Sets the AC/DC on status
			OFF	Sets the AC/DC off status
			ACoff	Sets the AC off status
			*RST value: OFF	
Response format	ON OFF AC			
Comments	ACoff is ignored if the AC/DC status is not “on”.			

5.3.56 :OUTPut:STOP:PHASe <param> :OUTPut:STOP:PHASe?

Explanation	Sets and queries the stop mode			
Parameters	<param>	<DISC>	Stop mode (oscillation stop phase)	
			SYNChronous	Sets the stop mode to 0°SYNC.
			ASYNchronous	Sets the stop mode to QUICK.
			*RST value: ASYN	
Response format	SYNC ASYN			
Comments	—			

5.3.57 :OUTPut:TRIGger <mode>

:OUTPut:TRIGger?

Explanation	Sets and queries the on/off synchronization (trigger synchronization)			
Parameters	<mode>	<DISC>	On/off synchronization (trigger synchronization)	
			ASYNchronous	Sets on/off synchronization to ASYNC. (disables trigger synchronization)
			SYNChronous	Sets on/off synchronization to SYNC. (enables trigger synchronization) (AC/DC on, AC/DC off)
			SYNChronous2	Sets on/off synchronization to SYNC. (enables trigger synchronization) (AC/DC on, AC off)
			*RST value: ASYN	
Response format	ASYN SYNC SYNC2			
Comments	—			

5.3.58 :ROUte:BIAS:TERMinals <param>

:ROUte:BIAS:TERMinals?

Explanation	Sets and queries the bias output destination			
Parameters	<param>	<DISC>	Output destination	
			FRONt	The DC component is output from the front panel OSC terminal.
			REAR	The DC component is output from the rear panel DC BIAS terminal.
				*RST value: FRONt
Response format	FRON REAR			
Comments	—			

5.3.59 :SENSe:AVERage:COUNT <value>,<param>

:SENSe:AVERage:COUNT? <param>

Explanation	Sets and queries the averaging cycle and time			
Parameters	<value>	<NRf> CYCLe	Averaging cycle setting (cycle)	
			Range: 1 to 9999	
			Resolution: 1 *RST value: 1	
	<NRf> TIMe	Averaging time setting (seconds)		
		Range: 0.000 sec to 9990 sec		
		Resolution: 3 places (1 msec for <1 sec) *RST value: 0.0 sec		
<param>	<DISC>	Setting content		
		CYCLe	Set by the averaging cycle	
		TIMe	Set by the averaging time	
Query parameters	<param>	<DISC>	Query content	
			CYCLe	Queries the averaging cycle
			TIMe	Queries the averaging time
Response format	<NR1>	The query parameter is CYCLe.		
	<NR3>	The query parameter is TIMe.		
Comments	—			

5.3.60 :SENSe:AVERAge[:STATe] <mode>

:SENSe:AVERAge[:STATe]?

Explanation	Sets and queries the averaging mode			
Parameters	<mode>	<DISC>	Averaging mode	
			FIXed	Set the averaging mode to FIX
			SHORt	Set the averaging mode to SHORT
			MEDium	Set the averaging mode to MED
			LONG	Set the averaging mode to LONG
*RST value: FIX				
Response format	FIX SHOR MED LONG			
Comments	—			

5.3.61 :SENSe:AVERAge:TYPE?

Explanation	Queries the current averaging setting type
Response format	CYCL TIM
Comments	—

5.3.62 :SENSe:CORRection:COLLect[:ACQuire]

Explanation	Executes calibration
Comments	—

5.3.63 :SENSe:CORRection:EQUalizing <sw>

:SENSe:CORRection:EQUalizing?

Explanation	Sets and queries the equalization mode			
Parameters	<sw>	<NBOL>	Equalization mode	
			ON 1	Enables equalization
			OFF 0	Disables equalization
			*RST value: 0	
Response format	<NBOL>			
Comments	—			

5.3.64 :SENSe:SMOothing:POINts <value>

:SENSe:SMOothing:POINts?

Explanation	Sets and queries the phase moving average			
Parameters	<value>	<NR1>	Phase moving average	
			Range: 2 to 200	
			Resolution: 2	
			*RST value: 10	
Response format	<NR1>			
Comments	Even only; if odd, rounded down to the next valid value			

5.3.65 :SENSe:VOLTage:AC:PROTection:BEEPer <sw>
:SENSe:VOLTage:AC:PROTection:BEEPer?

Explanation	Sets and queries the overvoltage detection beep mode			
Parameters	<sw>	<BOL>	Overvoltage detection beep	
			ON 1	Beep sounds
			OFF 0	Beep does not sound
			*RST value: 0	
Response format	<NBOL>			
Comments	—			

5.3.66 :SENSe:VOLTage:AC:PROTection[:LEVel] <value>[<unit>],<ch>
:SENSe:VOLTage:AC:PROTection[:LEVel]? <ch>

Explanation	Sets and queries the overvoltage detection level			
Parameters	<value>	<NRf>	Overvoltage detection level	
			Range: 0.000000 to 600	
			Resolution: 3 places (1 uVrms for <1 mVrms)	
	<unit>	<DISC>	Unit	
			M	<value>x10 ⁻³
			MV	<value>x10 ⁻³
	<ch>	<DISC>	Channel	
CH1			CH1 overvoltage detection level is set.	
CH2			CH2 overvoltage detection level is set.	
Query parameters	<ch>	<DISC>	Channel	
			CH1	CH1 overvoltage detection level is queried.
			CH2	CH2 overvoltage detection level is queried.
Response format	<NR3>			
Comments	—			

5.3.67 :SENSe:VOLTage:AC:PROTection:SWEep:STOP <sw>
:SENSe:VOLTage:AC:PROTection:SWEep:STOP?

Explanation	Sets and queries the sweep stop for overvoltage detection			
Parameters	<sw>	<BOL>	Sweep stop for overvoltage detection	
			ON 1	The sweep operation is stopped upon overvoltage detection.
			OFF 0	The sweep operation continues upon overvoltage detection.
			*RST value: 0	
Response format	<NBOL>			
Comments	—			

5.3.68 :SENSe:VOLTage:AC:RANGe <ch1param>,<ch2param>
:SENSe:VOLTage:AC:RANGe?

Explanation	Sets and queries the range		
Parameters	<ch1param>	<NR1>	CH1 range Range: 0 to 10 (AUTO, 600, 300, 100, 30, 10, 3, 1, 0.3, 0.1, 0.03) Resolution: 1 *RST value: 0
	<ch2param>	<NR1>	CH2 range Range: 0 to 10 (AUTO, 600, 300, 100, 30, 10, 3, 1, 0.3, 0.1, 0.03) Resolution: 1 *RST value: 0
Response format	<ch1param>,<ch2param>		
	<ch1param>	<NR1>	CH1 range
	<ch2param>	<NR1>	CH2 range
Comments	The range parameters are the values within the parentheses.		

5.3.69 :SOURce:BIAS <value>[<unit>]
:SOURce:BIAS?

Explanation	Sets and queries the DC bias value		
Parameters	<value>	<NRf>	DC bias Range: -10.00V to 10.00V Constraints: (DC bias) + (amplitude) ≤ 10.00 Resolution: 10mV *RST value: 0V
	<unit>	<DISC>	Unit M <value>×10 ⁻³ MV <value>×10 ⁻³ V <value>
Response format	<NR2>		
Comments	—		

5.3.70 :SOURce:FREQuency:AFC:SOURce <ch>
:SOURce:FREQuency:AFC:SOURce?

Explanation	Sets and queries the slow sweep reference channel			
Parameters	<ch>	<DISC>	Slow sweep reference channel	
			CH1	Sets the slow sweep reference channel to CH1.
			CH2	Sets the slow sweep reference channel to CH2.
			*RST value: CH1	
Response format	CH1 CH2			
Comments	—			

5.3.71 :SOURce:FREQuency:AFC:STATe <sw>
:SOURce:FREQuency:AFC:STATe?

Explanation	Sets and queries the slow sweep mode			
Parameters	<sw>	<BOL>	Slow sweep mode	
			ON 1	Enables slow sweep.
			OFF 0	Disables slow sweep.
			*RST value: 0	
Response format	<NBOL>			
Comments	—			

5.3.72 :SOURce:FREQuency:AFC:TOLerance <value>
:SOURce:FREQuency:AFC:TOLerance?

Explanation	Sets and queries the slow sweep permissible quantities		
Parameters	<value>	<NRf>	Slow Sweep permissible quantities
			dBR Range: 0.00 to 1000 Resolution: 3 places (0.01 dB for <10 dB) *RST value: 10dB
			R Range: 0.000000 to 600 Resolution: 3 places (1 uVrms for <1 mVrms) *RST value: 1Vrms
			θ Range: 0 to 180 Resolution: 3 places (0.01 deg for <10 deg) *RST value: 10deg
			a, b Range: 0.000000 to 600 Resolution: 3 places (1 uVrms for <1 mVrms) *RST value: 1Vrms
Response format	<NR2>	When the current monitoring parameter setting is dBR, θ	
	<NR3>	When the current monitoring parameter setting is R,a,b	
Comments	The range for slow sweep permissible quantity setting varies with the slow sweep monitoring parameters that are set.		

5.3.73 :SOURce:FREQuency:AFC:TYPE <param>
:SOURce:FREQuency:AFC:TYPE?

Explanation	Sets and queries the slow sweep monitoring parameters			
Parameters	<param>	<DISC>	Slow sweep monitoring parameters	
			MLOGarithmic	dBR
			MLINear	R
			PHASe	θ
			REAL	a
			IMAGinary	b
			*RST value: PHAS	
Response format	MLOG MLIN PHAS REAL IMAG			
Comments	—			

5.3.74 :SOURce:FREQUency:CENTer <value>[<unit>]
:SOURce:FREQUency:CENTer?

Explanation	Sets and queries the center value of the frequency sweep		
Parameters	<value>	<NRf>	Center value of the frequency sweep
			Range: 0.000 01 to 2 000 000.000 00 (10uHz to 2MHz)
			Constraints: (starting frequency) < (stopping frequency) Resolution: 0.000 01Hz
	<unit>	<DISC>	Unit
			MA <value>x10 ⁶
			K <value>x10 ³
			M <value>x10 ⁻³
			U <value>x10 ⁻⁶
			MAHZ <value>x10 ⁶
KHZ <value>x10 ³			
MHZ <value>x10 ⁻³			
UHZ <value>x10 ⁻⁶			
HZ <value>			
Response format	<NR2>		
Comments	<p>The center frequency value and span value are changed appropriately when the starting frequency and stopping frequency are changed. Conversely, starting frequency and stopping frequency are changed appropriately according to changes in the center frequency and the span.</p> <p>[Conversion equations] <Center frequency> = (<lower limit frequency> + <upper limit frequency>) / 2 = <upper limit frequency> - <lower limit frequency> <Upper limit frequency> = <center frequency> + / 2 <Lower limit frequency> = <center frequency> - / 2</p>		

5.3.75 :SOURce:FREQUency[:CW]:FIXed <value>[<unit>]
:SOURce:FREQUency[:CW]:FIXed?

Explanation	Sets and queries the spot frequency		
Parameters	<value>	<NRf>	Spot frequency
			Range: 0.000 01 to 2 000 000.000 00 (10uHz to 2MHz)
			Resolution: 0.000 01Hz *RST value: 1000.0Hz
	<unit>	<DISC>	Unit
			MA <value>x10 ⁶
			K <value>x10 ³
			M <value>x10 ⁻³
			U <value>x10 ⁻⁶
			MAHZ <value>x10 ⁶
KHZ <value>x10 ³			
MHZ <value>x10 ⁻³			
UHZ <value>x10 ⁻⁶			
HZ <value>			
Response format	<NR2>		
Comments	—		

5.3.76 :SOURce:FREQuency:SPAN <value>[<unit>]

:SOURce:FREQuency:SPAN?

Explanation	Sets and queries the frequency sweep span		
Parameters	<value>	<NRf>	Frequency sweep span
			Range: 0.000 01 to 2 000 000.000 00 (10uHz to 2MHz)
			Constraints: (sweep starting frequency) < (sweep stopping frequency) Resolution: 0.000 01Hz
	<unit>	<DISC>	Unit
			MA <value>x10 ⁶
			K <value>x10 ³
			M <value>x10 ⁻³
			U <value>x10 ⁻⁶
			MAHZ <value>x10 ⁶
KHZ <value>x10 ³			
MHZ <value>x10 ⁻³			
UHZ <value>x10 ⁻⁶			
HZ <value>			
Response format	<NR2>		
Comments	<p>The center frequency value and span value are changed appropriately when the starting frequency and stopping frequency are changed. Conversely, starting frequency and stopping frequency are changed appropriately according to changes in the center frequency and the span. [Conversion equations] <Center frequency> = (<lower limit frequency> + <upper limit frequency>) / 2 = <upper limit frequency> - <lower limit frequency> <Upper limit frequency> = <center frequency> + / 2 <Lower limit frequency> = <center frequency> - / 2</p>		

5.3.77 :SOURce:FREQuency:STARt <value>[<unit>]

:SOURce:FREQuency:STARt?

Explanation	Sets and queries the sweep lower limit frequency		
Parameters	<value>	<NRf>	Sweep lower limit frequency
			Range: 0.000 01 to 2 000 000.000 00 (10uHz to 2MHz)
			Constraints: (sweep lower limit frequency) < (sweep upper limit frequency) Resolution: 0.000 01Hz *RST value: 100 000.0Hz
	<unit>	<DISC>	Unit
			MA <value>x10 ⁶
			K <value>x10 ³
			M <value>x10 ⁻³
			U <value>x10 ⁻⁶
			MAHZ <value>x10 ⁶
KHZ <value>x10 ³			
MHZ <value>x10 ⁻³			
UHZ <value>x10 ⁻⁶			
HZ <value>			
Response format	<NR2>		
Comments	—		

5.3.78 :SOURce:FREQUency:STOP <value>[<unit>] :SOURce:FREQUency:STOP?

Explanation	Sets and queries the sweep upper limit frequency		
Parameters	<value>	<NRf>	Sweep upper limit frequency Range: 0.000 01 to 2 000 000.000 00 (10uHz to 2MHz) Constraints: (sweep lower limit frequency) < (sweep upper limit frequency) Resolution: 0.000 01Hz *RST value: 10Hz
	<unit>	<DISC>	Unit MA <value>x10 ⁶ K <value>x10 ³ M <value>x10 ⁻³ U <value>x10 ⁻⁶ MAHZ <value>x10 ⁶ KHZ <value>x10 ³ MHZ <value>x10 ⁻³ UHZ <value>x10 ⁻⁶ HZ <value>
Response format	<NR2>		
Comments	—		

5.3.79 :SOURce:FREQUency:TRANSition <mode> :SOURce:FREQUency:TRANSition?

Explanation	Sets and queries the frequency change mode			
Parameters	<mode>	<DISC>	Frequency change mode	
			SYNChronous	Sets the frequency change mode to 0°SYNC.
			ASYNchronous	Sets the frequency change mode to ASYNC.
			*RST value: ASYN	
Response format	SYNC ASYN			
Comments	—			

5.3.80 :SOURce:FUNCTion[:SHAPe] <param> :SOURce:FUNCTion[:SHAPe]?

Explanation	Sets and queries the internal oscillator waveform			
Parameters	<param>	<DISC>	Internal oscillator waveform	
			SINusoid	Sinusoidal wave
			SQUare	Square wave
			TRIangle	Triangular wave
			*RST value: SIN	
Response format	SIN SQU TRI			
Comments	—			

5.3.81 :SOURce:ROSCillator:OUTPut[:STATe] <sw>
:SOURce:ROSCillator:OUTPut[:STATe]?

Explanation	Sets and queries the 10MHz REF OUT output status			
Parameters	<sw>	<BOL>	10MHz REF OUT status	
			ON 1	10MHz REF OUT is output.
			OFF 0	10MHz REF OUT is not output.
			*RST value: 0	
Response format	<NBOL>			
Comments	—			

5.3.82 :SOURce:ROSCillator:SOURce <param>
:SOURce:ROSCillator:SOURce?

Explanation	Sets and queries the external frequency reference (10MHz REF IN)			
Parameters	<param>	<DISC>	Reference clock source (10MHz REF IN)	
			INTernal	The external reference clock is enabled.
			EXTernal	The external reference clock is disabled.
			*RST value: INT	
Response format	INT EXT			
Comments	—			

5.3.83 :SOURce:SEQUence:LENGth <value>
:SOURce:SEQUence:LENGth?

Explanation	Sets and queries the sequence sweep			
Parameters	<value>	<NR1>	Configuration memory number	
			Range: 0 to 20	
			Resolution: 1	
Response format	<NR1>			
Comments	If not OFF, the measurement conditions that are stored in the configuration memories from 1 to <value> are executed in order at the time of measurement. The value 0 represents OFF.			

5.3.84 :SOURce:SWEep:DIRection?

Explanation	Queries the sweep direction
Response format	UP DOWN SPOT
Comments	Returns the current measurement state

5.3.85 :SOURce:SWEep:POINts <value>
:SOURce:SWEep:POINts?

Explanation	Sets and queries the number of sweep points			
Parameters	<value>	<NR1>	Number of sweep points	
			Range: 3 to 20000	
			Resolution: 1	
			*RST value: 100	
Response format	<NR1>			
Comments	—			

5.3.86 :SOURce:SWEEp:SPACing <param>
:SOURce:SWEEp:SPACing?

Explanation	Sets and queries the sweep spacing			
Parameters	<param>	<DISC>	Sweep spacing	
			LINear	Linear
			LOGarithmic	Log
			*RST value: LOG	
Response format	LIN LOG			
Comments	—			

5.3.87 :SOURce:VOLTage:ALC:COUNT <value>
:SOURce:VOLTage:ALC:COUNT?

Explanation	Sets and queries the number of amplitude compression retries			
Parameters	<value>	<NR1>	Number of amplitude compression retries	
			Range: 1 to 9999	
			Resolution: 1	
			*RST value: 10	
Response format	<NR1>			
Comments	—			

5.3.88 :SOURce:VOLTage:ALC:FACTor <value>
:SOURce:VOLTage:ALC:FACTor?

Explanation	Sets and queries the amplitude compression correction factor			
Parameters	<value>	<NR1>	Amplitude compression correction factor	
			Range: 1% to 100%	
			Resolution: 1%	
			*RST value: 100%	
Response format	<NR1>			
Comments	—			

5.3.89 :SOURce:VOLTage:ALC:LIMit[:AMPLitude] <value>[<unit>]
:SOURce:VOLTage:ALC:LIMit[:AMPLitude]?

Explanation	Sets and queries the amplitude compression output limit			
Parameters	<value>	<NRf>	Amplitude compression output limit	
			Range: 0.001Vpk to 10.0Vpk	
			Resolution: 3 places	
	<unit>	<DISC>	Unit	
			M	<value>x10 ⁻³
			MV	<value>x10 ⁻³
V	<value>			
Response format	<NR2>			
Comments	—			

5.3.90 :SOURce:VOLTage:ALC:RLEVel <value>[<unit>]
:SOURce:VOLTage:ALC:RLEVel?

Explanation	Sets and queries the amplitude compression reference level		
Parameters	<value>	<NRf>	Amplitude compression reference level
			Range: 0.00100Vrms to 600Vrms Resolution: 3 places *RST value: 1Vrms
	<unit>	<DISC>	Unit
			M
MV			<value>x10 ⁻³
		V	<value>
Response format	<NR2>		
Comments	—		

5.3.91 :SOURce:VOLTage:ALC:SOURce <ch>
:SOURce:VOLTage:ALC:SOURce?

Explanation	Sets and queries the amplitude compression reference channel			
Parameters	<ch>	<DISC>	Amplitude compression reference channel	
			CH1	Sets the reference channel to CH1.
			CH2	Sets the reference channel to CH2.
			*RST value: CH1	
Response format	CH1 CH2			
Comments	—			

5.3.92 :SOURce:VOLTage:ALC[:STATe] <sw>
:SOURce:VOLTage:ALC[:STATe]?

Explanation	Sets and queries the amplitude compression status			
Parameters	<sw>	<BOL>	Amplitude compression status	
			ON 1	Amplitude compression is enabled.
			OFF 0	Amplitude compression is disabled.
			*RST value: 0	
Response format	<NBOL>			
Comments	—			

5.3.93 :SOURce:VOLTage:ALC:TOLerance <value>
:SOURce:VOLTage:ALC:TOLerance?

Explanation	Sets and queries the amplitude compression permissible error			
Parameters	<value>	<NR1>	Amplitude compression permissible error	
			Range: 1% to 100%	
			Resolution: 1%	
			*RST value: 10%	
Response format	<NR1>			
Comments	—			

5.3.94 :SOURce:VOLTage[:LEVel][:IMMediate][:AMPLitude] <value>
:SOURce:VOLTage[:LEVel][:IMMediate][:AMPLitude]?

Explanation	Sets and queries the internal oscillator amplitude		
Parameters	<value>	<NRf>	Internal oscillator amplitude
			Range: 0.000 00Vpk to 10.0Vpk Constraints: (DC bias) + (amplitude) \leq 10.00 Resolution: 3 places (10 uVpk for <10 mVpk) *RST value: 1Vpk
	<unit>	<DISC>	Unit
			M
MV			<value>x10 ⁻³
	V	<value>	
Response format	<NR3>		
Comments	—		

5.3.95 :SOURce:VOLTage:SLEW:TYPE <param>
:SOURce:VOLTage:SLEW:TYPE?

Explanation	Sets and queries the on/off mode			
Parameters	<param>	<DISC>	On/off mode type	
			QUICK	Sets the on/off mode to QUICK.
			SLOW	Sets the on/off mode to SLOW.
			*RST value: QUIC	
Response format	QUIC SLOW			
Comments	—			

5.3.96 :STATus:OPERation:CONDition?

Explanation	Queries the operation status condition register		
Response format	<NR1>		
Comments	—		

5.3.97 :STATus:OPERation:ENABLE <value>
:STATus:OPERation:ENABLE?

Explanation	Sets and queries the operation status event enable register		
Parameters	<value>	<NR1>	Operation status event enable register
			Range: 0 to 65535 Resolution: 1 Default: 0
Response format	<NR1>		
Comments	Initialized when the power is turned off. Not initialized by *RST.		

5.3.98 :STATus:OPERation[:EVENT]?

Explanation	Queries the operation status event register		
Response format	<NR1>		
Comments	—		

5.3.99 :STATus:OPERation:NTRansition <value>

:STATus:OPERation:NTRansition?

Explanation	Sets and queries the negative operation status transition filter		
Parameters	<value>	<NR1>	Negative operation status transition filter
			Range: 0 to 65535 Resolution: 1 Default: 0
Response format	<NR1>		
Comments	Initialized when the power is turned off. Not initialized by *RST.		

5.3.100 :STATus:OPERation:PTRansition <value>

:STATus:OPERation:PTRansition?

Explanation	Sets and queries the positive operation status transition filter		
Parameters	<value>	<NR1>	Positive operation status transition filter
			Range: 0 to 65535 Resolution: 1 Default: 0
Response format	<NR1>		
Comments	Initialized when the power is turned off. Not initialized by *RST.		

5.3.101 :SYSTem:BEEPer <sw>

:SYSTem:BEEPer?

Explanation	Sets and queries the beep sound status			
Parameters	<sw>	<BOL>	Beep sound status	
			ON 1	Enables the beep sound.
			OFF 0	Disables the beep sound.
			Default: 1	
Response format	<NBOL>			
Comments	—			

5.3.102 :SYSTem:DATE <year>,<month>,<day>

:SYSTem:DATE?

Explanation	Sets and queries the current year, month, and day		
Parameters	<year>	<NR1>	Year
			Range: 1998 to 2099 Resolution: 1
	<month>	<NR1>	Month
			Range: 1 to 12 Resolution: 1
	<day>	<NR1>	Day
			Range: 1 to 31 Resolution: 1
Response format	<year>,<month>,<day>		
	<year>	<NR1>	
	<month>	<NR1>	
	<day>	<NR1>	
Comments	—		

5.3.103 :SYSTem:ERRor?

Explanation	Queries the remote error		
Response format	<code>, <message>		
	<code>	<NR1>	Error number
	"<message>"	<STR>	Error message
Comments	—		

5.3.104 :SYSTem:LOCal

Explanation	Sets the local control mode
Comments	Can be used only for the RS232 and LAN interfaces

5.3.105 :SYSTem:REMote

Explanation	Sets the remote control mode
Comments	Can be used only for the RS232 and LAN interfaces

5.3.106 :SYSTem:RWLock

Explanation	Sets the LLO mode
Comments	Can be used only for the RS232 and LAN interfaces

5.3.107 :SYSTem:TIME <hour>,<minute>,<second>

:SYSTem:TIME?

Explanation	Sets and queries the current time (hour, minute, second)		
Parameters	<hour>	<NR1>	Hour Range: 0 to 23 Resolution: 1
	<minute>	<NR1>	Minute Range: 0 to 59 Resolution: 1
	<second>	<NR1>	Second Range: 0 to 59 Resolution: 1
Response format	<hour>,<minute>,<second>		
	<hour>	<NR1>	
	<minute>	<NR1>	
Comments	—		

5.3.108 :TRIGger:ABORT

Explanation	Aborts the measurement operation
Comments	—

5.3.109 :TRIGger:DELay <value>,<param>

:TRIGger:DELay? <param>

Explanation	Sets and queries the measurement delay		
Parameters	<value>	<NR1> For CYCLe	Measurement delay (cycle) Range: 0 to 9999 Resolution: 1 *RST value: 0
		<NRf> For TIMe	Measurement delay (seconds) Range: 0.000sec to 9990sec Resolution: 3 places (1 msec for <1 sec) *RST value: 0 sec
	<param>	<DISC>	Measurement delay unit CYCLe Set in units of cycles TIMe Set in units of seconds
Query parameters	<param>	<DISC>	Measurement delay query targets
			CYCLe Get the set value in cycles.
			TIMe Get the set value in seconds.
Response format	<NR1> The query parameter is CYCLe. <NR3> The query parameter is time.		
Comments	The setting range for the measurement delay values varies with the measurement delay unit that has been set.		

5.3.110 :TRIGger:DELay:TYPE?

Explanation	Queries the measurement delay type that is currently in operation
Response format	CYCL TIM
Comments	—

5.3.111 :TRIGger[:IMMediate] <param>

Explanation	Executes a trigger (starts measurement)		
Parameters	<param>	<DISC>	Sweep direction
			UP Upwards (Lower Freq ⇒ Upper Freq)
			DOWN Downwards (Upper Freq ⇒ Lower Freq)
			SPOT No sweep (Spot Freq)
Comments	—		

5.3.112 :TRIGger:SOURce <param>

:TRIGger:SOURce?

Explanation	Sets and queries the repeat status		
Parameters	<param>	<DISC>	Repeat measurement status
			INTernal Enables repeat measurement
			BUS Disables repeat measurement
Response format	INT BUS		
Comments	—		

5.3.113 :TRIGger:STTDelay <value>,<param>

:TRIGger:STTDelay? <param>

Explanation	Sets and queries the measurement start delay		
Parameters	<value>	<NR1> CYCLe	Measurement start delay value (cycles) Range: 0 to 9999 Resolution: 1 *RST value: 0
		<NRf> TIMe	Measurement start delay value (seconds) Range: 0.000sec to 9990sec Resolution: 3 places (1 msec for <1 sec) *RST value: 0 sec
	<param>	<DISC>	Measurement start delay unit
			CYCLe Set in units of cycles TIMe Set in units of seconds
Query parameters	<param>	<DISC>	Measurement start delay query targets
			CYCLe Get the setting value in cycles.
			TIMe Get the setting value in seconds.
Response format	<NR1> The query parameter is CYCLe. <NR3> The query parameter is TIMe.		
Comments	The setting range for the measurement start delay values varies with the measurement start delay unit that has been set.		

5.3.114 :TRIGger:STTDelay:TYPE?

Explanation	Queries the current measurement start delay type
Response format	CYCL TIM
Comments	—

6. Status System

6.1	Status system overview.....	6-2
6.2	Status byte	6-3
6.3	Standard event status	6-4
6.4	Operation status	6-6

6.1 Status system overview

The status system of the FRA51602 is illustrated in Figure 5-1.

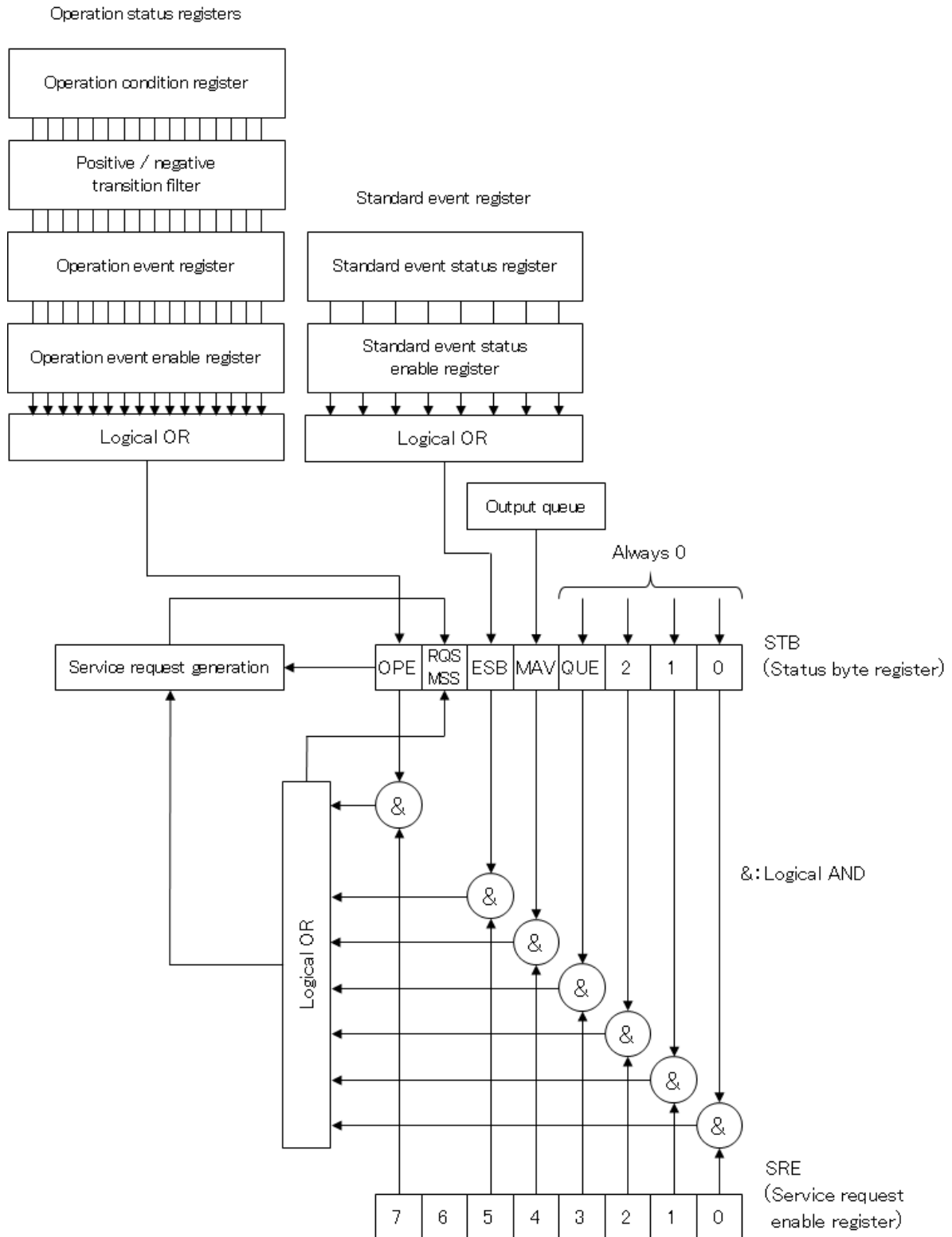

Figure 6-1 Status system

6.2 Status byte

The status byte register definitions are presented in Table 6-1. The status byte can be read by serial polling. In that case, bit 6 is RQS (Request service).

Table 6-1 Status byte register definitions

Bit		Weight	Conditions for setting to 1	Conditions for setting to 0
OPE	7	128	When any of the effective bits of the operation status event register is set to 1	<ul style="list-style-type: none"> When an device clear command is received After a status byte read command has been executed
RQS/ MSS	6	64	SRQ is sent	<ul style="list-style-type: none"> When an device clear command is received When RQS is a serial poll and the status byte has been read
ESB	5	32	When an effective bit of the standard event status register becomes 1	When all of the effective bits of the standard event status register become 0
MAV	4	16	When the response to the query has been prepared and can be output	When all of the responses have been output and there are no more responses to be output
—	3	8	—	Always 0 (not used)
—	2	4	—	Always 0 (not used)
—	1	2	—	Always 0 (not used)
—	0	1	—	Always 0 (not used)

■ Relevant commands and queries

*STB?

This queries the status byte register content.

Bit 6 is MSS (Master Summary Status).

*SRE,*SRE?

These set and query the service request enable register.

Immediately after the power is turned on, the register is cleared to zero. The status byte register bits become effective when the corresponding bits in the service request enable register are set to 1. The service request is issued when any one of the effective bits is set to one.

The message and response message parameters that are set in each register are the sums of all the weights of the bits that have the value of 1.

■ Checking status when making a query

Normally, a correct response message can be received after a query has been sent, and it is not necessary to check the MAV bit of the status byte. When the processing proceeds while the MAV bit is being checked, first check that the MAV bit of the status byte is 1 by serial polling after the query is sent and then read the response message. Then confirm that the MAV bit has changed to 0 and proceed to the next operation.

6.3 Standard event status

The structure of the standard event status is illustrated in Figure 6-2, and the details are presented in Table 6-2. If the bits of the standard event status enable register are set to 1, the corresponding bits of the standard event status register are enabled, and if any of the enabled bits take the value 1, the ESB bit of the status byte register is set to 1.

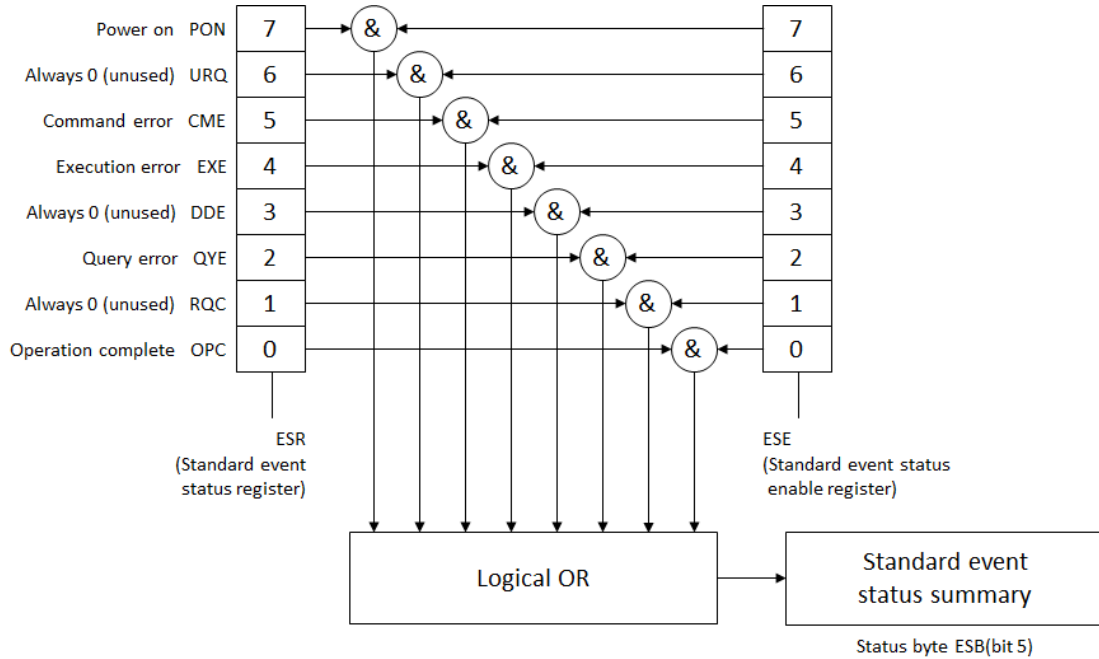

Figure 6-2 Standard event status structure

Table 6-2 Content of the standard event status register

Bit	Weight	Content
PON	7	128 Power on This bit is set to 1 when the power is turned on. It is cleared to 0 when this register is read, and the value remains 0 until the power is turned on again.
URQ	6	64 User request Always 0 (not used)
CME	5	32 Command error This bit is set to 1 when there is a syntax error and a remote command.
EXE	4	16 Execution error This bit is set to 1 when a parameter is out of range or there is a conflict in settings.
DDE	3	8 Instrument-specific error Always 0 (not used)
QYE	2	4 Query error This bit is set to 1 when a read attempt is made when there is no data in the response message output buffer or when the data in the response message output buffer has been lost.
RQC	1	2 Request control Always 0 (not used)
OPC	0	1 Operation completed This bit is set to 1 when the processing for all of the commands up to the *OPC command has been completed.

■ Relevant commands and queries

*ESR?

This command queries the standard event status register.

The query clears the register to 0. The *CLS command also clears the register.

The register is cleared to 0 immediately after the power is turned on, but the PON bit is set to 1.

*ESE, *ESE?

These commands set and query the standard event status enable register.

Set the value 0 to clear the enable register to zero.

There are no other clear commands.

The register is cleared to 0 immediately after the power is turned on.

The message and response message parameters that are set in each register are the sums of all the weights of the bits that have the value of 1.

6.4 Operation status

The operation status structure is illustrated in Figure 6-3.

The operation conditions register indicates the status of the FRA51602 as shown in Table 6-3. The transition filter detects changes in the conditions and generates events. Generating an event requires setting of the transition filter. The operation event register stores the generated events. If the operation event enable register bits are set to 1, the corresponding bits of the operation event register are enabled. If the value of any of the enabled bits is set to 1, the OPE bit of the status byte is set to 1.

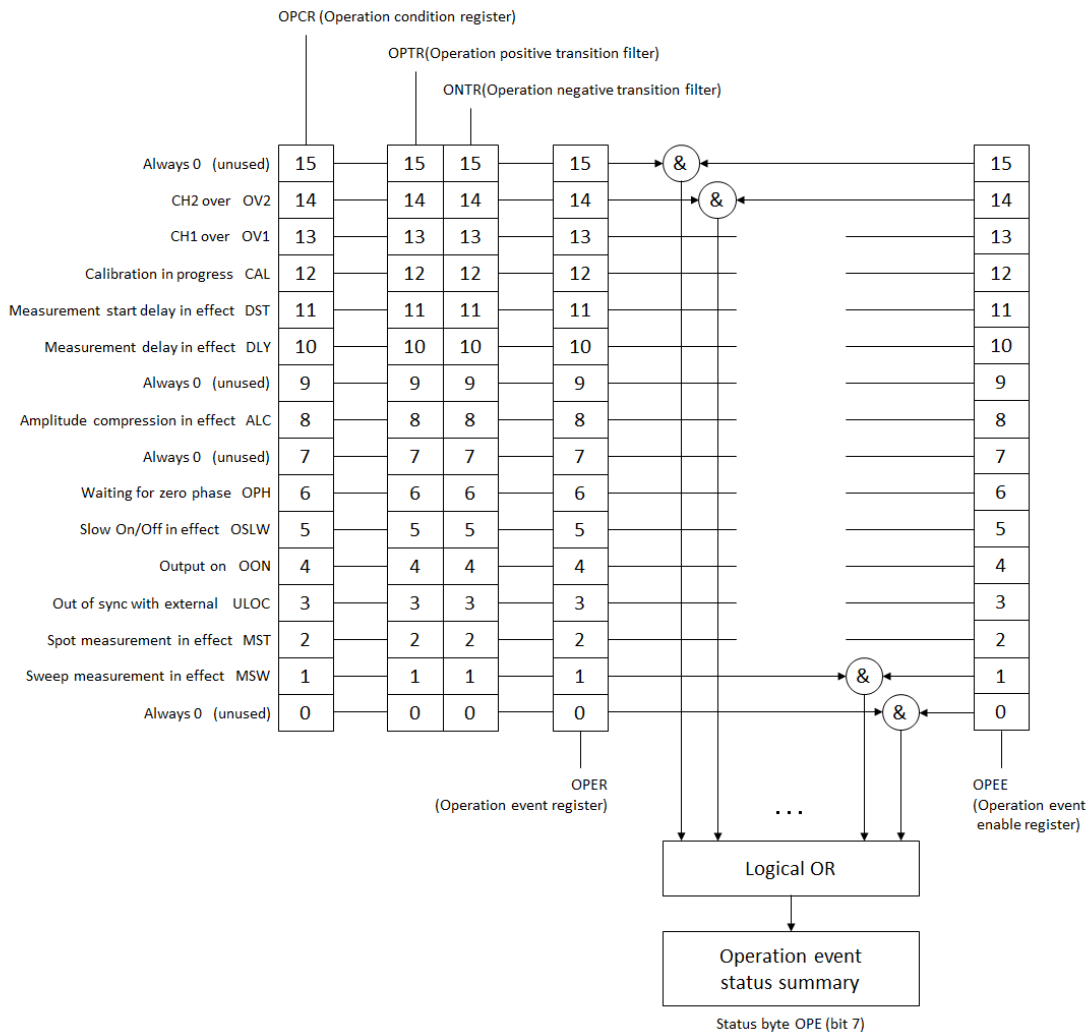

Figure 6-3 Operation status structure

Table 6-3 Contents of the operation condition register and event register

Bit		Weight	Content
—	15	32768	Always 0 (not used)
OV2	14	16384	CH2 is at over input
OV1	13	8192	CH1 is at over input
CAL	12	4096	Calibration in progress
DST	11	2048	Measurement start delay in progress
DLY	10	1024	Measurement delay in progress
—	9	512	Always 0 (not used)
ALC	8	256	Amplitude compression in progress (amplitude control in effect) (not ON/OFF setting)
—	7	128	Always 0 (not used)
OPH	6	64	0° phase stop waiting 0° phase waiting due to frequency change mode 0° phase waiting due to stop mode
OSLW	5	32	SlowON/OFF in progress
OON	4	16	Output ON in effect (also includes the following cases) During output transitioning when on/off mode is SLOW
ULOC	3	8	Out of sync with external reference signal (10 MHz) If there is a valid signal at the 10MHz Ref In terminal: 0 If there is not a valid signal at the 10MHz Ref In terminal: 1
MST	2	4	Spot measurement in progress (1 for delay, also)
MSW	1	2	Sweep measurement in progress (1 for delay, also)
—	0	1	Always 0 (not used)

■ Relevant commands and queries

:STATus:OPERation:CONDition?

This command queries the operation condition register.

Querying does not clear the register to 0.

Always indicates the status of the instrument.

:STATus:OPERation[:EVENT]?

This command queries the operation event register.

The query clears the register to 0.

The event register is also cleared by the *CLS command.

The register is cleared to 0 immediately after the power is turned on.

:STATus:OPERation:ENABLE, STATus:OPERation:ENABLE?

This command queries the operation event enable register.

To clear the enable register to 0, set the value 0.

There are no other clear commands.

The register is cleared to 0 immediately after the power is turned on.

:STATus:OPERation:NTRansition, STATus:OPERation:NTRansition?

:STATus:OPERation:PTRansition, STATus:OPERation:PTRansition?

These operations set and query the operation status transition filter.

The relationships between the transition filter settings and event register transitions are shown in Table 5-4.

Table 6-4 Operation transition filter and event register transitions

Positive transition filter bit settings	Negative transition filter bit settings	Condition register transition for changing the event register to 1
1	0	0 → 1
0	1	1 → 0
1	1	0 → 1 or 1 → 0
0	0	Event register is not changed to 1

The message and response message parameters that are set in each register are the sums of all the weights of the bits that have the value of 1.

7. Command Execution Examples

- 7.1 Spot measurement..... 7-2
- 7.2 Sweep measurement..... 7-3

7.1 Spot measurement

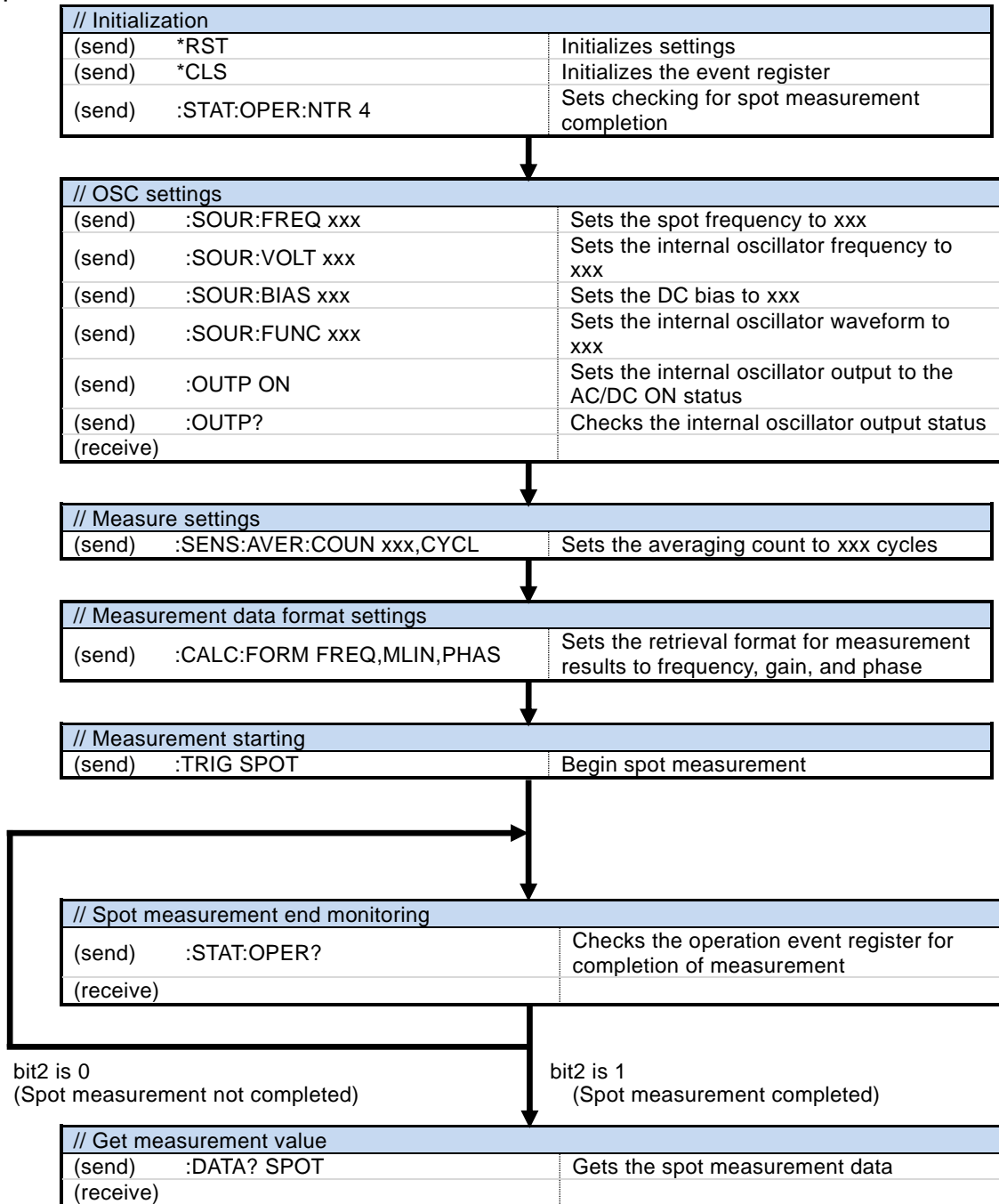

7.2 Sweep measurement

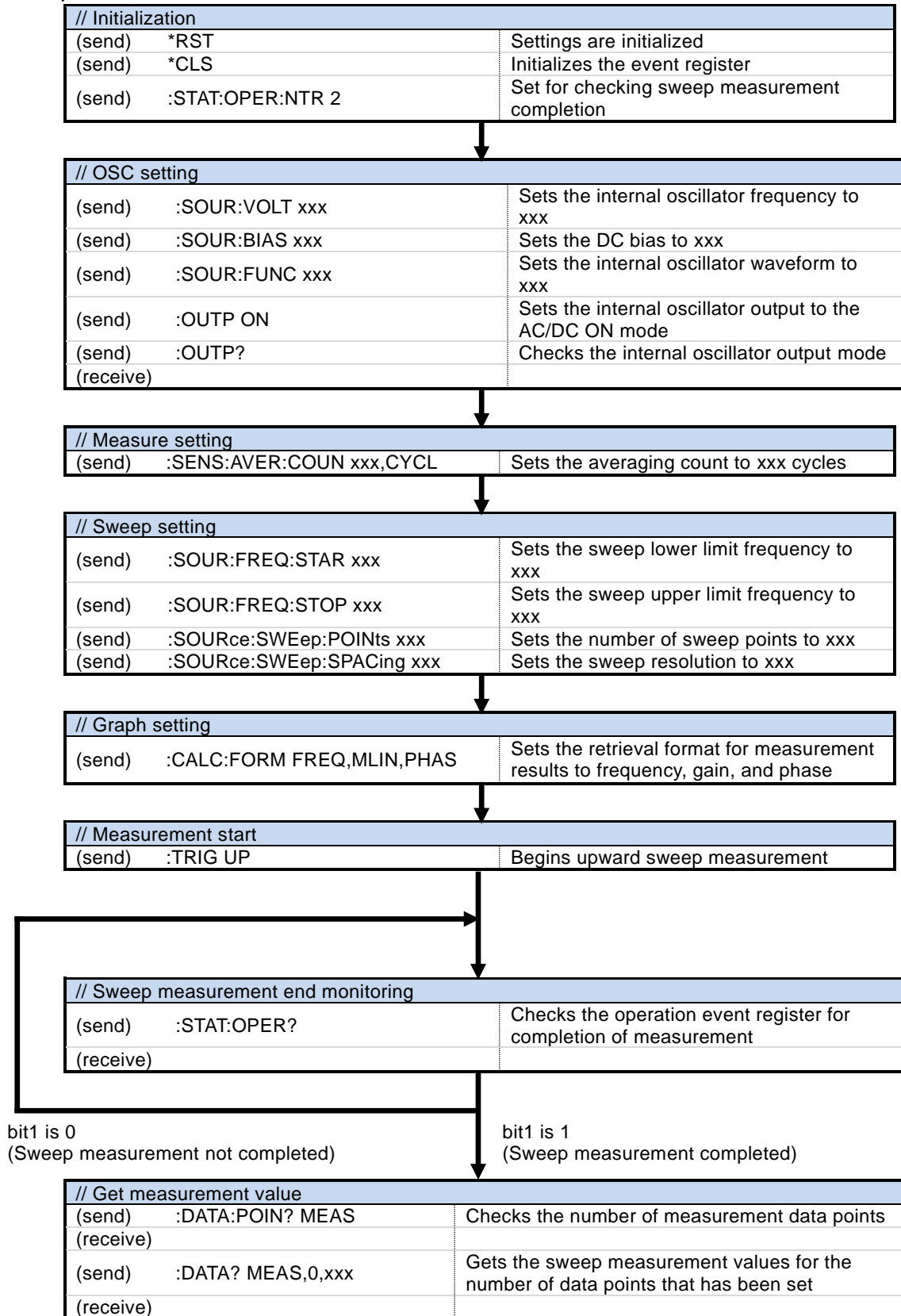

8. Error Messages

8. Error Messages

The main errors that occur in remote control are described here.

Table 8-1 Error messages 1/2

Error Number	Error Message	Description
0	No error	No abnormalities have occurred.
-101	Invalid character	There is an abnormality in text data.
-102	Syntax error	A command or data that cannot be recognized has been received.
-103	Invalid separator	There is an abnormality in a command parameter.
-104	Data type error	The parameter format is inappropriate.
-108	Parameter not allowed	There are too many parameters or there is a parameter in a place that it cannot be used.
-109	Missing parameter	There are not enough parameters.
-110	Command header error	There is an abnormality in the command header (no detailed classification).
-113	Undefined header	The command header is undefined.
-115	Unexpected number of parameters	There are too many parameters.
-120	Numeric data error	There is an abnormality in the numerical data (no detailed classification).
-123	Exponent too large	The exponent is too large (greater than 32000) (Examples) :SOURce:FREQuency:CW 1E50000
-124	Too many digits	A number has too many digits (more than 255).
-130	Suffix error	There is an abnormality in the suffix (multiplier or unit). (no detailed classification)
-134	Suffix too long	The SI prefix or unit is too long (more than 7 characters).
-140	Character data error	There is an abnormality in text data (no detailed classification).
-144	Character data too long	The text data is too long.
-200	Execution error	The command could do not be executed (no detailed classification). (Examples) • A setting operation was performed during calibration. • The calibration path check failed.
-211	Trigger ignored	A trigger was received, but execution was not possible. (Examples) • A measurement start command was executed during calibration. • A measurement start command was executed during measurement.
-221	Settings conflict	The command cannot be executed because of constraint conflicts among multiple settings. (Examples) • Amplitude and DC bias constraints • Sweep lower limit frequency and upper limit frequency constraints • Graph axis scale maximum and minimum constraints

Table 8-1 Error messages 2/2

Error Number	Error Message	Description
-222	Data out of range	The data is outside the valid range.
-224	Illegal parameter value	The parameters are incorrect (problem other than data type error). (Examples) :SOURce:FREQuency:CW %1
-310	System error	An instrument-specific internal error has occurred (memory content lost, etc.).
-350	Queue overflow	The error queue has overflowed and can accommodate no new errors. (The error queue has more than 16 items.)
-410	Query INTERRUPTED	The next command was received before all of the requested responses were sent. The response was interrupted and the output buffer was cleared. (Does not occur with LAN or RS232 interfaces.)
-420	Query UNTERMINATED	The received query was incomplete, so the requested response could not be sent. The output buffer was cleared. (Does not occur with LAN or RS232 interfaces.)
-440	Query UNTERMINATED after indefinite response	There was a query following “*IDN?” within a text string. (“*IDN?” must be the last query in a received text string.)

Remote control errors are placed in the error queue and can be read one at a time in order of oldest first with the query “:SYSTem:ERRor?”. If a read operation is executed after all of the errors have been read, 0, “No error” is returned. The error queue can be cleared with the *CLS command.

If a problem occurs that results in data remaining in the input buffer or output buffer, the buffers can be cleared with a device clear interface message (DCL,SDC).

Errors other than those described above may occur in some situations. In such cases, check the error message for a summary.

For operations that can also be performed from the panel, the displayed error messages are the same as those that result from panel operation. Refer to the explanation for the panel operations that are relevant to each command and query. Errors that occur during normal measurement are also displayed in the same way under remote control operation.

WABUN: (DA00062764-003)

Notes

- Reproduction of the contents of this manual in part or in whole is forbidden by applicable laws.
- The contents of this manual may be revised without notice.
- Information provided in this manual is intended to be accurate and reliable. However, the NF Corporation assumes no responsibility for any damage or other effects related to the contents of this manual. Regarding any inaccuracies, omissions or other problems with the content of this manual, please contact the NF Corporation or its distributor.

FRA51602 INSTRUCTION MANUAL (REMOTE CONTROL)

NF Corporation

3-20 Tsunashima Higashi 6-chome, Kohoku-ku. Yokohama-shi 223-8508, Japan

Phone +81-45-545-8128

Fax +81-45-545-8187

<http://www.nfcorp.co.jp/>

© Copyright 2017-2020, **NF Corporation**

