



PROGRAMMABLE CURRENT AMPLIFIER

CA5350

Instruction Manual

DA00043807-003

PROGRAMMABLE CURRENT AMPLIFIER

CA5350
Instruction Manual

Preface

Thank you very much for purchasing our “**CA5350 PROGRAMMABLE CURRENT AMPLIFIER**”.

To ensure safe and proper use of this electrical equipment, please read first “**Safety Precautions**” on the following pages.

● Caution Symbols Used in This Manual

The following caution symbols are used in this manual. Be sure to observe these caution symbols and their contents to ensure the safety of the user and avoid damage to the equipment.

WARNING

Equipment handling could result in death or serious injury. This symbol contains information to avoid such risk.

CAUTION

Equipment handling could result in minor or moderate injury or property damage. This symbol contains information to avoid such risk.

● The scope of this Manual

This manual describes the **CA5350** that conform to requirements of CE Marking. Products without CE Marking affixed, may not meet directives for CE Marking (EMC and others). Please confirm the CE Marking is affixed on the rear panel.

If using this equipment for the first time, start from “**1. OUTLINE**”.

1. **OUTLINE**

This chapter describes the overview, features, applications, functions and simple operation principle of this product.

2. **PREPARATIONS BEFORE USE**

This chapter describes important preparation before installation and operation.

3. **PANEL FEATURES AND BASIC OPERATIONS**

This chapter describes the functions and simple operations available for each part in the panel. Read while operating the equipment.

4. **ADVANCED OPERATIONS**

This chapter describes advanced operations.

5. **REMOTE CONTROL**

This chapter describes remote control through GPIB or USB.

6. **TROUBLESHOOTING**

This chapter describes how to deal with error messages and troubles.

7. **MAINTENANCE**

This chapter describes storage, repacking transportation as well as performance testing.

8. **SPECIFICATIONS**

This chapter describes the product’s specifications (functions and performance).

———— Safety Precautions ————

To ensure safe use, be sure to observe the following warnings and cautions.

NF Corporation shall not be held liable for damages that arise from a failure to observe these warnings and cautions.

This product is a Class I product (with protective conductor terminal) that conforms to the JIS and IEC insulation standards.

- **Be sure to observe the contents of instruction manual.**

This instruction manual contains information for the safe operation and use of this product.

Be sure to read this information first before using this product.

All the warnings in the instruction manual must be heeded to prevent hazards that may cause major accidents.

- **Be sure to ground the product.**

To prevent electric shock, be sure to safely implement grounding such that ground resistance is 100Ω or lower.

This product is automatically grounded when its three-pin power supply plug is connected to the power outlet with a protective-ground contact.

When using a three-pin to two-pin conversion adapter, be sure to connect the grounding wire of the adapter to the grounding terminal next to the outlet.

- **Check the power supply voltage**

This product operates under the power supply voltage indicated in “Grounding and Power Supply Connection” in this instruction manual.

Before connecting the power supply, check that the voltage of the power supply matches the rated power supply of this product.

- **Observe the fuse rating**

Using an unspecified fuse could cause a fire. Use the rated fuse specified in “Grounding and Power Supply Connection” of the instruction manual.

Also, when replacing the fuse, the power cord must be disconnected from the power outlet.

- **In case of suspected anomaly**

If this product emits smoke, an abnormal smell, or abnormal noise, immediately power it off and stop using it.

If such an abnormal occurs, prevent anyone from using this product until it has been repaired, and immediately report the problem to NF Corporation or one of our representatives.

- **Do not use this product when there is gas around.**

An explosion or other such hazard may occur.

● **Do not remove the cover.**

This product contains high-voltage parts. Absolutely never remove its cover. Even when the inside of this product needs to be inspected, do not touch the inside. All such inspections should be performed by service technicians designated by NF Corporation.

● **Do not modify this product.**

Absolutely never modify this product, as this may cause new hazards and may disqualify this product from repair in case of failure.

● **Ensure that water does not get into this product or it does not get wet.**

Using the product in wet condition may cause electric shock and fire. When water etc. get into the product, immediately pull out the power supply cord, and contact NF Corporation or one of our representatives from where you bought the product.

● **In the event of thunderstorm in the nearby area, turn off the power supply switch, and pull out the power supply cord.**

Thunderstorm may cause electric shock, fire, and breakdown.

● **Safety-related symbols**

The general definitions of the safety-related symbols used on this product and in the instruction manual are provided below.



Instruction Manual Reference Symbol

This symbol is displayed to alert the user to potential danger and refer him/her to the instruction manual.



Electric Shock Danger Symbol

This symbol indicates locations that present a risk of electric shock under specific conditions.



Warning Symbol

This symbol indicates information for the avoidance of a hazard such as electric shock that may endanger human life or cause serious injury during handling of the equipment.



Caution Symbol

This symbol indicates information for minor or moderate injury, or property damage to the equipment during handling.

● **Other Symbols**



This symbol indicates the “on” position of the power switch.



This symbol indicates the “off” position of the power switch.



This symbol indicates that external conductor of the connector is connected to the case.



This symbol indicates that the external conductor of connector is connected to the signal ground.

—— Electromagnetic Compatibility ——

This product may cause interference if used in residential areas. Such use must be avoided unless the user takes special measures to reduce electromagnetic emissions to prevent interference to the reception of radio and television broadcasts.

—— Note on Waste Processing ——

To protect the environment, ensure that this device is disposed of by an appropriate industrial waste processor. This product does not use batteries or a backlight that contains mercury.

Contents

	Page
1. OUTLINE	1-1
1.1 Features	1-2
1.2 Applications	1-2
1.3 List of Functions	1-3
1.4 Principle of Operation	1-4
2. PREPARATIONS BEFORE USE	2-1
2.1 Checking Before Use	2-2
2.2 Installation	2-3
2.2.1 General Precautions for Installation	2-3
2.2.2 Installation Conditions	2-3
2.2.3 Rack Mounting	2-4
2.3 Grounding and Power Supply Connection	2-13
2.4 Simplified Operation Check	2-15
2.4.1 Checking operation and display at power on	2-15
2.4.2 Checking key operation and response	2-15
2.5 Calibration	2-16
3. PANEL FEATURES AND BASIC OPERATIONS	3-1
3.1 Panel Component Names and Functions	3-2
3.1.1 Front panel	3-2
3.1.2 Rear panel	3-3
3.2 Display at Power "ON" and Initial Setting	3-4
3.2.1 Displays and Indications at Power "ON"	3-4
3.2.2 Initialization	3-5
3.3 I/O Terminals	3-6
3.4 I/O Connection	3-9
3.4.1 Connection of optical sensor (photodiode)	3-10
3.4.2 Connection with lock-in amplifier, etc	3-12
3.5 Operation Tree	3-13
3.6 Basic Operation Examples	3-15
3.6.1 Basic Key Operations	3-15
3.6.2 Simplified Operating Method When You Use Device for the First Time	3-17
3.6.3 Initialization	3-18
3.6.4 Basic Settings	3-19
3.6.4.1 Input switching	3-19
3.6.4.2 Zero Check	3-19

3.6.4.3	Gain Setting	3-19
3.6.4.4	Filter Setting.....	3-20
4.	ADVANCED OPERATIONS	4-1
4.1	Zero Check	4-2
4.2	Cancelling the dark current of sensor	4-3
4.2.1	Manually setting the current value to be cancelled	4-4
4.2.2	Automatically deciding the current value to be cancelled	4-4
4.3	Setting DC Bias Voltage	4-6
4.4	Saving/Recalling the Settings	4-7
4.5	Self-diagnosis	4-8
4.6	Adjusting the LCD backlight brightness	4-9
4.7	Checking Various Information	4-10
4.7.1	Checking the Version.....	4-10
4.7.2	Checking the Production Number	4-10
4.7.3	Checking USB related ID	4-10
5.	REMOTE CONTROL	5-1
5.1	Preparations Before Use	5-2
5.1.1	Remote Control Interface Selection	5-2
5.1.2	Outline of USB.....	5-3
5.1.2.1	Preparation of Controller	5-3
5.1.2.2	Preparation of CA5350.....	5-3
5.1.2.3	USB Device Identification.....	5-3
5.1.3	Outline of GPIB.....	5-4
5.1.3.1	Preparation of Controller	5-4
5.1.3.2	Preparation of CA5350.....	5-4
5.1.3.3	Precautions on Use of GPIB	5-4
5.1.3.4	Basic Specifications of GPIB	5-5
5.1.4	Precautions on Communication	5-5
5.2	Switching between Remote State and Local State	5-6
5.3	Response to Interface Message	5-7
5.4	Service Request and Status Byte	5-8
5.4.1	Service Request	5-8
5.4.2	Status Byte	5-8
5.5	Commands Explanation.....	5-9
5.6	Description of Individual Command	5-11
5.7	Multiline Interface Messages	5-22
6.	TROUBLESHOOTING	6-1
6.1	Error Messages	6-2
6.1.1	Errors at Power "ON"	6-2

6.1.2	Errors at Panel Operation	6-3
6.1.3	Error during Operation	6-3
6.1.4	Errors in Remote Control	6-3
6.2	When the Device Appears to be a Problem	6-4
7.	MAINTENANCE	7-1
7.1	Introduction.....	7-2
7.2	Daily Maintenance	7-2
7.3	Storage, Repackaging, and Transport.....	7-3
7.4	Checking the Version Number	7-3
7.5	Performance Testing	7-4
7.5.1	Current suppression setting accuracy, gain accuracy	7-5
7.5.2	Output offset voltage.....	7-6
7.5.3	DC bias voltage setting accuracy.....	7-6
7.6	Calibration	7-7
8.	SPECIFICATIONS	8-1
8.1	Specifications	8-2
8.1.1	Input section	8-2
8.1.2	Current suppression section	8-3
8.1.3	Amplifier section	8-3
8.1.4	Output section	8-4
8.1.5	DC bias voltage output section	8-4
8.1.6	General information	8-5
8.2	External Dimensions.....	8-7

Figures

	Page
Figure 1-1 Block Diagram	1-4
Figure 2-1 Dimensional drawing of rack-mount (EIA, for 1 unit)	2-5
Figure 2-2 Dimensional drawing of rack-mount (EIA, for 2 units)	2-6
Figure 2-3 Dimensional drawing of rack-mount (JIS, for 1 unit)	2-7
Figure 2-4 Dimensional drawing of rack-mount (JIS, for 2 units)	2-8
Figure 2-5 Assembly drawing of rack-mount kit (EIA, for 1 unit)	2-9
Figure 2-6 Assembly drawing of rack-mount kit (EIA, for 2 units)	2-10
Figure 2-7 Assembly drawing of rack-mount kit (JIS, for 1 unit)	2-11
Figure 2-8 Assembly drawing of rack-mount kit (JIS, for 2 units)	2-12
Figure 3-1 Front panel	3-2
Figure 3-2 Rear panel	3-3
Figure 3-3 I/O Terminals	3-6
Figure 3-4 Input terminal	3-7
Figure 3-5 Output terminal	3-7
Figure 3-6 Output polarity	3-7
Figure 3-7 DC bias voltage output terminal	3-8
Figure 3-8 Connection of sensor without bias	3-10
Figure 3-9 Connection of reverse bias sensor	3-10
Figure 3-10 Example of connection with photomultiplier	3-11
Figure 3-11 When the signal source is grounded	3-12
Figure 3-12 When the signal source cannot be grounded	3-12
Figure 3-13 CA5350 outline block diagram	3-20
Figure 3-14 Definition of the startup time	3-22
Figure 4-1 Input circuit	4-2
Figure 4-2 Block diagram of current suppression	4-3
Figure 4-3 Connecting to DC bias voltage	4-6
Figure 8-1 CA5350 External Dimensions	8-7

Tables

	Page
Table 2-1 Package contents.....	2-2
Table 3-1 Setting items and initial values list.....	3-5
Table 3-2 I/V Gain Settings and Auto-Filter Settings	3-21
Table 3-3 Filter setting and settling time.....	3-23
Table 3-4 Filter setting and bandwidth	3-23
Table 4-1 Current suppression setting range and resolution	4-3
Table 5-1 Responses to interface messages	5-7
Table 5-2 Status Byte	5-8
Table 5-3 Priority of Execution of Commands	5-9
Table 5-4 Header List.....	5-11
Table 6-1 Error message list at Power "ON"	6-2
Table 6-2 List of error messages when operating the panel	6-3
Table 6-3 List of error messages during operation	6-3
Table 6-4 List of error messages during remote control	6-3
Table 6-5 When the device appears to be a problem	6-4

1. OUTLINE

1.1	Features.....	1-2
1.2	Applications.....	1-2
1.3	List of Functions.....	1-3
1.4	Principle of Operation.....	1-4

1.1 Features

“**CA5350 PROGRAMMABLE CURRENT AMPLIFIER**” is the current input type preamplifier that converts the input current signal from photo multiplier or photo diode into voltage signal. It has both high gain and wide frequency band, and can be varied over a wide range from 10k (V/A) to 10G(V/A). Besides, it is equipped with filters with rise time from 1 μ s to 300ms, which allows removing unnecessary noise components and improve SNR (signal noise ratio) of the signal. Furthermore, it is also equipped with a current suppression unit(± 8 nA \sim ± 800 μ A full scale) for cancelling dark current of the sensor.

This product also has GPIB and USB interface, by which gain and various other settings can be changed from the external controllers such as a personal computer. Automatic measurement system can also be easily built.

■ High sensitivity, wide band

DC \sim 14kHz (response speed 25 μ s) when 10G(V/A) and DC \sim 500kHz (response speed 0.7 μ s) when 1M(V/A).

■ Stable with respect to the source capacitance

Even when the source capacitance of 1000pF is added, it operates stably without any concerns of oscillations. Besides, overshoot and ringing will not occur in the pulse response.

■ Variable Gain

Gain can be set in the range of 10k(V/A) \sim 10G(V/A) with a step by 10 times (7 range). Moreover, by setting the output amplifier to $\times 10$ times, maximum 100G(V/A) of gain setting is possible.

■ Variable Filters

It is equipped with filters (low pass filter) with the rise time in the range of 1 μ s \sim 300ms by 1-3 sequence in 12 ways. They can remove the noise components and improve the SNR.

■ Current suppression

It is equipped with current suppression for cancelling the dark current of sensor. It covers the full scale ± 8 nA \sim ± 800 μ A in 6 range.

■ Remote control

Because USB and GPIB interfaces are equipped as standard features, you can build an automatic measurement system.

1.2 Applications

- High sensitivity detection of output current signal from photomultiplier or photo diode.
- Measuring weak electrical current signal from electrochemical cells
- Material research of dielectric substances, etc.

1.3 List of Functions

The following shows the outline of functional tree of **CA5350**.

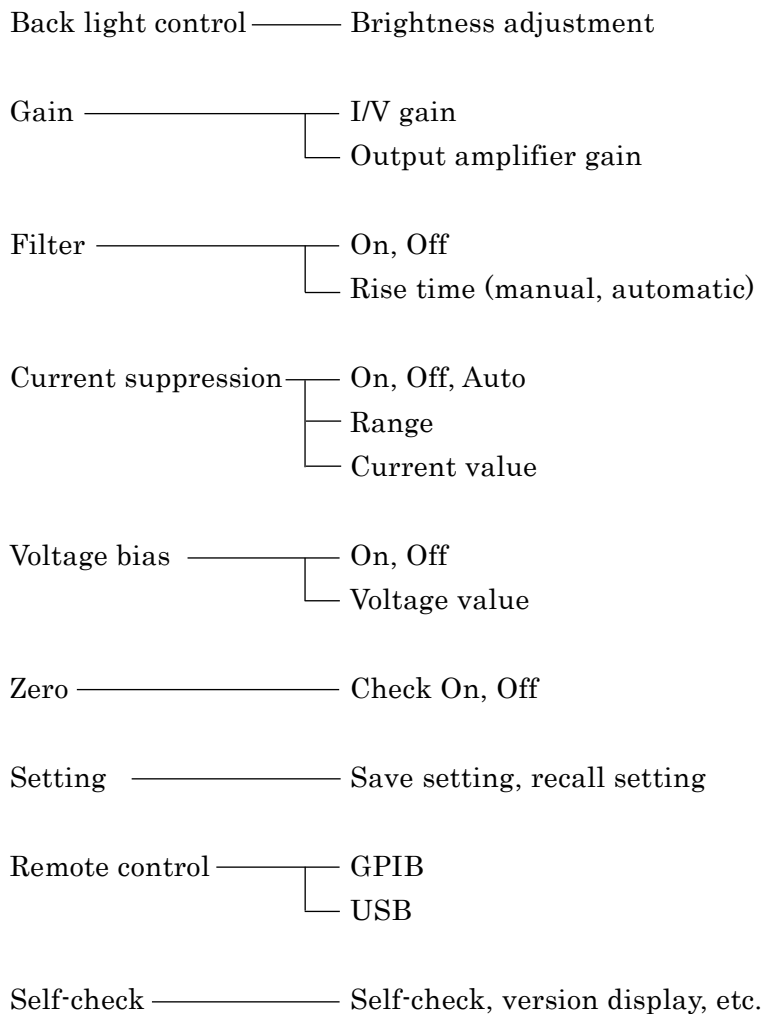

1.4 Principle of Operation

The current signal input to CURRENT INPUT is amplified to a voltage signal by I/V Amp, and output by an output amplifier after a low pass filter.

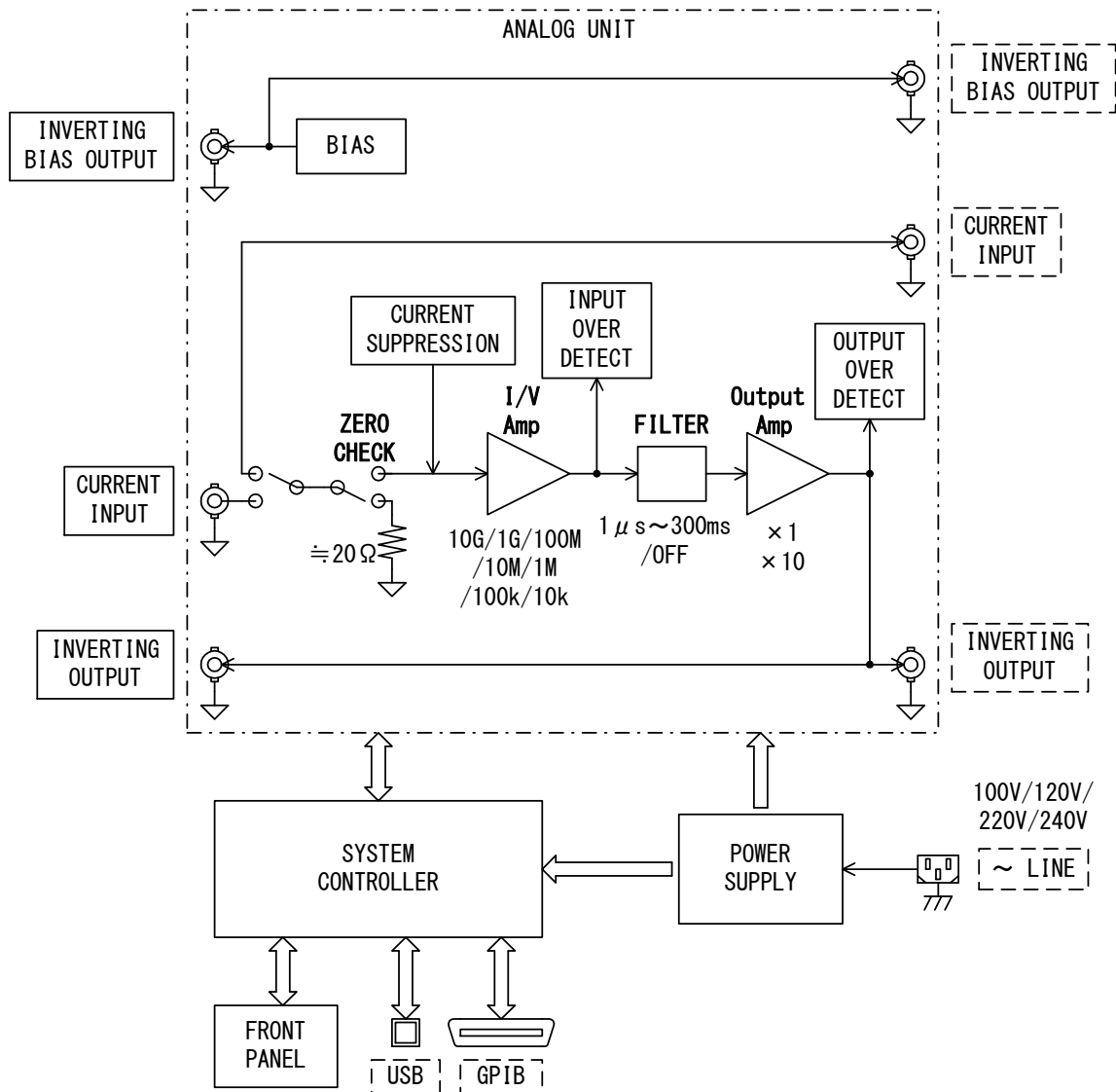

Figure 1-1 Block Diagram

- ZERO CHECK

It disconnects the input connection and cut off the input current. It is used to check whether there is current output from the sensor, or output offset from CA5350 itself.

- CURRENT SUPPRESSION

It is equipped with CURERNT SUPPRESSION for canceling the offset current of the sensor. Since the canceling offset current can be set up to $\pm 0.8mA$, and it is possible to set a huge gain of I/V Amp, it can be well detected in high sensitivity even a weak change in the current.

- **FILTER**

It is equipped with filter that allows setting the rise time in the range of $1\mu\text{s} \sim 300\text{ms}$ in by 1-3 sequence. You can remove unnecessary noise components and extract the required signal component.

- **BIAS**

For sensors those require DC bias, voltage bias source equipped that allows to output any DC voltage in the range of -8V to $+8\text{V}$ (resolution 0.001V) will be useful.

- **SYSTEM CONTROLLER**

System controller sets and controls the analog parts according to user operations, and it displays various information on the front panel LCD. Besides, it can also communicate (remote I/F control) with the host controller.

2. PREPARATIONS BEFORE USE

2.1	Checking Before Use	2-2
2.2	Installation.....	2-3
2.2.1	General Precautions for Installation.....	2-3
2.2.2	Installation Conditions	2-3
2.2.3	Rack Mounting	2-4
2.3	Grounding and Power Supply Connection.....	2-13
2.4	Simplified Operation Check.....	2-15
2.4.1	Checking operation and display at power on	2-15
2.4.2	Checking key operation and response.....	2-15
2.5	Calibration.....	2-16

2.1 Checking Before Use

■ Safety check

Before using **CA5350**, make sure you have read “**Safety Precautions**”, Located at the beginning of this instruction manual and observe the required cautions.

Before turning the power on, read “**2.3 Grounding and Power Supply Connection**” and observe the necessary cautions.

■ Unpacking

Initially, check that the device has not been damaged during transit.

After unpacking, make sure that the contents listed in “**Table 2-1 Package Contents**” are supplied.

Table 2-1 Package contents

CA5350 Main unit	1
Accessories	
Instruction Manual	1
Power Cord Set (3 Pole, 2m)	1
Fuse [Note1] (100V/120V: 1A or 220V/240V: 0.5A)	1
(Time lag, $\phi 5.2 \times 20\text{mm}$)	

[Note1] Fuse is built in the fuse holder.

WARNING

This device contains high-voltage parts. Never remove the cover.
The internal parts of this device must only be serviced by an engineer who has a thorough understanding of risk prevention.

2.2 Installation

2.2.1 General Precautions for Installation

⚠ CAUTION Take the following precautions to prevent damage to CA5350.

- **CA5350** is cooled by forced air-cooling. When you find that the fan has stopped, turn off the power switch immediately and please contact NF Corporation or one of our representatives. Using the product with the fan stopped may increase the damage, thus makes the repair impossible.
- The **CA5350** must be installed horizontally (with the bottom panel facing the floor). Using the device with the rear panel or side panel facing downward (in the upright position) causes the device to be toppled down easily, which leads to a danger.

■ Handling of the panel and case

When the case/panel surface needs to be cleaned, wipe it with a soft cloth. To remove persistent stains, wipe with a soft cloth soaked with neutral detergent and wrung out. Do not use any organic solvents like thinner or benzene, or any chemical cleaning cloth, as they may cause the surface coating to deteriorate, tarnish, or peel off.

2.2.2 Installation Conditions

Install **CA5350** in a location that fills the following temperature and humidity requirements.

Operating:	0 to +40°C, 5 to 85% RH (where absolute humidity is 1 to 25g/m ³ , non-condensing) Altitude: 2000m or less
Performance guarantee:	23±5°C, 5 to 85% RH (where absolute humidity is 1 to 25g/m ³ , non-condensing) Altitude: 2000m or less
Storage:	-10 to +50°C, 5 to 95% RH (where absolute humidity is 1 to 29g/m ³ , non-condensing)

Do not install at the following places

- Places with inflammable gases
Danger of explosion. Never install or use at such place.
- Outdoors or place with direct exposure to sunlight or place near fire or heat source
Performance may decline and product may trouble.
- Places with corrosive gases, moisture and dust, highly humid places
May result in corrosion, trouble and performance deterioration.
- Near electromagnetic source or high voltage device or power lines
May result in malfunction of the product.
- Places with lot of vibration
Noise increases, which may result in measurement error or malfunction.

2.2.3 Rack Mounting

CA5350 can be mounted on a 19-inch IEC rack, an EIA specification rack or a JIS standard rack by the use of a rack-mount kit (optional). The rack-mount kit is available with metric (JIS) type and inch (EIA) type.

First, mount the rack-mount adapter on the device as shown in “**Fig. 2-5 Assembly drawing of rack-mount (EIA, for 1 unit)**” to “**Fig. 2-8 Assembly drawing of rack -mount (JIS, for 2 units)**”, and then, mount the device in the rack.

Take the following precautions when you mount the device on the rack:

- **Be sure to install rack rails to support the CA5350.**
- **Mounting CA5350 in a closely sealed rack may cause the temperature increased, results in malfunction.**
Provide proper air vents in the rack, or install fans for forced convection inside the rack.
Besides, when mounting other equipments above or below the product, leave open space for 40 mm or more below **CA5350** for heat dissipation.
- **Ensure that CA5350 does not vibrate and it is not directly exposed to wind.**
CA5350 is highly sensitive amplifier. Vibration may easily overlap noise in the output signal. Because wind may also become a source of noise, ensure that **CA5350** is not directly blew by a strong wind.
- **Ensure that the input cable is not subject to vibration.**
Vibration will cause microphonic noise in the cable, increasing the output noise in **CA5350**. If required, fix the cable with shock-absorption material before using.
- **Avoid places with a lot of dust, or places with high humidity.**
Insulation resistance will decline and leaked current will increase, which would result in the decline of performance.

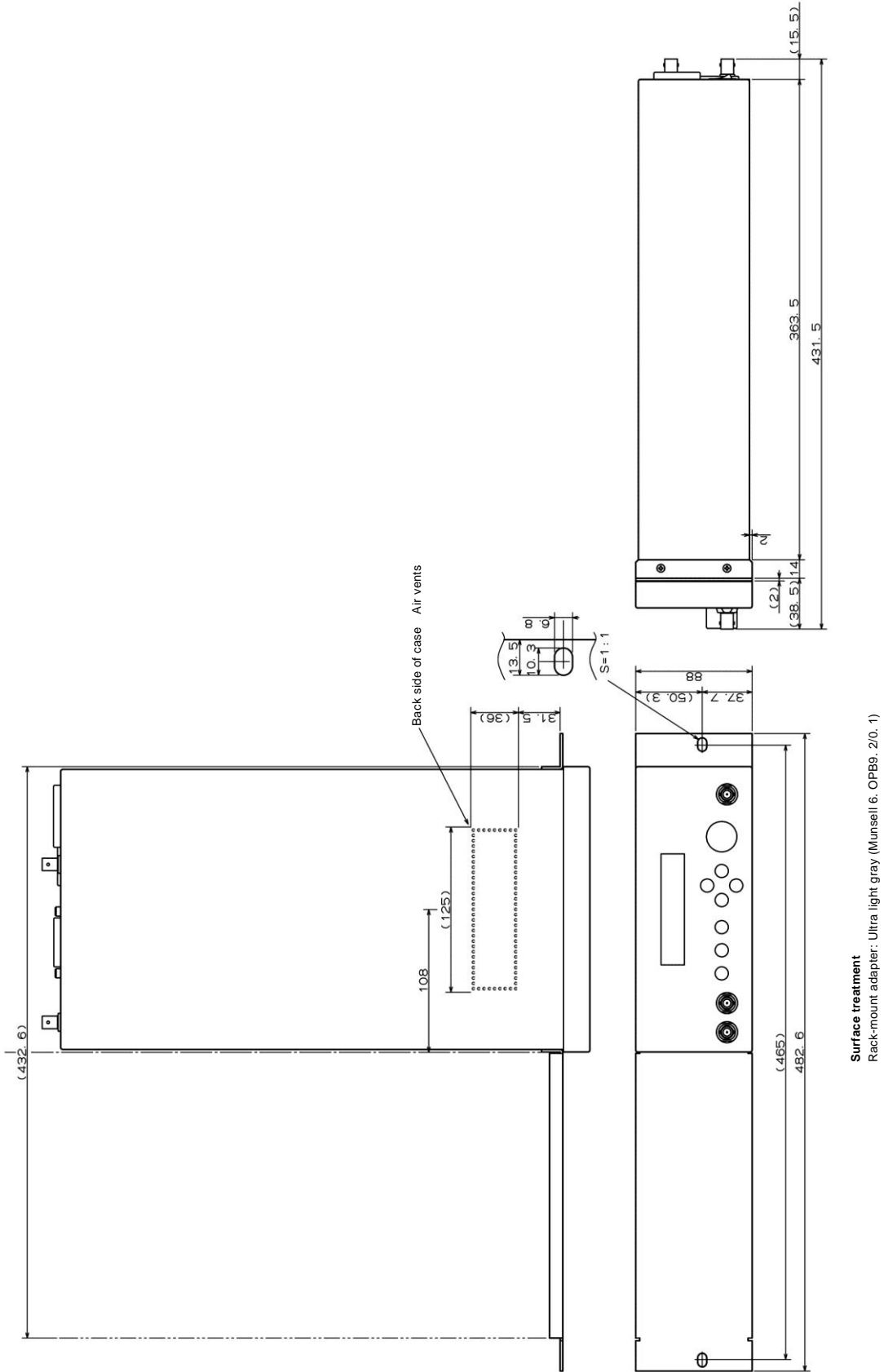

Figure 2-1 Dimensional drawing of rack-mount (EIA, for 1 unit)

Surface treatment
 Rack-mount adapter: Ultra light gray (Munsell 6. OPB9. 2/0. 1)

CAUTION
 When mounting in the rack, install angle bars or shelf in the rack to support the body.
 Do not hold the device by the accessory rack-mount adapter only.
 Do not block air vents in the bottom of case.

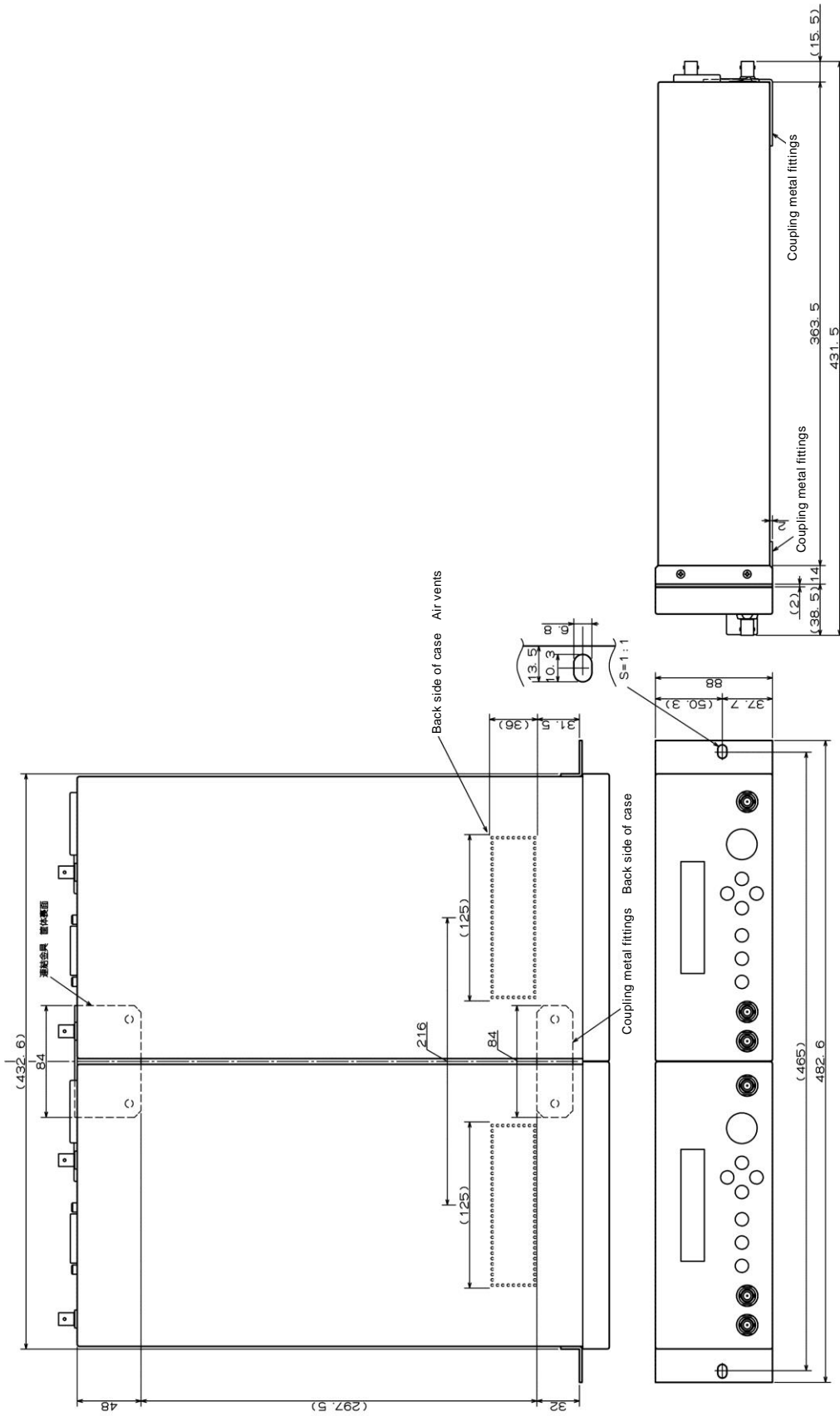
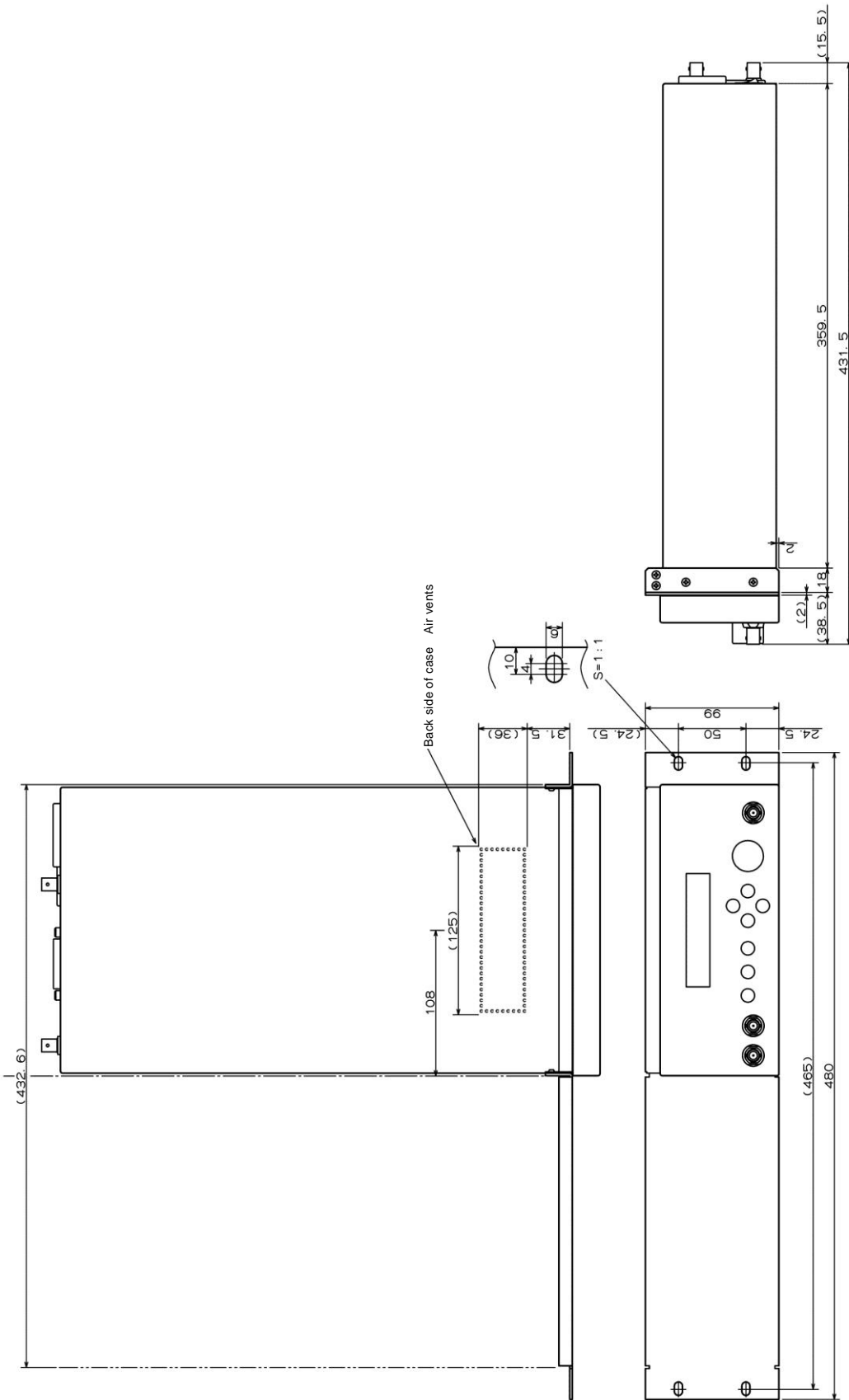

Figure 2-2 Dimensional drawing of rack-mount (EIA, for 2 units)

Surface treatment
 Rack-mount adapter: Ultra light gray (Munsell 6, OPB9, 2/0. 1)

CAUTION
 When mounting in the rack, install angle bars or shelf in the rack to support the body.
 Do not hold the device by the accessory rack-mount adapter only.
 When hold with shelf, be careful about plate thickness of the coupling metal fitting.
 Do not block air vents in the bottom of case.



Surface treatment
 Rack-mount adapter: Ultra light gray (Munsell 6. OPB9. 2/0. 1)

CAUTION
 When mounting in the rack, install angle bars or shelf in the rack to support the body.
 Do not hold the device by the accessory rack-mount adapter only.
 Do not block air vents in the bottom of case.

Figure 2-3 Dimensional drawing of rack-mount (JIS, for 1 unit)

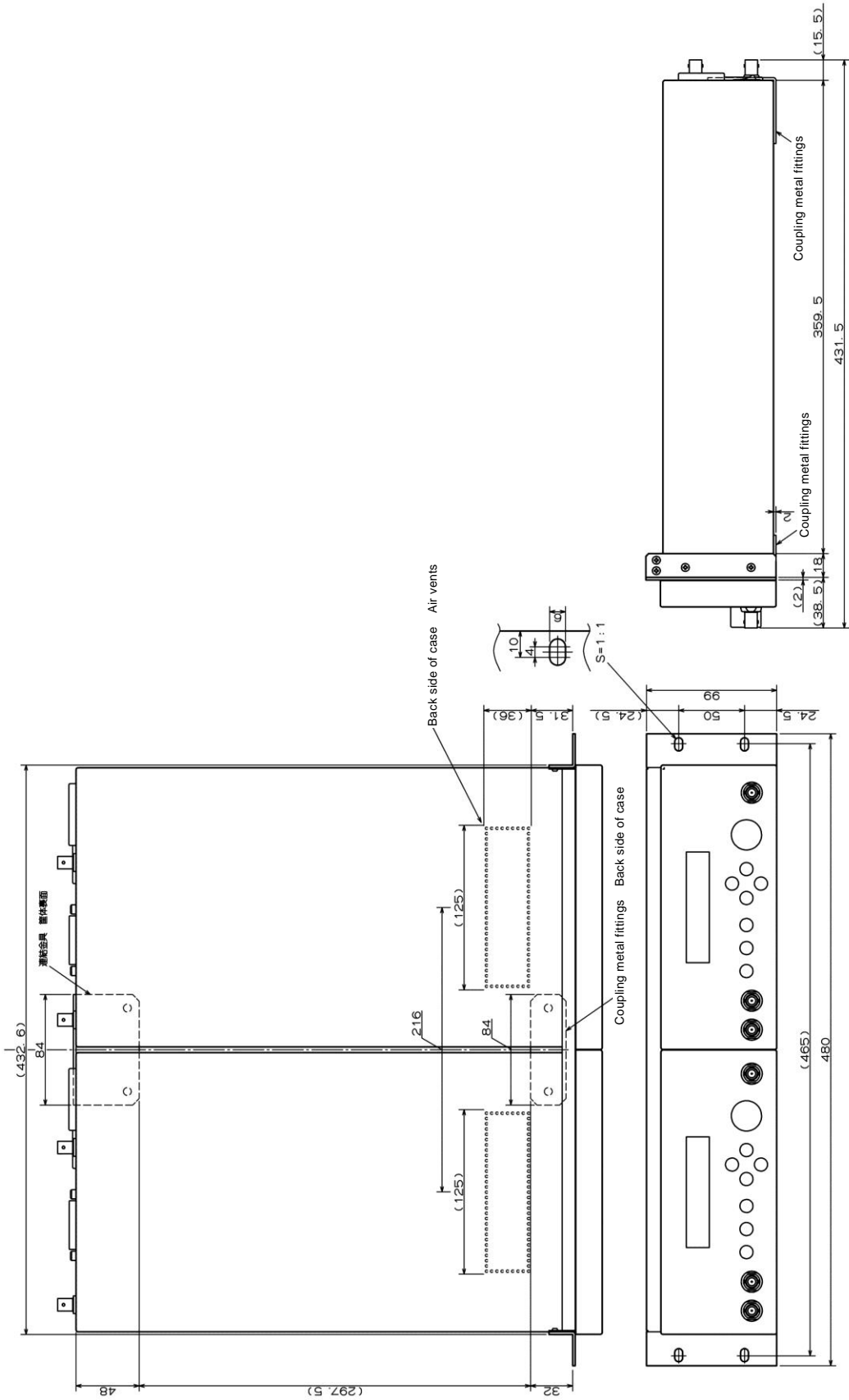

Figure 2-4 Dimensional drawing of rack-mount (JIS, for 2 units)

Surface treatment
 Rack-mount adapter: Ultra light gray (Munsel 6. OPB9. 2/0. 1)

CAUTION

When mounting in the rack, install angle bars or shelf in the rack to support the body.
 Do not hold the device by the accessory rack-mount adapter only.
 When hold with shelf, be careful about plate thickness of the coupling metal fitting.
 Do not block air vents in the bottom of case.

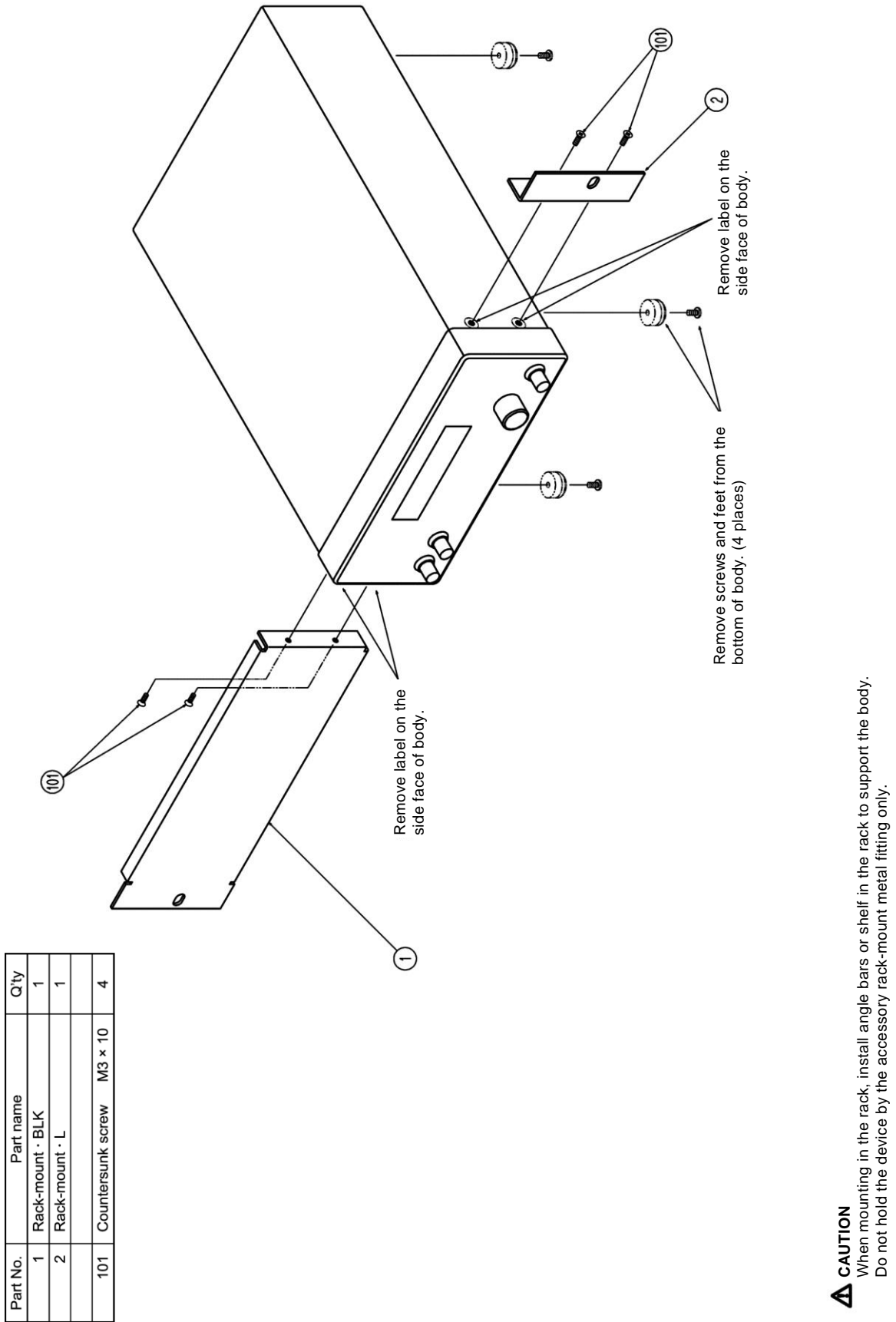

Figure 2-5 Assembly drawing of rack-mount kit (EIA, for 1 unit)

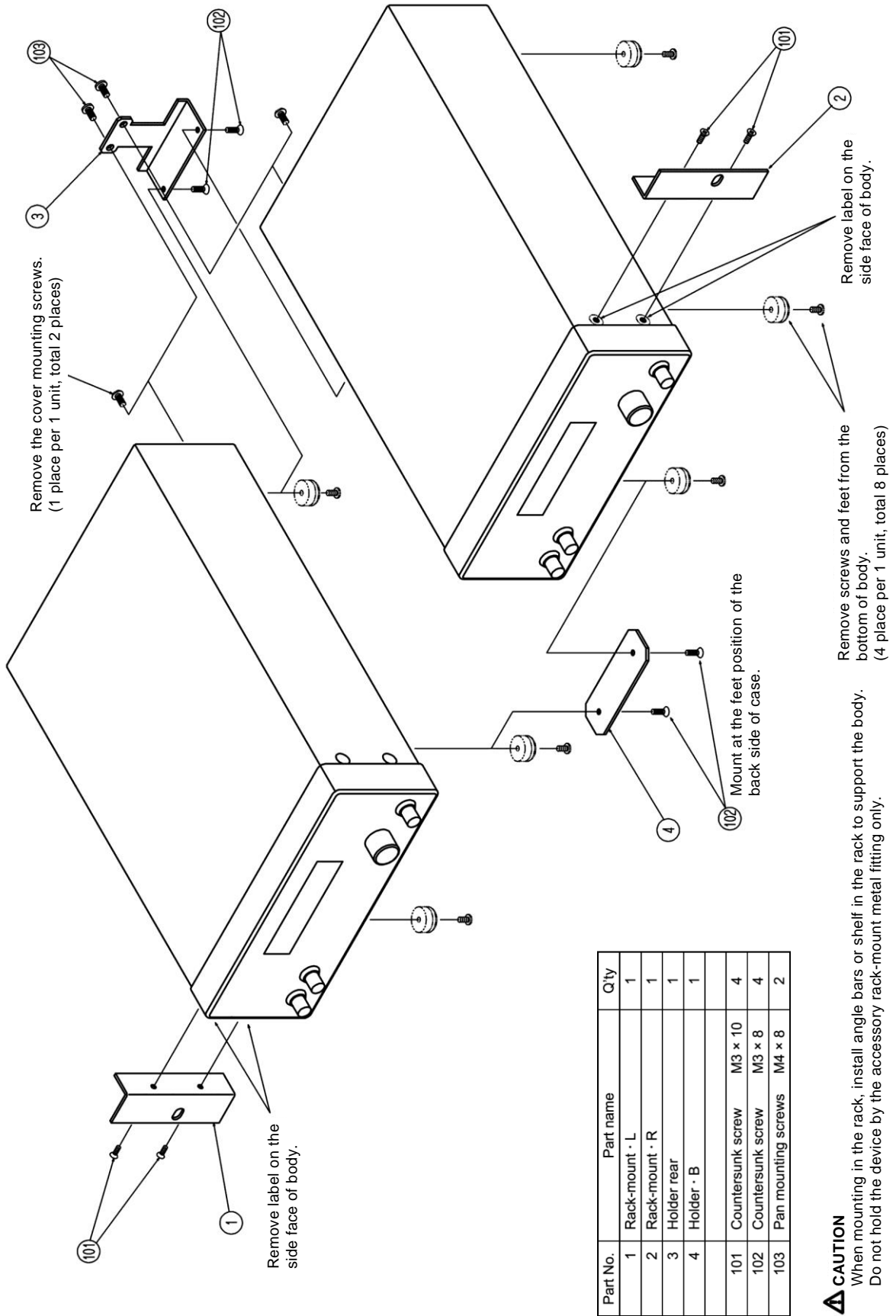
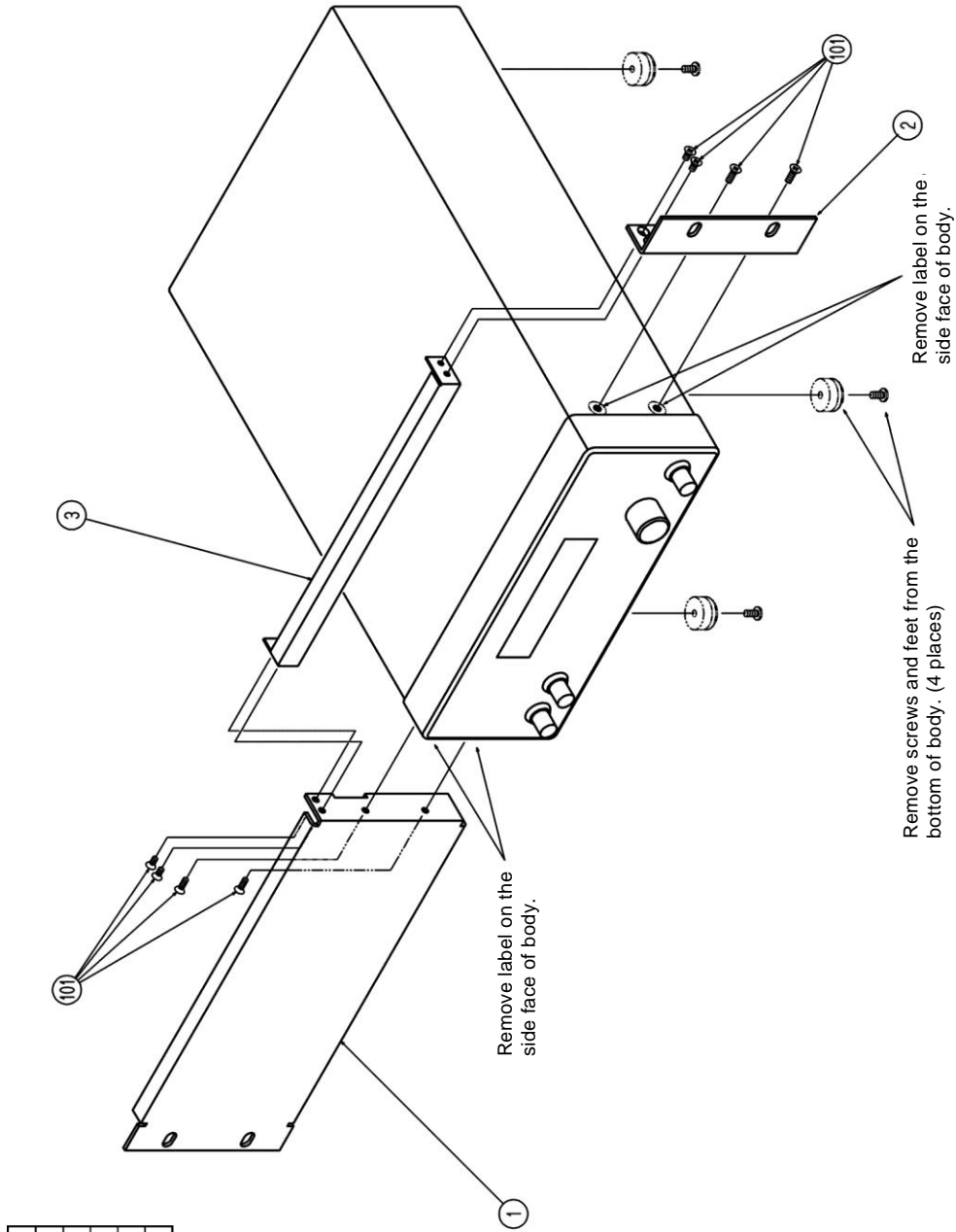

Figure 2-6 Assembly drawing of rack- mount kit (EIA, for 2 units)



Part No.	Part name	Qty
1	Rack-mount · BLK	1
2	Rack-mount · L	1
3	Rack-mount · spacer · 1	1
101	Countersunk screw M3 x 10	8

Figure 2-7 Assembly drawing of rack- mount kit (JIS, for 1 unit)

CAUTION
 When mounting in the rack, install angle bars or shelf on the rack to support the body.
 Do not hold the device by the accessory rack-mount metal fitting only.

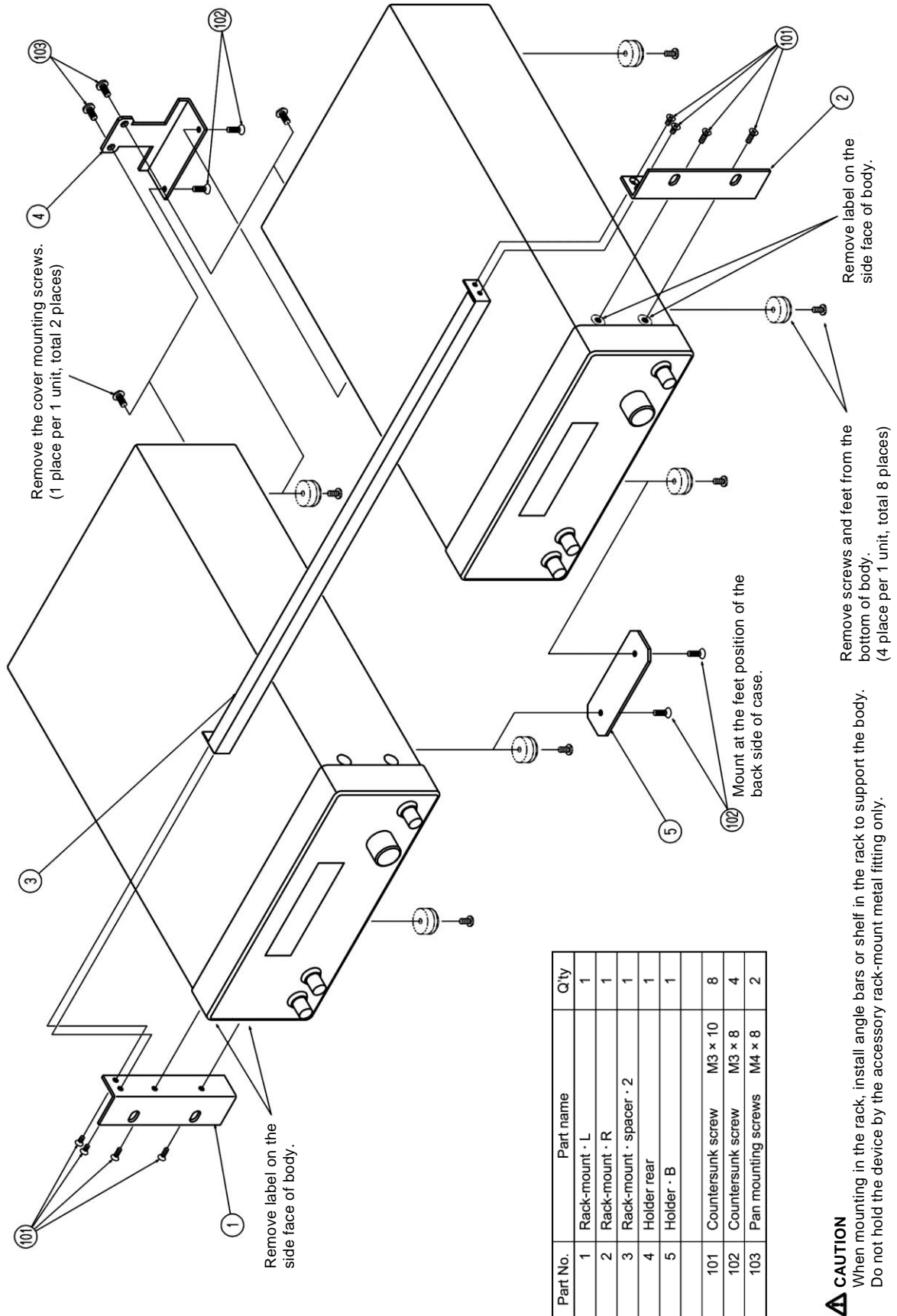

Figure 2-8 Assembly drawing of rack-mount kit (JIS, for 2 units)

2.3 Grounding and Power Supply Connection

■ Grounding

WARNING

Take the following precautions to avoid risk of electric shock.

Before connecting the device to the power supply, make sure the protective grounding terminal is grounded.

The protective grounding terminal for **CA5350** is the grounding pin of the three-pole power cord. Make sure you insert the power cord's plug into a three-pole power outlet with a protective grounding contact.

■ Power Supply

CA5350 operates with the following commercial power supply.

- Voltage range : AC 100V/120V/220V/240V ±10%, not exceeding 250VAC
(Select the voltage with the power voltage selector switch on the rear panel)
- Frequency range : 50 Hz/60 Hz ±2Hz
- Overvoltage category : II

Maximum power consumption is 40VA.

The power switch of **CA5350** is located on the rear panel.

Make sure that the power switch is set to OFF before connecting the power cord.

After powering off the device, make sure to wait for at least five seconds before powering on again.

The power code set can be used for disconnecting the product from AC power line in case of emergency.

WARNING

Maintain enough space around the inlet, to be able to remove the connector of a power cord from the inlet. Use a power socket located at convenient place with adequate space around so that the plug can be removed from socket.

■ Fuse

The rated fuse of **CA5350** is as follows:

100V, 120V: Time-lag 1A

220V, 240V: Time-lag 0.5A

As for both, rated voltage is 250V and size is $\phi 5.2 \times 20\text{mm}$.

WARNING

- Ensure that change settings of the voltage selector switch or replace the fuse after pulling over the power supply plug.
 - Only use the fuse that with specified capacity.
-

⚠ CAUTION

- Ensure that the power voltage selector switch is not in an invalid position. Set it to the point where you can hear a clicking sound.
 - Turn on the power after checking the setting of the power voltage selector switch.
 - Connect the power after checking that voltage of power socket is within the range of specified volage. Otherwise, it may damage **CA5350**.
 - The power cord supplied with this equipment is designed to be used for this equipment only. Do not use this power cord for other equipment or purposes.
-

2.4 Simplified Operation Check

This section explains the simplified operation check to be performance after storing the equipment for long time after purchasing.

For more detailed checking methods → Refer to “7. MAINTENANCE”.

2.4.1 Checking operation and display at power on

When power supply of **CA5350** is turned on, LCD will be initialized, startup screen will appear, and equipment will become operational.

- **For the display when power is turned.** → Refer to “3.2 Display at Power “ON” and Initial Setting”.
- **For the details of error message** → Refer to “6.1 Error Messages”.





WARNING

When there is smoke, odor, or sound from the device

Immediately pull out the power supply cord from the power socket, and do not use it unless the repair work is complete.

2.4.2 Checking key operation and response

With the following procedure, check that keys and knob are working correctly.

1. Without connecting anything to CURRENT INPUT connector of the front panel and the rear panel, connect the power supply. Turn on the power supply switch on the rear panel, and wait until the startup message disappears.
2. Press the **MENU** key to display the menu. Check that pressing the  key or the  key scrolls the menu displayed on LCD up and down.
3. Pressing the **ENTER** key when the **[GAIN]** menu is selected will display one lower hierarchy menu.
4. By pressing the  key and the  key, or operating of the knob, check that selection status of menu item changes.
5. Check that pressing the **EXIT** key returns to one higher hierarchy menu.

Thus, the simplified operation check is completed.

Finally, it is recommended to initialize the settings.

2.5 Calibration

Recommend that perform the Calibration for **CA5350** at least once a year, regardless of the use environment and use frequency.

When calibration is necessary, please contact NF Corporation or one of our representatives.

You will be liable for the costs of calibration or adjustment.

It is recommended to conduct a “**7.5 Performance Testing**” before using it for an important measurement or test.

If the performance test dose not produce satisfying results, NF Corporation will make the necessary adjustment or calibration to restore performance.

3. PANEL FEATURES AND BASIC OPERATIONS

- 3.1 Panel Component Names and Functions3-2
 - 3.1.1 Front panel3-2
 - 3.1.2 Rear panel.....3-3
- 3.2 Display at Power “ON” and Initial Setting3-4
 - 3.2.1 Display at Power “ON”3-4
 - 3.2.2 Initialization3-5
- 3.3 I/O Terminals3-6
- 3.4 I/O Connection3-9
 - 3.4.1 Connection of optical sensor, etc. (photodiode).....3-10
 - 3.4.2 Connection with lock-in amplifier,etc.....3-12
- 3.5 Operation Tree3-13
- 3.6 Basic Operation Examples3-15
 - 3.6.1 Basic Key Operations3-15
 - 3.6.2 Simplified Operating Method When You Use Device for the First Time.....3-17
 - 3.6.3 Initialization3-18
 - 3.6.4 Basic Settings3-19

3.1 Panel Component Names and Functions

This section describes the names and functions of the components on the front and rear panel of **CA5350**.

3.1.1 Front panel

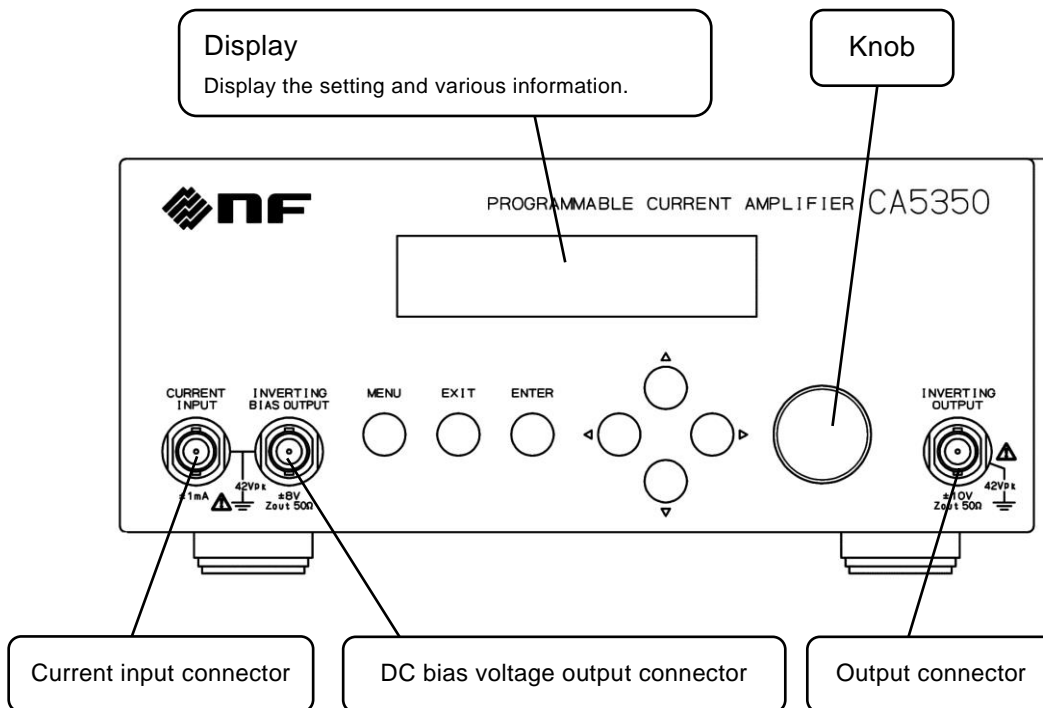

Figure 3-1 Front panel

● Operating keys and Knobs

- MENU : Display the top-level menu.
- EXIT : Abort setting, and display the one higher hierarchy menu.
- ENTER : Display the lower menu or confirm the setting items.
- ▲ ▼ : Scroll the menu or change the numerical value and setting items.
- ◀ ▶ : Select the setting change or displaying items.
- (Knob) : Change the numerical value and setting items.

3.1.2 Rear panel

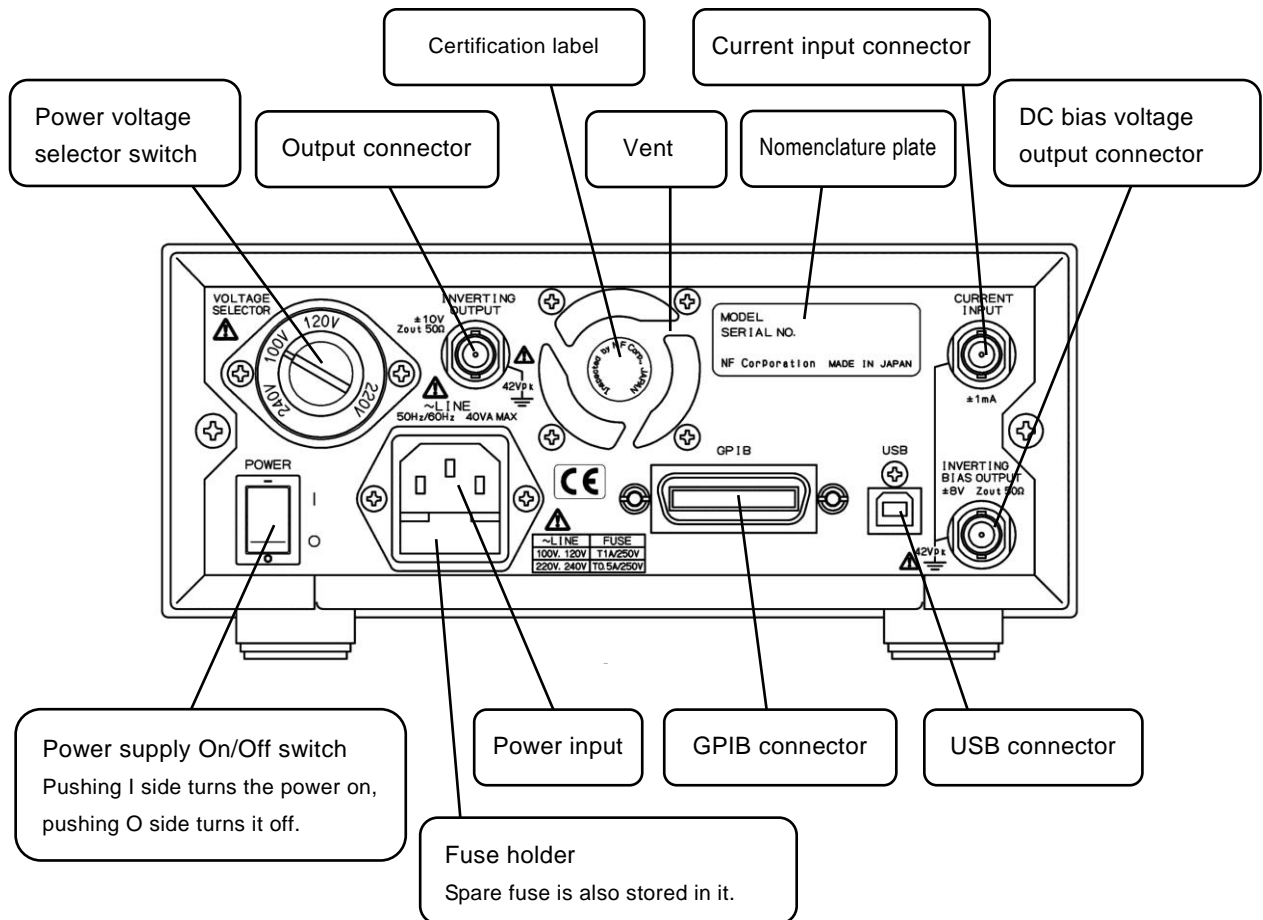

Figure 3-2 Rear panel

3.2 Display at Power “ON” and Initial Setting

3.2.1 Displays at Power “ON”

First, Take necessary preparation before usage/operation according to “2. PREPARATIONS BEFORE USE”.

When the power switch is turned on, a test pattern is displayed, and then a startup message including the model name “CA5350” and firmware version is displayed (see below).

Example:

CA5350	
Ver 1.00	2013/04/30
Version	Last adjustment date

After displaying this for about 1 second, self-check will be executed. When an error is found, the error message is displayed.

For details ⇒ “6.1.1 Errors at Power On”

If a serious error is found, the device will no longer operate with an error message displayed.

When setting are lost, an error message is displayed. However, it will initialize all setting of memory to the factory default values, and start the product.

Initialization contents ⇒ “3.2.2 Initialization”

When there is no error in the setting memory, it will be reset to the settings stored in memory number 1.

3.2.2 Initialization

CA5350 is reset to the factory default settings in the following cases:

- **At the time of shipment from factory**

All settings are initial values.

- **When setting in memory number 0 is recalled**

In setting memory No. 0, factory default settings are stored. However, the contents of setting memory No.1 ~ No.9 will not be changed.

- **When an abnormal error is found in the backup settings at power-on**

All setting memories (memory No. 1 ~ 9) are reset to the factory default state.

Table 3-1 Setting items and initial values list

Setting items	Parameter range	Initial values
<LCD adjustment>		
Backlight brightness	0, 1, 2	2
< Input select >		
Input select	FRONT, REAR	FRONT
<Gains>		
I/V Gain [V/A]	10k, 100k, 1M, 10M, 100M, 1G, 10G	10k
×10 Gain	×1, ×10	×1
<Filter>		
Filter	ON, OFF	ON
Auto filter	AUTO, MANUAL	AUTO
Rise time	1μs, 3μs, 10μs, 30μs, 100μs, 300μs, 1ms, 3ms, 10ms, 30ms, 100ms, 300ms	10μs
< Current suppression >		
Current suppression	ON, OFF	OFF
Range	±8nA, ±80nA, ±800nA, ±8μA, ±80μA, ±800μA	±800μA
Current	±(0~800.0μA)	000.0μA
<Voltage bias>		
Voltage bias	ON, OFF	OFF
Bias voltage	-8.000~+8.000V	0.000V
<Zero check>		
Zero check	ON, OFF	ON
<Remote control>		
GPIB address	0~30	2

3.3 I/O Terminals

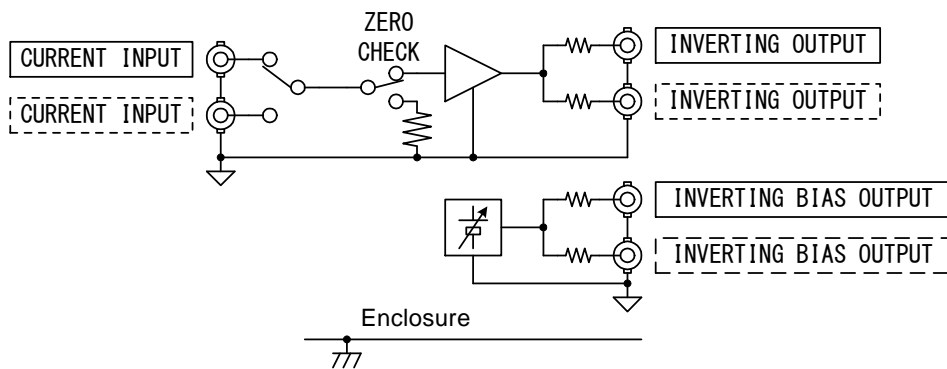

Figure 3-3 I/O Terminals

CURRENT INPUT, INVERTING OUTPUT, and INVERTING BIAS OUTPUT of **CA5350** are electrically insulated from the enclosure. Withstanding voltage is 42Vpk (DC + ACpeak).

⚠ WARNING

For avoiding electric shocks, ensure that voltage exceeding 42Vpk (DC+AC peak) should not be applied between the grounding of BNC connectors and enclosure.

If this voltage is exceeded over rated value, internal voltage limiter will become active and try to limit the voltage. However, if the applied voltage is too large, the product may get damaged.

⚠ CAUTION

Do not apply voltage to the output terminal. It may damage the product.

⚠ CAUTION

Do not apply current exceeding the maximum permissible value to the input terminal. It may damage the product.

⚠ CAUTION

When there is electric potential difference between the enclosure and the ground of BNC connector which is insulated from the enclosure, do not short-circuit the center pin of BNC connector and enclosure. It may damage the product.

■ Input terminal (CURRENT INPUT)

Input terminal of **CA5350** is located at two places, the front panel and the rear panel. Select and use either of them. You cannot use both input terminals simultaneously. Turning on ZERO CHECK will disconnect the input connector (the selected one from front and rear) from the internal amplifier. Use this when checking whether there is input current or offset of **CA5350** itself.

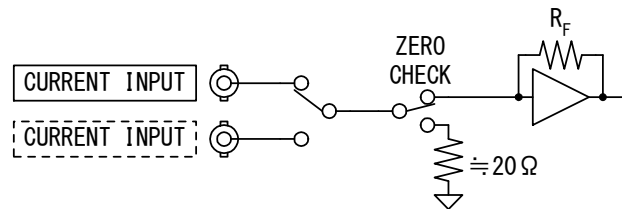

Figure 3-4 Input terminal

Method of select the input terminal ⇒ “3.6.4.1 Input select”

Remote command ⇒ “5.6 Description of individual command”, I Command

■ Output terminal (INVERTING OUTPUT)

Output terminal is provided in the front panel as well as the rear panel. Since output impedance is 50Ω for each terminal (supplementary value), when load current is flowing, the output voltage of each connector will differ even for the same output signal. Thus, it is recommended to use only one of output terminals, and keep the other one open. Maximum output current is $\pm 10\text{mA}$ as the total of both front panel and rear panel connectors.

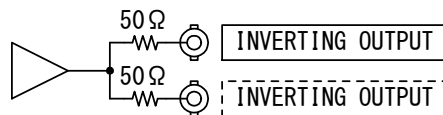

Figure 3-5 Output terminal

When a current signal is input to the input terminal of **CA5350**, a negative voltage will be output to the output terminal. And the output signal owns the opposite polarity of the input.

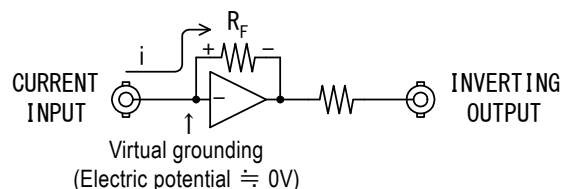

Figure 3-6 Output polarity

■ DC bias voltage output terminal (INVERTING BIAS OUTPUT)

This is the source of voltage bias for applying bias to the reverse bias type optical sensor (photo diode, etc).

It is provided in the front panel as well as the rear panel. Since output impedance is 50Ω for each terminal (supplementary value), when load current is flowing, the output voltage of each connector will differ even for the same output signal. Thus, it is recommended to use only one of output terminals, and keep the other one open. Maximum output current is $\pm 2\text{mA}$ as the total of both front panel and rear panel connectors.

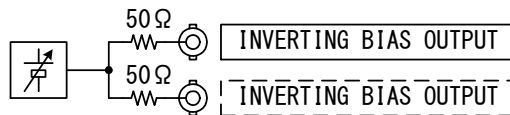

Figure 3-7 DC bias voltage output terminal

Voltage with the opposite polarity of DC bias voltage value set in **CA5350** will be output from INVERTING BIAS OUTPUT connector. For a typical connection with the sensor is made, the center pin of input connector (CURRENT INPUT) is considered as plus polarity, while the center pin of DC bias voltage output connector (INVERTING BIAS OUTPUT) applies minus bias voltage to the sensor.

For the connection with the sensor \Rightarrow “3.4.1 Connection with the optical sensor (photodiode, etc)”.

3.4 I/O Connection

To get the best low-noise performance of **CA5350**, it is important to shield the I/O terminals or connect/install the product rightly. Please do it as the following method.

- Install **CA5350** as close as possible to sensor or the source of signal, and keep the connection cable of CURRENT INPUT and INVERTING BIAS OUTPUT as short as possible.
- When there is an equipment with built-in transformers (both commercial power supply transformer or switching transformer) nearby, keep away the sensor and **CA5350** as far as possible. Besides, place the I/O cables of **CA5350** as far as possible.
- Make the product installed in a place of as little vibration as possible. When detecting weak signals, it may be affected by microphonic noise generated due to vibration of cables.
- For input and output, ensure to use shielded cables such as coaxial cables. Besides, ensure that input cable and DC bias voltage cable (CURRENT INPUT, INVERTING BIAS OUTPUT) should be separated from each other to avoid coupling. Coupling between input and output cables may cause instability such as self-oscillation.
- When using DC bias of **CA5350**, place the input cable (CURRENT INPUT) and DC bias cable (INVERTING BIAS OUTPUT) as close as possible. If the cables are apart, ground loop will be formed, and it will be easily affected by electromagnetic induction noise from external magnetic flux.

3.4.1 Connection of optical sensor, etc. (photodiode)

Ensure to place the sensor in a shield BOX.

(1) No-bias type sensor

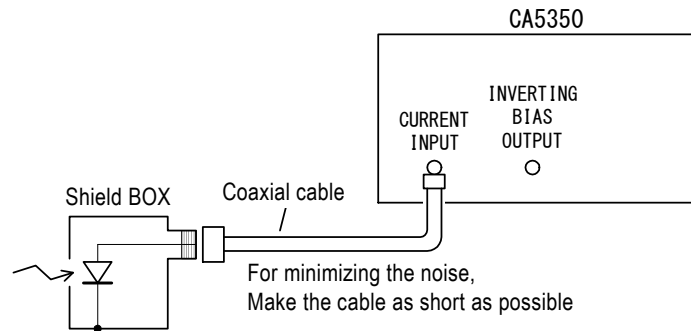

Figure 3-8 Connection of sensor without bias type

(2) Reverse bias type sensor

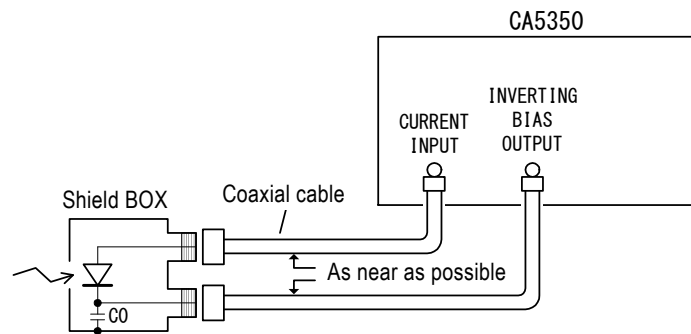

Figure 3-9 Connection of reverse bias type sensor

Keeping the DC bias voltage setting in **CA5350** is minus (0V or less) will apply reverse bias (plus to cathode, minus to anode) to the sensor shown in “**Figure 3-9 Connection of reverse bias type sensor**”.

C0 in “**Figure 3-9 Connection of reverse bias type sensor**” is the capacitor for bypassing the noise from outside, and use the capacitor with sufficiently large electrostatic capacitance when it is needed (for example: about 0.1 μ F).

Arrange the current input and bias output cable keeping it flat as much as possible. If the loop area formed with two cables become large, electromagnetic induction noise due to external magnetic flux will easily occur.

External DC voltage source can also be used as the bias voltage source for sensor. In that case, use sufficiently stable and low noise DC power.

When using a sensor with large dark current, it may cause the saturation of **CA5350**. It allows cancelling the dark current and getting larger gain by using current suppression function.

For the current suppression \Rightarrow “4.2 Cancelling the dark current of sensor”

(3) Example of connection with photomultiplier (PMT)

Because large bias voltage (hundreds of Volts) is required, dedicated power supply for bias voltage will be necessary.

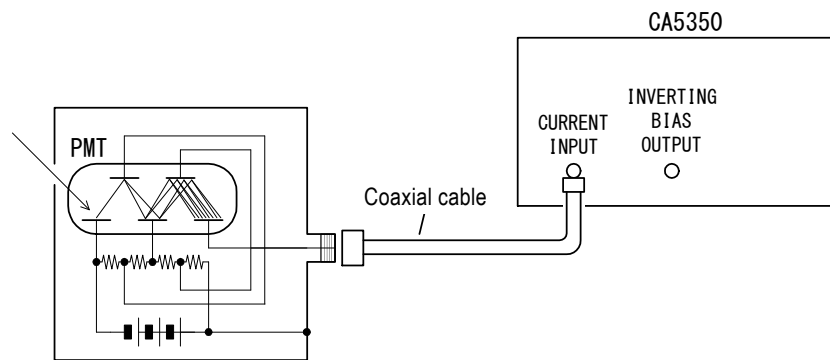

Figure 3-10 Example of connection with a photomultiplier

For either of connections, to get the best noise performance, it is important to make the input cable as short as possible.

3.4.2 Connection with lock-in amplifier, etc

When connecting the output (INVERTING OUTPUT) of **CA5350** to measurement equipment like a lock-in amplifier or a digitizer, it is necessary to pay attention to noise current due to ground loop.

Because I/O of **CA5350** is insulated from the enclosure, it is difficult to be affected by ground loop. However, it is necessary to pay careful attention to the grounding of equipments connected to the output of sensor or **CA5350**.

(1) When the single source is grounded

When the signal source is grounded, do not ground the input of measurement equipments (lock-in amplifier, etc.) those connected to the output of **CA5350**. Ground loop will be formed and noise current will flow, because of which the common mode noise may easily occur.

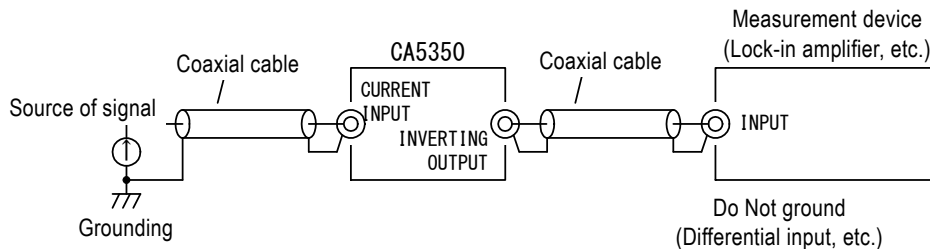

Figure 3-11 When the signal source is grounded

(2) When the signal source cannot be grounded

When the signal source cannot be grounded, as shown in “**Figure 3-12 When the signal source cannot be grounded**”, ground the shielded side of coaxial cable to the input of measurement equipment. If use the measurement equipment without grounding, high voltage will occur because of electrical charges accumulated in the shield of coaxial cable, which may cause electric shock or damage the machine. Besides, electrostatic induction may easily mix noise in the signal.

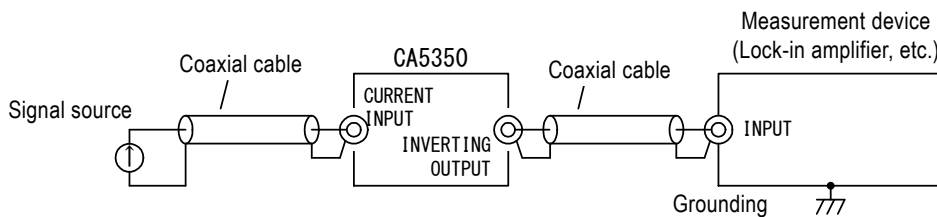
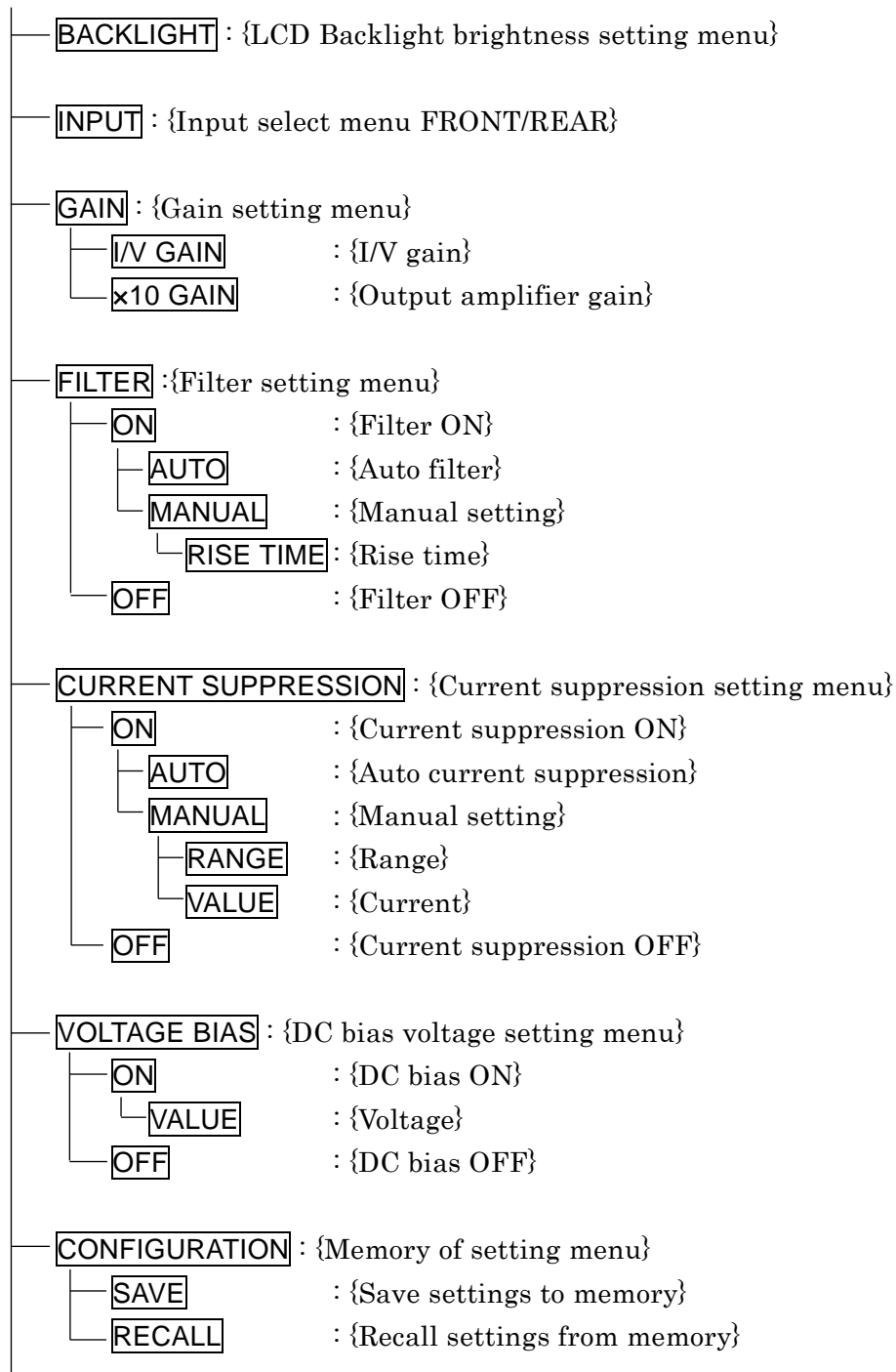

Figure 3-12 When the signal source cannot be grounded

3.5 Operation Tree

The operation tree when **CA5350** is operated from the panel is shown below.



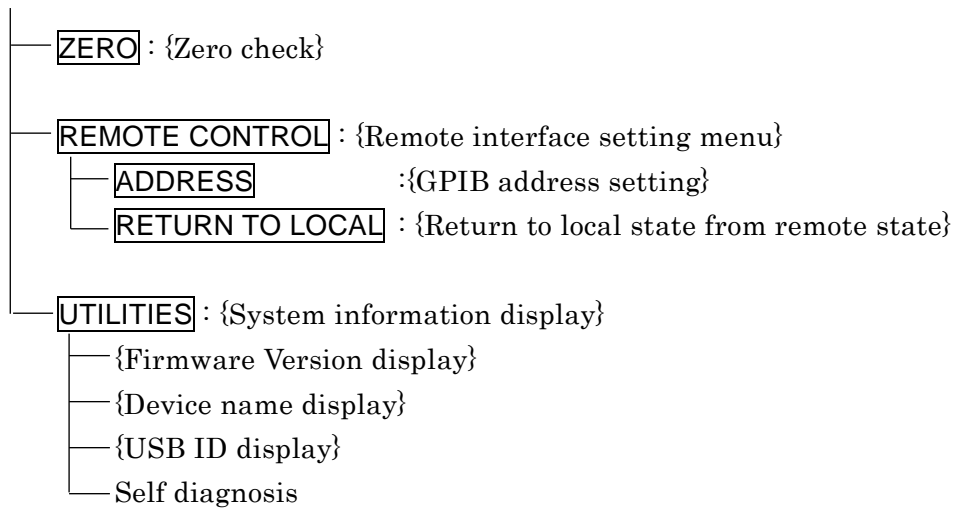

(Continued)



3.6 Basic Operation Examples

3.6.1 Basic Key Operations

For describing the operations, each key of panel is shown as below.

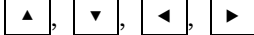
MENU Key 
 EXIT Key 
 ENTER Key 
 ▲ ▼ ◀ ▶ Key 

■ Displaying the top level menu

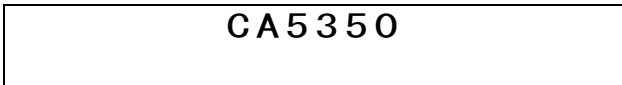

After turning on the power supply, the following top level menu will appear.





On the right side of screen, R indicating the remote status or I, O indicating the input over detected status may appear.

■ Menu Operation

• Menu Selection

In the top level menu, pressing the  key or rotating the knob in counterclockwise direction will show the following display. Even during various settings, pressing the  key will cancel the settings and display the menu. In the menu items currently selected, underline ‘_’ indicating cursor will be displayed under the first letter of menu.





By operating the ,  keys, or by rotating the knob, you can scroll the selected menu up and down.

• Execute the selecting menu

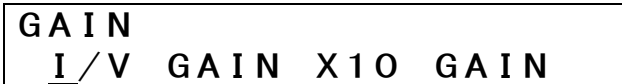

By pressing the  key, further lower hierarchy menu than the currently selected menu will be displayed. (secondary menu)

Example) When the secondary menu of the GAIN menu is displayed.





Pressing the  key will return to the one higher hierarchy menu. Repetitively pressing the  key will return the display to the top level menu.

■ Secondary Menu Selection



When there are several setting items in the lower hierarchy of menu, select the item using the ,  keys or knob, and press the **ENTER** key to display the lower level menu. Below the secondary menu, there may be items with third, fourth and lower hierarchy of menu.

Example) Secondary menu of the GAIN menu

```
GAIN
I / V GAIN X10 GAIN
```

GAIN menu has two secondary menus (I/V GAIN and ×10 GAIN), and they can be selected using the ,  keys or knob. Cursor will appear below the first letter of the selected item.

■ Change the Setting

By displaying the lowest level menu, you can change the setting. In the case of GAIN— I/V GAIN, 10k V/A, 100k V/A, ..., 10G V/A can be set, and presently set items will be displayed. Position of the cursor can be moved using the ,  keys or knob, but settings will not change unless the **ENTER** key is pressed. Pressing the **ENTER** key will confirm the settings. The word “Done” will appear for a short time after applying the settings.

Example) When I/V GAIN setting is 10k V/A

```
GAIN
I / V GAIN 10k V/A
```

When the ,  keys or knob is operated

```
GAIN
I / V GAIN 1G V/A
```





Although 1G V/A is displayed, the actual setting is 10k V/A as it is.

When the **ENTER** key is pressed,

```
GAIN
Done
```



“Done” will disappear after short time, and I/V GAIN will be set to 1G V/A.

■ Numerical value Input

When the cursor is on a parameter where numerical value can be set, value of the digit of cursor can be changed by operating the ,  keys or rotating the knob. Increase value using the  key or rotating the knob in clockwise direction, or decrease it using the  key or rotating the knob in counterclockwise direction.

Example) Setting of current suppression, current value

```
CURRENT SUPPRESSION
VALUE +19.34u A
```

In this state, operating the  key or rotating the knob in clockwise direction will increase the current value to +20.34μA, and operating the  key or rotating the knob in counterclockwise direction will decrease the current value to +18.34μA.

In the case of numerical value, the change will be applied even if the **ENTER** key is not pressed.

3.6.2 Simplified Operating Method When You Use Device for the First Time

This section describes the simplified operating method when you use the **CA5350** for the first time. Do not connect the remote control interface.

Operate as the following steps:

- 1) Initialize
- 2) Connected to the sensor (signal source)
- 3) Zero check OFF

The first step can be passed if the product is in the factory default setting.

■ Initialization

Turn on the power supply of **CA5350**. After initialization has completed, select the setting memory No. 0 from the menu CONFIGURATION-RECALL.

```

CONF I G U R A T I O N
R E C A L L  0
```

Reset to the factory default settings by pressing the **ENTER** key.

■ Connection with a sensor (or source of signal)

Connect the input connector (**CURRENT INPUT**) in the front panel of **CA5350** and sensor using a coaxial cable. In the factory default setting of **CA5350**, input is selected to **CURRENT INPUT** connector located on the front panel.

Similarly, connect the output connector (**INVERTING OUTPUT**) of **CA5350** and measurement equipment using a coaxial cable. Either front or rear output connector can be used.

Because **ZERO CHECK** of **CA5350** is still ON, signal from sensor has not been input to **CA5350**. Therefore, output voltage is almost 0V regardless of the sensor current.

■ Turning Zero Check to OFF

Select OFF from the Menu **ZERO CHECK**.

```

Z E R O   C H E C K
* O N   O F F
```

Press the **ENTER** key to turn OFF **ZERO CHECK**.

A voltage signal converted from the input current signal will be output to the output connector (**INVERTING OUTPUT**) of **CA5350**.

3.6.3 Initialization

There are two types of initialization as described below.

■ Initialization setting at Power ON

Select setting memory No. 1 from Menu- CONFIGURATION–RECALL, and press the **ENTER** key for reset to the settings at Power ON.

For **CA5350**, all settings will be reset as saved in memory No.1.

CA5350 will be automatically reset to the settings you saved to memory NO.1 last time after turning the power on.

■ Initialize to the factory default state

Select setting memory No. 0 from Menu- CONFIGURATION–RECALL, and press the **ENTER** key for resetting to the factory default settings. However, contents of memory No. 1 ~ 9 will not be changed.

Factory default state (Memory No. 0) cannot be changed.

For Details ⇒ “4.4 Saving/Recalling Settings in/from Memory”.

3.6.4 Basic Settings

3.6.4.1 Input select

Select either the front or rear connector (CURRENT INPUT) of **CA5350** for input. You can check and change the settings with MENU-INPUT.

```
INPUT
FRONT *REAR
```

The figure above shows input connector of the rear panel is selected. Moving the cursor to front or rear and pressing the **ENTER** key will set the connector selected with cursor as the signal input connector.

3.6.4.2 Zero Check

This function is for disconnecting input connector (CURRENT INPUT) signal from the internal amplifier. It is used for checking output offset of **CA5350** or whether there is current flowing from sensor.

You can check and change the settings from MENU-ZERO CHECK.

```
ZERO CHECK
*ON OFF
```

The figure above shows that in the current setting, ZERO CHECK is ON (input is disconnected from the internal amplifier). Select ON or OFF with cursor, and press the **ENTER** key to confirm the setting.

Turn ZERO CHECK OFF, when amplifying signal from the sensor. Note that it will not be amplified if the ZERO CHECK is ON.

3.6.4.3 Gain Setting

There are two types gain available in **CA5350**, namely I/V GAIN and $\times 10$ GAIN (the gain of output amplifier).

■ I/V GAIN Setting

This is the gain of current-to-voltage conversion. It can be set from Menu GAIN-I/V GAIN. The range is from 10k V/A (10^4) to 10G V/A (10^{10}).

```
GAIN
I/V GAIN 100k V/A
```

■ Output Amplifier Gain Setting

This is the gain of output amplifier, which is used for amplifying the voltage signal after the current-to-voltage conversion. Set from the Menu GAIN- $\times 10$ GAIN. Select either $\times 1$ or $\times 10$. The content with '*' mark on the left means the current setting.

```
GAIN
X10 GAIN X1 *X10
```

Normally, using $\times 1$ for $\times 10$ GAIN will give excellent noise characteristics. However, depending on the condition, keeping $\times 10$ GAIN as $\times 10$ may be beneficial.

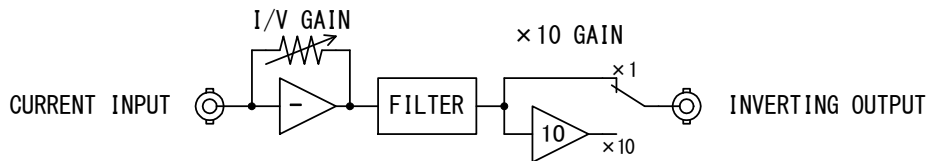

Figure 3-13 CA5350 outline block diagram

When SNR is very important for you, setting I/V GAIN as large as possible, and $\times 10$ GAIN (output amplifier gain) to $\times 1$ would help. When high speed response is needed, you can set output amplifier gain to $\times 10$, and set I/V GAIN to a low value.

3.6.4.4 Filter Setting

The equipment is equipped with filters for rejection a noise from input signal and improving the SNR. Filters characteristics have Bessel characteristics (2nd order) and it is of low-pass type. Overshoot does not occur in the pulse response, because of Bessel characteristics.

Filters are set in terms of rise time. Moreover, it is possible that filter is bypassed for getting the maximum speed and there is also an auto filter function that automatically sets the optimum filter with respect to I/V GAIN.

■ Using the filter

Select ON or OFF in the Menu FILTER.

```
FILTER
ON*OFF
```

In the above, the current setting is OFF, and cursor appears below ON. Pressing the **ENTER** key in this state will enable the filter.

Setting the filter to OFF (do not use) will disable the noise reject, but response properties will become fastest. When the fastest response is required, use it with the OFF state.

Filter rise time can be set with two methods, namely, manual setting method (MANUAL) and automatic setting method according to I/V GAIN (AUTO).

■ Manually setting the filter response (rise time)

Set from the Menu FILTER-ON-MANUAL-RISE TIME. Setting range is $1\mu\text{s} \sim 300\text{ms}$ and sequence is 1-3, and total 12 types of settings can be made.

```
FILTER
RISE TIME 100u s
```

Select the rise time with the **▲**, **▼** keys and knob, and press the **ENTER** key to apply the settings.

The larger (longer) the filter rise time is set, the smaller the bandwidth. Therefore, more noise components can be rejected, which will improve the SNR. However, response of signal will become slow, and original waveform information may be lost.

Set appropriate value according to the properties of the signal.

Any random filter setting can be made irrespective of I/V GAIN settings. However, overall response time of **CA5350** is the combination of the response of I/V GAIN and the response time fo filter. Generally, it will be decided by the one with longer response time.

■ Setting to Auto Filter

Selecting AUTO in the Menu FILTER-ON, AUTO will make filter settings corresponding to I/V GAIN settings irrespective of the filter rise time set in the MANUAL mode.

Table 3-2 I/V Gain Settings and Auto-Filter Settings

I/V Gain Settings (V/A)	Filter Settings
10G (10 ¹⁰)	100μs
1G (10 ⁹)	100μs
100M (10 ⁸)	30μs
10M (10 ⁷)	10μs
1M (10 ⁶)	10μs
100k (10 ⁵)	3μs
10k (10 ⁴)	1μs

Setting to auto filter will automatically change the filter settings when I/V GAIN settings are changed. Output amplifire gain setting is irrelevant.

(Reference material)

- About rise time

Rise time is defined as the time taken by output signal of **CA5350** to change from 10% to 90% of the amplitude of an ideal square-wave (rise time=0s) input signal.

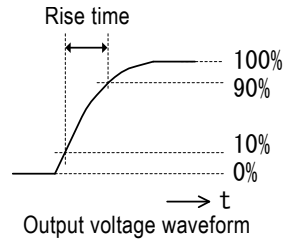

Figure 3-14 Definition of the rise time

Response of **CA5350** is affected by the rise time decided by filter as well as the response time of I/V amplifiers. When the rise time of I/V amplifier is t_{IV} and the rise time of filter is t_{FILT} , total rise time t_{TOTAL} can be approximated with the following expression.

$$t_{TOTAL} = \sqrt{t_{IV}^2 + t_{FILT}^2}$$

Rise time of I/V amplifier takes the following values according to I/V GAIN settings (supplementary values).

10G (10^{10}) V/A	$\doteq 25\mu\text{s}$
1G (10^9) V/A	$\doteq 5\mu\text{s}$
100M (10^8) V/A	$\doteq 2\mu\text{s}$
10M (10^7) V/A	$\doteq 1\mu\text{s}$
1M (10^6) ~ 10k (10^4) V/A	$\doteq 0.7\mu\text{s}$

When electrostatic capacitance of cables and sensor connected to current input terminal (CURRENT INPUT) becomes large, rise time of I/V amplifier will become large.

Larger (longer) is the rise time of I/V amplifier and filter, it will become closer to the total rise time of **CA5350**.

Example 1) When gain of I/V amplifier is 10G V/A (rise time $\doteq 25\mu\text{s}$) and filter setting is $1\mu\text{s}$,

$$t_{TOTAL} = \sqrt{t_{IV}^2 + t_{FILT}^2} = \sqrt{(25 \times 10^{-6})^2 + (1 \times 10^{-6})^2} \doteq 25\mu\text{s}$$

Example 2) When gain of I/V amplifier is 10G V/A (rise time $\doteq 25\mu\text{s}$) and filter setting is $30\mu\text{s}$,

$$t_{TOTAL} = \sqrt{t_{IV}^2 + t_{FILT}^2} = \sqrt{(25 \times 10^{-6})^2 + (30 \times 10^{-6})^2} \doteq 39\mu\text{s}$$

Example 3) When gain of I/V amplifier is 10G V/A (rise time $\doteq 25\mu\text{s}$) and filter setting is $300\mu\text{s}$,

$$t_{TOTAL} = \sqrt{t_{IV}^2 + t_{FILT}^2} = \sqrt{(25 \times 10^{-6})^2 + (300 \times 10^{-6})^2} \doteq 301\mu\text{s}$$

Even if the time set for filter is shorter than the rise time of I/V amplifier, responsiveness will not improve as mentioned above. Besides, noise will increase in high frequency range. Make appropriate filter settings according to gain of I/V amplifier, and response of the signal to be measures/detected.

- About settling time

Setting a large time for filter will reduce the noise, thereby improves the SNR of the signal. However, settling time will also become longer. Relation between the filter rise time and settling time is shown below (theoretical values).

Table 3-3 Filters' rise time and settling time

Filter setting	Settling time	
	10%	1%
1 μ s	1.19 μ s	1.70 μ s
3 μ s	3.57 μ s	5.11 μ s
10 μ s	11.9 μ s	17.0 μ s
30 μ s	35.7 μ s	51.1 μ s
100 μ s	119 μ s	170 μ s
300 μ s	357 μ s	511 μ s
1ms	1.19ms	1.70ms
3ms	3.57ms	5.11ms
10ms	11.9ms	17.0ms
30ms	35.7ms	51.1ms
100ms	119ms	170ms
300ms	357ms	511ms

- Relation with frequency characteristics

The longer the filter rise time is set, the narrower the frequency bandwidth will be. When high frequency component is required to be passed, set the filter to a small value. Relation between the filter rise time and -3dB cutoff frequency is shown below (theoretical values).

Table 3-4 Filters' rise time and bandwidth

Filter setting	-3dB cutoff frequency
1 μ s	340kHz
3 μ s	114kHz
10 μ s	34kHz
30 μ s	11.4kHz
100 μ s	3.4kHz
300 μ s	1.14kHz
1ms	340Hz
3ms	114Hz
10ms	34Hz
30ms	11.4Hz
100ms	3.4Hz
300ms	1.14Hz

4. ADVANCED OPERATIONS

4.1	Zero Check.....	4-2
4.2	Cancelling the dark current of sensor	4-3
4.2.1	Manually setting the current value to be cancelled	4-4
4.2.2	Automatically deciding the current value to be cancelled..	4-4
4.3	Setting DC Bias Voltage	4-6
4.4	Saving/Recalling the Settings.....	4-7
4.5	Self-diagnosis.....	4-8
4.6	Adjusting the LCD Backlight Brightness	4-9
4.7	Checking Various Information	4-10
4.7.1	Checking the Version.....	4-10
4.7.2	Checking the Production Number	4-10
4.7.3	Checking USB related ID.....	4-10

4.1 Zero Check

This function is used when checking offset of **CA5350**, or checking whether there is current flowing from sensor. Turning on zero check will disconnect the center pin of input connector (CURRENT INPUT) from the internal amplifiers in **CA5350**, and it will be connected to the shield terminal of CURRENT INPUT connector via a resistor about 20Ω .

Shown as **Figure4-1**, the load of sensor is kept as low impedance, and input of **CA5350** is turned off. By adjusting CURRENT SUPPRESSION (manual only) and turning the output voltage of **CA5350** to 0V, if ZERO CHECK is turned OFF, it will be possible to cancel the offset occurring in **CA5350**.

For the CURRENT SUPPRESSION ⇒ “4.2 Cancelling the dark current of sensor”

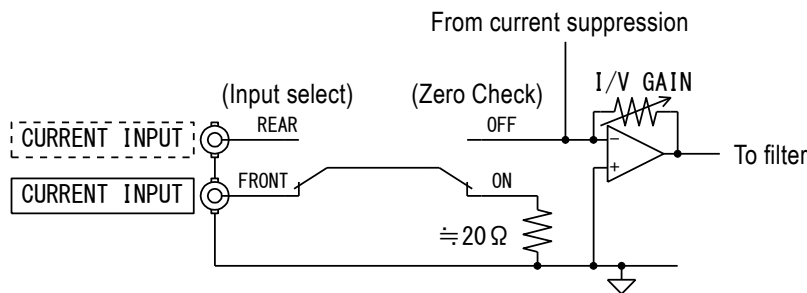

Figure 4-1 Input section circuit

Zero Check is set with Menu ZERO CHECK.

```

ZERO CHECK
*ON OFF
```

After selecting ON/OFF with the cursor keys , , you can apply the setting by pressing the key.

Note that if ZERO CHECK is ON, current from the sensor will not be amplified and output by **CA5350**. Be sure to turn ZERO CHECK to OFF when the input needs to be amplified.

4.2 Cancelling the dark current of sensor

It is equipped with current source for cancelling the dark current of sensor and for removing the offset component of **CA5350** itself. If the dark current of sensor is cancelled, gain of **CA5350** can be set to even larger value, and measurement sensitivity can be improved.

CURRENT SUPPRESSION is the variable current source connected to input terminal, and its setting range covers up to $\pm 800\mu\text{A}$ over 6 ranges. Each range has the setting resolution of ± 8000 .

Table 4-1 Current suppression setting range and resolution

Current Suppression	Setting Range	Setting Resolution
8nA range	-8.000nA ~ +8.000nA	0.001nA (1pA)
80nA range	-80.00nA ~ +80.00nA	0.01nA (10pA)
800nA range	-800.0nA ~ +800.0nA	0.1nA (100pA)
8 μA range	-8.000 μA ~ +8.000 μA	0.001 μA (1nA)
80 μA range	-80.00 μA ~ +80.00 μA	0.01 μA (10nA)
800 μA range	-800.0 μA ~ +800.0 μA	0.1 μA (100nA)

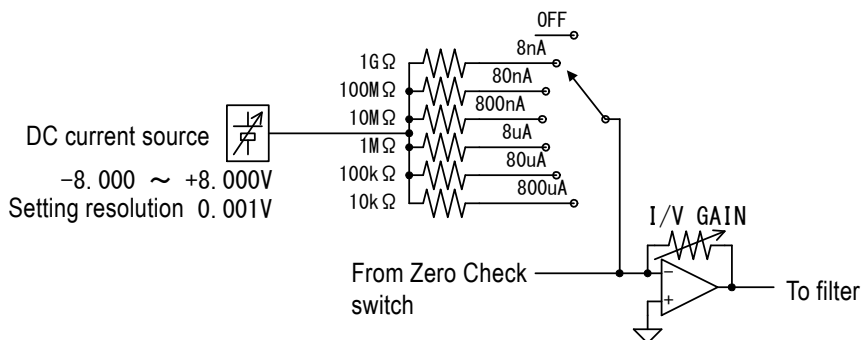

Figure 4-2 Block diagram of current suppression

Note that using the CURRENT SUPPRESSION function will increase noise in the output signal of **CA5350**. The bigger I/V gain or CURRENT SUPPRESSION value is, the higher the probability of introducing noise will be.

CURRENT SUPPRESSION settings include the MANUAL mode where range and current value are set manually, and the AUTO mode where current value and range required for making the output voltage of **CA5350** to 0V is selected automatically.

4.2.1 Manually setting the current value to be cancelled

■ Setting the range

Set from Menu CURRENT SUPPRESSION-ON-MANUAL-RANGE.

```
CURRENT SUPPRESSION
RANGE ±800uA
```

Select the range with , keys or knob, and apply by the key. Setting will not be changed unless the key is pressed. Setting range is available in 6 ranges of 8nA/80nA/800nA/8μA/80μA/800μA.

■ Setting the current value

Set from Menu CURRENT SUPPRESSION-ON-MANUAL-VALUE.

```
CURRENT SUPPRESSION
VALUE +800.0u A
```

The figure above is the example of 800μA range, and the underline cursor appears in the digit of 1μA. Numerical value of the digit selected with underline cursor can be increased or decreased in one step by pressing the , keys or rotating the knob. Changing the numerical value will immediately change the current.

4.2.2 Automatically deciding the current value to be cancelled

This function sets the range required for eliminating dark current from sensor and it automatically sets the current value. It is used when sensor is connected to the source of signal.

Auto suppression current will automatically renew the current value and range of CURRENT SUPPRESSION to the value selected through auto suppression current, and output voltage will be almost 0V. Current range and value set earlier will be lost. If settings need to be saved, be sure to save them in the setting memory before running auto current suppression.

For the saving the setting ⇒ “4.4 Saving/Recalling the Settings”

Select AUTO from the Menu CURRENT SUPPRESSION-ON, and press the key to run auto current suppression.

```
CURRENT SUPPRESSION
AUTO MANUAL
```

The following will appear on LCD when current value searched as a range.

```
CURRENT SUPPRESSION
AUTO SRCH
```

During auto current suppression, an irregular voltage with the value in range of -15 to 15V will be output to the output terminal of **CA5350**.

When auto current suppression is completed, message indicating the completion of process will appear for 1 second.

```
CURRENT SUPPRESSION
AUTO COMPLETE!
```

Current value and range of current suppression will be automatically renewed to the value selected by auto current suppression. Output voltage of **CA5350** is also almost 0V. After the above message appears, current suppression will not change automatically.

■ Precautions when running auto current suppression

• Turn OFF Zero Check.

Running auto current suppression with ZERO CHECK ON will show the following message and it will not run. Turn OFF ZERO CHECK.

For the Zero Check ⇒ “4.1 Zero Check”

```
CURRENT SUPPRESSION
AUTO Zchk ON
```

• When over input is detected, auto current suppression will not run.

If over input is detected in **CA5350** because of large I/V gain and large dark current of sensor, the following message will appear and auto current suppression will not run.

```
CURRENT SUPPRESSION
AUTO OVER
```

After making appropriate settings such as lowering I/V GAIN, change to the state where maximum input is not detected.

• During auto current suppression, ensure that input current does not fluctuate.

Fluctuation of current from sensor during auto suppression will result in process failure. The following message will appear for about 1 second after process failure. Current suppression setting (range, current value) will return to the settings when running auto current suppression.

```
CURRENT SUPPRESSION
AUTO ERROR
```

Even when the maximum range (800 μ A range) of current suppression is set and when the input current cannot be cancelled (current from sensor exceeds $\pm 800\mu$ A), the above message will appear.

Similarly, when a lot of noise is there in input current, process may fail.

Even if the above message not appearing, if input current fluctuates in auto current suppression or too much noise, output voltage of **CA5350** after completion of auto current suppression will largely deviate from 0V. As required, re-adjust the current suppression in the MANUAL mode.

4.3 Setting DC Bias Voltage

The device is equipped with the bias voltage source of maximum $\pm 8\text{V}/\pm 2\text{mA}$ capacity that can be used for sensor that required bias voltage.

For the connecting to sensors \Rightarrow “3.4 I/O Connection”

ON/OFF of DC bias voltage is set from the Menu VOLTAGE BIAS.

```
VOLTAGE BIAS
ON*OFF
```

Use the cursor keys , to select ON/OFF, and press the key for changing the settings.

Selecting ON will show the menu for setting the bias voltage value.

```
VOLTAGE BIAS
VALUE +2. 345 V
```

Setting range is $-8.000\text{V} \sim +8.000\text{V}$ and setting resolution is 0.001V (1mV). The above figure is an example where underline cursor is displayed below the digit of 0.1V.

Numerical value of the digit selected with underline cursor can be increased or decreased in one step by operating the , keys or by operating the knob. Changing the numerical value will immediately change the voltage.

In the bias output terminal (INVERTING BIAS OUTPUT), voltage of reversed polarity than the set voltage will be output. Electric potential of CURRENT INPUT is maintained almost 0V by current-to-voltage converter section. Therefore, the difference in electric potential applied to sensor will be same as the voltage set in DC bias voltage.

“Figure 4-3 Connecting to DC bias voltage” is electric potential and potential difference in electric potential of each part when DC bias voltage is set to $+1.2\text{V}$.

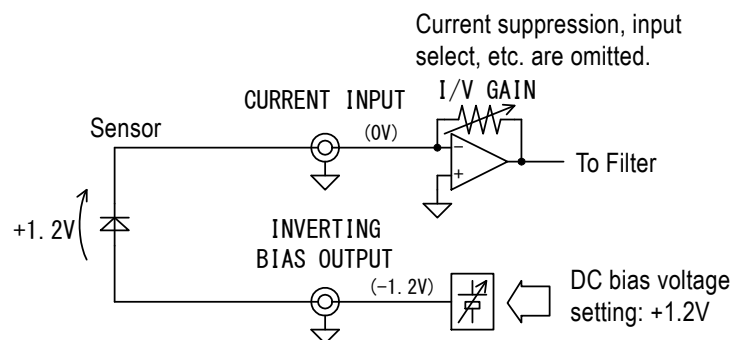

Figure 4-3 Connecting to DC bias voltage

4.4 Saving/Recalling the Settings

CA5350 can save and recall up to 10 sets of settings. In these 10 sets, one set is factory default settings and it cannot be changed.

■ Saving the setting in memory

Select the Menu CONFIGURATION–SAVE, and set the memory number to be saved.

```
CONF I G U R A T I O N
SAVE  3
```

Enter the memory number using the , keys or knob, and press the key. Settings cannot be saved until pressing the key. Settings in memory numbers 1 ~ 9 can be changed.

Memory number 0 cannot be overwritten, in which factory default settings are saved in advance.

Memory number 1 is especially used for saving the settings for the power-on initialization of **CA5350**. **CA5350** will recall the setting of memory number 1 automatically when turning on the power supply.

■ Recalling the setting saved in memory

Select the Menu CONFIGURATION–RECALL, and set the memory number to be recalled.

```
CONF I G U R A T I O N
RECALL 3
```

Enter the memory number using the , keys or knob, and press the key. Settings cannot be recalled until pressing the key. Memory numbers 0 ~ 9 can be set.

Recalling memory number 0 will return the factory default settings, However, contents of Memory numbers 1 ~ 9 are not changed.

Recalling memory number 1 will return the setting when power supply of **CA5350** is turned on.

4.5 Self -diagnosis

CA5350 is equipped with the function for conducting self-diagnosis.

This self-diagnosis is conducted automatically when power is turned on. You can also perform it at your discretion.

Select the Menu UTILITIES–SELF TEST, and press the **ENTER** key to start self-diagnosis.

```
UTILITIES
SELF TEST
```

The following display will appear during self-diagnosis. Second line of LCD shows the items being diagnosed. In the following figure, it shows that ROM test is being under progress.

```
CA5350
ROM TEST
```

Self-diagnosis usually completes within few seconds. If no error is found, a pass message will appear for short time and the display will return to the top menu. This diagnosis cannot be stopped once started.

When an error is found, the following messages will appear in the second line of LCD.

- ROM ERROR Error of the main memory (ROM) of microcontroller
- RAM ERROR Error of the main memory (RAM) of microcontroller
- NVRAM ERROR Error of nonvolatile memory where settings are saved in
- HARDWARE ERROR Overall circuit error

Out of the aforementioned error, when 'NVRAM ERROR' occurs, all setting memory numbers 1~9 are initialized to the factory default state (same contents as Memory No. 0), and the next self-diagnosis item will be conducted.

When errors other than "NVRAM ERROR" occur, **CA5350** will stop functioning at that point in time. Turn off the power supply of the rear panel, and restart the power supply. If error occurs again even after restarting the power supply, there is a possibility of malfunction of **CA5350**. Turn off the power switch, remove the power supply cord from the body, and contact NF Corporation or one of our representatives.

Self-diagnosis can only check fatal errors in the internal circuit. Small errors cannot be found. For increasing the reliability of measurements, it is recommended to conduct periodic check before starting the work. When conducting important measurements, it is recommended to conduct check both before and after the measurement.

4.6 Adjusting the LCD backlight Brightness

LCD backlight brightness of **CA5350** can be adjusted in 3 stages including off. Turn it off when light disturb the measurement, such as using in a dark room. Even it is turned off, if the surrounding area is somewhat bright, you can see the display of LCD.

Select the Menu **BACKLIGHT**, and select from 0 (backlight off) to 2(maximal). The bigger the numerical value is, the brighter the backlight is.

BACKLIGHT INTENSITY <u>2</u>

4.7 Checking Various Information

4.7.1 Checking the Version

Version of **CA5350** is displayed when turning on the power supply. Besides, it can also be checked from Menu UTILITIES–VERSION.

```
UTILITIES
VERSION 1.00
```

You can return to the previous menu by pressing the **EXIT** key.

4.7.2 Checking the Serial Number

You can check the serial number (differs by each device) of **CA5350** from Menu UTILITIES–IDENTIFICATION.

```
UTILITIES
ID 7654321
```

Serial number is a 7 digit numerical value. You can return to the previous menu by pressing the **EXIT** key.

4.7.3 Checking USB related ID

This is USB related ID of **CA5350** required when communicating with host PC using USB. It can be checked from Menu UTILITIES–USB.

```
UTILITIES
USB V : 0D34 P : 3B
```

V is Vendor ID (3402, decimal notation), and it is a number that shows NF Corporation. P is Product ID (59, decimal notation), and it shows the model **CA5350**.

You can return to the previous menu by pressing the **EXIT**.

5. REMOTE CONTROL

5.1	Preparations Before Use	5-2
5.1.1	Remote Control Interface Selection	5-2
5.1.2	Outline of USB	5-3
5.1.3	Outline of GPIB	5-4
5.1.4	Precautions on Communication	5-5
5.2	Switching between Remote State and Local State...	5-6
5.3	Response to Interface Message	5-7
5.4	Service Request and Status Byte	5-8
5.4.1	Service Request.....	5-8
5.4.2	Status Byte.....	5-8
5.5	Commands Explanation	5-9
5.6	Description of Individual Command	5-11
5.7	Multiline Interface Messages	5-22

5.1 Preparations Before Use

CA5350 can be remote controlled by USB or GPIB.

By sending command messages from the controller it is possible to control the device similarly as panel operations and receive the over state of **CA5350**.

The connectors of respective interface are located on the rear panel of the **CA5350**.

5.1.1 Remote Control Interface Selection

Either USB or GPIB can be used as an interface for remote control of **CA5350**. You cannot use both interfaces simultaneously. Accessing **CA5350** simultaneously from both interfaces will cause **CA5350** and host computer crashed, and you will have to reboot (turning on the power supply once again) them.

5.1.2 Outline of USB

5.1.2.1 Preparation of Controller

Prepare a personal computer equipped with the USB interface when using the USB interface.

Install the USB CDC driver in the computer that is used to control the product.

USB CDC: Universal Serial Bus Communication Device Class

It is possible to download the **CA5350** USB CDC driver install file from NF corporation web site.

<http://www.nfcorp.co.jp/>

5.1.2.2 Preparation of CA5350

For the USB interface, no setting is required in **CA5350**. USB related parameters can be found under the UTILITIES – USB and UTILITIES – IDENTIFICATION menus.

```
UTILITIES
USB V : 0D4A P : 3B
```

V : Vendor ID=0x0D4A (hexadecimal notation), 3402 (decimal notation): Which indicates NF Corporation.

P : Product ID=0x3B (hexadecimal notation), 59 (decimal notation): Which indicates product number of **CA5350**.

```
UTILITIES
ID 9083251
```

ID : Which indicates 7-digit serial number uniquely assigned to each product.

Press the **EXIT** key to return to the previous menu.

■ Message terminator

There is no program message terminator for receiving messages. LF and CR will be ignored.

Use Y Command to set the response message terminator.

5.1.2.3 USB Device Identification

Connect the **CA5350** to the USB connector of the computer using a generic USB cable. Connection via USB hub may result in an operation failure.

CA5350 is automatically identified by connecting it with USB to the computer on which USB CDC driver is installed.

The **CA5350** in the system is identified with the Vendor ID, Product ID, and Serial Number displayed on the UTILITIES menu. Use these values when specifying the device manually due to, for instance, automatic recognition error.

5.1.3 Outline of GPIB

The GPIB interface is designed to be used in favorable environment. Avoid the use in a place with much noise.

5.1.3.1 Preparation of Controller

Install generic GPIB card or controller board on the computer, and connect to the product with the GPIB cable. For the GPIB driver software, refer to the instruction manual of the GPIB card or controller board used.

5.1.3.2 Preparation of CA5350

For the GPIB, the device in the system is identified by the unique address. Set unique GPIB address for each equipment. The GPIB address of the **CA5350** is set through the procedure given below.

■ GPIB address setting

Select ADDRESS with the REMOTE menu, and the GPIB address setting menu as shown below is displayed.

REMOTE CONTROL ADDRESS 0 <u>2</u>

Press the **EXIT** key to return to one-previous menu.

■ Message terminator

There is no program message terminator for receiving commands. LF and CR will be ignored.

Use Y and K Command to set the response message terminator.

5.1.3.3 Precautions on Use of GPIB

- Connect or disconnect the GPIB connector with all devices connected to the bus turned off.
- Turn on the power of all devices connected to the bus when using the GPIB.
- The number of devices connectable to one bus via GPIB is maximum 15 units including the controller.
 - Total cable length $\leq (2\text{m} \times \text{Number of devices or } 20\text{m, the shorter one})$
 - Length of one cable $\leq 4\text{m}$
- For GPIB address, set a different value for each device. If plural devices with same address exist on one bus, the devices may be damaged due to the conflict of output.

5.1.3.4 Basic Specifications of GPIB

■ Interface functions

- SH1 Source Handshake full functions provided
- AH1 Acceptor Handshake full functions provided
- T6 Basic Talker, Serial Poll, and talker cancel function by listener-addressed provided
Talk-Only function not provided
- L4 Basic Listener function and listener cancel function by talker-addressed provided
Listen-Only function not provided
- SR1 Service Request full functions provided
- RL1 Remote Local full functions provided
- PP0 Parallel Poll function not provided
- DC1 Device Clear full functions provided
- DT0 Device Trigger function not provided
- C0 Controller function not provided
- E1 Open collector drive
- TE0 Extended talker function not provided
- LE0 Extended listener function not provided

5.1.4 Precautions on Communication

■ Input buffer

- Commands received are first stored in the input buffer, and then interpreted.
Input buffer size is 128 bytes. Ensure that do not send program message exceeding this size in one time.
- When an inappropriate command is received, it will result in error and program messages will be stopped executing before receiving X Command.

5.2 Switching between Remote State and Local State

In relation to the remote control, **CA5350** has the remote state and the local state. In the local state, all panel operations are enabled.

In the remote state, except the operations for backing to local and operations for changing LCD display to check current settings, operations of panel is disabled.

■ Selecting the remote state

Normally, the operation by USB or GPIB will make **CA5350** to the remote state.

■ Selecting the local state

From the front panel, select the REMOTE CONTROL – LOCAL menu, and press the **ENTER** key. With this, you can return from the remote state to the local state (except when local is locked out).

For GPIB interface, sending the GTL command from the controller or making REN line to a logical false, **CA5350** will be back to local. If the GPIB cable is disconnected, the REN line becomes false and **CA5350** will be back to local. Similarly, disconnecting the USB cable causes the product to be returned to the local state.

■ Disabling local operations from the panel

Local operating misses can be avoided by sending the local lockout (LLO) command from the controller. During the local lockout, the product will not return to the local state even if the LOCAL operation is applied.

However, the local state can be returned by the controller even in local lockout state.

■ USB

Send a command to the **CA5350**, and the **CA5350** becomes remote state.

By LOCAL operation, make the product to the local state.

The local lockout (LLO) function cannot be used.

REMOTE display

In the remote state, "R" on the LCD upper right is highlighted.



5.3 Response to Interface Message

Main responses to IEEE-488.1 interface messages are as listed below.

Table 5-1 Responses to interface messages

Message	Function
IFC	< InterFace Clear > Initializes the GPIB interface. Releases the specified listener and talker.
DCL,SDC	< Device CLear >, < Selected Device Clear > Clear the input and output buffers and return to the setting immediately after the power on.
LLO	< Local LockOut > Disables the transition from remote state to local state by the [LOCAL] operation on the panel. (only GPIB)
GTL	< Go To Local > Selects the local state (only GPIB)

As for how to send an interface message from the controller, it differs depending on the device driver. For details, refer to instruction manual of each driver.

5.4 Service Request and Status Byte

5.4.1 Service Request

Service Request (SRQ) is the function for setting the signal wire of SRQ of bus line to Low (=True) and allocating it to controller when issue of SRQ is permitted and CA5350 is in the following states.

- When input or output over is detected
- When a front panel key is pressed
- When ready for receiving the next command
- When an error has occurred

When controller detects SRQ of CA5350 and conducts serial polling, CA5350 will transfer the status byte of “5.4.2 Status Byte” to the controller, and withdraw SRQ. SRQ can be issued when its issue is permitted irrespective of the remote/local state.

5.4.2 Status Byte

Status Byte of CA5350 is as shown in “Table 5-2 Status Byte”.

Table 5-2 Status Byte

Bit	Contents	Conditions for set “1”	Conditions for reset “0”
(MSB)7	0	(Not used) 0 always	
6	RQS	• When SRQ is sent*1	• When DCL or SDC is received • After reading the status byte
5	Occurrence of error	• When an error has occurred	• After reading the error status*2
4	Ready for receiving commands	• When ready for receiving the next command	• When the an command is received*3
3	0	(Not used) Always 0	
2	0	(Not used) Always 0	
1	Key operation	• When a key of the front panel is operated	• After output of device information*4
(LSB)0	Over input detection	• When input over is detected	• When input over is no longer detected

*1: Only for GPIB. There is no SRQ for USB.

*2: After the output of response message of the "U1" command

*3: When "X" command is received

*4: After the output of response message of the "U0" command

5.5 Commands Explanation

Commands of **CA5350** are composed of one alphabet header and 0 ~ 2 parameters. When there is no parameter after the command, it will be interpreted as default parameters defined for that command.

■ Priority of command execution

Commands are stored in buffer in the sequence they are received. When 'X' command is received, commands in buffer are executed starting from the command with higher priority which is decided in “**Table 5-3 Priority of Execution of Commands**”.

Table 5-3 Priority of Execution of Commands

Priority	Command	Contents
1(High)	M	SRQ mask setting
2	K	EOI, X command hold off setting
3	A	LCD backlight brightness setting
4	I	Input select
5	R	Gain setting
6	W	Output amplifier gain setting
7	V	Voltage bias settings
8	B	Voltage bias, ON/OFF
9	T	Filter rise time setting
10	P	Filter, ON/OFF
11	Z	Auto-filter, ON/OFF
12	S	Current suppression setting
13	N0,N1	Current suppression, ON/OFF
14	C0,C1	Zero check, ON/OFF
15	N2	Auto current suppression
16	Y	Message terminator setting
17	J	Self-diagnosis execution
18	U	Information output
19	D	Message display on LCD
20	L	Save/Recall setting
21(Low)	H	Panel key input simulation

When there is error in any command in buffer, not only the command with error, but all commands until 'X' command will be discarded.

When commands need to be executed in the sequence as they were transferred, execution command 'X' should be added to the end of each command.

Example) LOXZOXM0X

■ Format of parameters

Format of parameter numerical value used either of NR1 (integer format), NR2 (fixed-point format), and NR3 (exponential).

- NR1 format Integer format

This format has no decimal point, and it considers that position of this decimal point is in the end of the final digit.

± DDDD

- ⊙ At the time of input, reading zero or space is ignored.
- ⊙ At the time of output, reading zero is space.
- ⊙ Sign is expressed with "+" and "-".
- ⊙ When omitted at the time of input, it is interpreted as "+". Number of overall digits is at user's discretion.
- ⊙ At the time of output, for some items, "+" may be shown with space. Constant value when the number of overall digits is decided according to the item.

Example: +01234

-500

18

- NR2 format Real number (fixed-point) format

It is a value that includes decimal point, and decimal point is shown with "." (period).

± DD.DD

- ⊙ At the time of input, reading zero or space is ignored. When number before the decimal point is omitted, numerical value of the integer part is interpreted as 0.
- ⊙ At the time of output, reading zero is space.
- ⊙ Sign is expressed with "+" and "-".
- ⊙ When omitted at the time of input, it is interpreted as "+". Number of overall digits is at user's discretion.
- ⊙ At the time of output, for some items, "+" may be shown with space. Constant value when the number of overall digits is decided according to the item.

Example: +012.34

-50.0

1.8

- NR3 format Real number (exponential) format

± DD.DDE± DD

- ⊙ This is exponential part.
- ⊙ At the time of input, reading zero or space is ignored. When number before the decimal point is omitted, numerical value of the integer part is interpreted as 0.
- ⊙ At the time of output, reading zero is space.
- ⊙ Same as NR2 format.

Example: +0.1234E+03

-50.0E-6

1.8E-9

5.6 Description of Individual Command

“Table 5-2 Header List” shows the list of headers for the commands of CA5350.

Table 5-4 Header List

Functions	Header	Description page
LCD Backlight Brightness Adjustment	A	5-12
Voltage Bias ON/OFF	B	5-12
Zero check ON/OFF	C	5-12
Message Display	D	5-12
Key Input	H	5-13
Input select	I	5-13
Self-Check execute	J	5-13
EOI, X Command Hold OFF Setting	K	5-14
Saving/Recalling Setting	L	5-14
SRQ Mask Setting	M	5-14
Current Suppression ON/OFF	N	5-15
Filter ON/OFF	P	5-15
I/V Gain Setting	R	5-15
Current Suppression Range and Current Setting	S	5-16
Filter Rise Time Setting	T	5-16
Status query		
Queries of Current Suppression Setting	U	5-17
Queries of CA5350 Setting	U0	5-18
Queries of Error Status	U1	5-19
Queries of Bias Voltage	U2	5-20
Queries of Total Gain	U3	5-20
Queries of Model Name and Firmware Version	U4	5-20
Voltage Bias Setting	V	5-20
Output Amplifier Gain $\times 1/\times 10$	W	5-20
Command Execution	X	5-20
Message Terminator Setting	Y	5-21
Auto filter ON/OFF	Z	5-21

■ A – LCD Backlight Brightness Adjustment

Description: Adjustment of LCD backlight brightness
 Setting: A0 Maximum brightness (factory default setting)
 A1 Intermediate brightness
 A2 Backlight OFF
 Remarks: Control the LCD backlight brightness of front panel.

■ B – Voltage Bias

Description: Bias Voltage ON, OFF
 Setting: B0 Voltage Bias OFF (factory default setting)
 B1 Voltage Bias ON
 Remarks: Controls the voltage bias output of INVERTING BIAS OUTPUT connector. Output voltage is set with V command.

■ C – Zero Check

Description: Zero Check function ON, OFF
 Setting: C0 Zero Check OFF
 C1 Zero Check ON (factory default setting)
 Remarks: Turning ON Zero Check will disconnect the CURRENT INPUT connector in the internal circuit, and it will be shunted at about 20Ω to the external cover (shield) of the CURRENT INPUT connector. This function is used for checking whether there is current flowing from sensor or not. When amplifying the sensor current, set Zero Check to OFF (C0). CURRENT INPUT connector is located on the front panel and the rear panel. Use I command to set the panel to be used.

■ D – Message Display

Description: Display of message string on LCD
 Setting: Daaa...aX Character string aaa...a is displayed on the 2nd line of LCD
 DX Return to normal display (factory default settings, settings when power is turned on)
 Remarks: Sets the character string to be displayed on the 2nd line of LCD. Up to 20 characters can be set. When the character string is less than 20 characters long, the remaining spaces will be filled with blank. When the string exceeds 20 characters, only first 20 characters will be displayed. Following display is possible characters.
 !"#%&'()*+,-./
 0123456789:;<=>?
 @ABCDEFGHIJKLMNPQRSTUVWXYZ[\]^_
 `abcdefghijklmnopqrstuvwyz{|}~
 (blank)

■ H – Key Input

Description: Key Input

Setting: H14 ◀
 H15 ▶
 H16 (Left rotation of knob)
 H17 (Right rotation of knob)
 H18 ▲
 H19 ▼
 H20 EXIT
 H21 ENTER
 H22 MENU

Remarks: This will perform the same processes as pressing the front panel keys of **CA5350**. For parameters other than above, it will result in error.

■ I – Input select

Description: Input connector select

Setting: I0 Use the input connector located on the front panel (factory default settings)
 I1 Use the input connector located on the rear panel

Remarks: Select the current input connectors of **CA5350**.

■ J – Self-Check execute

Description: Self-check execute.

Setting: J0 Perform memory test
 J1 Perform memory test and LCD display test

Remarks: It will perform similar tests as conducted when turning on the power supply. If error is detected, error message will appear on LCD. Besides, results of memory test can be queries with U1 command. For the details of the test contents, refer to “**3.2 Display at Power “ON” and Initial Setting**”.

■ K – EOI, X Command Hold OFF Setting

Description:	EOI setting	
Setting:	K0	EOI enabled, X command hold off enabled (factory default settings)
	K1	EOI disabled, X command hold off enabled
	K2	EOI enabled, X command hold off disabled
	K3	EOI disabled, X command hold off disabled
Remarks:	<p>This function is enabled only for GPIB. It is not related to USB.</p> <p>It sets whether to append EOI in the beginning of the message or not when CA5350 responds a message to controller. When CA5350 receives a command, EOI is ignored irrespective of the settings of K command.</p> <p>Enabling X command hold off will hold the bus at the time when the X command is received (without returning NRFD line to high), and it will stop receiving the following command. After running a set of commands until X command, the following commands will be executed after returning NRFD to high.</p>	

■ L – Saving/Recalling Setting

Description:	For saving and recalling the settings	
Setting:	L0	Return the settings of CA5350 and memory No. 1 to factory default settings
	L1	Copy the existing CA5350 settings into memory No. 1
	L2	Return the settings of CA5350 to the settings when power was turned on (Memory No. 1)
	L102 ~ L109	Copy the existing CA5350 settings into memory No.2 ~ No.9
	L202 ~ L209	Recall the settings of Memory No.2 ~ No.9
Remarks:	<p>In the setting memory of CA5350, there is factory default setting (Memory No. 0), setting when turning on the power supply (Memory No. 1), and Memory No.2 ~ No.9. Factory default settings cannot be changed. For the details of the memory, refer to “4.4 Saving/Recalling the Setting into the Memory”.</p>	

■ M – SRQ Mask Setting

Description:	Setting of SRQ mask	
Setting:	Mn	n is a 8 bit numerical value (0~255)
	bit0	1 means SRQ issued during the I/O over is detected
	bit1	1 means SRQ issued when a front panel key is pressed
	bit2	Not used
	bit3	Not used
	bit4	1 means SRQ issued when CA5350 is ready for receiving commands
	bit5	1 means SRQ issued when an error occurred
	bit6	Not used
	bit7	Not used
Remarks:	<p>When more than one reason occurred causing mask bit be 1, CA5350 will send SRQ to controller. This function is only for GPIB, and it cannot be used with USB.</p>	

■ N – Current Suppression ON/OFF

Description: ON, OFF setting of current suppression

Setting: N0 Current suppression OFF (factory default setting)
 N1 Current suppression ON
 N2 Auto current suppression starts

Remarks: Current value when turned on is set with S command.
 When performing auto current suppression (N2), Zero Check must be Off (C0). For the details of the current suppression, refer to “**4.2 Cancelling the dark current of sensor**”.

■ P – Filter ON/OFF

Description: ON, OFF setting of filter

Setting: P0 Filter OFF (factory default setting)
 P1 Filter ON

Remarks: Set filter rise time using T Command with filter ON.

■ R – I/V Gain Setting

Description: Setting of I/V gain

Setting: R4 10k (=10⁴) V/A (factory default setting)
 R5 100k (=10⁵) V/A
 R6 1M (=10⁶) V/A
 R7 10M (=10⁷) V/A
 R8 100M (=10⁸) V/A
 R9 1G (=10⁹) V/A
 R10 10G (=10¹⁰) V/A

Remarks: Gains can be set as above only when the output amplifier gain is ×1.
 When output amplifier gain is set to ×10, total gain will be 10 times of the value set by this command.
 Settings except the above will cause error.

■ S – Current Suppression Range and Value Setting

Description:	Settings of range and current value of current suppression
Setting:	<p>Sv,0 Auto range</p> <p>Sv,1 $\pm 8\text{nA}$ range, 1pA resolution</p> <p>Sv,2 $\pm 80\text{nA}$ range, 10pA resolution</p> <p>Sv,3 $\pm 800\text{nA}$ range, 100pA resolution</p> <p>Sv,4 $\pm 8\mu\text{A}$ range, 1nA resolution</p> <p>Sv,5 $\pm 80\mu\text{A}$ range, 10nA resolution</p> <p>Sv,6 $\pm 800\mu\text{A}$ range, 100nA resolution (factory default setting S0,6)</p> <p>S,10 Abort running auto range</p>
Remarks:	<p>The first parameter v indicates current value (unit: A), while second parameter (0 ~ 6) indicates range to be set.</p> <p>Setting a value that is out of the range to v will result in error.</p> <p>Setting any number except the above to the second parameter will result in error.</p> <p>Setting to auto range (Sv,0) will ignore the range setting (Sv,1 ~ Sv,6) of current suppression until auto range is released (S,10), and the optimum range having maximum resolutions will be automatically found and set.</p> <p>Current suppression range and value will be same as the time when Auto Current Suppression was aborted.</p>

■ T – Filter Rise Time Setting

Description:	Filter rise time setting
Setting:	<p>T. 1μs</p> <p>T/ 3μs</p> <p>T0 10μs (factory default setting)</p> <p>T1 30μs</p> <p>T2 100μs</p> <p>T3 300μs</p> <p>T4 1ms</p> <p>T5 3ms</p> <p>T6 10ms</p> <p>T7 30ms</p> <p>T8 100ms</p> <p>T9 300ms</p>
Remarks:	Filter is set to ON/OFF with P Command.

■ U – Queries of Current Suppression Setting

Description: Send the current suppression setting value to the controller. Even if current suppression is OFF, current suppression value set using S command will be output.

Response message:

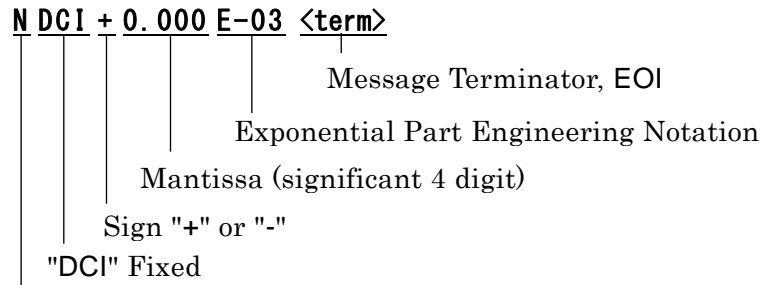

Status "N": Normal, "O": Over

Exponential part and mantissa of response message show the following according to the current suppression range.

Range	Mantissa	Exponential Part
± 8nA range	0.000	E-09
± 80nA range	00.00	E-09
± 800nA range	000.0	E-09
± 8µA range	0.000	E-06
± 80µA range	00.00	E-06
± 800µA range	000.0	E-06

Remarks: For message terminator refer to Y command, and for EOI refer to K command.

■U0 – Queries of CA5350 Setting

Description: Output for the **CA5350** setting.

Response message:

CA5350	A0	B0	C0	H21	I0	J0	K0	M001	N2	P1	R09	S0	5 T.	W0	Y3	Z0	<term>	
(1)	(2)	(3)	(4)	(5)	(6)	(7)	(8)	(9)	(10)	(11)	(12)	(13)	(14)	(15)	(16)	(17)	(18)	(19)

- | | | |
|------|---|---------------------------|
| (1) | Device model " CA5350 " Fixed | |
| (2) | LCD backlight brightness | Refer to A command |
| (3) | Bias voltage ON, OFF | Refer to B command |
| (4) | Zero Check ON, OFF | Refer to C command |
| (5) | Key last pressed | Refer to H command |
| (6) | Input connector Front, Rear | Refer to I command |
| (7) | Self-check results | |
| | 0 : Passed the check | |
| | 1 : ROM error | |
| | 2 : RAM error | |
| | 3 : ROM error and RAM error | |
| | 4 : NVRAM error | |
| (8) | EOI and X Command Hold OFF Setting | Refer to K command |
| (9) | SRQ mask | Refer to M command |
| (10) | Current suppression ON, OFF | Refer to N command |
| (11) | Filter ON, OFF | Refer to P command |
| (12) | I/V gain | Refer to R command |
| (13) | Auto Current Suppression | |
| | 0 : Auto OFF (manual) | |
| | 1 : Auto ON | |
| (14) | Current Suppression range | Refer to S command |
| | When in Auto mode, range that is actually set will be output. | |
| (15) | Filter setting | Refer to T command |
| (16) | Output amplifier gain setting | Refer to W command |
| (17) | Message terminator | Refer to Y command |
| (18) | Auto filter ON, OFF | Refer to Z command |

Remarks: Meanings of numerical value match with the corresponding remote control parameters. Refer to the description of each command for more details.

■ Y – Message Terminator Setting

Description: Setting of message terminator

Setting: Y0 CR, LF (factory default setting)

Y1 LF, CR

Y2 CR

Y3 LF

Remarks: Sets the message terminator when response message is output with the Un command. There is no terminator when receiving the command. When a command is received, CR, LF, and EOI will also be read and discarded.

■ Z – Auto Filter ON/OFF

Description: Auto filter setting

Setting: Z0 Auto Filter ON

Z1 Auto Filter OFF (factory default setting)

Remarks: Turning ON the auto filter will automatically set the filter according to I/V gain settings irrespective of the filter settings made with T command. For details, refer to "3.6.4.3 Filter Setting".

5.7 Multiline Interface Messages

*2					b7	*1	0	0	0	0	0	0	1	1	1	1	1		
					b6	MSG	MSG	MSG	MSG	MSG	MSG	MSG	MSG	MSG	MSG	MSG	MSG		
					b5	0	1	0	1	0	1	0	1	0	1	0	1		
b4	b3	b2	b1	Column	0	1	2	3	4	5	6	7							
Row					0														
0	0	0	0	0	NUL		DLE	SP	↑	0	↑	@	↑	P	↑	`	↑	p	↑
0	0	0	1	1	SOH	GTL	DC1	LLO	!	1		A		Q		a		q	
0	0	1	0	2	STX		DC2	"		2		B		R		b		r	
0	0	1	1	3	ETX		DC3	#		3		C		S		c		s	
0	1	0	0	4	EOT	SDC	DC4	DCL	\$	4		D		T		d		t	
0	1	0	1	5	ENQ	*3 PPC	NAK	PPU	%	5		E		U		e		u	
0	1	1	0	6	ACK		SYN	&		6		F		V		f		v	
0	1	1	1	7	BEL		ETB	'		7		G		W		g		w	
1	0	0	0	8	BS	GET	CAN	SPE	(8		H		X		h		x	
1	0	0	1	9	HT	TCT	EM	SPD)	9		I		Y		i		y	
1	0	1	0	10	LF		SUB	*		:		J		Z		j		z	
1	0	1	1	11	VT		ESC	+		;		K		[k		{	
1	1	0	0	12	FF		FS	,		<		L		\		l			
1	1	0	1	13	CR		GS	-		=		M]		m		}	
1	1	1	0	14	SO		RS	.		>		N		^		n		~	
1	1	1	1	15	SI		US	/		?	UNL	O		_	UNT	o		DEL	

Address Command Group (ACG)

Universal Command Group (UCG)

Listener Address Group (LAG)

Talker Address Group (TAG)

Primary Command Group (PCG)

Secondary Command Group (SCG)

Note: *1 MSG is Interface message
 *2 b1=DIO1....b7=DIO7. DIO8 is not used
 *3 Follows by a secondary command

GTL : Go To Local
 SDC : Selected Device Clear
 PPC : Parallel Poll Configure
 GET : Group Execute Trigger

TCT : Take Control
 LLO : Local Lockout
 DCL : Device Clear
 PPU : Parallel Poll Unconfigure
 SPE : Serial Poll Enable
 SPD : Serial Poll Disable
 UNL : Unlisten
 UNT : Untalk

6. TROUBLESHOOTING

6.1	Error Messages.....	6-2
6.1.1	Errors at Power ON.....	6-2
6.1.2	Errors at Panel Operation.....	6-3
6.1.3	Error during Operation.....	6-3
6.1.4	Errors in Remote Control.....	6-3
6.2	When the Device Appears to be a Problem.....	6-4

6.1 Error Messages

An error in the self-diagnosis at the power on or a failure in the panel operation or remote control causes an error message to be displayed.

This chapter describes the content, cause, and corrective action of main error messages. When the repair is required, please contact NF Corporation or one of our representatives.

When you request the repair of **CA5350**, please let us know the content of an error message if it is displayed. An error message not listed in this instruction manual may be displayed due to a malfunction caused by strong external noise.

A special message not listed here may be displayed, for instance, when the firmware is updated. If other manual are supplied, refer to such manual.

6.1.1 Errors at Power ON

At the power on, the self-diagnosis is conducted and if an error is found, an error message as listed below is displayed on the LCD.

Table 6-1 Error message list at Power ON

Error message	Content and Cause	Corrective action
ROM ERROR	Internal memory (ROM) error	Turn off the power once, and turn it on again.
RAM ERROR	Internal memory (RAM) error	
NVRAM1 ERROR	Correction values have been lost. An error is found in the contents of the calibration data memory. • Defective memory	If the error occurs again, the device is defective, requiring the repair. If either of these errors is detected, the error message is kept displayed, and the device cannot proceed to usual operation.
HARDWARE ERROR	Hardware error	
NVRAM2 ERROR	Settings have been lost. An error is found in the contents of the setting memory. • Defective memory • Temporary failure due to power off, etc. during setting change	Re-set the lost data. When lost is detected, contents will initialize to the factory default settings, and the device will proceed to usual operation. If this error message is displayed every time when the power is turned on, the device is defective, requiring the repair.

6.1.2 Errors at Panel Operation

Main errors due to the panel operation are as listed below.

Table 6-2 List of error messages when operating the panel

Error message	Content and Cause	Corrective action
AUTO OVER	Auto current suppression failed. • Over input detected.	Revise the settings of I/V gain and voltage bias, and make changes so that over input is not detected.
AUTO Zchk ON	Auto current suppression failed. • Zero Check is ON	Turn OFF Zero Check.
AUTO ERROR	Auto current suppression failed • Large variation in input current. • Input current exceeds $\pm 800\mu\text{A}$.	Manually set the suppression current value. Set the input current to $\pm 800\mu\text{A}$ or below.

6.1.3 Error during Operation

The following error may occur during operation.

Table 6-3 List of error messages during operation

Error message	Content and Cause	Corrective action
OVER TEMPERATURE!	Overheating is detected. Current of amplifier is disconnected and signal is not output. Settings cannot be made. Remote control will also not work. Main reasons are as follows. 1) Malfunction of cooling fan 2) Power supply different from settings 3) Ambient temperature is high	1) Align with the power supply voltage of used by the voltage selector switch on the rear panel. 2) Lower the ambient temperature. Turn off the power supply and wait until the internal temperature reduces to normal range. If this error occurs again after restarting the power supply, repair will be required because of malfunction.

6.1.4 Errors in Remote Control

The following error messages may appear during remote control.

Table 6-4 List of error messages during remote control

Error message	Content and Cause	Content and Cause
REMOTE ERROR	Incorrect syntax in the program code or parameter out of range error detected.	Send the correct program code.

6.2 When the Device Appears to be a Problem

When the device appears to be a problem, check the following table to see if a solution is given. When the problem is not solved or the device cannot be recovered after the corrective action was taken, please contact NF Corporation or one of our representatives.

Table6-5 When the device appears to be a problem

Problem	Possible cause	Correction action
The power does not turn on	The power cord is not connected correctly.	Insert the power cord tightly.
	Settings of the voltage selector switch are incorrect.	Align the voltage selector switch to the voltage of the power supply.
	The power supply out of rated range is used.	Check the voltage of the power socket with tester, etc.
	Fuse is blown.	Replace the fuse. Ensure to use the fuse of pre-decided rating.
Panel operation does not work	The device is in remote state.	When the remote display appears, return to the local state by performing local operation. If there is a local lockout (LLO) in GPIB, you cannot return to local with panel operation. Either operate the controller for go to local (GTL) or disconnect the GPIB cable.
	Keys are deteriorated.	Please ask NF Corporation or one of our representatives for repair.
Settings using external control cannot be made	Different address or USB ID was set with the setting in control program	Set the address so that it matches with the program. Change the program so that it matches with USB ID.
	Same address with another device's	Set the address such that it does not overlap with other device.
Too much noise	Noise is getting mixed	Separate the input cable from the power cord or noise source.
	Source of vibration is near by	Vibration in case or input cable will result in noise. Move away from the source of vibration or take vibration-proof measures.
Signal is small	Connection error of the connection cable	Check that the cable has not disconnected. Moreover, clean the contact.
Output signal is abnormally large	Short circuit of the connection cable	Check that inner and outer conductor of input cable are not short circuit.
	Saturation state	Check after setting I/V range to minimum ($\times 10^4$) and current suppression to OFF.

7. MAINTENANCE

7.1	Introduction	7-2
7.2	Daily Maintenance	7-2
7.3	Storage, Repackaging, and Transport	7-3
7.4	Checking the Version Number	7-3
7.5	Performance Testing	7-4
7.5.1	Current suppression setting accuracy, gain accuracy	7-5
7.5.2	Output offset voltage	7-6
7.5.3	DC bias voltage setting accuracy	7-6
7.6	Calibration	7-7

7.1 Introduction

The following maintenance is essential for using the device under the best condition.

- Operation inspection: Check if the device operates properly.
- Performance testing: Check if the device respects the rated values.
- Adjustment, calibration: If the rated values are not satisfying, NF Corporation will make the necessary adjustment or calibration to restore performance.
- Damage repairs: When performance cannot be restored by the adjustment or calibration, NF Corporation will identify the cause and location of the damage and will execute repairs.

This instruction manual describes how to easily proceed with a performance testing. For more accurate inspections, adjustments, calibration or repairs, contact NF Corporation or one of our representatives.

7.2 Daily Maintenance

Install **CA5350** in a location that fills the installation requirements.

Installation conditions → Refer to “**2.2.2 Installation Conditions**”.

When the case/panel surface needs cleaning, wipe with a soft cloth. To remove persistent contamination, wipe with a soft cloth soaked with neutral detergent and wrung out. Do not use any organic solvents like thinner or benzene, or any chemical cleaning cloth, as they may cause the surface finish to deteriorate, tarnish, or come off.

7.3 Storage, Repackaging, and Transport

● Storage when not using for long term

- Remove the power supply cord from the socket and the body.
- Storage in shelf or rack where there is not dust or other falling objects.
Place a cover when there is a risk that dust may accumulate on the product.
- Maintain the temperature and humidity of the storage location in the following range.

Temperature: -10 to +50 °C

Humidity: 5 to 95 %RH (However, ensure that there is no condensation)

- Do not store in places exposed to direct sunlight, fire or heat source, or place with wide variation in temperature. The product may deform at high temperature, resulting in malfunction.
- Avoiding places having corrosive gases or moisture, dust, motes, and high humidity.
It may corrode the product, resulting in malfunction.

● Repackaging during transportation

Take the following precautions when repackaging for transportation.

- Cover the body with a sheet to protect the surfaces and ensure that fine dust does not get into the body.
- Use a box having appropriate strength and enough dimensional buffer.
- Pack by filling shock-absorbing material such that all six surfaces of the body are protected.
- When using a transportation vendor, instruct the vendor that this product is a precision device.

7.4 Checking the Version Number

The version number of **CA5350** firmware is displayed after power-on.

Version display → Refer to “3.2.1 Display at power ON”.

It is also display the version number on LCD by operating the keys located on the front panel.

Version display → Refer to “4.7.1 Checking the version”.

It is also to read out the version number by remote command “U4”.

About commands → Refer to “5.6 Individual command description”.

Due to product upgrade, version of each product may differ even if they are having the same model name. Operate of the product may differ due to difference in version. If any anomaly is detected, please inform the symptom along with the version number.

7.5 Performance Testing

Performance testing is conducted as part of preventive maintenance to prevent performance degradation of the **CA5350**. Besides, conduct it if needed after acceptance inspection, periodic inspection or repair.

If the result of a performance testing does not meet the specifications, calibration or repair is required. Contact NF Corporation or one of our representatives.

The performance testing should be conducted in the following conditions.

- Power voltage: AC100V / 120V / 220V / 240V \pm 10% (however, 250V or less)
- Ambient temperature: $23\pm 5^{\circ}\text{C}$
- Ambient humidity: 5 to 85%RH, non-condensing
- Warm up: 30 min or more

In performance testing, the measurement instrument and jig requires the following.

- DC voltmeter : Accuracy \pm (0.05% +0.1 mV) at 10V range
- BNC-BNC Cable

Take the following precautions when you conduct a performance testing.

The setting contents for each test item contains the descriptions of items which should be further changed after initializing the factory default setting.

Setting the initialize \Rightarrow “4.4 Saving/Recalling the Settings“

7.5.1 Current suppression setting accuracy, gain accuracy

In this section, easy to measures the total accuracy of the setting accuracy of current suppression and gain accuracy of amplifier. For the exact test, please ask a test to the NF Corporation.

Connection: Connect INVERTING OUTPUT (Front) to DC voltmeter to BNC cable

Setting: FILTER: MANUAL, 1ms

Measurement: Measure the INVERTING OUTPUT voltage with the DC voltmeter.

Evaluation: If the values indicated on DC voltmeter are within the specification range in table, it is normal.

Current suppression		Amplifier gain		Values indicated on DC voltmeter	Specification
Range	Setting	Gain (V/A)	Output amplifier gain		
8nA	+0.900nA	10G	×1	+8.490V ~ +9.510V	±(5.33%+30mV)
8nA	+0.000nA	10G	×1	-0.150V ~ +0.150V	±150mV
8nA	+8.000nA	1G	×1	+7.648V ~ +8.352V	±(4.15%+20mV)
8nA	+0.000nA	1G	×1	-0.032V ~ +0.032V	±32mV
80nA	+80.00nA	100M	×1	+7.808V ~ +8.192V	±(2.15%+20mV)
80nA	+0.00nA	100M	×1	-0.032V ~ +0.032V	±32mV
800nA	+800.0nA	10M	×1	+7.880V ~ +8.120V	±(1.25%+20mV)
800nA	+0.0nA	10M	×1	-0.032V ~ +0.032V	±32mV
8μA	+8.000μA	1M	×1	+7.900V ~ +8.100V	±(1.0%+20mV)
8μA	+0.000μA	1M	×1	-0.032V ~ +0.032V	±32mV
80μA	+80.00μA	100k	×1	+7.900V ~ +8.100V	±(1.0%+20mV)
80μA	+0.00μA	100k	×1	-0.032V ~ +0.032V	±32mV
800μA	+800.0μA	10k	×1	+7.900V ~ +8.100V	±(1.0%+20mV)
800μA	+0.0μA	10k	×1	-0.032V ~ +0.032V	±32mV
80μA	+80.00μA	10k	×10	+7.180V ~ +8.820V	±(7.75%+200mV)

7.5.2 Output offset voltage

Connection: Connect INVERTING OUTPUT (Front) to DC voltmeter to BNC cable

Setting: FILTER ON, MANUAL

Measurement: Measure the INVERTING OUTPUT voltage with the DC voltmeter.

Evaluation: If the values indicated on DC voltmeter are within the specification range in table, it is normal.

Filter setting	Values indicated on DC voltmeter	Specification
30 μ s	-20mV ~ +20mV	\pm 20mV
3ms		
10ms		

7.5.3 DC bias voltage setting accuracy

Connection: Connect INVERTING BIAS OUTPUT (Front) to DC voltmeter to BNC cable

Setting: BIAS : ON

Measurement: Measure the INVERTING BIAS OUTPUT voltage with the DC voltmeter.

Evaluation: If the values indicated on DC voltmeter are within the specification range in table, it is normal.

DC bias voltage setting	Values indicated on DC voltmeter	Specification
-8.000V	+7.900V ~ +8.100V	\pm (1%+20mV)
0.000V	-20mV ~ +20mV	\pm 20mV
+8.000V	-8.100V ~ -7.900V	\pm (1%+20mV)

Note: Voltage of reverse polarity of the setting will appear.

7.6 Calibration

If the performance test does not satisfy the specification, NF Corporation will make the necessary adjustment or calibration to recover the performance.

If calibration is necessary, contact NF Corporation or one of our representatives.

You will be liable for the costs of adjustment and calibration outside the warranty period.

8. SPECIFICATIONS

8.1	Specifications	8-2
8.1.1	Input section.....	8-2
8.1.2	Current suppression section	8-3
8.1.3	Amplifier section.....	8-3
8.1.4	Output section	8-4
8.1.5	DC bias voltage output section	8-4
8.1.6	General information.....	8-5
8.2	External Dimensions	8-7

Supplementary value: This value implies supplementary data of the product and it does not guarantee the product performance.

8.1 Specifications

8.1.1 Input section

- Input form DC coupled unbalanced input
- Input connector Insulating type BNC receptacle
Either front panel/rear panel input connector can be used
- Non-destructive maximum input current
 $\pm 30\text{mA}$
- Rated maximum input current

Gain setting (V/A)	Output amplifier gain setting	
	$\times 1$	$\times 10$
10G	$\pm 1\text{nA}$	$\pm 100\text{pA}$
1G	$\pm 10\text{nA}$	$\pm 1\text{nA}$
100M	$\pm 100\text{nA}$	$\pm 10\text{nA}$
10M	$\pm 1\mu\text{A}$	$\pm 100\text{nA}$
1M	$\pm 10\mu\text{A}$	$\pm 1\mu\text{A}$
100k	$\pm 100\mu\text{A}$	$\pm 10\mu\text{A}$
10k	$\pm 1\text{mA}$	$\pm 100\mu\text{A}$

- Input impedance (supplementary value)

Gain setting (V/A)	Input impedance	Remarks
10G	$30\text{k}\Omega$	at 100Hz
1G	$10\text{k}\Omega$	at 1kHz
100M	$3\text{k}\Omega$	
10M	$1\text{k}\Omega$	
1M	400Ω	
100k	300Ω	
10k	10Ω	

- Recommended source resistance (supplementary value)

Gain setting (V/A)	Recommended source resistance
10G	$1\text{G}\Omega$ or more
1G	$100\text{M}\Omega$ or more
100M	$10\text{M}\Omega$ or more
10M	$1\text{M}\Omega$ or more
1M	$100\text{k}\Omega$ or more
100k	$10\text{k}\Omega$ or more
10k	$1\text{k}\Omega$ or more

- Equivalent input current noise density (supplementary value)

Gain setting (V/A)	Equivalent input current noise density	Remarks
10G	$2.5\text{fA}/\sqrt{\text{Hz}}$	at 55Hz
1G	$6\text{fA}/\sqrt{\text{Hz}}$	at 200Hz
100M	$15\text{fA}/\sqrt{\text{Hz}}$	
10M	$45\text{fA}/\sqrt{\text{Hz}}$	at 1kHz
1M	$150\text{fA}/\sqrt{\text{Hz}}$	
100k	$750\text{fA}/\sqrt{\text{Hz}}$	
10k	$6\text{pA}/\sqrt{\text{Hz}}$	

Conditions: Input open, Front input, Filter $300\mu\text{s}$ (10G V/A) or $30\mu\text{s}$ (1G V/A ~ 10k V/A), no source capacitance

8.1.2 Current suppression section

Built-in current source for cancelling DC current of the source of signal, and it is connected to the input terminal of this instrument.

- Range 6 ranges (8nA, 80nA, 800nA, 8μA, 80μA, 800μA) or OFF
- Setting range
 - 8nA range -8.000nA ~ +8.000nA, resolution 1pA
 - 80nA range -80.00nA ~ +80.00nA, resolution 10pA
 - 800nA range -800.0nA ~ +800.0nA, resolution 100pA
 - 8μA range -8.000μA ~ +8.000μA, resolution 1nA
 - 80μA range -80.00μA ~ +80.00μA, resolution 10nA
 - 800μA range -800.0μA ~ +800.0μA, resolution 100nA
- Setting accuracy (supplementary value)
 - 8nA range $\pm(|3.0\% \text{ of setting} | + 0.15\% \text{ of range})$
 - 80nA range $\pm(|1.5\% \text{ of setting} | + 0.15\% \text{ of range})$
 - 800nA range $\pm(|0.8\% \text{ of setting} | + 0.15\% \text{ of range})$
 - 8μA range -800μA range $\pm(|0.6\% \text{ of setting} | + 0.15\% \text{ of range})$
- Auto suppression Function for automatically selecting and setting the current value and current suppression range required for cancelling the input current when auto suppression is ON.

8.1.3 Amplifier section

- Gain accuracy at DC

Gain setting (V/A)	Output amplifier gain settings	
	×1	×10
10G	$1 \times 10^{10} \pm 1.0\%$	$1 \times 10^{11} \pm 1.0\%$
1G	$1 \times 10^9 \pm 1.0\%$	$1 \times 10^{10} \pm 1.0\%$
100M	$1 \times 10^8 \pm 0.5\%$	$1 \times 10^9 \pm 0.5\%$
10M	$1 \times 10^7 \pm 0.3\%$	$1 \times 10^8 \pm 0.3\%$
1M	$1 \times 10^6 \pm 0.25\%$	$1 \times 10^7 \pm 0.25\%$
100k	$1 \times 10^5 \pm 0.25\%$	$1 \times 10^6 \pm 0.25\%$
10k	$1 \times 10^4 \pm 0.25\%$	$1 \times 10^5 \pm 0.25\%$

- Frequency characteristics Conditions: Filter OFF, Output amplifier gain ×1, no source capacitance

Gain setting (V/A)	Within +0.5dB/-3dB	Response speed (supplementary value)	Remarks
10G	DC ~ 14kHz	25μs	Reference frequency: 1Hz Reference frequency: 10Hz
1G	DC ~ 70kHz	5μs	
100M	DC ~ 175kHz	2μs	
10M	DC ~ 350kHz	1μs	
1M	DC ~ 500kHz	0.7μs	
100k			
10k			

Response speed is the rise time (10%–90%) of square output response waveform.

● Output amplifier gain	×1 or ×10	Gain after current-voltage conversion
● Filter		
Setting range		Response speed (rise time) 1μs ~ 300ms, 1-3 sequence or OFF
Setting accuracy		Less than ±20% of the setting time (10%-90% rise time) (supplementary value)
Filter characteristics		Low-pass filter (LPF), phase-linear type
Attenuation slope		12dB/oct
● I/O polarity		Inverted (Once current starts flowing in the input connector, output will have minus potential)

8.1.4 Output section

● Output form		DC coupled unbalanced output
● Output connector		Front and rear panel, insulated type BNC receptacle Same signal is output from the front and the rear connectors.
● Maximum output voltage		±10V (when no load)
● Maximum output current		±10mA Total current of front and rear connectors
● Output impedance		50Ω (supplementary value)
● Output offset voltage		Less than ±30mV When amplifier gain is 10G(V/A) Less than ±20mV When amplifier gain is 10k ~ 1G(V/A) (Conditions: Input open, Current suppression OFF, and Output amplifier gain ×1)

8.1.5 DC voltage bias output section

● Output form		DC coupled unbalanced output
● Output connector		Front and rear panel, insulated type BNC receptacle Same signal is output from the front and the rear connectors.
● Setting range		-8.000V ~ +8.000V, resolution 0.001V
● Setting accuracy		±(1.0% of setting + 20mV) (when no load)
● Maximum output current		±2mA Total current of front and rear connectors
● Output impedance		50Ω (supplementary value)
		DC bias will output voltage with inverted polarity. Example: When +1.000V is set, -1.000V will be output in the DC bias voltage output BNC connector.

8.1.6 General information

- Display device 20 characters × 2 lines Black and white LCD
Backlight brightness can be set on 3 stages including OFF
- Memory for saving the setting 10 sets (including 1 set reserved for factory default settings)
- I/O grounding Signal grounding of Input (CURRENT INPUT), Output (INVERTING OUTPUT), and bias output (INVERTING BIAS OUTPUT) are insulated from the enclosure. Their signal grounding is common.
Maximum withstanding voltage between signal grounding and enclosure is 42Vpk (DC+ACpeak).
- Input over detection Excessive signal is detected and displayed on LCD.
Over will detect the signal (input over) after current-voltage conversion and signal (output over) of output connector separately, and it will also display them separately.
- External control
 - GPIB IEEE488.1
 - USB USB1.1 full speed, device class CDC
- Power supply
 - Voltage AC100V / 120V / 220V / 240V ±10%
However, 250V or less
 - Frequency 50Hz/60Hz ±2Hz
 - Power consumption 40VA or less
 - Overvoltage category II
- Cooling of device Forced cooling, rear panel discharge type
- Setting posture Horizontal (10° or less)

● Environmental conditions

Operation	Temperature : 0 to +40°C Humidity : 5 to 85%RH Absolute humidity 1 to 25g/m ³ , non-condensing Altitude : 2000m or less
Performance guarantee	Temperature : 23±5°C Humidity : 5 to 85%RH Absolute humidity 1 to 25g/m ³ , non-condensing Altitude : 2000m or less
Storage	Temperature : -10 to +50°C Humidity : 5 to 95%RH Absolute humidity 1 to 29g/m ³ , non-condensing

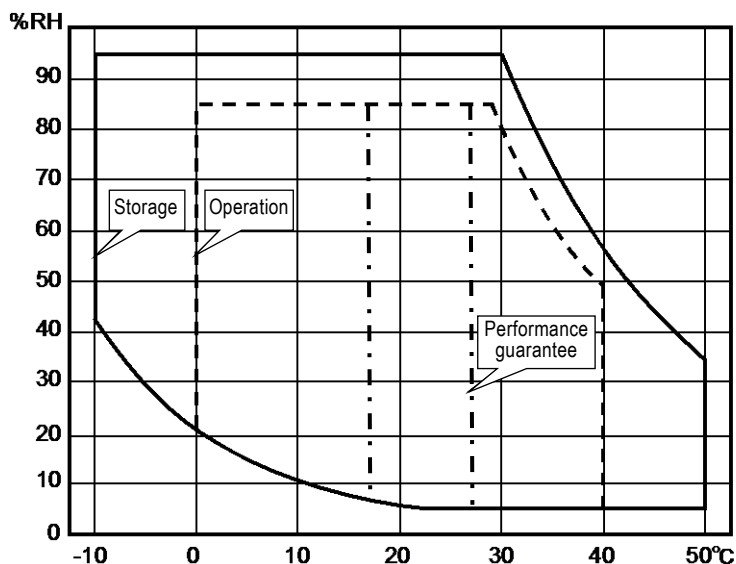

Pollution Degree	2 (indoor use)
● Warn-up time	30 minutes
● Safety regulation	EN61010-1 EN61010-2-030
● EMC	EN61326-1 (Group 1, Class A) EN61326-2-1 EN61000-3-2 EN61000-3-3
● RoHS directive	Directive 2011/65/EU
● External dimensions	Approx. 216 (W) × 88 (H) × 400 (D) mm, not including protuberances
● Weight	Approx. 5.0kg (not including accessories)

8.2 External Dimensions

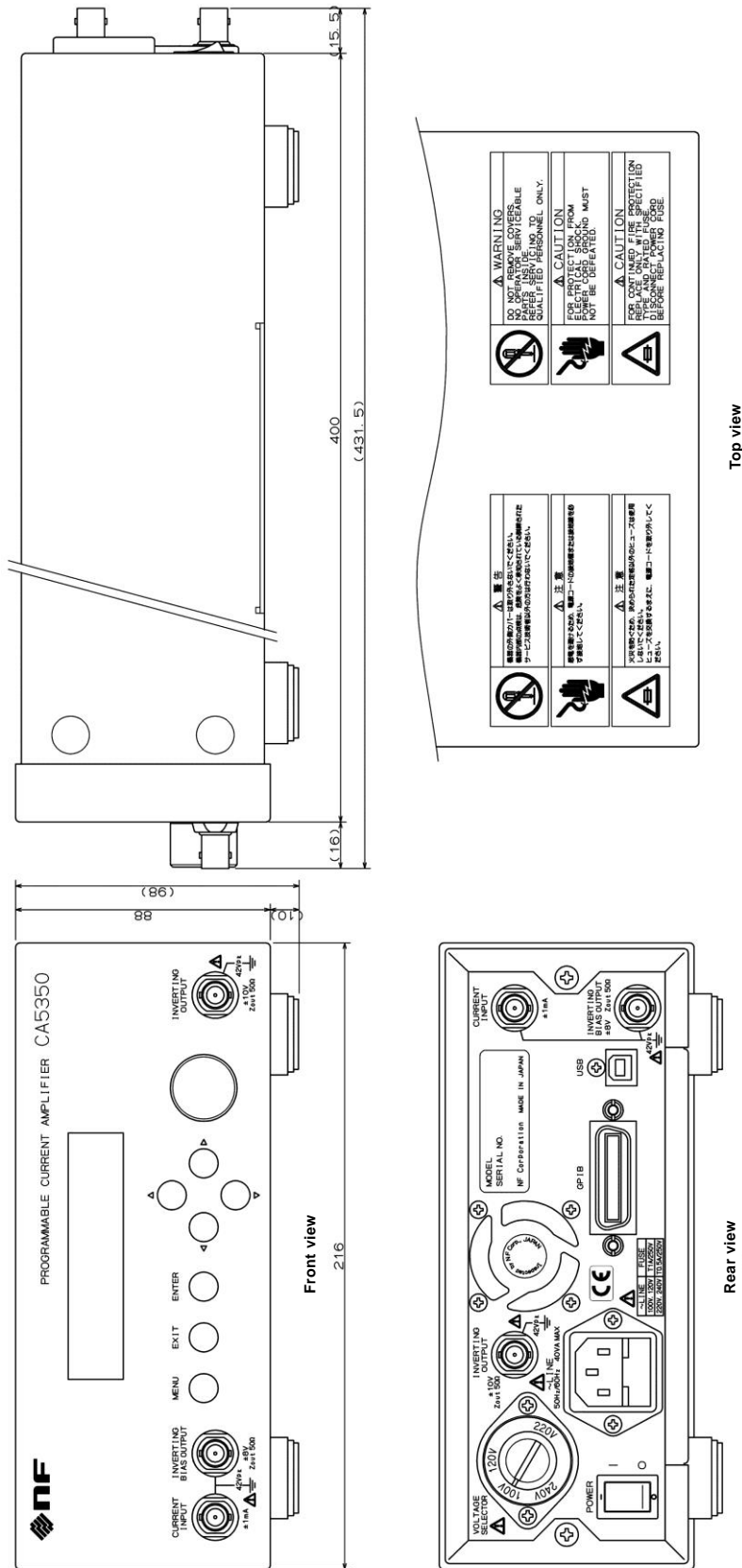

Surface treatment : Clear hairline silver
 Front panel : Matt gray
 Rear panel : Matt gray
 Cover : Light metallic gray

Figure 8-1 CA5350 External Dimensions

——— WARRANTY ———

NF Corporation certifies that the **CA5350 PROGRAMMABLE CURRENT AMPLIFIER** was thoroughly tested and inspected when it was shipped from our factory.

If any failures attributable to defects in material and workmanship or accidents during transportation are found, please get in touch with NF Corporation or one of our representatives.

For the product purchased from NF Corporation or one of our representatives, any failures found to be caused by NF Corporation's responsibility such as parts failures that occurred under normal operating conditions or defects in material and workmanship shall be covered by the warranty for one year after the date of delivery.

NF Corporation will repair such defective product free of charge, if the purchaser contacts NF Corporation or one of our representatives within the warranty period.

This warranty is valid only in Japan. When the product is to be used outside Japan, please consult NF Corporation or one of our representatives.

Repair of defective product that occurred by either of the following causes shall be charged even within the warranty period.

- Failure due to the handling or storage that violates the operating methods or precautions given in the instruction manual
- Failure or damage caused by a fall or shock during transportation or relocation performed by the purchaser
- Modification made to the product by the purchaser
- Failure by external abnormal voltage or influence of external device connected to the product
- Failure or damage caused by fire, earthquake, flood, thunder, rebellion, war, and force majeure including other act of providence.
- Replenishment of consumable parts such as batteries

——— REPAIR ——

When a failure occurred and the product was found to be defective or you have any uncertainty, please get in touch with NF Corporation or one of our representatives.

In such a case, let us know the model name (or product name), serial number (SERIAL No. given on the nameplate) and symptom and operating conditions as detail as possible.

Though we will make efforts to reduce the repair period, when five or more years have passed since you purchased the product, it may take time due to, for instance, the out of stock of repair parts.

Also, if the production of repair parts is discontinued, the product is extremely damaged or the product is modified, we may decline the repair.

NOTES

- Reproduction of the instruction manual, part or whole, is forbidden without prior written permission.
- The contents of the instruction manual are subject to change without notice.
- Information provided in the instruction manual is intended to be accurate and reliable. However, we assume no responsibility for any damage regarding the contents of the instruction manual.

If you have any uncertainty or you found an error or omission, please contact NF Corporation or one of our representatives from which you purchased the product.

CA5350 Instruction Manual

NF Corporation

6-3-20 Tsunashima Higashi, Kohoku-ku, Yokohama 223-8508, JAPAN

Phone: +81-45-545-8128

<http://www.nfcorp.co.jp/>

© Copyright 2022, **NF Corporation**

